

(19) World Intellectual Property  
Organization  
International Bureau



(43) International Publication Date  
3 February 2005 (03.02.2005)

PCT

(10) International Publication Number  
**WO 2005/010568 A2**

- (51) International Patent Classification<sup>7</sup>: **G02B**
- (21) International Application Number: PCT/US2004/023318
- (22) International Filing Date: 20 July 2004 (20.07.2004)
- (25) Filing Language: English
- (26) Publication Language: English
- (30) Priority Data: 60/488,851 21 July 2003 (21.07.2003) US
- (71) Applicant (for all designated States except US): **THE TITAN CORPORATION** [US/US]; 3033 Science Park Road, San Diego, CA 92121-1002 (US).
- (72) Inventor; and
- (75) Inventor/Applicant (for US only): **BRYARS, John, Denny** [US/US]; 29852 Platanus Drive, Escondido, CA 92026 (US).
- (74) Agent: **MEADOR, Terrance, A.**; Incaplaw, Suite K, 1050 Rosecrans Street, San Diego, CA 92106 (US).
- (81) Designated States (unless otherwise indicated, for every kind of national protection available): AE, AG, AL, AM, AT, AU, AZ, BA, BB, BG, BR, BW, BY, BZ, CA, CH, CN, CO, CR, CU, CZ, DE, DK, DM, DZ, EC, EE, EG, ES, FI, GB, GD, GE, GH, GM, HR, HU, ID, IL, IN, IS, JP, KE, KG, KP, KR, KZ, LC, LK, LR, LS, LT, LU, LV, MA, MD, MG, MK, MN, MW, MX, MZ, NA, NI, NO, NZ, OM, PG, PH, PL, PT, RO, RU, SC, SD, SE, SG, SK, SL, SY, TJ, TM, TN, TR, TT, TZ, UA, UG, US, UZ, VC, VN, YU, ZA, ZM, ZW.
- (84) Designated States (unless otherwise indicated, for every kind of regional protection available): ARIPO (BW, GH, GM, KE, LS, MW, MZ, NA, SD, SL, SZ, TZ, UG, ZM, ZW), Eurasian (AM, AZ, BY, KG, KZ, MD, RU, TJ, TM), European (AT, BE, BG, CH, CY, CZ, DE, DK, EE, ES, FI, FR, GB, GR, HU, IE, IT, LU, MC, NL, PL, PT, RO, SE, SI,

[Continued on next page]

(54) Title: OPTICAL VITAL SIGNS MONITOR

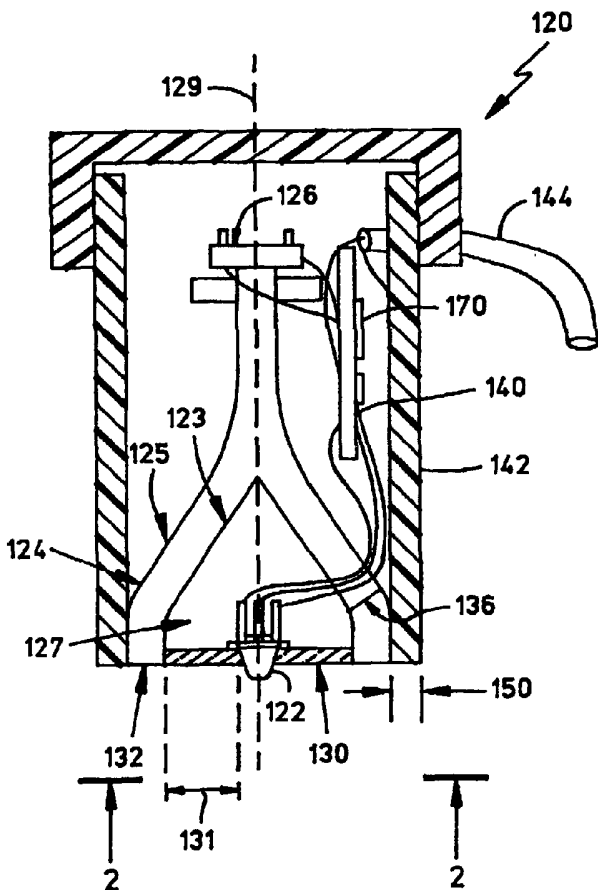

(57) Abstract: The present invention provides an optical vital signs apparatus and method for optically measuring vital signs of a subject. The apparatus includes a light source, a light pipe having a collecting surface and a terminal end. The light source being positioned proximate the collecting surface and a light detector positioned proximate the terminal.

WO 2005/010568 A2



SK, TR), OAPI (BF, BJ, CF, CG, CI, CM, GA, GN, GQ, GW, ML, MR, NE, SN, TD, TG).

**Declarations under Rule 4.17:**

- *as to applicant's entitlement to apply for and be granted a patent (Rule 4.17(ii)) for the following designations AE, AG, AL, AM, AT, AU, AZ, BA, BB, BG, BR, BW, BY, BZ, CA, CH, CN, CO, CR, CU, CZ, DE, DK, DM, DZ, EC, EE, EG, ES, FI, GB, GD, GE, GH, GM, HR, HU, ID, IL, IN, IS, JP, KE, KG, KP, KR, KZ, LC, LK, LR, LS, LT, LU, LV, MA, MD, MG, MK, MN, MW, MX, MZ, NA, NI, NO, NZ, OM, PG, PH, PL, PT, RO, RU, SC, SD, SE, SG, SK, SL, SY, TJ, TM, TN, TR, TT, TZ, UA, UG, UZ, VC, VN, YU, ZA, ZM, ZW, ARIPO patent (BW, GH, GM, KE, LS, MW, MZ, NA, SD, SL, SZ, TZ, UG, ZM, ZW), Eurasian patent (AM, AZ, BY, KG, KZ, MD, RU, TJ, TM), European patent (AT, BE, BG, CH, CY, CZ, DE, DK, EE, ES, FI, FR, GB, GR, HU, IE, IT, LU, MC, NL, PL, PT, RO, SE, SI, SK, TR), OAPI patent (BF, BJ, CF, CG, CI, CM, GA, GN, GQ, GW, ML, MR, NE, SN, TD, TG)*
- *as to the applicant's entitlement to claim the priority of the earlier application (Rule 4.17(iii)) for the following designations AE, AG, AL, AM, AT, AU, AZ, BA, BB, BG, BR, BW,*

*BY, BZ, CA, CH, CN, CO, CR, CU, CZ, DE, DK, DM, DZ, EC, EE, EG, ES, FI, GB, GD, GE, GH, GM, HR, HU, ID, IL, IN, IS, JP, KE, KG, KP, KR, KZ, LC, LK, LR, LS, LT, LU, LV, MA, MD, MG, MK, MN, MW, MX, MZ, NA, NI, NO, NZ, OM, PG, PH, PL, PT, RO, RU, SC, SD, SE, SG, SK, SL, SY, TJ, TM, TN, TR, TT, TZ, UA, UG, UZ, VC, VN, YU, ZA, ZM, ZW, ARIPO patent (BW, GH, GM, KE, LS, MW, MZ, NA, SD, SL, SZ, TZ, UG, ZM, ZW), Eurasian patent (AM, AZ, BY, KG, KZ, MD, RU, TJ, TM), European patent (AT, BE, BG, CH, CY, CZ, DE, DK, EE, ES, FI, FR, GB, GR, HU, IE, IT, LU, MC, NL, PL, PT, RO, SE, SI, SK, TR), OAPI patent (BF, BJ, CF, CG, CI, CM, GA, GN, GQ, GW, ML, MR, NE, SN, TD, TG)*

- *of inventorship (Rule 4.17(iv)) for US only*

**Published:**

- *without international search report and to be republished upon receipt of that report*

*For two-letter codes and other abbreviations, refer to the "Guidance Notes on Codes and Abbreviations" appearing at the beginning of each regular issue of the PCT Gazette.*

## **OPTICAL VITAL SIGNS MONITOR**

Priority is claimed to US Provisional Patent Application 60/488,851, filed July 21, 2003 for "Optical Vital Signs Monitor".

The invention described herein relates generally to optical vital signs monitoring, and more specifically to the measure and monitoring of vital signs through optical reflectance techniques.

### **SUMMARY OF THE INVENTION**

The invention advantageously addresses the needs and drawbacks of previous vital sign monitors as well as other needs by providing an apparatus and method for measuring and monitoring vital signs of patients through optical reflectance. In one embodiment, the invention provides an apparatus optically measuring vital signs of a subject. The apparatus includes a light source, an opaque region positioned about the light source, a light guide positioned along at least a portion of a perimeter of the opaque region, wherein the light guide includes a collecting surface, and a light detector positioned proximate a terminal end of the light guide, wherein the light guide is configured to direct light impinging on the collecting surface to impinge on the light detector.

In another embodiment, the invention provides a method for optical vital sign measuring. The method includes the steps of collecting reflected light; propagating the reflected light to a detector; detecting the amount of reflected light; and determining an oxygen blood saturation level.

In still another embodiment, the invention provides an apparatus for optically measuring vital signs that includes means for collecting reflected light; means for propagating the reflected light; means detecting the amount of reflected light propagated; and means for determining blood oxygen saturation level and heart rate.

A better understanding of the features and advantages of the present invention will be obtained by reference to the following detailed description of the

invention and accompanying drawings that set forth an illustrative embodiment in which the principles of the invention are utilized.

### **BRIEF DESCRIPTION OF THE DRAWINGS**

The above and other aspects, features and advantages of the present invention will be more apparent from the following more particular description thereof, presented in conjunction with the following drawings wherein:

FIG. 1 shows a simplified cross-sectional view of a vital sign monitoring apparatus according to one embodiment of the invention;

FIG. 2 shows a lower view of the apparatus depicted in FIG. 1, showing a light shield or guard and the light collecting surface of the light pipe;

FIG. 3 shows a simplified schematic diagram of a photo diode preamplifier;

FIG. 4 shows a cross-sectional view of the vital sign monitoring apparatus depicted in FIG. 1 in operation on a patient or subject;

FIG. 5 shows a cross-sectional view of an optical vital sign monitoring apparatus according to another embodiment of the invention;

FIG. 6 shows a side view of the apparatus shown in FIG. 5;

FIG. 7 shows an elevated plane view of the apparatus shown in FIG. 5;

FIG. 8 shows a cross-sectional view of photo diode placement for the apparatus shown in FIGS. 6 and 7;

FIG. 9 shows a planer view of the contact portion of an alternate embodiment vital sign monitoring apparatus that contacts the skin of a subject being measured and/or monitored;

FIG. 10 shows a cross-sectional view of the vital sign monitoring apparatus depicted in FIG. 9;

FIG. 11 shows a side view of a vital sign measurement apparatus according to another embodiment of the invention;

FIG. 12 shows a planer view of a contact portion of the vital sign measuring apparatus depicted in FIG. 11;

FIG. 13 shows a simplified planer view of a contact surface of a vital sign measuring sensor according to another embodiment of the invention;

FIG. 14 shows a cross-sectional view a light propagation guide or lens of the vital sign sensor depicted in FIG. 13;

FIG. 15 shows a cross-sectional view of the light propagating lens depicted in FIGS. 13 and 14;

FIG. 16 shows a block diagram of a functional signal flow for a data acquisition system according to one embodiment of the present invention;

FIG. 17 shows a sample of a timing diagram for the operation of the vital sign monitor or sensor and data acquisition system depicted in FIG. 16;

FIG. 18 shows a small sample of measured data taken by the apparatus and/or system depicted in any one of FIGS. 1, 6, 10, 11 and 13; and

FIG. 19 shows a blanket according to one embodiment of the present invention incorporating a vital sign measuring apparatus as used on an infant patient.

Corresponding reference characters indicate corresponding components throughout the several views of the drawings.

## **DETAILED DESCRIPTION OF THE INVENTION**

The following description is not to be taken in a limiting sense, but is made merely for the purpose of describing the general principles of the invention. The scope of the invention should be determined with reference to the claims.

The present invention discloses apparatuses and methods for measuring and/or monitoring patient vital signs utilizing optical signal reflectance. Examples of some of the vital signs that can be measured by optical signal reflectance include blood oxygen saturation (SpO<sub>2</sub>) and heart rate. Measurement is done by illuminating the surface and subcutaneous area of the skin, the optical signal is then measured as it is reflected and modulated by the tissue, blood and/or arterial blood flow. In some embodiments, the present method and apparatus additionally measures and/or monitors the subject or patient's body temperature at the sensor site.

The present invention provides a sensor that can make these measurements when placed on the subject being monitored, for example on the chest, back, arm, leg, hand, head or substantially any other part of the patient's or subject's body. These vital signs can be particularly important in determining the current health of a subject, and can be critical parameters in diagnosis, for example with premature babies and babies with other deficiencies or physiological abnormalities. By providing an immediate indication of these parameters, attending medical personnel are able to accurately determine the health status of the patient or subject. In the case of neonatal births determination of these vital signs becomes even more important, particularly in instances where immediate resuscitation is required to normalize the infant's life sustaining functions. The present invention can be employed as a spot check device or provide continuous monitoring of a subject.

The present invention has numerous applications, including applications in hospital delivery rooms, in emergency medicine, intensive care units, home health monitoring of infants and the elderly and several other applications.

In one embodiment, the apparatus for measuring vital signs includes a sensing device that employs a lens design that provides a highly efficient collector of the optical signal back scattered from the patient. The optical signal can be substantially any optical signal, and typically includes a plurality of optical signals at different wavelengths. For example, the apparatus can generate a first red optical signal and a second near infrared optical signal.

FIG. 1 depicts a simplified cross-sectional schematic diagram of a vital sign monitoring apparatus 120 according to one embodiment of the present invention. The apparatus includes one or more light emitting devices or sources 122. The light emitting device is a bi-color light emitting diode (LED) that is activated to generate pulsed illumination at two predefined spectra. For example, the LED 122 can be configured to generate pulsed illumination at a first spectra of about 660 nm (red spectra) and at a second spectra of about 940 nm (near infrared spectra). However, illumination sources of virtually any spectral output can be used to make noninvasive optical measurements on patients or subjects. Advantageously, the LED is able to project illumination directly into the tissue as shown in FIG. 4. The shape of the LED lens must enable the LED to project light through the skin at the point of contact.

The apparatus 120 additionally includes a light guide or light pipe lens 124 with a light detecting or collecting surface 132. The light pipe lens 124 (and light collecting surface 132) is circumferentially positioned about the light source 122. The light pipe lens 124 collects reflected light emitted by the light source and reflected by the tissue 162 (see FIG. 4) of the patient or subject being measured and/or monitored. The light pipe lens 124 directs the collected light through the pipe to a terminal end of the light pipe to a light or optical signal detector 126. Typically, the optical detector 126, such as one or more photo diodes or phototransistors, is mounted at an apex of the light pipe lens 124. The light pipe lens 124 can be constructed of substantially any material capable of directing light including poly carbonate, water clear poly carbonate, plastics, glass, and substantially any other material or combination of materials capable of directing light emitted from the one or more light sources 122.

The light pipe extends away from the collecting surface 132 in a generally cylindrical shape where the collected light is directed through the light pipe lens 124 between an inner surface 123 and an outer surface 125. The light pipe lens 124 extends away from the collecting surface 132 and tapers in towards a central axis 129 forming a generally cone shape or tepee shape. However, it will be apparent to one skilled in the art that the tapering of the light pipe is not limited to a central axis but can be to substantially any axis. The inner surface 123 additionally tapers forming a generally interior cone 127. The interior cone 127 can be filled or partially filled with

a resin, plastic or other material, or alternatively, can be filled or partially filled with gases. The material filling the interior cone 127 can be configured to have reflective characteristics to aid in propagating light along the light pipe lens 124. Additionally, the filler material should block any back-scattered illumination from the LEDs from shining on the inner surface of the light pipe lens 124. The inner surface 123 may be coated with a reflective material or a reflective material may be fixed to the inner surface to aid in the propagation of light to the detector. The outer surface 125 is similarly tapered such that the collected light is directed through the light pipe to impinge on the detector 126. The outer surface 125 may be coated with a reflective material or a reflective material may be fixed to the outer surface to aid in the propagation of light to the detector.

The light pipe 124 is positioned about the light source 122 at a predefined distance 131 from the light source. The apparatus 120 includes a light shield or light guard 130. The light pipe 124 is positioned about the exterior perimeter of the light shield 130. FIG. 2 depicts a lower view of the apparatus 120, showing the light shield 130 and the light collecting surface 132 of the light pipe 124. Typically, the light source 122 is centrally positioned, with the light shield 130 positioned about the light source. The light shield 130 may be formed of an opaque disk with the light source 122 mounted near the center. The light shield 130 is designed to limit the amount of direct illumination from the light source 122 that reaches the collecting surface 132 of the light pipe lens 124 in an attempt to assure that light reaching the detecting surface 132 is back scattered light and has propagated through a sufficient amount of tissue to have some level of modulation from the pulsing capillary and arterial blood just below the surface of the patient's skin.

The light shield 130 is configured with a predefined radius and is dimensioned to minimize direct illumination and can be dependent upon the intensity of the light source 122. With a light source 122 generating an optical signal at a predefined intensity, the opaque light shield 130 can have a radius of between 1mm and 20mm, preferably between 3mm and 10mm and more preferably between 5mm and 7mm for the optimal detection of pulsing blood from arterial sources. The light shield 130 may be constructed of substantially any material capable of limiting the

direct illumination, such as, metal, opaque plastic or any other material or combination of materials capable of limiting direct illumination of the light collecting surface 132.

Electrical connections to power the light source 122 may be made through a small channel or hole 136 formed or drilled in the light pipe lens 124. The light source 122 and detector 126 can be coupled with controllers, drivers, amplifiers and other similar circuitry 140. The apparatus may include some or all of the control and/or amplifier circuitry within a housing or casing 142. Alternatively, some or all of the control and/or amplifier circuitry can be external to the housing 142. For example, the light source 122 and detector 126 can couple through wiring 144 to a processor, microprocessor and/or computer where control signals are generated and the detected optical signals are processed and/or analyzed.

FIG. 3 depicts a simplified schematic diagram of a preamplifier 170 according to one embodiment of the present invention. The preamplifier 170 provides signal gain for the detected optical signal from the detector 126. In one embodiment, the preamplifier 170 is positioned within the housing 142. The detector 126, for example a photo diode, detects the reflected and modulated optical signals emitted by the one or more light sources 122 (e.g., LEDs). The detected light is compared by a differential amplifier 172 with a reference voltage, such as ground or a relatively constant measured light (e.g., measured ambient light). The amplifier 172 amplifies the difference between the reference and the measured light according to the gain defined through the amplifier 172 and a feedback path 174. In the embodiment shown in FIG. 3, the feedback path includes a resistive capacitive network. The preamplifier 170 can be configured through substantially any amplifier configuration. In one embodiment, the amplifier is a transimpedance amplifier that converts the detected current proportional to the detected light to a voltage, for example, amplifying a 1  $\mu$ A of photo diode signal current to a 1 V output of the preamplifier 170.

Referring back to FIG. 1, the housing 142 can be constructed of substantially any material capable of maintaining positioning and protecting the

components of the apparatus 120 including, but not limited to metal, plastics and other similar materials or combinations of materials. In one embodiment, the housing 142 reduces the emission of and/or protects the apparatus 120 from electromagnetic interference (EMI) and ambient light back illuminating the detector. Further, the housing 142 can have a thickness 150 near the lens surface 132 of a sufficient width to limit the amount of ambient light collected and propagated through the light pipe to the detector 126.

FIG. 4 shows a cross-sectional view of the vital sign monitoring apparatus 120 in operation on a patient or subject. Typically, the apparatus 120 is placed on the surface of the skin 162 of the subject. Pulsed illumination 164 is projected into the surface of the skin 162 and scattered through the tissue about the light source 122. The emitted light 164 is propagated through the tissue and modulated by pulsing variations in subcutaneous blood, blood vessels, capillaries and other anatomy of the subject being measured and/or monitored. The reflected light 166 is collected and propagated through the light pipe 124 and detected by the optical detector 126. The detector generates a signal proportional to the amount of detected light. The signal is amplified by an amplifier 170 and forwarded over communication link 144 to external processor and display devices.

FIGS. 5-7 depict a cross-sectional view, a side plane view and an elevated plane view, respectively, of an optical vital sign monitoring apparatus 220 according to another embodiment of the invention. The apparatus 220 includes a plurality of relatively low profile optical wave guides or lenses 222 configured as quadrants. In the embodiment shown, the apparatus 220 is configured with four lenses 222 extending out radially from generally a central point or axis 224. However, it will be apparent to one skilled in the art that any number of lenses can be utilized without departing from the inventive aspects of the invention.

Each lens 222 includes a light collecting surface 226 that is positioned, when in use, proximate or against the subject's skin. Each lens 222 additionally tapers perpendicular to the central axis 224 at a terminal end of the lens proximate the central axis 224. In one embodiment, the lenses are tapered to a point 240. The

lenses 222 can be constructed of substantially any material capable of propagating the spectrum of light transmitted into the subject, such as plastic, glass, water clear polycarbonate plastic, and substantially any other material or combination of materials capable of propagating the reflected optical signals.

One or more light sources 232 protrudes proximate the central axis 224 away from the lenses 222, such that in operation, the one or more light sources 232 are in close proximity or in contact with the subject's skin (not shown). The one or more light sources 232 generate light at a plurality of spectrum to penetrate the subject's skin to be reflected by blood, blood vessels and other anatomy of the subject.

An opaque disk 234 separates the light source 232 from the lenses 222 to limit, and preferably prevent direct illumination of the lenses 222. The opaque disk 234 is configured with a radius that is of sufficient width to limit, and preferably prevent, direct illumination of the lenses 222. In one embodiment, with an optical source emitting a light at a first intensity, the radius of the opaque disk 234 is at least 2mm, preferably at least 4mm and more preferably at least 5mm.

The apparatus 220 additionally includes a reflective pyramid 240. The pyramid 240 is axially aligned with the central axis 224 and extends away from the light source 232 such that the peak of the pyramid 240 extends between the tapered points 240 of the lenses 222. Typically, the pyramid includes a number of sides equal to the number of lenses incorporated within the apparatus 220. For example, if the apparatus includes four lenses, the reflective pyramid 240 can have four sides. In operation, the lenses 222 collect reflected light through the collecting surface 226. The collected light is reflected along the lenses 222 towards the tapered points and the central axis 224. The collected light exits the tapered points of the lenses 222 to be reflected by the reflective pyramid 240.

The apparatus 220 additionally includes a light detector 244. The light detector is positioned aligned with the central axis 224 and the reflective pyramid 240.

As light is reflected from the pyramid 240, the light impinges and is detected by the light detector 244.

One or more of the lenses 222 may include an angled or beveled upper, outer perimeter 251. The angled perimeter 251 directs light impinging on the angle towards the central axis 224 and the pyramid 240 to be reflected to the detector 244.

One or more of the lenses 222 may include lead apertures 250. The light source leads 252 extend from the light source 232 through the lead apertures 250 allowing coupling to a controller, microprocessor or other circuit components for driving the light source 232.

The apparatus 220 has a low height 256 making the apparatus 220 easier to use, reducing potential for movement, simplifies securing to a subject, and more accurately maintains a positioning on the subject.

FIG. 8 depicts a cross-sectional view of an alternate embodiment of the apparatus 220 shown in FIGS. 6 and 7. In the embodiment shown, the lenses 222 taper to a blunt end 253 proximate the reflective pyramid 240. Collected light propagated through the lenses 222 exit the blunt ends 253 to be reflected by the pyramid 240 to impinge on the detector 244.

FIG. 9 shows a planer view of the contact portion of a vital sign monitoring apparatus 260 that contacts the skin of a subject being measured and/or monitored. FIG. 10 shows a cross-sectional view of the vital sign monitoring apparatus 260. The apparatus 260 includes a plurality of light pipe lenses 262 extending generally from a central point or axis 264. Each light pipe lens 262 has a light collecting surface 266. The light collecting surfaces 266 are positioned proximate to or in contact with the skin of a subject being monitored when the apparatus 260 is in use. Each light pipe lens 262 additionally includes an exterior surface 270 that is positioned away from the subject's skin. In one embodiment, the exterior surface 270 and an interior surface 274 are highly polished and/or include a reflective surface for reflecting the collected light and maintaining the collected light within the lens to be directed to a light detector 272. The reflective surface can be a coating or other covering that reflects

the spectrum of light being emitted by one or more light sources 278, such as a vacuum deposited aluminum, a highly polished stainless steel, and other reflective materials or combinations of materials. The outer surface 270 can be curved to aid in directing collected light toward the detector 272.

The apparatus 260 additionally includes an opaque region 282. The opaque region 282 may be formed within each individual light pipe lens 262, or as a separate component for mounting the light source(s) 278. In one embodiment, the opaque region 282 has a generally cone or pyramid shape. The opaque region can additionally include reflective surfaces at the interface with the interior surface 274 of the light pipe lenses 262. The opaque region has a radius 284 that is sufficiently wide to minimize direct illumination from the light source 278.

In operation, light is emitted by the light source 278 into the skin of the subject where it is modulated and reflected. At least a portion of the reflected light is collected by the collecting surface 266 of the light pipe lenses 262. The collected light is directed through the light pipe lenses to impinge on the detector 272. The cone or pyramid shape of the opaque region 282 aids in reflecting and directing the collected light towards the detector 272. In one embodiment, the lenses 262 are mounted or secured with the opaque region 282 with glue, epoxy, snap-and-fit, tongue-and-groove and substantially any other method for securing.

The apparatus 260 is configured to have a relatively low height 290 as compared with previous vital sign monitoring apparatuses. Typically the height is less than 20 mm, preferably less than 15 mm and more preferably less than 10 mm. The low height allows for easier use, less interference with patient movement, more accurate monitoring due to less movement of the apparatus 260 and a greater versatility in implementation for performing a wide range of noninvasive bio-sensing measurements at the surface of the skin in human and/or animal subjects.

FIG. 11 shows a side view of a vital sign measurement apparatus 310 according to another embodiment of the invention. FIG. 12 shows a planer view of a contact portion 312 of the vital sign measuring apparatus 310 that contacts the skin of

a subject being measured and/or monitored. The apparatus 310 has a similar configuration as the apparatus shown in FIGS. 1-4. However, the apparatus 310 shown in FIGS. 11 and 12 replace the one or more light pipes with one or more fiber optic rings, where each ring comprises a plurality of plastic or glass fiber optic cables 314. The fiber optic cables 314 are positioned circumferentially about an opaque region or disk 316. The fiber optic cables 314 extend away from the contact portion 312 forming a cone or bell shape. The fiber optic cables 314 are held together at the apex 324 with a ferule 326. An optical detector 322 is fixed with the apparatus 310 at the apex 324 and/or ferule 326 such that the light collected by the fiber optic cables 314 is directed to impinge on the optical detector 322. The optical detector 322 can be substantially any optical signal detector, such as a photo diode, phototransistor or other optical detector. The optical detector 322 can be fixed or secured with the fiber optic cables 314 and/or ferule 326 through substantially any means, such as epoxy, tongue-and-groove, a mounting in which the detector is fixed and substantially any other means for securing. In one embodiment, the optical detector 322 is attached to the fiber optic cables 314 and/or sensor lens apparatus using an optically clear epoxy resin that provides adhesion and optimal optical properties at the spectra being presented to the optical detector 322.

One or more light sources 320 are positioned and secured to the opaque region 316. The light source 320 can be a plurality of LEDs, one bi-colored LED or other similar light sources. Light emitted by the light source 320 is modulated and reflected by the blood, blood vessels, capillaries and other tissue. At least some of the reflected light enters some of the ring(s) of fiber optic cables 314 and is carried by the fiber optic cables 314 to the optical detector 322, such as a photo diode. The optical signals are measured by the optical detector 322 and the levels of received light are forwarded to a processor, microprocessor or controller (not shown) for analysis and/or display.

FIG. 13 depicts a simplified planer view of a contact surface 432 of a vital sign measuring sensor 430 according to another embodiment of the invention. FIG. 14 depicts a side view a light propagation guide or lens 434 of the vital sign sensor 430. FIG. 15 depicts a simplified cross-sectional view of the light propagating lens

434. In the embodiment shown, the light collecting and propagating lens 434 is configured generally in a "Q" configuration. With this lens assembly, the present sensor apparatus 430 can be produced with a height or thickness 440 of less than 1/2 an inch, typically less than 1/3 of an inch, and a diameter 442 of less than 2.0 inches, typically less than 1.5 inches. The small size of the sensor 420 allows it to be utilized in any number of situations and on substantially any portion of a subject's body to obtain the vital sign measurements. The invention provides a lens 434 with improved light gathering capabilities.

Still referring to FIGS. 13-15, the sensor apparatus 430 includes one or more light sources 450, such as one or more LEDs, or bi-colored LED. The light source 450 is positioned generally in the center of an opaque region or disk 452 and emits light to illuminate subcutaneous tissue having arterial/pulsing blood flow. The opaque region 452 minimizes the amount of direct light collected and propagated by the light collecting lens 434. The light collecting lens 434 is positioned circumferentially about the opaque region 452.

The light collecting lens 434 can be formed of substantially any material capable of collecting and propagating light, including glass, plastic, polycarbonate, water clear polycarbonate plastic and other similar materials or combination of materials. The light collecting lens includes a plurality of reflective elements 456 distributed along the length of the lens. The reflective elements 456 may be formed within the lens or can be notches or apertures extracted or etched from the lens. A reflective material may be secured or coated on the outer surface 460 of the reflective elements 456 to increase their reflectivity. In operation, light 436 reflected or back scattered by arterial/pulsing blood flow enters the light collecting lens 434 through a collector surface 462. The light 436 impinges upon the reflective elements 456 which direct the light along the lens 434. The light is maintained within the lens as it continues to propagate along the lens to impinge on a detector 466. The "Q" configuration provides a large light collecting surface 462 to optimize the collected light and thus the measured light. The Q configuration additionally allows the sensor 430 to have a low profile or height 440 compared with previous vital sign optical sensors. In another configuration of the "Q" lens, the serrations are eliminated and a

layer is provided at surface 462 to direct light into the axis of the large diameter fiber optic lens.

FIG. 16 shows a simplified block diagram of a functional signal flow for a data acquisition system 520 according to an embodiment of the invention. FIG. 17 shows a sample of a timing diagram for the operation of the vital sign monitor or sensor 120, 222, 260, 310, 430 (see FIGS. 1, 6, 10, 11 and 13, respectively) and data acquisition system 520. The data acquisition system 520 couples with the light source(s) and light detector. A controller, microcontroller or microprocessor 522 provides control functions for signal timing and data flow. The microcontroller 522 provides timing to sample the data from the one or more detectors. In one embodiment, the microcontroller 522 provides timing to sample at approximately 200 times each second 100 samples each for the RED and IR channels. However, other sample rates can be equally applied.

Prior to activating a light source, a sample 570 (see FIG. 17) of the background or ambient light level is taken from the detector 524 and held in a background light sample and hold circuit 526. The controller 522 then activates a light source drive 530 to drive a light source to emit a light 572, for example an LED is activated to emit a red or other selected light spectra. The light source drive 530 activates the light source for a predefined period of time  $t_{red}$  (and similarly for the IR pulse  $t_{IR}$ ). The detector 524 detects the light as it is reflected and modulated from the subject's blood, arteries and other tissue. The detector 524 generates a signal proportional to the amount of detected light.

Background circuit 526 subtracts the background light from the measured light signal. The background adjusted signal is amplified through a gain and buffer stage 532. The gain provided can be substantially any gain, for example, the gain and buffer stage can provide a gain of three (3). At the output of the gain stage 532 the output signal is divided into two channels by the pulse timing signals generated in the microcontroller 522.

A first output signal 534 is directed to an automatic gain control (AGC) 540. The AGC 540 utilizes the detected light signal to set the drive current to the light source(s). This is achieved, at least in part, by setting the pulse amplitude of the detected signal from each of two light spectra to substantially the same level. This aids in assuring the accuracy of the data processing in determining blood oxygen saturation levels. In one embodiment, the AGC 540 sets the amplitude such that the detected pulses are approximately 90% of amplifier saturation.

In addition to the AGC 540 circuitry, the second output signal 536 of the gain stage 532 is supplied to an input of two peak detectors 542, 544 and two differential amplifiers 546, 550. The first peak detector 542 and the first differential amplifier 546 correspond to a first light spectra signal (e.g., a red spectra (RED)) and the second peak detector 544 and second differential amplifier 550 correspond to a second light spectra signal (e.g., a near infrared spectra (IR)).

The spectra select circuitry 552 determines which of the two spectra circuitry (i.e., 542 and 546, or 544 and 550) is active. When the RED circuitry (544 and 550) is active 572 the amplitude of the pulse pedestal of the RED peak detector 544 output is sampled 576 and forwarded to one input of the RED differential amplifier 550. Similarly, when the IR circuitry (542 and 546) is active 574 the amplitude of the pulse pedestal of the IR peak detector 542 output is sampled 580 and forwarded to one input of the IR differential amplifier 546. The peak detectors are designed with a time constant that is sufficiently long so as to not follow the variations of the pulsing modulation from the detected optical signal. This assures that the average DC level of the detected signal is maintained at one input to differential amplifiers 546 and 550 and that the modulated signal will be amplified.

The output of the peak detector circuitry 542, 544 is maintained at an approximate average peak of the incoming pulses from the selected spectra. In one embodiment, the peak detector is implemented, at least in part, through a low frequency filter that does not have to be reset periodically. This is due primarily to charge leaking off a holding capacitor.

The output of the RED and IR differential amplifiers 550, 546, respectively, are sampled 582, 584 by sample and hold circuitry 554, 556. The sample rates of the sample and hold circuitry 554, 556 are controlled by the microcontroller 522, for example at 100 samples per second.

The output of the differential amplifiers 546, 550 are the differences between the output of the peak detectors 542, 544 and the second output signal 536 of the gain stage 532, which is the amplitude of the current detected pulse (e.g., active RED or active IR). The light source is then turned off 586 (RED) or 590 (IR) and the sampled signal (RED or IR) is digitized 592, 594 through an analog to digital converter (ADC) 560. In one embodiment, the ADC 560 is implemented through a 12-bit ADC. The output of the ADC 560 can be supplied to an external processor 562, a display, some other circuitry configured to utilize the data or a combination thereof. The signal processing can be performed through substantially any device configured to provide the needed processing, such as a hospital equipment device, a personal computer (PC), micro-computing device or other device for processing. In other embodiments, many of the analog functions are shifted into a digital system, for example utilizing data acquisition and signal processing technology available in single chip devices.

The sequence of generating the digital signal is alternately repeated between the plurality of light spectra, for example between the RED spectra light and the IR spectra light. Following the data acquisition sequence of either spectra (RED or IR) or a pair of spectra (RED and IR) there is a short delay 596 before the process is repeated, with the background light being measured 570 prior to activating the IR 574 or RED 572 light source.

Modulation of the detected pulse amplitude is typically negative due to the variation in the absorption of back scattered light. More light is being absorbed during the peak inflow of blood pulses. It is the ratio of this absorption over time that provides, in part, the determination of the vital signs, such as blood oxygen saturation and heart rate.

FIG. 18 shows a small sample of measured data taken by the apparatus and/or system 120, 430, 520 (see FIGS. 1, 13 and 16). The lines 610, 612 in the data represent the RED and IR signals from the data acquisitions system.

The vital sign measuring apparatus 120, 220, 260 (FIGS. 1, 6 and 8, and the other embodiments shown and described) can additionally include a temperature sensing device. In one embodiment, the temperature sensing device is implemented through a resistance temperature device (RTD) or single chip silicone temperature sensor. In some embodiments, the opaque disk or region provides temperature sensing or includes a temperature sensor.

In operation, the detected light is forwarded to a processor for determining the vital signs of the subject. In some embodiments, signal processing algorithms used to determine blood oxygen saturation were taken from textbooks and papers gathered from the proceedings of the Institute of Electrical and Electronics Engineers (IEEE). In some embodiments, the algorithms used for determining heart rate of a subject also employ signal processing techniques currently in common use.

In one embodiment, the data acquisition system 520 (see FIG. 16) is designed to reference the detected pulse signal to a reference level (e.g., to a DC ground) by subtracting the measured ambient light from the detected reflected light. The reference level of the detected signal is set in the background circuit 526 as already described. The reference level of the signal is the value stored in the peak detector 542, 544 as applied to the inputs of the differential amplifiers 546 & 550.

Still referring to FIGS. 17 and 18, the variable or AC, component of the signal represents the variations in pulse amplitude resulting from modulation of back scattered light presented to the detector in the sensor assembly. The peak pulse amplitude of signals derived from the first spectra signal (e.g., 660nm) and second spectra signal (e.g., 940nm) are maintained at substantially the same amplitude by the AGC circuitry 540. This value is provided to the microcontroller 522 and/or external processing system 560. A running average of the peak values and minima's of both spectra signals is stored and processed to derive the ratio of absorption coefficients.

The oxygen saturation in the arterial blood is determined, in one embodiment, utilizing a ratio defined by:

$$\text{SaO}_2 = A - B (Y_{\text{spectra}_1} / Y_{\text{spectra}_2}); \quad (\text{Eq. 1})$$

where,

$$Y_{\text{spectra}_1} = \log(\text{DC}_{\text{spectra}_1} + \text{AC}_{\text{spectra}_1}) / \log(\text{AC}_{\text{spectra}_1}), \text{ and}$$

$$Y_{\text{spectra}_2} = \log(\text{DC}_{\text{spectra}_2} + \text{AC}_{\text{spectra}_2}) / \log(\text{AC}_{\text{spectra}_2}).$$

Resulting calculations produce ratio values of the detected first and second spectra signals (e.g., 660nm and 940nm). In one embodiment, the ratio values are adjusted using calibration coefficients that are dependent upon the individual apparatus/circuitry utilized in measuring the reflected light and determining the ratio. The ratio of absorption is used in determining the level of oxygen saturation in arterial blood according to Equation 1.

Heart rate information is extracted from one or more of the detected data streams. The present invention can utilize one or more of a number of different methods for determining heart rate. In one embodiment, the period between pulse minima's is measured based on the sampling rate and averaged over a period of time (e.g., five to ten second period) to generate an indication of heart rate in beats per minute. More complex methods using time to frequency techniques such as Fast Fourier Transforms (FFT) and auto correlations for filtering and noise rejections can also be employed.

There are a number of reflectance pulse oximeters currently being sold to hospitals, clinics and individuals. These are normally placed somewhere on the head preferably in the center of the forehead. Attachment of these devices to a patient requires the use of adhesives or tapes that are prone to damage delicate skin (e.g., skin of newborn infants) when they are removed. In one embodiment, the present invention does away with the adhesives by installing the sensor in a blanket assembly 620. The blanket assembly can additionally contain exotherming gel that can be activated prior to use. FIG. 19 shows a blanket assembly 620 in use on a patient 622 incorporating an optical vital sign measuring apparatus 624. In one embodiment, the

blanket 620 is designed like a wrap that can be folded over to keep the patient from losing body heat, for example over an infant immediately after birth, with a vital sign monitor or sensor apparatus 624 being placed so that it makes intimate contact with the patient's skin. The sensor 624 couples with a processor 626 that determines the vital signs, such as blood oxygen saturation, heart rate, temperature, based on measured results and displays the vital signs on a display 630. The blanket can be configured with a main portion 630 with first and second lateral wrap flaps 632 and 634 extending away from each other on opposite sides of the main portion 630. the blanket can additionally include a third wrap flap 636 extending from the main portion 630, perpendicular to the extended first and second flaps. The three flaps allow the blanket to be quickly, easily and securely wrapped around the patient 622. The flaps can additionally include means for securing such as Velcro, snaps, loops-and-hooks, buttons and other fasteners.

While the invention herein disclosed has been described by means of specific embodiments and applications thereof, numerous modifications and variations could be made thereto by those skilled in the art without departing from the scope of the invention.

I CLAIM:

**CLAIMS**

What is claimed is:

1. An optical vital signs apparatus, comprising:  
a light source;  
a light pipe having a collecting surface and a terminal end, the light source being positioned proximate the collecting surface; and  
a light detector positioned proximate the terminal end.
2. The apparatus of claim 1, wherein the light source is capable of generating pulsed illumination at a first spectra and a second spectra.
3. The apparatus of claim 2, wherein the first spectra is 660 nm and the second spectra is 940 nm.
4. The apparatus of claim 1, wherein the light source includes a first light source capable of generating pulsed illumination at a first spectra and a second light source capable of generating pulsed illumination at a second spectra.
5. The apparatus of claim 4, wherein the first spectra is 660 nm and the second spectra is 940 nm.
6. The apparatus of claim 1, further comprising a light guard.
7. The apparatus of claim 6, wherein the light guard is an opaque region positioned about the light source.

8. The apparatus of claim 7, wherein the light guard includes an exterior perimeter and the collecting surface of the light pipe is positioned about at least a portion of the exterior perimeter.

9. The apparatus of claim 1, wherein the light pipe is configured to direct light impinging on the collecting surface to impinge on the light detector.

10. The apparatus of claim 9, wherein the light pipe further includes a reflective outer surface.

11. The apparatus of claim 9, wherein the light pipe further includes an interior portion with a reflective inner surface.

12. The apparatus of claim 9, wherein the light pipe further includes a reflective pyramid positioned between the terminal end and the light detector.

13. The apparatus of claim 9, wherein the light pipe includes a unitary light pipe.

14. The apparatus of claim 9, wherein the light pipe includes a plurality of optical wave guides.

15. The apparatus of claim 9, wherein the light pipe includes a plurality of light pipes.

16. The apparatus of claim 9, wherein the light pipe includes a plurality of fiber optic cables.

17. The apparatus of claim 16, wherein the light pipe further includes a ferule proximate the terminal end holding the plurality of optical wave guides.

18. The apparatus of claim 9, wherein the light pipe material is selected from the group consisting of poly carbonate, water clear poly carbonate, plastics, glass, and any other material or combination of materials capable of directing light.

19. The apparatus of claim 1, wherein the collecting surface includes a plurality of reflective elements.

20. The apparatus of claim 19, wherein the of reflective elements are formed, notched, extracted or etched in the collecting surface.

21. The apparatus of claim 1, wherein the light pipe tapers to a point at the terminal end.

22. The apparatus of claim 1, further comprising a controller.

23. The apparatus of claim 22, wherein the controller is coupled to the light source and light detector.

24. The apparatus as claimed in claim 1, further comprising a blanket wherein the light source, light pipe and light detector are secured within the blanket.

25. A method for measuring a person's vital sign using an optical vital signs apparatus, the optical vital signs apparatus including:

a light source;

a light pipe having a collecting surface and a terminal end, the light source being positioned proximate the collecting surface; and

a light detector positioned proximate the terminal end;

the method comprising:

placing the optical vital signs apparatus proximate the person's skin,

illuminating the skin with the light source;

collecting reflected light on the collecting surface;

propagating the reflected light through the light pipe to the light detector;

detecting the amount of reflected light with the light detector; and

determining the person's vital sign.

26. The apparatus of claim 25, wherein the vital sign is the blood oxygen saturation level.

27. The apparatus of claim 25, wherein the vital sign is the heart rate.

28. A method for performing optical vital sign measurements, comprising:

- detecting a first amount of background light;
- generating a first optical signal at a first spectra;
- detecting a first amount of the first optical signal reflected;
- subtracting the first amount of background light from the first amount of the first optical signal detected;
- determining a first average peak of the first amount of the first optical signal detected;
- determining a first difference between the first amount of the first optical signal detected and the average peak;
- sampling the first difference;
- detecting a second amount of background light;
- generating a second optical signal at a second spectra;
- detecting a second amount of the second optical signal reflected;
- subtracting the second amount of background light from the second amount of the second optical signal detected;
- determining a second average peak of the second amount of the second optical signal detected;
- determining a second difference between the second amount of the second optical signal detected and the second average peak;
- sampling the second difference;
- processing the first and second difference; and
- determining an oxygen blood saturation level.

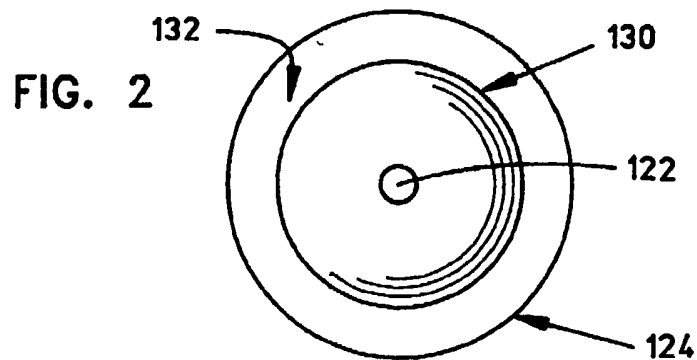
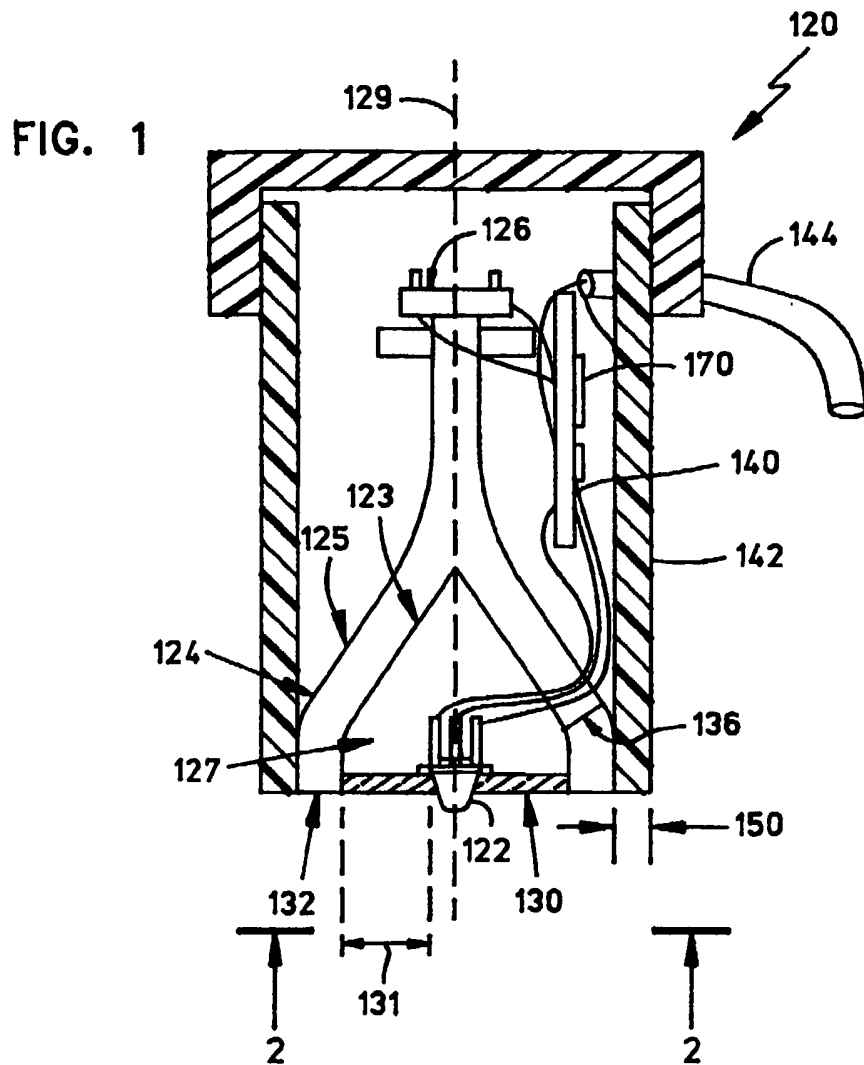

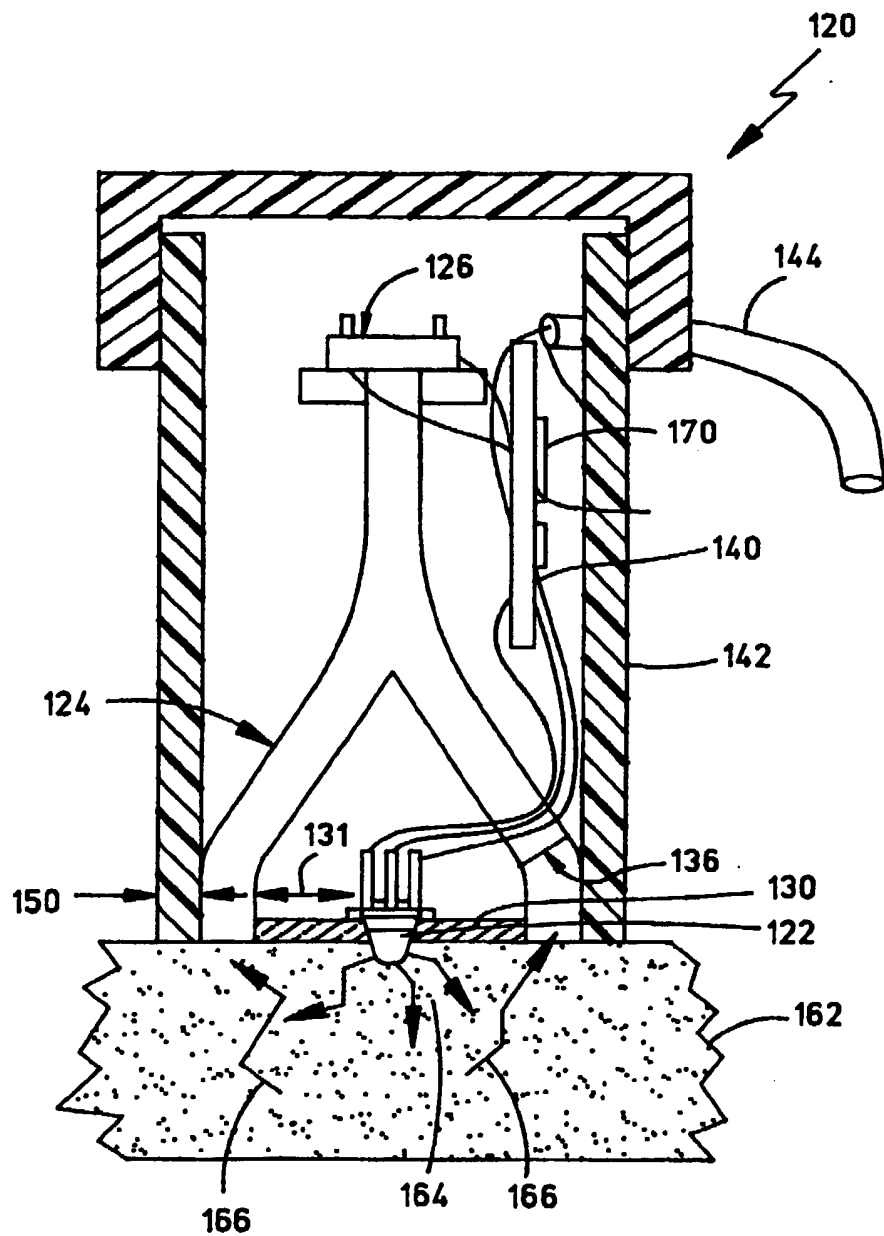

FIG. 4

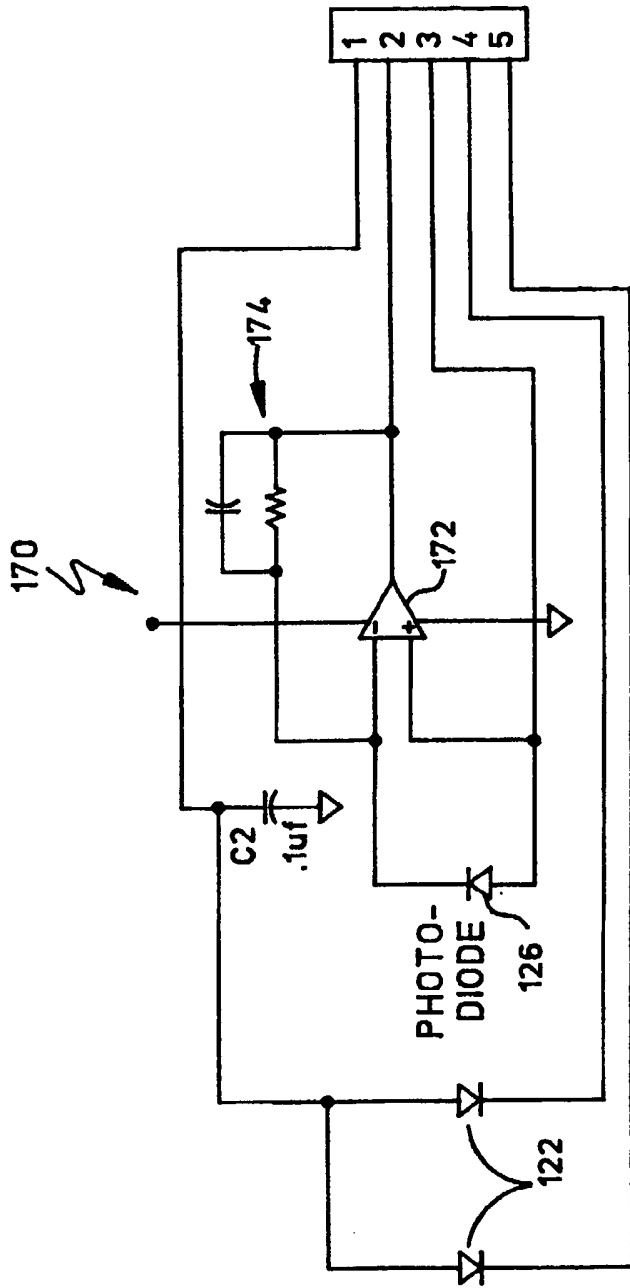

FIG. 3

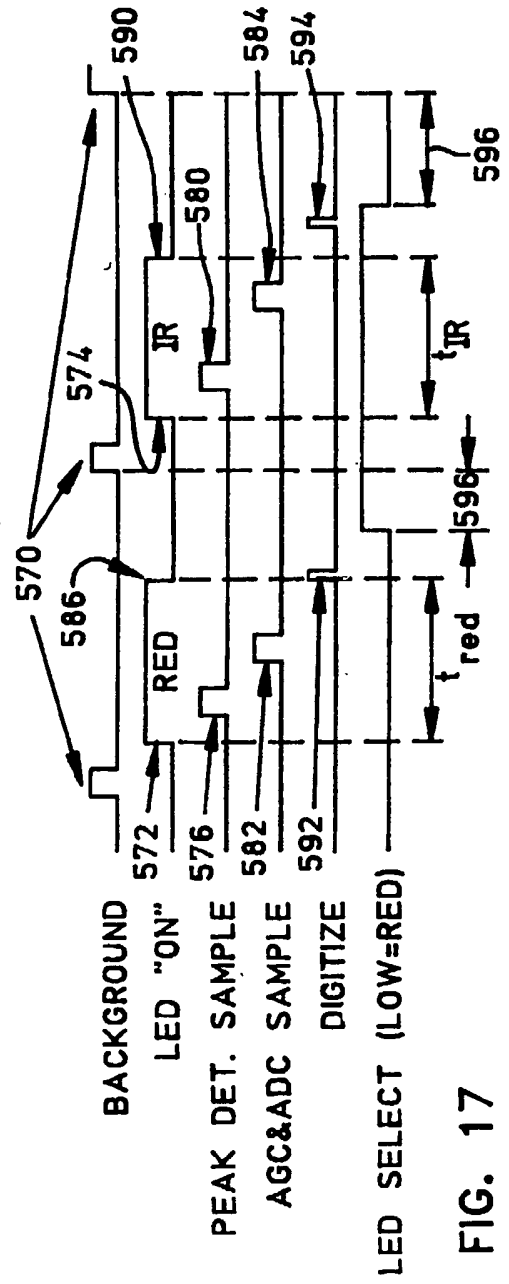

FIG. 17

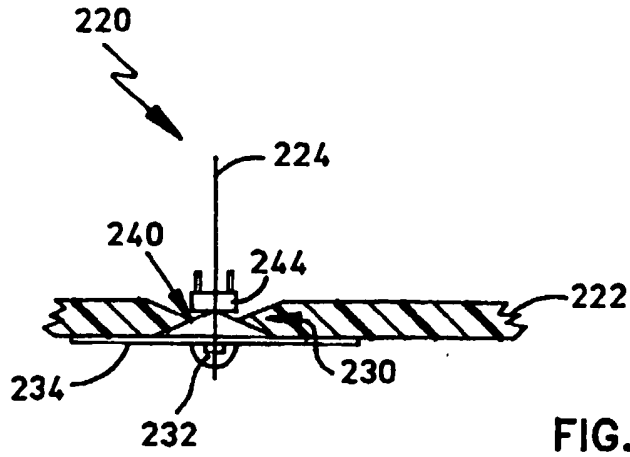

FIG. 5

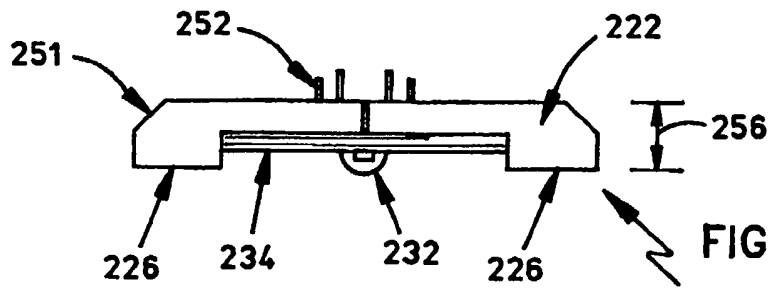

FIG. 6

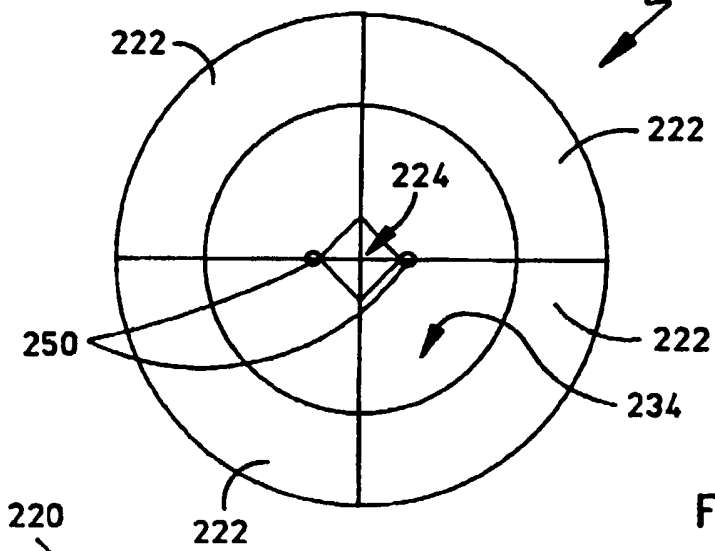

FIG. 7

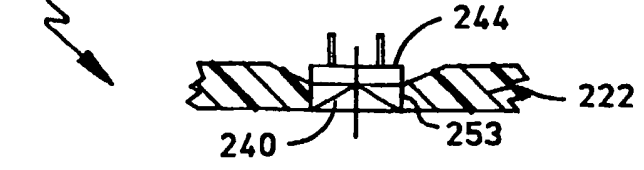

FIG. 8

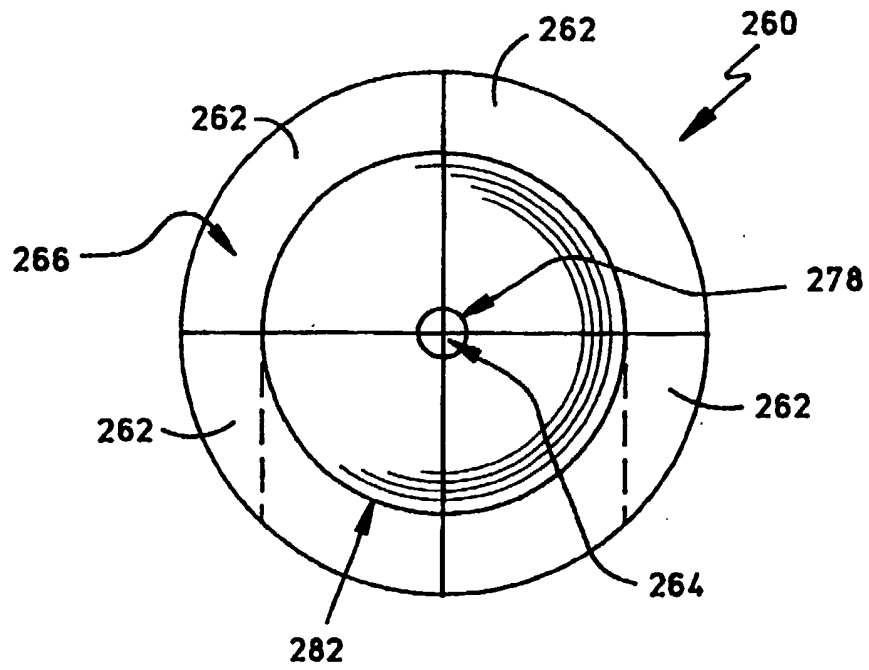

FIG. 9

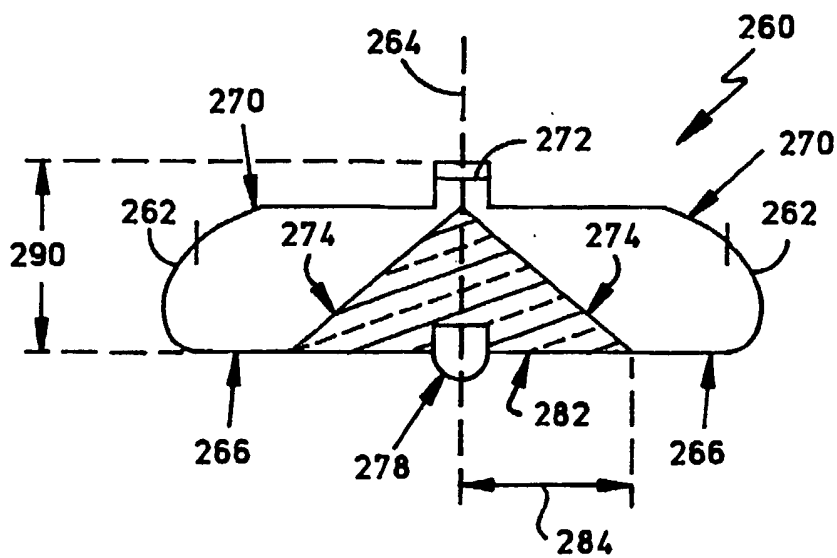

FIG. 10

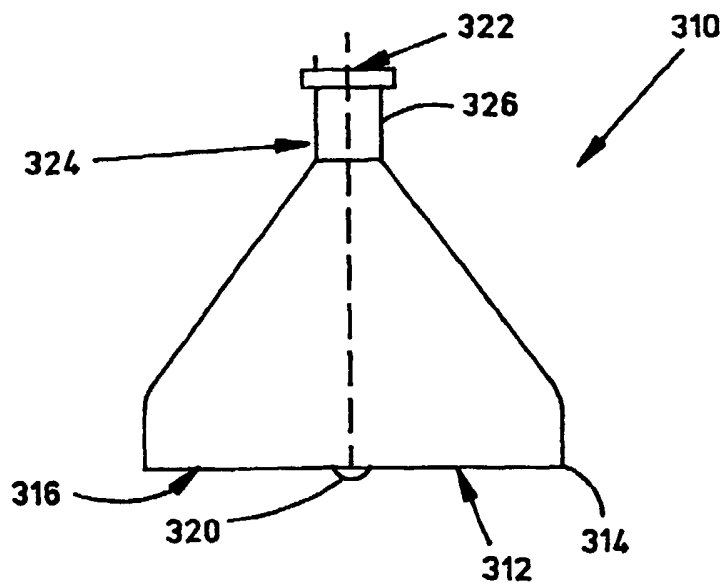

FIG. 11

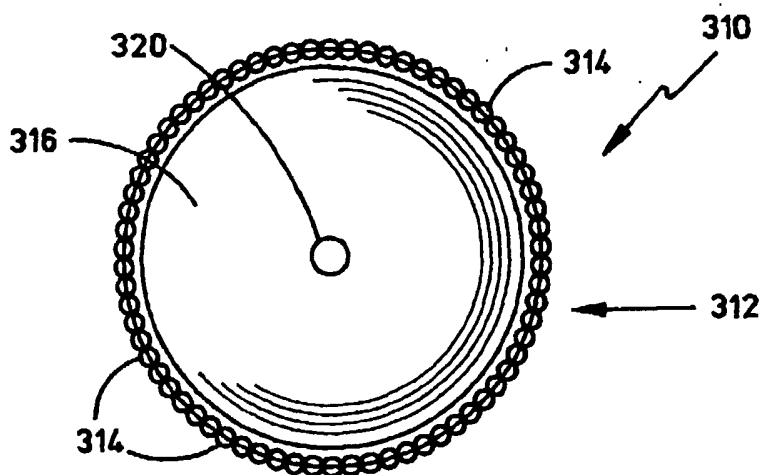

FIG. 12

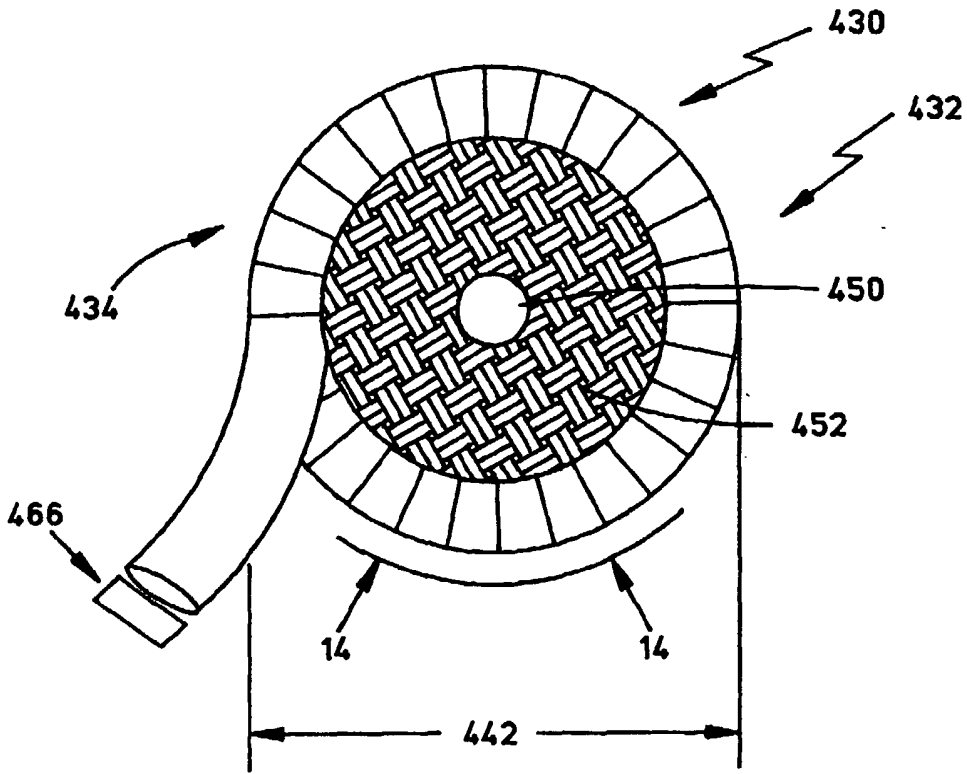

FIG. 13

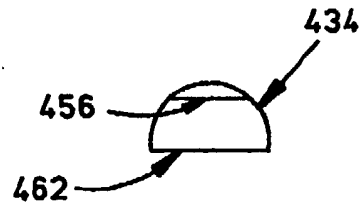

FIG. 15

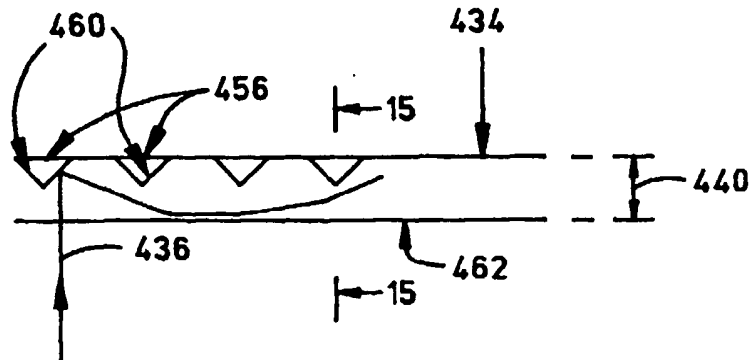

FIG. 14

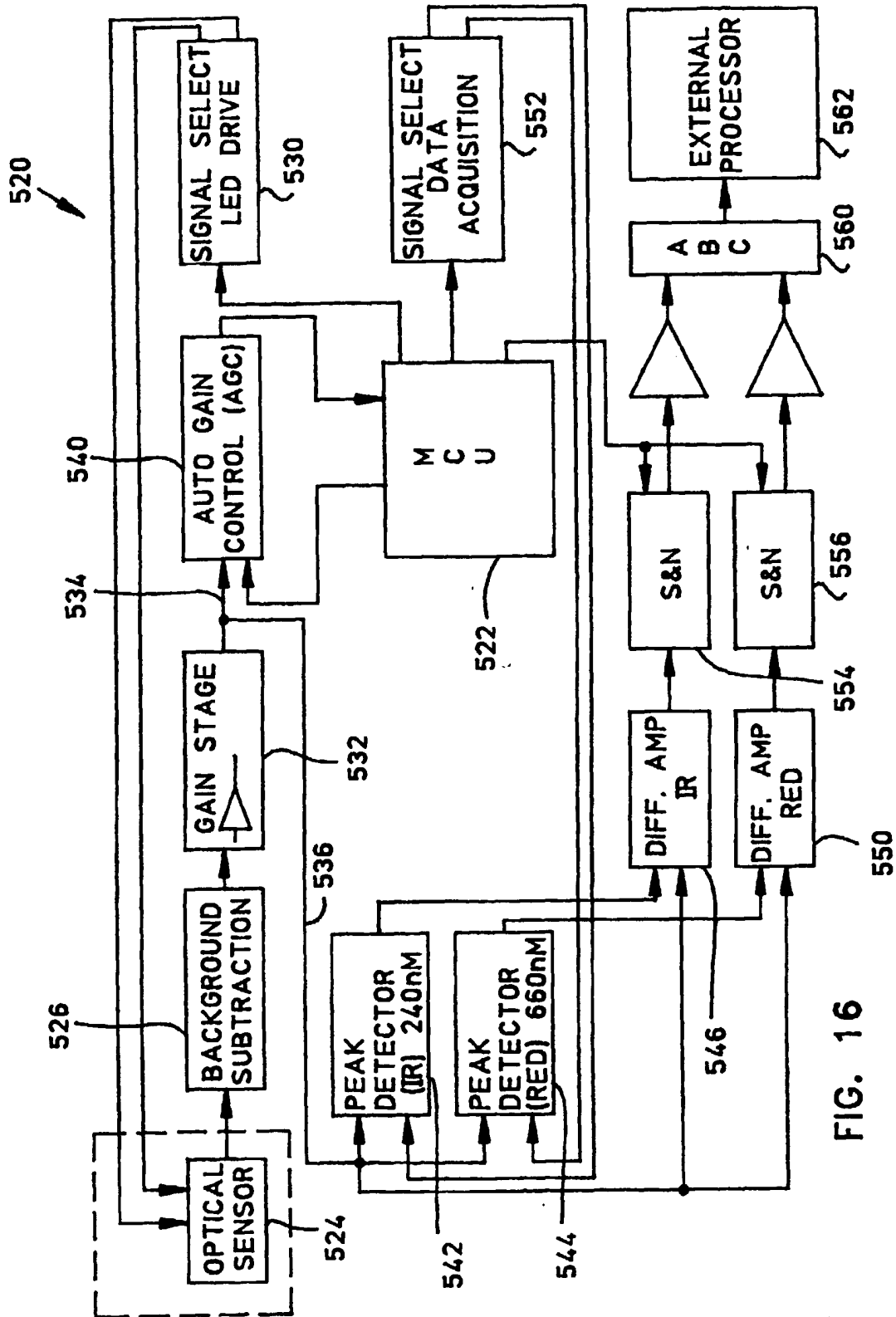

FIG. 16

