

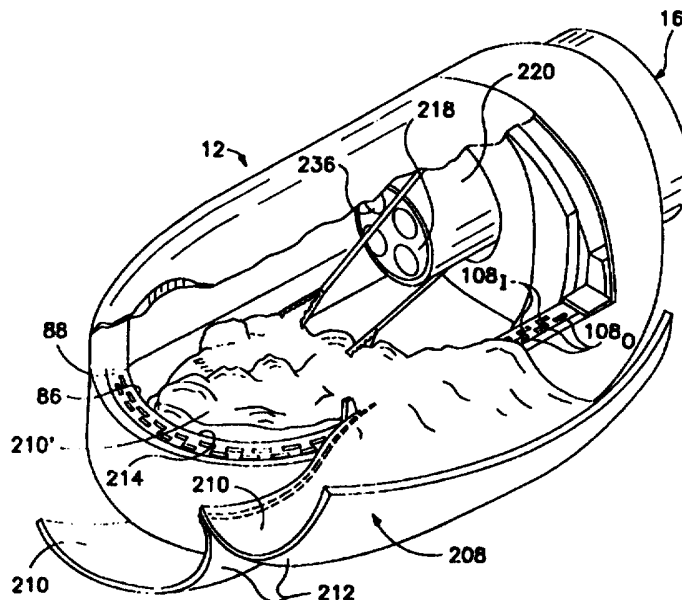

INTERNATIONAL APPLICATION PUBLISHED UNDER THE PATENT COOPERATION TREATY (PCT)

<p>(51) International Patent Classification⁶ : A61B 17/04</p>	<p>A2</p>	<p>(11) International Publication Number: WO 96/18344 (43) International Publication Date: 20 June 1996 (20.06.96)</p>
<p>(21) International Application Number: PCT/US95/15870 (22) International Filing Date: 5 December 1995 (05.12.95) (30) Priority Data: 08/352,325 7 December 1994 (07.12.94) US (71) Applicant: McGUCKIN, James, F., Jr. [US/US]; 419 Spring Mill Road, Villanova, PA 19085 (US). (74) Agent: QUINN, Charles, N.; Dann, Dorfman, Herell & Skillman, P.C., Suite 720, 1601 Market Street, Philadelphia, PA 19103-2307 (US).</p>		<p>(81) Designated States: AM, AT, AU, BB, BG, BR, BY, CA, CH, CN, CZ, DE, DK, EE, ES, FI, GB, GE, HU, IS, JP, KE, KG, KP, KR, KZ, LK, LR, LT, LU, LV, MD, MG, MN, MW, MX, NO, NZ, PL, PT, RO, RU, SD, SE, SG, SI, SK, TJ, TM, TT, UA, UG, UZ, VN, European patent (AT, BE, CH, DE, DK, ES, FR, GB, GR, IE, IT, LU, MC, NL, PT, SE), OAPI patent (BF, BJ, CF, CG, CI, CM, GA, GN, ML, MR, NE, SN, TD, TG), ARIPO patent (KE, LS, MW, SD, SZ, UG). Published <i>Without international search report and to be republished upon receipt of that report.</i></p>

(54) Title: APPARATUS AND METHOD FOR PERFORMING COLON/RECTAL SURGERY



(57) Abstract

Surgical method and apparatus (12) for resectioning tissue (210), preferably luminal tissue (208), with a remaining portion of an organ being anastomosed with staples or other fastening means, preferably endolumenally. The apparatus may be inserted via a naturally occurring body orifice or a surgical incision and then advanced using either endoscopic or radiological imaging guidance to an area where surgery is to be performed. Under endoscopic or diagnostic imaging guidance the apparatus is positioned so tissue (208, 210) to be resected is manipulated into an inner cavity of the apparatus. The apparatus then cuts the diseased tissue after stapling and retains the diseased tissue within the apparatus. The rent resulting in a border of healthy tissue is anastomosed with surgical staples.

FOR THE PURPOSES OF INFORMATION ONLY

Codes used to identify States party to the PCT on the front pages of pamphlets publishing international applications under the PCT.

AT	Austria	GB	United Kingdom	MR	Mauritania
AU	Australia	GE	Georgia	MW	Malawi
BB	Barbados	GN	Guinea	NE	Niger
BE	Belgium	GR	Greece	NL	Netherlands
BF	Burkina Faso	HU	Hungary	NO	Norway
BG	Bulgaria	IE	Ireland	NZ	New Zealand
BJ	Benin	IT	Italy	PL	Poland
BR	Brazil	JP	Japan	PT	Portugal
BY	Belarus	KE	Kenya	RO	Romania
CA	Canada	KG	Kyrgystan	RU	Russian Federation
CF	Central African Republic	KP	Democratic People's Republic of Korea	SD	Sudan
CG	Congo	KR	Republic of Korea	SE	Sweden
CH	Switzerland	KZ	Kazakhstan	SI	Slovenia
CI	Côte d'Ivoire	LI	Liechtenstein	SK	Slovakia
CM	Cameroon	LV	Latvia	SN	Senegal
CN	China	LU	Luxembourg	TD	Chad
CS	Czechoslovakia	LV	Latvia	TG	Togo
CZ	Czech Republic	MC	Monaco	TJ	Tajikistan
DE	Germany	MD	Republic of Moldova	TT	Trinidad and Tobago
DK	Denmark	MG	Madagascar	UA	Ukraine
ES	Spain	ML	Mali	US	United States of America
FI	Finland	MN	Mongolia	UZ	Uzbekistan
FR	France			VN	Viet Nam
GA	Gabon				

-1-

**APPARATUS AND METHOD FOR
PERFORMING COLON/RECTAL SURGERY**

Field of the Invention

5 This invention relates to surgical apparatus and procedures and specifically to surgical apparatus and procedures for resectioning, preferably endolumenally, diseased or otherwise undesirable portions of luminal or other tissue and anastomosing remaining, healthy luminal or other tissue.

10 **Summary of the Invention**

In one of its aspects this invention provides apparatus for endolumenally resectioning a diseased portion of luminal tissue in a manner that remaining luminal tissues are anastomosed with fastening means.

15 In such aspect the apparatus includes means for gripping histologically normal luminal tissue, preferably at axially separated positions on respective sides of the diseased tissue of interest, and pulling the gripped tissue via mechanical compression with traction or via

20 suction, i.e. negative pressure with traction, into a cutting zone removed from an undisturbed portion of the luminal tissue. Since the diseased or other undesirable tissue of interest is surrounded by the gripped histologically normal tissue, the diseased or other

25 undesirable tissue of interest is pulled into and preferably across the cutting zone.

The apparatus further preferably includes means for detaching the diseased luminal tissue from surrounding healthy luminal tissue and further fastening tissue

30 together so that healthy luminal tissue is fastened about and across an aperture in the luminal wall, which aperture would otherwise be created by detachment of the diseased or otherwise undesirable luminal tissue from

-2-

the healthy luminal tissue, in a manner to close the aperture. The tissue fastening and detaching means preferably operates to fasten the healthy tissue together before cutting the diseased or otherwise
5 undesirable tissue therefrom in a manner minimizing chances for diseased tissue subsequently contacting healthy tissue and further minimizing likelihood of any aperture remaining for leakage of material through the tissue wall from which the diseased or undesired tissue
10 was removed.

Preferably in one embodiment of the apparatus aspect of the invention the cutting means portion of the apparatus includes a longitudinally elongated blade which preferably translates along a longitudinal axis
15 respecting the remainder of the apparatus and respecting a lumen into which the apparatus has been inserted. In a stapling and cutting aspect of the invention, the invention is not limited to a single length stapling and cutting operation. The stapling and cutting operation
20 may be along only a limited portion of the stapling and cutting path so that if the objective of the surgery is removal of a polyp or perhaps the appendix, where the tissues to be removed are relatively small and/or encountered in a head-on orientation, the operating
25 physician or other attending health professional may adjust and control the length of the path over which tissue stapling and cutting is performed.

The preferably intraluminal operation of a capsule facilitates passage of a conventional endoscope through
30 the operating capsule in a manner that the endoscope may be considered to "snake" or "telescope" into and out of the capsule, moving preferably essentially coaxially with the capsule and a tubular connection member via which the capsule communicates with an operating control
35 module. The endoscope allows the operator visually to guide the operating capsule up the lumen, with the

-3-

endoscope preferably protruding from the end of the capsule via an aperture remote from the operating control module to provide excellent vision for an operator.

5 Once the operator, using the endoscope and the view afforded thereby, has guided the capsule up the lumen to the desired position, the endoscope may be withdrawn into the capsule to permit the operator to observe the tissue grasping, stapling and cutting operation
10 performed by the operating capsule from within the capsule. After the diseased or otherwise undesirable tissue is cut and separated from surrounding healthy tissue, the capsule may be opened thereby permitting the operator to observe the wound and the stapling closure
15 thereof with the endoscope and further to cauterize any bleeding blood vessels as needed. Even if there is no bleeding, the operating capsule may still be opened to allow inspection of the wound site using the endoscope in order that the operator may be sure there are no
20 apertures or other sites where leakage could take place through healthy lumen wall tissue. Alternatively, the endoscope may be advanced axially out of the capsule, further up the lumen from the capsule to observe the wound and the stapling closure thereof from outside the
25 capsule.

In yet another aspect this invention provides apparatus for endoluminally removing a cylindrical wall section of undesired luminal tissue and circumferentially securing remaining luminal wall tissue
30 from either side about the site of cylindrical wall removal. In this aspect the apparatus preferably includes means for fastening together circular margins of luminal tissue which are adjacent to the undesired luminal tissue which will be removed as a section of
35 cylindrical luminal tissue, to prevent creation of a breach in the lumen which would otherwise result upon

removal of the undesired luminal tissue as a cylindrical section. In this aspect the invention preferably yet further includes means for cutting the undesired luminal tissue as a cylindrical section from the lumen radially inboard of the fastened together circular margins of the luminal tissue. Preferably in this aspect of the invention the tissue fastening and cutting means fastens the tissue simultaneously around the entire 360° of the circular tissue margin. In this aspect of the invention the tissue fastening and cutting means preferably cuts the tissue simultaneously around the entire 360° of the circular tissue margin. Further respecting this aspect of the invention, the tissue fastening and cutting means is preferably means for sequentially fastening and then cutting the tissue. In yet another aspect this embodiment of apparatus of the invention includes means for stapling tissue together as at least a part of the tissue fastening means.

In yet another aspect this invention provides apparatus for performing endolumenal tubular resection where the apparatus includes a continuous annular lip. Suturing means are preferably present in the lip for passing through tissue portion around the lip and thereby securing the tissue together.

In yet another aspect this invention provides methods for endolumenal full thickness resectioning of tissue by anastomosing the tissue with artificial fastening means.

One preferred practice of one of the method aspects of the invention includes inserting a tissue cutting instrument into a body lumen through a naturally occurring body orifice or a surgically created rent. A second step in the method is to advance the instrument within the lumen to an area of diseased tissue or tissues desired to be resected, where surgery is to be performed to remove the diseased tissue or to ligate a

lumen. Yet another step of the method is to suture surrounding tissue defining a wall of the lumen to close an orifice therein which would otherwise result from removal of undesirable tissue urged or drawn or manipulated into position for cutting. Yet another step of the method is the cutting of the diseased urged or drawn or manipulated tissue from surrounding tissue defining a wall of the lumen in which the instrument resides.

10 An optimal step is that of alternately urging or drawing or manipulating the tissue to be resected into an inner cavity of the instrument.

Another optional step is that of retaining the cut tissue which has been urged or drawn or manipulated within the inner cavity of the instrument in a position spaced or separated from the lumen wall. Yet another step is that of withdrawing the instrument along the lumen and from the body orifice while retaining the cut tissue which had been urged or drawn or manipulated within the inner cavity of the instrument, in a position spaced or separated from the lumen wall.

20 In still another aspect this invention provides a method for endolumenally cylindrically resectioning luminal tissue where the method includes inserting a tissue suturing and cutting instrument into a body lumen through a naturally occurring body orifice. A second step in the method is to advance the instrument within the lumen to an area of undesired luminal tissue to be cylindrically resectioned. A third step is to draw the undesired luminal tissue to be cylindrically resectioned into an annular cutting zone associated with the instrument. A fourth step is that of stapling the surrounding luminal tissue about annular margins of the cylindrical tissue to be resectioned to close an orifice which would otherwise result from removal of the undesired luminal tissue as a cylindrical section of

-6-

tissue. A fifth step is that of cutting the undesired cylindrical luminal tissue from surrounding luminal tissue.

5 An optional step in the method is that of retaining the cut undesired cylindrical luminal tissue within the instrument while withdrawing the instrument from the lumen through the naturally occurring orifice to maintain the cut undesired cylindrical luminal tissue separated from healthy luminal wall tissue.

10 In practice of this method aspect of the invention the tissue stapling is preferably performed simultaneously around the entire 360° of the tissue circular margin. Similarly, the tissue cutting step is preferably performed simultaneously around the entire
15 360° circular tissue margin.

An important aspect of the methods and the embodiments of apparatus of the invention is that suturing the tissues surrounding diseased tissue, where the surrounding tissue defines a wall of the lumen, may
20 be performed prior to cutting diseased or undesired tissue from the surrounding tissue wall of the lumen in which the apparatus of the invention resides.

An important optional aspect of the methods and apparatus of the invention is retention of the cut and
25 removed tissue within the apparatus interior, away from the lumen wall. This is important in that it minimizes chances for contact of the severed diseased or otherwise undesired tissue with the healthy tissue remaining as a part of the body and also prevents potential leakage of
30 luminal contents into surrounding body spaces.

Another important aspect of the methods and apparatus of the invention is that whereby when malignant, diseased or otherwise undesirable tissue is to be removed from the lumen wall, the entire wall
35 structure through its entire thickness may be cut and removed with no layers of tissue being excluded or left

in place. Further, the methods and apparatus of the invention facilitate complete removal of the wall tissue by reducing and effectively minimizing the opportunity for any diseased tissue to remain after resectioning has
5 been completed.

The methods and apparatus are also applicable to procedures for healthy, normal tissue such as resectioning the Fallopian tubes for sterilization.

The invention also has applicability to performing
10 appendectomies. In such case, the operator may use a balloon and a conventional endoscope together with apparatus of the invention to draw the appendix into the bowel interior and into an operating capsule portion of the apparatus of the invention without completely
15 inverting the appendix. The appendix is desirably only partially inverted; however, complete inversion is also acceptable. Once the appendix has been sufficiently drawn into the operating capsule, suturing and tissue cutting is performed at the base of the appendix with
20 the appendix being retained within the operating capsule. This procedure is particularly desirable and indicated when an appendicolith has been detected.

The methods and apparatus, while directed principally to surgery of the gastrointestinal system,
25 are also applicable to surgery for other organ systems including the genital-urinary tracts. The apparatus may also be used and the methods may be modified for use through small skin incisions so as to perform biopsies and to resect tissues remotely using endoscopic,
30 radiological or other types of imaging within a body cavity such as the thoracic cavity or the abdominal cavity. Further, endovascular surgery may be performed using the apparatus and the methods of the invention.

Brief Description of the Drawings

-8-

Figure 1, which is divided into Figures 1A and 1B, is an isometric view of a first and preferred embodiment of apparatus for removing malignant or other undesirable tissue from the wall of a lumen (such as the colon), while within the lumen (such as the colon), manifesting aspects of the invention.

Figure 1A isometrically illustrates an operating control module portion of such apparatus embodying aspects of the invention and a part of cable carrying flexible tubular apparatus also manifesting aspects of the invention.

Figure 1B isometrically illustrates a longitudinally elongated operating capsule apparatus manifesting aspects of the invention and the portion of the cable carrying flexible tubular apparatus not shown in Figure 1A.

Figure 2 is a side view of the apparatus illustrated in Figure 1 with a conventional endoscope illustrated in position within the apparatus shown in Figure 1, illustrating the manner in which an endoscope is used in conjunction with a preferred embodiment of apparatus manifesting aspects of the invention to remove malignant, other diseased or otherwise undesirable tissue from a lumen wall while within the lumen.

Figure 3 is an enlarged broken view of a portion of the cable carrying flexible tubular apparatus manifesting aspects of the invention, taken as indicated by the box labeled "Figure 3" in Figure 2.

Figure 4 is a sectional view of the cable carrying flexible tubular apparatus taken at lines and arrows 4-4 in Figure 2.

Figure 5 is a sectional view of the cable carrying flexible tubular apparatus taken at lines and arrows 5-5 in Figure 4.

Figure 6 is a side view of two conical disks, showing the disks in spaced relation, which reside

within the cable carrying flexible tubular apparatus illustrated in Figures 1A, 1B, 2, 3, 4 and 5.

Figure 7 is a broken, partially sectioned view of operating control module apparatus manifesting aspects of the invention taken at lines and arrows 7-7 in Figure 2, illustrating knob and cable movement to effectuate lateral movement of the operating capsule apparatus reactive to the longitudinal axis of the operating capsule.

Figures 8 and 9 are top views of operating capsule apparatus illustrating left and right movement of the operating capsule respecting the longitudinal axis of the operating capsule.

Figure 10 is a sectional view of operating control module apparatus taken at lines and arrows 7-7 in Figure 2, illustrating knob and cable movement to effectuate vertical movement of the operating capsule apparatus relative to the longitudinal axis of the capsule.

Figures 11 and 12 are side views of operating capsule apparatus illustrating vertical movement of the operating capsule relative to the longitudinal axis of the operating capsule.

Figure 13 is a sectional view of operating control module apparatus taken at lines and arrows 7-7 in Figure 2, illustrating knob and cable movement to effectuate opening and closing of the operating capsule.

Figure 14 is a vertical section, taken at lines and arrows 14-14 in Figure 9, of operating capsule apparatus manifesting aspects of the invention with the operating capsule illustrated in its closed position.

Figure 15 is partially sectioned side view of the operating capsule apparatus manifesting aspects of the invention with the operating capsule illustrated in an open position.

Figure 16 is a partially sectioned broken view, taken looking from left to right in Figures 10 and 13,

-10-

of operating control module apparatus manifesting aspects of the invention.

Figure 17 is a view similar to Figure 16 but showing certain parts of the operating control module in
5 different positions.

Figure 18 is an isometric partially broken view of the operating capsule apparatus manifesting aspects of the invention with the capsule shown open to reveal parts of the tissue stapling and cutting apparatus.

10 Figure 19 is an isometric view of a lip portion of a lower shell of the operating capsule apparatus manifesting aspects of the invention shown in Figure 18, further revealing parts of the tissue stapling and cutting apparatus.

15 Figure 20 is a side elevation of a suture support member manifesting aspects of the invention.

Figure 21 is a top view of the suture support member illustrated in Figure 20.

20 Figure 22 is a front view of the suture support member illustrated in Figures 20 and 21, taken looking from left to right in Figure 20.

Figure 23 is an isometric view of the suture support member illustrated in Figures 20, 21 and 22.

25 Figure 24 is a partially broken side elevation of the interior of the lower lip portion of the operating capsule apparatus illustrated in Figure 19.

Figure 25 is a sectional view of the lower lip of the operating capsule illustrated in Figures 18, 19 and 24, taken at lines and arrows 25-25 in Figure 24.

30 Figure 26 is a sectional view of the lower lip of the operating capsule illustrated in Figures 18, 19 and 24, taken at lines and arrows 26-26 in Figure 24.

35 Figure 27 is a partially broken side elevation of operating control apparatus manifesting aspects of the invention, taken from the same side as Figures 16 and 17.

-11-

Figure 28 is a side view of operating capsule apparatus manifesting aspects of the invention with the capsule shown open and with remotely actuatable tissue grabbers illustrated within the operating capsule.

5 Figure 29 is a partially broken isometric view of operating control module apparatus manifesting aspects of the invention illustrating control of certain portions of the operating capsule using control knobs of the operating control module.

10 Figure 30 is an isometric partially broken view of the operating capsule apparatus illustrated in Figures 1B, 2, 8, 9, 11, 12, 14, 15, 18 and 28, illustrating the tissue grabbers and control cables used to effectuate various motions and functions of the operating capsule.

15 Figure 31 is a partially broken isometric view of the operating capsule illustrated in Figures 1B, 2, 8, 9, 11, 12, 14, 15, 18, 28 and 30, showing grasp of malignant, diseased or otherwise undesired tissue to bring that tissue into the operating capsule interior and schematically illustrating tissue stapling and
20 tissue cutting to separate the tissue within the operating capsule from surrounding healthy tissue.

Figure 32 is a schematic side elevation in section of a second embodiment of apparatus for removing
25 malignant or other undesirable tissue from the wall of a lumen (such as the colon), while within the lumen (such as the colon), by removing a cylindrical segment of the luminal wall which includes such malignant or other undesirable tissue, manifesting aspects of the
30 invention.

In the drawings and in the following text reference numerals used in the drawings identify correspondingly numbered structure described in the text.

35 **Description of the Preferred Embodiments
and Best Mode Known for Practicing the Invention**

-12-

Referring to the drawings in general and to Figures 1A and 1B in particular, apparatus for removing malignant, other diseased or otherwise undesirable tissue from a lumen wall, such as the colon wall, while within a lumen, such as the colon, is designated generally 10 and includes a longitudinally elongated operating capsule designated generally 12, an operating control module designated generally 14 and a cable carrying flexible tubular member, designated generally 16, connecting operating capsule 12 and operator control module 14. Operating capsule 12 preferably includes an outer shell 18 having a preferably curved end 20 at one longitudinal extremity thereof which is also a longitudinal extremity of apparatus 10.

Figure 2 illustrates the manner in which a preferred embodiment of the apparatus from removing malignant, other diseased or otherwise undesirable tissue from a lumen wall, which apparatus is designated generally 10 and is illustrated in Figures 1A and 1B, is preferably used in conjunction with an endoscope where the endoscope is designated generally 216 and has a tip extremity 218 at the end of a flexible tubular transmission means 220. The transmission means 220 fits within and passes through a passageway extending axially the length of the longitudinally elongated operating capsule 12 and the cable carrying flexible tubular member 16 of apparatus 10.

Endoscope 216 further includes a control segment designated generally 222 which is generally conical in configuration, as illustrated in Figure 2. Control segment 222 includes an eyepiece 224, an input light source 226, a motion control disk 228, a motion control knob 230, an access port 232 and a push button control 234.

Tip extremity 218 of flexible tubular transmission means 220 of endoscope 216 includes a light provided by

-13-

fiberoptics extending through flexible tubular transmission means 220 and receiving light from input light source 226. Tip extremity 218 of flexible tubular transmission means 220 is maneuverable by the physician or other attending health care professional by rotation of motion control disk 228 and motion control knob 230 and by axial advancement of endoscope 216 and particularly flexible tubular transmission means 220 thereof. Motion control disk 228 has curved edge cut-out portions removed therefrom to facilitate gripping of disk 228 by the fingers.

A physician or other attending health care professional can inspect the colon by inserting tip extremity 218 into the colon through the rectum and thereafter guiding tip extremity 218 up the colon, as flexible tubular transmission means 220 is further advanced into the colon, by watching through eyepiece 224. Fiberoptics connect eye piece 224 with tip extremity 218 thereby providing the physician or other attending health care professional with a view ahead as flexible tubular transmission means 220 of endoscope 216 is advanced along the tortuous path defined by the colon. Optionally, the endoscope may have the viewing fiberoptics connected to a television camera, instead of or in addition to eye piece 224, thereby permitting the physician or other attending health care professional to view the interior of the colon (as seen from tip extremity 218) on a high resolution television screen.

Endoscope 216 may further optionally be equipped with small heaters at tip extremity 218 to perform cauterizing functions as desired. Additionally, the physician or other attending health care professional can utilize access port 232 to insert a catheter or other flexible probe to pass through the length of flexible tubular transmission means 220 and out of tip

-14-

extremity 218, to perform desired surgical or pathological procedures.

Further referring to Figures 4 and 5, flexible tubular transmission means 220 of endoscope 216 is illustrated in transverse or axial section in Figure 4. Endoscope 216 has with four axial passageways within and extending through flexible tubular transmission means 220; the passageways have been numbered 236 with subscripts 1 through 4 identifying respective ones of the four passageways. Typically, one passageway 236 carries a fiberoptic strand providing light at tip extremity 218, a second passageway 236 carries a fiberoptic strand for transmitting the image seen at tip 218 to eye piece 224 and/or a suitable television display device, a third passageway 236 carries control cables or other control mechanisms actuated by motion control disk 228 and motion control knob 230 while a fourth passageway 236 is empty, permitting the physician or other attending health care professional to use a variety of devices insertable into such fourth passageway via access port 232. The fiberoptics, control mechanisms and the light transmission means resident within passageways 236 have not been illustrated in the drawings, to avoid drawing clutter.

Flexible tubular transmission means 220 is preferably a flexible foam-like or other material, other than for the presence of passageways 236 is solid and is surrounded by a flexible rubber, vinyl or other flexible smooth material sheath so that flexible tubular transmission means 220 may be inserted into the colon via the rectum without damage to rectal tissues.

Flexible tubular transmission means 220 when in place within apparatus 10 is preferably but not necessarily coaxial and concentric with cable carrying flexible tubular member 16, as generally illustrated in Figures 4 and 5.

-15-

Referring still to Figure 2 and additionally to Figures 8, 9, 11, 12, 14, 15, 18, 28 and 30, outer shell 18 of operating capsule 12 includes an upper shell portion 22 and a lower shell portion 24 which are
5 connected by hinges or other suitable hinging means, which are not visible in Figure 1 but are shown schematically in Figure 15 and are designated generally 44.

Upper and lower shell portions 22, 24 are
10 longitudinally aligned and movable relative to one another about hinges 44 or other hinging means so that upper and lower shell portions 22, 24 can move, thereby to open shell 18, by relative rotation of upper and lower shell portions 22, 24 about hinges 44.

Upper and lower shell portions 22, 24 have
15 respective lip portions 26, 28 which are preferably spaced from one another when outer shell 18 is closed and upper and lower shell portions 22, 24 are proximate one another, as shown in Figure 14.

Referring to Figure 1 and specifically to Figure 1A and also to Figures 7, 10, 13, 16, 17, 27 and 29, operator control module 14 includes a base 30, a handle 32, a housing 34 supported above base 30 by handle 32, a trigger 36 and a plurality of control knobs, described
20 in more detail below, facilitating remote operator control of operating capsule 12. These control knobs include an outer shell open/close control knob 38, an operating capsule left/right control knob 40 and an operating capsule up/down control knob 42, all
25 illustrated in Figure 1A. Control knobs 38, 40 and 42 are mounted on respective shafts, which are largely hidden and hence are not numbered in Figure 1A, for rotation of respective pulleys to actuate cables wrapped thereabout within housing 34. Various ones of control
30 knobs 38, 40 and 42 are also illustrated in one or more of drawing Figures 7, 10, 13, 16, 17, 27 and 29.

-16-

Apparatus 10 for removing malignant, other diseased or otherwise undesirable tissue from a lumen wall, such as the colon wall, while within a lumen such as the colon is designed so that operating capsule 12 may be inserted into the colon through the rectum while operating control module 14 remains outside the patient's body but is connected to operating capsule 12 remotely by cable carrying flexible tubular member 16.

As best shown in Figures 16 and 17, operating control module 14 further includes a helically coiling spring steel member 54 which biases pivotally movable trigger 36 against movement in the direction to pull on a first cable 48 which is connected to pulley 52 and wraps about pulley 52 upon rotation thereof. First cable 48 extends through cable carrying flexible tubular member 16 into operating capsule 12 to connect with a ramp-knife assembly 50, which performs tissue fastening staple advancement and tissue cutting. Ramp-knife assembly 50 is desirably unitary in that the assembly is fabricated from a plastic-metal assembly or from a single piece of metal. Ramp-knife assembly 50 is illustrated in Figures 17 and 18 and is pulled by cable 48 along a path defined by lip portion 28 of lower shell portion 24.

Referring specifically to Figures 16 and 17, trigger 36 is connected to pulley 52 via a piece of helically coiling spring steel 54 defining a helical leaf-like spring. When actuating the tissue fastening staple advancement and tissue cutting means, specifically ramp-knife assembly 50, the operator pulls on trigger 36, pivotally moving trigger 36 about a pivotal mounting point 37 from the position illustrated in Figure 16 towards the position illustrated in Figure 17. As the operator pulls on trigger 36, helical coiling spring steel member 54 extends and a portion of helical coiling spring steel member 54 is pulled from a

-17-

position of rest, where it is wrapped about a cylindrical shoulder portion 58 of pulley 52, thereby rotating pulley 52 in the direction illustrated by arrow A in Figure 17. This action draws first cable 48 in the direction illustrated by indicator arrow A₁ in Figure 17.

Drawing first cable 48 in this direction causes the remaining end of cable 48, which is connected to ramp-knife assembly 50 within operating capsule 12 as illustrated in Figure 24, to pull ramp-knife assembly 50 along and within lip portion 28 of lower shell portion 24. If the operator pulls trigger 36 through the maximum angular range of travel for trigger 36, from the position illustrated in Figure 16 completely to the position illustrated in Figure 17, ramp-knife assembly 50 moves from the position illustrated in Figure 18, along the entire curved and then straight length of lip portion 28, to the position illustrated in Figure 19.

Travel of ramp-knife assembly 50 is limited by contact of the leading edge of ramp-knife assembly 50, which leading edge is 300 in the drawings, with an upstanding portion of lower lip 28, as illustrated in Figure 19. Hence, once the operator has pulled trigger 36 through its maximum angular range of travel, the operator will sense through feel that trigger 36 cannot be further pulled due to the contact of the leading edge of the knife-ramp assembly with upstanding support member 300 illustrated in Figure 19.

It is not necessary that trigger 36 always be moved by the operator through its entire range of angular and linear travel to thereby pull ramp-knife assembly along the entire range of travel along lip 28. The physician or other attending health professional controlling trigger 36 may choose to advance ramp-knife assembly only along the curved portion of lip 28 illustrated in Figures 17 and 18. For example, the invention may be used to remove tissue encountered by the operating

-18-

capsule in a head-on fashion, when moving in the direction indicated by arrow B in Figure 18. Alternatively, if a large mass of tissue is to be removed, where the tissue drawn into operating capsule 12 overlies the entirety of lip portion 28, the physician or other attending health professional pulls trigger 36 through its full range of angular motion thereby to staple and cut tissue along the entire length of lip portion 28.

10 As illustrated in Figures 16, 17, 18 and 30, first cable 48 is preferably of the type including an inner strand housed within an outer sheath where the inner strand is preferably solid. Whether the inner strand is solid or braided, the inner strand is a high tensile strength material and is moveable axially respecting the outer sheath. The inner strand of first cable 48 is denoted 48_i in the drawings while the outer sheath of first cable 48 is denoted 48_o. Inner strand 48_i and outer sheath 48_o have not been separately numbered in all of the drawings to avoid excessive drawing clutter.

Referring to Figures 3, 4, 5 and 6, cable carrying flexible tubular member 16, through which first cable 48 connects trigger 36 with ramp-knife assembly 50, includes an outer preferably cylindrical sheath 60, a hollow inner preferably cylindrical sheath 62, which is preferably but not necessarily concentric with outer sheath 60, and a plurality of preferably truncated or frusto-conical disks between outer sheath 60 and inner sheath 62. The individual conical disks are designated generally 64 in the drawings. Disks 64 are best illustrated in Figures 3, 4, 5 and 6. Each individual conical disk 64 preferably includes a hollow central conical portion 66 and an annular flange 68 at the base of conical portion 66. Each disk 64 has an axial inner aperture 74 preferably at the center of conical portion

-19-

66. Inner sheath 62 resides within axial inner apertures 74 of disks 64.

Each disk 64 preferably further has a convex conical exterior surface 70 formed on central conical portion 66. Each disk 64 also preferably includes a preferably concave conical surface 72 formed on the interior of central conical portion 66 and a preferably convex conical surface 70 formed on the exterior of central conical portion 66. Concave conical interior surface 72 is shaped for sliding, substantially complementally facing contact with convex conical exterior surface 70 of an axially immediately adjacent disk 64. This arrangement, facilitating movable, sliding and twisting contact between axially adjacent disks 64, is best illustrated in Figures 5 and 6.

The generally conical geometry of the portions of disks 64 extending from annular flanges 68 serves to maintain adjacent disks generally in coaxial and aligned position but nevertheless permits the column of disks 64 residing within outer cylindrical sheath 60 of flexible member 16 to twist and turn in order to follow what may be a very tortuous path defined by a body lumen as operating capsule 12 travels axially within that lumen. The arrangement of the concave conical interior surface 72 in substantially complementally facing contact with convex conical exterior surface 70 of the immediately adjacent disk provides sufficient rigidity that flexible member 16 cannot be sharply bent. This is important in order that flexible member 16 may keep cables, such as first cable 48 via which the operator at control module 14 controls operating capsule 12, from bending. If those cables bend and develop kinks, control over operating capsule 12 may be lost. Loss of control over operating capsule 12 could be catastrophic, requiring withdrawal of the apparatus 10 from the patient prior to completion of the surgical procedure of interest.

-20-

When cable carrying flexible tubular member 16 is bent to an extreme, interference between flanges 68 of adjacent disks 64 prevents further bending of tubular member 16 thereby minimizing the likelihood of any twisting of the control cables carried by and passing through cable carrying flexible tubular member 16.

The arrangement of disks 64 prevents self-collapse of cable carrying flexible tubular member 16 and also prevents telescoping of flexible tubular member 16. Disks 64 permits flexible tubular member 16 to transmit axial driving force, which is required to be applied by the physician or attending health care professional to move operating capsule 12 and cable carrying flexible tubular member 16 axially along the colon. Disks 64 facilitate transmission of that driving force axially, even though the axis of the colon, and therefore the path being followed by operating capsule 12 and cable carrying flexible tubular member 16, is curvilinear. As cable carrying flexible tubular member advances operating capsule 12 along the axis of the colon, the axis orientation is continuously changing as is the position or positions of curvature of flexible tubular member 16. The arrangement of conical disks 64 within member 16 provides the requisite ability to axially transmit the necessary driving force as flexible tubular member 16 changes position and orientation while advancing along the colon axis.

Referring to Figures 1A, 7, 8 and 9, left and right control of operating capsule 12 is effectuated by rotation of capsule left/right control knob 40. Capsule left/right control knob 40 is rotatably mounted on a shaft 112, which in turn is rotatably mounted in housing 34 of operating control module 14 and has a pulley 114 fixedly connected thereto as illustrated in Figure 7. A cable 116, referred to as a "second" cable to distinguish cable 116 from "first" cable 48, is wrapped

-21-

about pulley 114; respective ends of second cable 116 extend from operating control module 14 through cable carrying flexible tubular member 16 to operating capsule 12. Rotation of left/right control knob 40 in
5 respective directions results in operating capsule 12 moving to the right and left relative to the longitudinal axis thereof as illustrated respectively in Figures 8 and 9. In Figures 8 and 9 the referenced longitudinal axis is denoted by hash marks and movement
10 of operating capsule 12 to the right and left with respect thereto is denoted by arrows R and L in Figures 8 and 9 respectively.

Referring to Figure 15, operating capsule 12 has an openable portion, defined by upper shell portion 22 and
15 lower shell portion 24, and a transition portion denoted generally 118. Transition portion 118 is not openable; transition portion 118 serves to reduce the cross-sectional size of apparatus 10 from the cross-sectional size of operating capsule 12 in the area of upper and
20 lower shell portions 22, 24 down to a smaller cross-section as defined by the cross-section of cable carrying flexible tubular member 16.

Transition portion 118 includes a bulkhead 120 and an outer skin or shell portion 122 which is generally
25 hollow as illustrated in Figure 15.

Bulkhead 120 preferably provides a solid support and mounting area for the mechanism used to move upper shell portion 22 of capsule 12 as upper shell portion 22 is rotated relative to lower shell portion 24 thereby to
30 open operating capsule 12. Additionally, bulkhead 120 provides support for removable lower lip portion 28. Furthermore, bulkhead 120 receives respective ends of second cable 116, specifically respective ends of inner strand 116₁ of second cable 116. These respective ends
35 of second cable 116 are preferably connected to bulkhead 120 at the lateral extremities of bulkhead 120 at a

-22-

position on the vertical midpoint of bulkhead 120. Second cables 116 preferably enter transition portion 118 through respective appropriate slots in a flange 124 located at the axially opposite end of transition
5 portion 118 from bulkhead 120. Flange 124 is illustrated in Figure 30.

Respective outer strands 116_o of second cable 116 preferably reside within respective slots formed in flange 124 on diametrically opposite sides of flange
10 124, at the horizontal axis thereof. These respective ends of outer strands 116_o of second cable 116 are illustrated in Figure 30. The tie-ins of inner strands 116_i to bulkhead 120 have not been illustrated in the drawings to avoid drawing clutter.

Respective ends of second cable 116 passing through cable carrying flexible tubular member 16 reside within diametrically opposed respective slots designated 126, 126' in annular flanges 68 of disks 64 as illustrated in
15 Figure 4. Second cable 116 enters cable carrying flexible tubular member 16 from housing 34 of control module 14 via a flange 128, illustrated in Figure 7, which corresponds generally to flange 124 located at the opposite end of cable carrying flexible tubular member
20 16 and illustrated in Figures 17 and 24.

Referring generally to Figures 10, 11 and 12, up/down control of operating capsule 12 is effectuated generally by rotation of capsule up/down control knob 42 forming a part of operating control module 14. Capsule
25 up/down control knob 42 is rotatably mounted on a shaft 130 which is rotatably mounted for rotation relative to and within housing 34 of control module 14. Fixedly connected to shaft 130 is a pulley 132 about which is wrapped a third cable 134. Similarly, to first and
30 second cables 48, 116, third cable 134 desirably has a solid inner strand denoted with the subscript "I" and an outer sheath denoted with the subscript "O".
35

-23-

Respective portions of third cable 134 extend through cable carrying flexible tubular member 16 and into transition portion 118 where respective ends of third cable 134, specifically respective ends of inner strand 134₁, are fixedly connected to bulkhead 120. These respective ends of third cable 134 are fixedly connected to bulkhead 120 at the top and bottom extremities of a vertical axis of operating capsule 12. These connections are not illustrated in the drawings to avoid drawing clutter.

Similarly to second cable 116 and first cable 48, third cable 134 enters cable carrying flexible tubular member 16 by passing through respective apertures in flange 128 and resides within slots 136, 136' in flanges 68 of disks 64, as third cable 134 extends the length of cable carrying flexible tubular member 16. This arrangement of third cable 134 passing through apertures in flange 128 is illustrated in Figure 29. The arrangement of third cable 134 in slots 136, 136' in flanges 68 of disks 64 is illustrated in Figure 4. The arrangement of third cable 134 in respective slots in flange 124, where third cable 134 enters transition portion 118, is illustrated in Figure 30.

Rotation of capsule up/down control knob 42 in respective directions denoted by respective unnumbered arrows in Figure 10 results in movement of operating capsule 12 up and down with respect to a longitudinal reference axis as illustrated by arrows U and D in Figures 10 and 11 respectively, as cable 134 pulls in respective directions on bulkhead 120 due to rotation of pulley 132.

Capsule left/right control knob 40 and its associated pulley shaft and cable have not been numbered in Figure 10 to avoid drawing clutter. Similarly, operating capsule up/down control knob 42, shaft 130,

-24-

and pulley 132 and associated third cable 134 have not been illustrated in Figure 7 to avoid drawing clutter.

Referring to Figure 13, opening and closing of operating capsule 12 is preferably effectuated by rotation of capsule open/close control knob 38 by the operator. Capsule open/close control knob 38 is mounted on a shaft 138 which is rotatably journaled within and extends into the interior of housing 34. A bevel gear 140 is fixedly mounted on shaft 138 at the end thereof opposite from capsule open/close control knob 38 within housing 34.

A pulley 142 is mounted coaxially with pulleys 114 and 132 but is freely rotatable independently thereof. Pulley 142 has a bevel gear surface 144 formed on one side thereof. The teeth of bevel gear surface 144 mesh with the teeth of bevel gear 140. Accordingly, rotation of capsule open/close control knob 38 and consequent rotation of bevel gear 140 serves to rotatably drive pulley 142 about its axis of rotation. A fourth cable 146 is wrapped about pulley 142 so that upon rotation of pulley 142, one of the two portions of fourth cable 146 extending therefrom is advanced off of pulley 142 while the remaining portion of fourth cable 146 is retracted by being wound onto pulley 142.

Fourth cable 146 extends from operating control module 14 through cable carrying flexible tubular member 16 and into transition portion 118.

Referring to Figures 13 and 14, a threaded shaft 148 is preferably rotatably mounted on a pedestal block 150 which is fixedly connected to bulkhead 120. A drive pulley 152 is fixedly mounted at one end of threaded rotatable shaft 148 and is rotatable unitarily therewith. Fourth cable 146 is preferably wrapped about drive pulley 152 as illustrated in Figures 13 and 14.

Advancement of one portion of fourth cable 146 and concomitant retraction of the remaining portion of

-25-

fourth cable 146 due to rotation of pulley 142 responsively to rotation of capsule open/close control knob 38 causes rotation of threaded rotatable shaft 148.

5 A nut 154 threadedly engages shaft 148 and is movable freely therealong in response to rotation of shaft 148. Fixedly connected to nut 154 is an arm 156. Arm 156 extends generally horizontally from nut 154, towards the side of operating capsule 12 where lip portions 26, 28 are located; this is the side of operating capsule 12 which opens upon rotation of upper
10 shell portion 22 relative to lower shell portion 24.

A pin 158 preferably extends generally longitudinally parallel with the axis of operating capsule 12 and cable carrying flexible tubular member
15 16, from arm 156 towards the curved axial and longitudinal extremity of operating capsule 12. Pin 158 has a shaft portion and a head portion, neither of which are numbered in the drawings. The head portion of pin 158 is mounted in a lift arm 160 connected to upper
20 shell 22 and forming a portion thereof. Pin 158 passes through a slot or other opening in bulkhead 120 to provide the connection between arm 156 and lift arm 160.

As drive pulley 152 rotates threaded shaft 148 in a given direction, since shaft 148 is axially immovable
25 this causes nut 154 to ride up or down shaft 148, depending on the direction of rotation of shaft 148. As nut 154 rides up shaft 148 when the apparatus is positioned as illustrated in the drawings, such rotation of shaft 148 causes upper shell portion 22 to rotate
30 upwardly relative to lower shell portion 24 thereby opening operating capsule 12 as illustrated generally Figure 18. Rotation of threaded shaft 148 in the opposite direction due to advancement of the remaining portion of fourth cable 146 causes nut 154 to ride
35 downwardly along threaded rotatable shaft 148, causing upper shell portion 22 to rotate towards lower shell

-26-

portion 24 thereby closing operating capsule 12 in response to rotation of capsule open/close control knob 38.

5 While the operating capsule open/close mechanism has been illustrated utilizing motion of a nut along a threaded shaft to effectuate the opening and closing, it is within the purview of the invention to provide one or more small electric or hydraulic motors to perform the opening and closing function. When such motors are
10 used, gears or pistons on any other appropriate drive mechanism or means may be used to open and close the operating capsule.

Referring generally to Figures 18, 19, 24 and 26, ramp-knife assembly 50 is fabricated with a knife
15 portion 76 having an inclined, leading tissue cutting edge 78. Ramp-knife assembly 50 further includes a horizontal base portion 80 and an inclined staple advancing ramp portion 82. First cable 48 is removably affixed to ramp-knife assembly 50, preferably to the
20 bottom surface of horizontal base portion 80 at a position thereon immediately underneath inclined leading tissue cutting edge 78 of knife portion 76, as illustrated in Figures 18 and 24 through 26. First cable 48 is preferably retained in position and
25 removably affixed to ramp-knife assembly 50 by a spring-clip 302 which is affixed to the lower surface of ramp-knife assembly 50 as best illustrated in Figures 25 and 26. Spring-clip 302 retains an end of first cable 48 in engagement therewith; first end of cable 48 preferably
30 is equipped with a knob 304, illustrated in Figure 24 which interacts with spring-clip 302 so that when first cable 48 is advanced in a direction to the right in Figure 24, interaction between spring-clip 302 and knob 304 forces ramp-knife assembly 50 to the right in figure
35 24. This arrangement with spring-clip 302 holding first cable 48 in place permits reuse of cable 48 and the

-27-

upper portion of capsule 12 once a suturing or stapling function has been performed and the staples have been used to secure tissue together and are no longer resident within lower lip 28 of capsule 12.

5 Preferably lower shell portion 24 of operating capsule 12 is fabricated of plastic, metal or some other suitably rigid material so that lower shell portion 24 has a hollow interior. Most preferably, lower shell portion 24 of operating capsule 12 is plastic as is lip
10 portion 28. This hollow interior, which is visible via the cut-aways in Figures 18 and 19 and in the sectional views of Figures 25 and 26, defines the curved and then straight path traveled by ramp-knife assembly 50 as ramp-knife assembly 50 is advanced and performs its
15 staple advancing (for tissue fastening) and tissue cutting functions.

Most preferably lip portion 28 of lower shell 24 is constructed to be easily snapped into place and removed from the remainder of lower shell portion 24, with lip
20 portion 28 preferably being constructed as illustrated in Figure 19. Suitable snap-in and snap-out fixtures and geometry may be provided at respective ends of lip portion 28; one such snap-in and snap-out structure is denoted 84 in Figure 19. The snap-in and snap-out
25 construction of lip portion 28 is preferred in order that once staples have been placed into tissue and a given surgical procedure has been completed, a spent lip portion 28 may be removed from lower shell 24 and replaced with a fresh lip portion 28 loaded with
30 suitable staples in order that operating capsule 12 may be reused numerous times to minimize costs associated with performance of such surgical procedures.

Respecting materials for operating capsule 12, so long as the materials may be adequately sterilized for
35 reuse of operating capsule 12, any suitable plastic,

-28-

metal or other suitable rigid or semi-rigid material or materials may be used.

Lip 28 has a longitudinally extending slot running along the lower inside portion thereof. Due to the positioning of lip 28 in Figure 19, that slot cannot be seen in Figure 19 but is clearly shown in the sectional views of Figure 26. The slot, which is designated generally by indicator number 186 in Figure 26, is defined by a lower extremity 188 of an inner wall 96 of lower lip 28 and a horizontal bottom surface 190 of lower lip 28.

An inner lateral extremity of horizontal base portion 80 of ramp-knife assembly 50, which supports an upstanding knife support 192 for knife portion 76 of ramp-knife assembly 50, extends laterally outwardly through and from that slot, inwardly into the interior of the capsule. This construction is illustrated in Figures 25 and 26. Additionally, knife support 192, knife portion 76 and specifically knife leading cutting edge 78 thereof extend above the upper extremity of lip assembly 28; the upper extremity is denoted 86 in Figures 19 and 25. Upper extremity 86 is defined by a preferably planar surface 88, best illustrated in Figure 23, which may be horizontal or may be slightly inwardly inclined from the outer portion of lip 28 to the inner portion. In either case, inclined knife leading cutting edge 78 of knife portion 76 extends above the upper inner edge of lip 28 defined by upper extremity 86. Hence, any tissue extending across planar upper surface 88 past edge 86 and into the interior of capsule 12 is cut by inclined leading tissue cutting edge 78 of knife 76 as ramp-knife assembly 50 traverses the curved and then straight path defined by the hollow interior of lower lip 28. While the apparatus in the preferred embodiment has been illustrated with the opening between upper and lower lips 26, 28 of capsule 12 being

-29-

generally at the horizontal mid-point of capsule 12, this is not required. The position at which upper and lower shell portions 22, 24 of capsule 12 separate to provide the two facing lips where the tissue suturing and cutting function is performed does not have to be at the horizontal mid-point of capsule 12 and, indeed, does not even have to be a symmetrical position of closure respecting the longitudinal axis of capsule 12.

The preferred configuration of ramp-knife assembly 50 illustrated in Figures 18 and 19 and shown in section in Figures 25 and 26 lends stability to the assembly. Specifically, working surfaces of ramp-knife assembly 50 are desirably at least generally planar; exemplary of these are outboard surface 90 of suture advancing ramp, the bottom surface of ramp-knife assembly 50, namely the downwardly facing surface of horizontal portion 80 of ramp-knife assembly 50 which is not numbered in Figures 19, 25 or 26, the exterior surfaces of knife support portion 192 and outboard (with respect to operating capsule 12 as a whole) surface 92 of knife portion 76 of ramp-knife assembly 50. Outboard surface 92 rides in complementary facing contact with an inwardly (with respect to operating capsule 12 considered as a whole) facing surface 94 of inner wall portion 96 of lower lip 28, as illustrated in Figure 19.

Ramp-knife assembly 50 may be fabricated with two separate portions of outwardly facing surface 90, a forward portion 90_F and a rearward portion 90_R , where surfaces 90_F and 90_R may be at slight angles to one another about a vertical boundary therebetween denoted 98 in Figure 19. This geometry may be desirable if the longitudinal length of ramp-knife assembly 50, denoted L_1 in Figure 19, is relatively large with respect to the radius of curvature of the curved end of lower lip 28 and hence the radius of the resultantly curved portion of the path along which ramp-knife assembly 50 travels

-30-

as it performs its tissue fastening staple advancement and tissue cutting function; that path is preferably defined by the hollow interior of lower lip 28.

In the preferred embodiment of the apparatus of the invention, ramp-knife assembly 50 is preferably fabricated of a single piece of flexible material, preferably plastic, with the material being flexible enough to permit the ramp-knife assembly to slide easily around the curved portion of the path along which ramp-knife assembly travels as it performs its tissue fastening staple advancement and tissue cutting functions. Of course, the knife portion is preferably metal to provide an extremely sharp edge so that the tissue cutting results in a clean, well defined cut.

Sliding, substantially complementally facing contact between surfaces 90_F and 90_R and the inwardly facing surface 100 of outer wall 102 of lower lip 28, as illustrated in Figures 26, provides further stability as ramp-knife assembly travels within lower lip 28.

The tissue fastening staple apparatus aspects of the invention are best illustrated in Figures 18 through 26. Specifically referring to Figure 20, individual staples 104 are preferably formed of extremely fine solid stainless steel wire, titanium or other suitable permanent or dissolvable tissue fastening stapling/suturing material. Each staple 104 is preferably initially formed of three straight portions, specifically two stapling fingers denoted 262 and 262' connected by a stapling base designated 264. Stapling fingers 262, 262' are preferably initially parallel to one another and preferably are of the same length. Stapling fingers 262, 262' extend from stapling base 264 preferably at substantially right angles to stapling base 264. Each staple 104 is preferably mounted in a respective staple support block of a staple support member.

-31-

Referring generally to Figures 20 through 23, a staple support member is designated generally 166 and includes two staple support blocks, which are designated 168, 168' respectively, connected integrally together by a generally trapezoidally configured solid adjoining member 170. Preferably, each staple support member 166 is of integral construction such that respective staple support blocks 168, 168' and adjoining member 170 are a unitary piece of preferably injection molded or compression molded plastic.

As apparent from Figures 20 through 23, staple support blocks 168, 168' of each staple support member 166 are preferably of rectangular solid configuration and are longitudinally offset one from another, as illustrated. Each staple support block 168, 168' preferably has a longitudinal groove 172 extending the longitudinal length of the staple support block, in an upwardly facing preferably planar surface of the staple support block 168, 168'. Longitudinal groove 172 is sized and has a shape respecting stapling base 164 so as to retain stapling base 164 in a releasable manner. Once the tissue fastening by stapling function has been performed and the operating capsule is to be removed from the body, staples 104 pull easily out of longitudinal grooves 172 and remain with the stapled tissue which the staples have penetrated, thereby securing the stapled tissue together.

While staple support blocks 168 preferably are generally rectangular solid in configuration, adjoining member 170 preferably has an inclined lower surface designated generally 174.

A plurality of staple support members 166 are preferably housed within lower lip 28 of lower shell portion 24; an exemplary group of staple support members 166 is illustrated in Figure 24. Each staple support block 168, 168' of a staple support member 166 is

-32-

substantially vertically aligned with a respective preferably rectangular aperture 108 formed in planar upper surface 88 of lip 28, as illustrated in Figure 23. Apertures 108 are preferably arranged in two parallel rows extending along the curved and then straight path traveled by ramp-knife assembly 50 as such path is defined by lower lip 28. Apertures in the inner row are denoted with a subscript "I" while apertures 108 in the outer row are denoted with the subscript "O". Spacing of apertures 108_I and 108_O and specifically the longitudinal offset of apertures 108_I and 108_O corresponds to the longitudinal offset of respective staple support blocks 168, 168' of a single staple support member 166, with such offsets being best illustrated in the isometric view provided by Figure 23.

Similar nomenclature is used to denote inner and outer staple support blocks 168 which are in registry with inner and outer apertures 108. Outer staple support blocks, in the outer row and which are aligned with apertures 108_O, are denoted 168_O. Staple support blocks which are in the inner row and are in registry with apertures 108_I are denoted 168_I. This arrangement is illustrated in Figure 23.

Referring specifically to Figure 24, a section of lip portion 28 from lower shell portion 24 is depicted with the outer wall 102 substantially broken away to reveal the arrangement of staple support members 166 and the manner in which staple support members 166 are upwardly advanced by ramp-knife assembly 50 to effectuate tissue securement by stapling.

In Figure 24 inner wall 96 of lower lip 28 has a surface 106 which is facing inwardly respecting the interior of lower lip 28 but faces outwardly respecting operating capsule 12 taken as a whole.

Surface 106 has a series of vertically extending channels formed therein, which are adapted for sliding

-33-

receipt of a staple support block 168 of a staple support member 166. Only one of these channels, which has been designated 176 in Figure 24, has been illustrated in Figure 24, to aid drawing clarity. There is preferably one channel 176 for each staple support member 166.

Each channel 176 is defined by a rib 310, one of which has been illustrated in Figure 23, extending transversely outwardly from surface 106, in a direction perpendicular to the plane of the paper in Figure 24, and which extend along the entire vertical height of surface 106 in Figure 24. Respective vertically extending longitudinally facing surfaces of two adjacent ones of these ribs are illustrated in dotted lines in Figure 24 and are denoted 180; surface 180 of rib 310 appears as a line in Figure 23.

At the end of each rib remote from surface 106 is a web which is parallel with surface 106. Two such webs have been illustrated in Figure 24 and are designated generally 178; one web 178 is shown in Figure 23 and has been broken away to illustrate the relationship between web 178 and a suture support block 168' and specifically an oppositely longitudinally facing surface 181 thereof. The two dotted lines which denote the longitudinally facing transversely extending surfaces of rib 310, which surfaces are hidden by webs 178 in Figure 24, are denoted 180 in Figure 24. A longitudinally facing surface 180 of a rib 310 is longitudinally spaced from an immediately adjacent rib 310 a distance just slightly greater than the longitudinal length of a suture support block 168, as denoted by dimensional arrow L in Figure 23. Hence, an inboard suture support block 168 of a suture support member 166 is slidably vertically movable in a groove defined by two adjacent ribs 310.

Webs 178 overlies longitudinally facing surfaces 180 of the ribs 310. Ribs 310 extend transversely

-34-

outwardly respecting surface 96 a distance slightly greater than the thickness, in the transverse direction, of suture support block 168, which thickness is denoted by dimension T in Figure 23. Since webs 178 overlie
5 longitudinally facing surfaces 180 and since the ribs are slightly longer than the thickness of a suture support block 168, webs 178 serve to retain a suture support block in vertically sliding disposition within the groove defined by surface 106, rib 310 and web 178.

10 A portion of upper surface of lip 28 between inner apertures 108_i and outer apertures 108_o defines a stop for suture support members 166 and is designated generally 182 in Figure 23. This strip of preferably plastic material extends longitudinally and interferes
15 with upper surfaces 184 of adjoining members 170 when suture support members 166 are urged upwardly within grooves defined by adjacent ribs 310. Hence, as ramp-knife assembly 50 urges the suture support members 166 vertically upwardly, sutures 104 may protrude through
20 apertures 108 and upper portions of suture support blocks 168_i, 168_o may similarly protrude through corresponding apertures 108_i and 108_o. However, interference between member 170 of suture support member 166 and material strip 182 limits upward travel of the
25 suture support member 166.

The suturing members have been illustrated as staples 104. While staples such as those illustrated as 104 are preferred, any suitable suturing means may be utilized in place of the staples illustrated as 104 in
30 the drawings.

Still referring to Figure 24, a plurality of outer staple support blocks 168_o forming portions of respective staple support members 166 are shown. For drawing clarity, an inner staple support block 168_i has been
35 illustrated in dotted lines for only a single one of the staple support members 166. The staple support block

-35-

168, shown in dotted lines is illustrated in position in the groove defined by ribs 310 whose longitudinally facing surfaces are shown in dotted lines as 180.

5 Prior to contact by ramp-knife assembly 50, which is illustrated in position generally to the left in Figure 24, an individual staple support member 166 is positioned as illustrated by staple support block 168₀ at the extreme right hand side in Figure 24. In such position, stapling fingers 262, 262' are straight and
10 extend at substantially right angles from the upper surface of staple support block 168₀.

As first cable 48 is drawn to the right in Figure 24, first cable 48 pulls ramp-knife assembly 50 to the right in Figure 24. As ramp-knife assembly 50 travels
15 to the right in Figure 24, inclined ramp 82 is positioned directly under area 182 in planar upper surface 88 of lip 28, illustrated in Figures 18, 19 and 23 separating apertures 108₁ from apertures 108₀. Staple support members 166 are positioned with respective
20 staple support blocks 168₁, 168₀ in registry with associated apertures 108₁, 108₀ and hence with each adjoining member 170 of a staple support member aligned with inclined ramp 82. Inclined lower surfaces 174 of adjoining members 170 are preferably inclined at an
25 angle corresponding to that of ramp 82. Hence, as ramp-knife assembly 50 is moved to the right in Figure 24 by first cable 48, inclined ramp 82 contacts inclined lower surfaces 174 of adjoining members 170 and urges staple support members 166, of which adjoining members 170 are
30 parts, vertically upwardly. This progressive vertically upward travel of staple support members 166, due to the horizontal travel of ramp-knife assembly 50, is illustrated in Figure 24.

As travel of ramp-knife assembly 50 to the right in
35 Figure 24 pushes staple support members 166 vertically upwardly, stapling fingers 262, 262' associated

-36-

therewith pass through an aperture 108 with which staple support block 168 carrying staple 104 is in registry and emerge from upper surface 88 of lower lip 28. As ramp-knife 50 continues further to the right in Figure 24, ramp surface 82 continues to urge staple support members 166 vertically upwardly. Stapling fingers 262, 262' encounter anvil surfaces 260 which are formed in upper lip 26 of upper shell portion 22 and are illustrated in Figure 24. As stapling fingers 262, 260' are urged against anvil surfaces 260, stapling fingers 262, 260' bend and curve in a plane defined by the slot-like configuration of anvil surfaces 260. The curvature of stapling fingers 262, 260' in a plane defined by ramp-knife assembly 50 is shown by stapling fingers 262, 262' associated with the staple support block 168₀ at the extreme left hand side of Figure 24. The slot-like configuration of anvil surface 260 in upper lip 26 is illustrated in Figure 26.

When tissue is present between lip portions 26 and 28 and stapling fingers 262, 262' of a staple are driven through such tissue and against anvil surfaces 260, the resulting curvature of stapling fingers 262, 260' illustrated in Figure 24 after passage through the tissue located between lip portions 26 and 28 secures that tissue together. Due to the provision of outer and inner staple support blocks 168₀, 168₁ in registry with respective apertures 108₀ and 108₁, two parallel lines of staples or sutures securing tissue together results. The resulting securement of the tissue is illustrated in the dotted lines in Figure 31.

Further respecting anvil surfaces 260, as illustrated in sectioning in Figure 26, anvil surfaces 260 are offset one from another with the curved downwardly facing portions of anvil surfaces 260 in upper lip 26 causing the resulting curve of stapling fingers 262, 260' in a direction back towards the

-37-

direction in which stapling fingers 262, 260' extend away from stapling base 264 in a manner that staples may be considered a curve back upon themselves, thereby providing excellent securement together of tissue layers positioned between the two lips of the operating capsule.

Referring to Figures 2, 27 and 29 through 31, in the preferred embodiment the apparatus aspect of the invention further includes means for grabbing tissue, specifically lumen wall tissue, and pulling that lumen wall tissue into operating capsule 12 so that the tissue may be cut and sutured thereby removing the diseased or otherwise undesirable tissue from the lumen wall. The tissue grabbers are designated generally 194 in Figure 2. While two such tissue grabbers have been illustrated and are preferred, it is to be understood that only a single tissue grabber may be provided or three or more tissue grabbers may be provided, depending on the size in which the apparatus is constructed and the particular conditions to be treated using the apparatus.

Each tissue grabber 194 preferably includes a handle member designated generally 196 where the handle member includes two preferably integrally formed finger rings 198 and a thumb ring 200. Each tissue grabber 194 further preferably includes a cable 202 where, similarly to the other cables described herein, cable 202 includes inner and outer portions denoted by subscripts "I" and "O" respectively; additionally, each cable 202 further includes an intermediate portion denoted by subscript "M".

Thumb ring 200 is moveable axially relative to handle member 196 and specifically relative to finger rings 198 in the direction indicated by double-ended arrow TR in Figure 2. Finger rings 198 are fixed to intermediate portion 202_M of cable 202. Thumb ring 200 is fixedly connected to inner portion 202_I of cable 200.

-38-

At the ends of cable 202 opposite from finger rings 198 and thumb ring 200, are two spring-loaded alligator clip-type members 204 which are connected to inner portion 202_i of cable 202. Alligator clip-type members 204 have two facing, preferably metallic jaws, each having alligator-type teeth formed by serrations on the facing portion of the jaw. Each jaw is designated 206 in the drawings.

The spring-loading of jaws 206 of alligator clip-type members 204 results in jaws 206 opening as alligator clip-type members 204 are extended out of intermediate portions 202_M of cable 202. Such extension of alligator clip-type members 204 is effectuated by advancing the thumb ring 200 relative to finger rings 198 thereby to advance inner portion 202_i of cable 202 relative to intermediate portion 202_M. Intermediate portion 202_M of cable 202 is preferably fabricated from material having excellent memory characteristics so that the physician or other attending health care professional can effectuate a desired bend of cable 202, specifically intermediate portion 202_M, and such bent intermediate portion 202_M will retain such bend as intermediate 202_M is advanced from or withdrawn into outer portions 202_o of cable 202. The desired bend may be introduced to intermediate portion 202_M manually prior to insertion of operating capsule 12 into the lumen of interest or may be effectuated during the operating procedure by advancing intermediate and inner portions of cable 202 until alligator clip-type members 204 contact one of the rigid interior surfaces of operating capsule 12. Once such contact has been effectuated, continued advancement of intermediate and inner portions 202_M, 202_i of cable 202 will result in these portions of cable 202 bending. Due to the memory characteristic of intermediate portion 202_M, the bend

will remain in intermediate and inner portions 202_M, 202_I of cable 22.

When the physician or other attending professional has positioned operating capsule 12 at the desired location within the lumen and has opened the operating capsule 12 thereby to provide access to the undesirable tissue to be removed, the lumen wall must be grasped and pulled into operating capsule 12 sufficiently far that all of the diseased or otherwise undesirable tissue is within operating capsule 12 prior to the tissue suturing and cutting operation. This tissue pulling is preferably effectuated using tissue grabbers 194. Specifically, the physician or other attending health care professional first preferably advances thumb rings 200 towards finger rings 198. This causes alligator clip-type members 204 at the ends of inner portion 202_I to extend out of intermediate portion 202_M of cable 202 with jaws 206 of alligator members 204 opening due to the spring-loading thereof. The physician or other attending health care professional then moves the alligator clip-type members, with jaws 206 open, into position to grasp the lumen wall tissue at the desired locations. This is accomplished by advancing finger ring 198 and thumb ring 200 together thereby advancing inner portion 202_I and intermediate portion 202_M of cables 202 and alligator clip-type members 204 all unitarily, without moving thumb ring 200 relative to finger ring 198.

Once the open jaws 206 of alligator clip-type members 204 are at the desired positions, the physician or other attending health care professional advances finger ring 198 away from thumb ring 200 while maintaining thumb ring 200 at a fixed position. This movement of finger ring 198, which would be to the left in Figure 2, causes intermediate portion 202_M of cable 202 to close about joined ends of jaws 206 of spring-

-40-

loaded alligator clip-type members 204, thereby closing jaws 206 towards one another and entrapping tissue between the serrated jaws 206.

Once the tissue has been entrapped, the physician
5 or other attending health care professional moves finger ring 198 and thumb ring 200 to the right in Figure 2, without moving finger ring 198 relative to thumb ring 200. This effectively shortens the length of cables 202 which are within operating capsule 12 thereby drawing
10 the gripped tissue into capsule 12. This is illustrated schematically in Figure 31.

Once finger ring 198 and thumb ring 200 have been moved sufficiently far to the right in Figure 2, without any relative motion therebetween, so as to draw the
15 tissue into operating capsule 12 to the desired extent, the physician or other attending health care professional grasps and moves trigger 36 relative to handle 32. This advances ramp-knife assembly 50 along its path to the extent the operator moves trigger 36.

20 Advancement of ramp-knife assembly 50 along the path vertically advances staple support members 166 and staple support blocks 168, driving stapling fingers 262, 262' through tissue resting on planar upper surface 88 of lower lip 28. Due to the configuration of ramp-knife
25 assembly 50 whereby ramp 82 effectuates vertical movement of staple support members 166 with ramp 82 preceding knife portion 76 along the tissue, the tissue is stapled by the action of stapling fingers 262, 262' before being cut by knife portion 76.

30 Referring specifically to Figure 31, luminal wall tissue is designated generally 208. The inner surface of the luminal wall which is a continuous interior surface prior to the tissue stapling and tissue cutting operations, is designated 210 while the outer surface of
35 the luminal wall is designated 212 in Figure 31. The portion of the inner surface 210 of the luminal wall

-41-

tissue which has been grasped and drawn into operating capsule 12 is designated 210'.

In Figure 31, configuration of the luminal wall during the tissue stapling and cutting operation is shown. It is specifically to be noted using the apparatus of the invention and in practicing the methods of the invention, the luminal wall may be drawn entirely into the operating capsule with luminal wall tissue 208 folded upon itself as illustrated so that when the luminal wall tissue has been drawn into the capsule, the exposed upper portion of tissue within operating capsule 12 and the exposed lower (or downwardly facing) portion of tissue within the capsule are both drawn from inner surface 210 of the luminal wall 208. The line denoting the luminal wall tissue folded upon itself is designated 214 in Figure 31.

One major advantage afforded by the apparatus and methods of the invention is that all of the tissue of the luminal wall at a site of interest is drawn into operating capsule 12 prior to the tissue suturing and cutting operation. As a result, once the tissue suturing and cutting operation is complete, an entire section of luminal wall has been removed and is resident within the operating capsule. Where malignant tissue is being removed from a luminal wall, this provides enhanced assurance that resection of the tissue has successfully removed all of the malignant portion from the luminal wall, as contrasted to techniques where only the inner surface of the wall is removed.

As is further apparent from Figure 31, the tissue stapling function occurs prior to the tissue cutting function. This is evident from the fact that the two lines of staples, which have stapled together the folded on itself portion of the luminal wall, are ahead of inclined leading tissue cutting edge 78 of knife portion 76.

-42-

As yet another advantage afforded by the invention, the stapling operation secures together healthy tissue in facing disposition along a site line removed from the line of tissue cutting. This results in faster healing at the wound site. Moreover, the fact that tissue stapling is performed outboard of the locale at which tissue cutting is performed (with the diseased or other undesirable tissue being retained inboard of the tissue cutting function) minimizes probability of contamination of healthy tissue by the resected undesirable and possibly malignant tissue which remains within operating capsule 12.

When apparatus 10 is used in performing procedures in the colon or even the small intestine, typically tip extremity 218 and flexible tubular transmission means 220 of endoscope 216 are fed through apparatus 10 from control module 14 and exit operating capsule 12 via an aperture 238 in upper shell portion 22 of operating capsule 12. Aperture 238 is illustrated in Figures 1B, 8, 9, 18 and 30.

Once endoscope 216 has been threaded through apparatus 10, if a procedure in the colon is being performed, tip extremity 218 and flexible tubular transmission means 220 of endoscope 2 are introduced into the colon via the rectum. The physician or other attending health care professional then proceeds to guide tip portion 218 of endoscope 216 up the colon by manually advancing flexible tubular transmission means 220 into the rectum and controlling left/right and up/down movement of tip portion 218 using motion control disk 228 and motion control knob 230. Once the physician or other attending health care professional has positioned tip portion 218 where the tissue of interest is in view and tip portion 218 is sufficiently close to that tissue that the tissue may be grasped and brought into the interior of operating capsule 12, the

physician or other attending health care professional then advances operating capsule 12 and flexible tubular member 16 along flexible tubular transmission means 220, into the patient's colon via the rectum.

5 The physician guides operating capsule 12 up the colon and along flexible tubular transmission means 220 using directional control knobs 40 and 42 of control module 14. The physician continues to advance operating capsule 12 and flexible tubular member 16 until
10 operating capsule 12 arrives at tip extremity 218, where the malignant, diseased or otherwise undesirable tissue to be resected is located.

 Once operating capsule 12 is at this position, the physician withdraws flexible tubular transmission means
15 slightly from apparatus 10 thereby withdrawing tip extremity 218 from aperture 238 into the position illustrated generally in Figure 31 where tip extremity 218 is within operating capsule 12. With tip extremity 218 at this position, the physician or other attending
20 health care professional proceeds to use tissue grabbers 194 to grasp the colon wall tissue, drawing the colon wall tissue (including the malignant, other diseased or otherwise undesirable colon wall tissue) into the interior of operating capsule 12 to a position generally
25 illustrated in Figure 31 where the malignant, other diseased or otherwise undesirable tissue is preferably entirely within the interior of operating capsule 12 and outer surface 212 of luminal wall 208 is folded upon itself. Once the physician has manipulated the tissue
30 into this position using tissue grabbers 194, the physician actuates ramp-knife assembly 50 to perform the stapling and tissue cutting functions as illustrated in Figure 31.

 Once tissue stapling and cutting has been
35 performed, operating capsule 12 may be closed thereby to retain the malignant, other diseased or otherwise

-44-

undesirable tissue in a position where it does not contact the remaining and presumably healthy luminal wall tissue outside of operating capsule 12.

5 If desired, the physician may then advance tip
extremity 218 and flexible tubular transmission means
220 of endoscope 216 relative to apparatus 10 to cause
tip extremity 218 to once again protrude from aperture
238. The physician may then slightly withdraw apparatus
10, specifically operating capsule 12 and flexible
10 tubular member 16, thereby removing operating capsule 12
from the immediate vicinity of the wound site. This
permits the physician to inspect the wound site using
endoscope 16 by manipulating tip extremity 218
protruding out of aperture 238. If the endoscope 216 is
15 equipped with cauterizing heaters and if cauterizing of
the stapled wound is necessary to prevent any excessive
bleeding, this may be performed using endoscope 216,
particularly tip extremity 218 protruding from aperture
238.

20 Once the surgical procedure has been completed and
the physician is satisfied with the results, flexible
tubular member 16 and operating capsule 12 are withdrawn
from the colon. Flexible tubular transmission means 220
of endoscope 216 may be simultaneously withdrawn in a
25 unitary motion with operating capsule 12 and flexible
tubular member 16 or, if further inspection of the wound
site is desired, flexible tubular transmission means 220
of endoscope 216 may be removed from the colon after
such further inspection has been performed.

30 While the foregoing description has discussed
performing cauterization of the wound using endoscope
216, it is within the purview of the invention to
provide separate cauterizing means as an accessory or an
auxiliary item within operating capsule 12. Similarly,
35 it is within the purview of the invention to provide
multiple ports, such as aperture 238, for viewing the

-45-

lumen interior where the surgical procedure is being performed.

5 Additionally, while the foregoing description has concentrated on use of an endoscope such as endoscope 216 illustrated generally in the drawings, it is within the purview of the invention to use apparatus 10 together with a colonoscope or an ectoscope or to use apparatus 10 in a catheter-guided fashion.

10 Operating capsule 12 may be constructed in various shapes differing from that illustrated in the drawings. Particularly, operating capsule 12 may be constructed in the shape of a hemisphere of an American football where the football has been divided in half along a vertical plane. In such case, aperture 238 might be provided at 15 the point of the football. In such case, the operating capsule could open at the equator of the half-football or at the position above or below the equator.

Further respecting operating capsule 12, the opening between upper and lower shell portions 22, 24 20 need not be configured to be along the horizontal mid point of operating capsule 12.

Tissue grabbers 194 have been illustrated as including finger rings 198 and a thumb ring 200. Tissue grabbers 194 may equally well be provided with trigger- 25 like means for controlling or actuating the tissue grabbers.

Further respecting tissue grabber means 194, while these means have been illustrated with alligator-like jaws, the tissue grabbing function could equally well be 30 performed by suction cups with the necessary vacuum supplied via the endoscope.

Referring to Figure 32, an alternate embodiment of an operating capsule manifesting aspects of the invention is illustrated schematically where the 35 operating capsule is designated generally 12'. In Figure 32, the operating capsule is illustrated divided

-46-

into two parts, 12'₁ and 12'₂. The apparatus illustrated schematically in Figure 32 is configured to endolumenally remove a cylindrical wall section of undesired luminal tissue and to circumferentially secure the remaining luminal wall tissue from either side about the site of cylindrical removal.

Further respecting Figure 32, a flexible tubular transmission means portion of a conventional endoscope is designated generally 220' and is illustrated schematically as including a tip extremity portion 218'.

Operating capsule 12' is configured generally cylindrically and, as illustrated, separates into two portions. Each portion of operating capsule 12' includes tissue grabbers, only the jaws of which have been illustrated schematically as 206' in Figure 32.

The respective cylindrical parts 12'₁ and 12'₂ have respective annular lips 27, 27' associated therewith. Lips 27, 27' are annular or circular and are made to be closely spaced one from another in a manner similar to upper and lower lips 26, 28 in the preferred embodiment of the apparatus described above. One of lips 27, 27' is equipped with tissue stapling or suturing and tissue cutting means of the same general type as illustrated in Figures 18 through 24 while the remaining one of lips 27, 27' is equipped with anvil surface means of the type generally illustrated in Figures 24 and 26. The tissue cutting means is preferably radially inboard of the tissue stapling or suturing means in lip 27 or 27'.

Further illustrated in Figure 32 is a luminal wall 208' which is generally cylindrical in configuration. As illustrated in Figure 32, an annular portion 209 of luminal wall tissue 208' has been drawn into a position at which cylindrical section 209 of luminal wall tissue 208 is configured with a smaller diameter than luminal wall tissue portion 208'. As such, cylindrical luminal wall portion 209 has a diameter sufficiently less than

-47-

the diameter of operating capsule 12' that cylindrical lumenal wall portion 209 is completely within a cylindrical envelope defined by the interior of operating capsule 12'. Lumenal wall 208 is drawn into this position using tissue grabbers 206'.

Once lumenal wall 208' and cylindrical section thereof 209 are in the position illustrated in Figure 32, the two parts 12', and 12', of operating capsule 12' are brought together to position lips 27, 27' in close proximity to one another. At this position, the tissue stapling or suturing means and tissue cutting means are actuated thereby suturing together portions of lumenal wall denoted 350 which are trapped between lips 27, 27'. The stapling or suturing apparatus is configured to actuate all of the staples or sutures located around circular lip 27 or 27' simultaneously so that portions 350 of lumenal wall tissue are stapled or sutured together around the complete circle defined by lip 27, 27' at one time.

Once the tissue suturing or stapling and tissue cutting operation has been performed, cylindrical section 209 of lumenal wall tissue 208 is retained within operating capsule 12' whereupon operating capsule 12' is removed from the lumen. The lumenal wall tissue remains, having had a cylindrical section removed therefrom, with an annular, 360° line of suturing or staples securing together portions of cylindrical lumenal wall 208' from which cylindrical wall section 209 has been removed.

Operation of operating capsule portions 12', and 12', occurs using cables, an operating control module and a flexible cable carrying member such as illustrated in Figures 1 through 31. A greatly radially foreshortened version of flexible cable carrying member 16 may be provided about endoscope 220', between operating capsule sections 12', and 12', to carry cables between the two

-48-

sections of the operating capsule in order to close the cylindrical sections of the operating capsule upon one another to bring lips 27, 27' into proximity with one another to be in a position to effectuate the tissue
5 securement and cutting functions.

CLAIMS

1. Apparatus for endolumenally removing undesired luminal tissue and securing remaining luminal tissue about the site of removal comprising means for fastening together portions of luminal tissue adjacent to undesired luminal tissue to prevent creation of an aperture in said lumen which would otherwise result upon removal of said undesired luminal tissue.
2. Apparatus of claim 1 further comprising means for detaching said undesired luminal tissue from said lumen.
3. Apparatus for endolumenally removing a wall section of undesired luminal tissue and securing remaining luminal wall tissue from either side about the site of removal, comprising:
- a. means for sequentially and simultaneously:
- i. fastening together portions of luminal tissue which are adjacent to undesired luminal tissue to prevent creation of an aperture in said lumen which would otherwise be created upon removal of said undesired luminal tissue; and
- ii. detaching said undesired luminal tissue from said lumen.
4. A method for endolumenally resectioning luminal tissue by anastomosing the tissue with artificial fastening means, comprising:
- a. inserting a tissue suturing and cutting instrument into a body lumen through a naturally occurring body orifice;
- b. advancing said instrument within said lumen to an area of undesired luminal tissue to be resectioned;
- c. drawing said undesired luminal tissue into a cutting zone associated with said instrument;

-50-

- d. stapling said surrounding lumenal tissue to close an orifice which would otherwise result from removal of said undesired lumenal tissue;
 - e. cutting said undesired lumenal tissue from surrounding lumenal tissue.
- 5
5. Apparatus for endolumenally resectioning diseased lumenal tissue and reanastomozing remaining lumenal tissue with fastening means, comprising;
- a. means for gripping lumenal tissue on respective sides of said diseased tissue and pulling said gripped tissue and said diseased tissue surrounded thereby into a cutting zone removed from an undisturbed position of said lumenal tissue;
 - 10
 - b. means for detaching said diseased lumenal tissue from surrounding healthy lumenal tissue; and
 - 15
 - c. means for fastening healthy lumenal tissue together across an aperture therein created by detachment of said diseased lumenal tissue from said healthy lumenal tissue, to close said aperture.
 - 20
6. Endolumenal surgical apparatus comprising:
- a. a longitudinally elongated lip;
 - 25
 - b. suturing means in said lip for passing through tissue positioned along said lip and thereby securing said tissue together;
 - c. suture advancement and tissue cutting means movable along said lip, for advancing said suturing means through said tissue thereby effectuating suturing securement of tissue and cutting said tissue inboard of said sutured securement.
 - 30
7. Apparatus for advancing an endolumenal operating capsule along and within a body lumen by transmitting manually applied force thereto along
- 35

-51-

a curvilinear path, connecting said capsule to an operator control module external of the body and transmitting control signals from said control module to said operating capsule, comprising:

- 5 i. a pair of annularly spaced flexible tubular sheaths;
- ii. means including a plurality of apertures for residence of operating control signal transmission means therein and
10 transmitting axial force as said apparatus bends to define said curvilinear path while limiting such curvilinear bending of said apparatus to a preselected degree;
- 15 iii. longitudinally elongated sinuous means, extending the length of said apparatus and resident within said axial force transmission means, for transmitting said control signals from said control module
20 to said operating capsule.

8. Apparatus for endolumenally removing a cylindrical wall section of undesired luminal tissue and circumferentially securing remaining luminal wall tissue from either side about the site of said
25 cylindrical removal, comprising:

- a. means for
 - 30 i. fastening together circular margins of luminal tissue which are adjacent to said undesired cylindrical luminal tissue to prevent creation of a breach in said lumen which would otherwise be created upon removal of said undesired cylindrical luminal tissue; and
 - 35 ii. cutting said undesired cylindrical luminal tissue from said lumen radially

-52-

inboard of said fastened together circular margins.

9. A method for endolumenally cylindrically resectioning luminal tissue comprising:
- 5 a. inserting a tissue suturing and cutting instrument into a body lumen through a naturally occurring body orifice;
- b. advancing said instrument within said lumen to an area of undesired luminal tissue to be
- 10 cylindrically resectioned;
- c. drawing said undesired cylindrical luminal tissue into an annular cutting zone associated with said instrument;
- d. stapling said surrounding luminal tissue about
- 15 annular margins of said cylindrical tissue to close an orifice which would otherwise result from removal of said undesired luminal tissue;
- e. cutting said undesired cylindrical luminal tissue from surrounding luminal tissue.
- 20 10. Apparatus for endolumenal tubular resection comprising:
- a. a continuous annular lip;
- b. suturing means in said lip for passing through tissue positioned around said lip and thereby
- 25 securing said tissue together;
- c. suture advancement and tissue cutting means movable about said annular lip, for advancing said suturing means through said tissue thereby effectuating suturing securement of
- 30 tissue entirely about the annular lip and cutting said tissue inboard of said sutured securement.

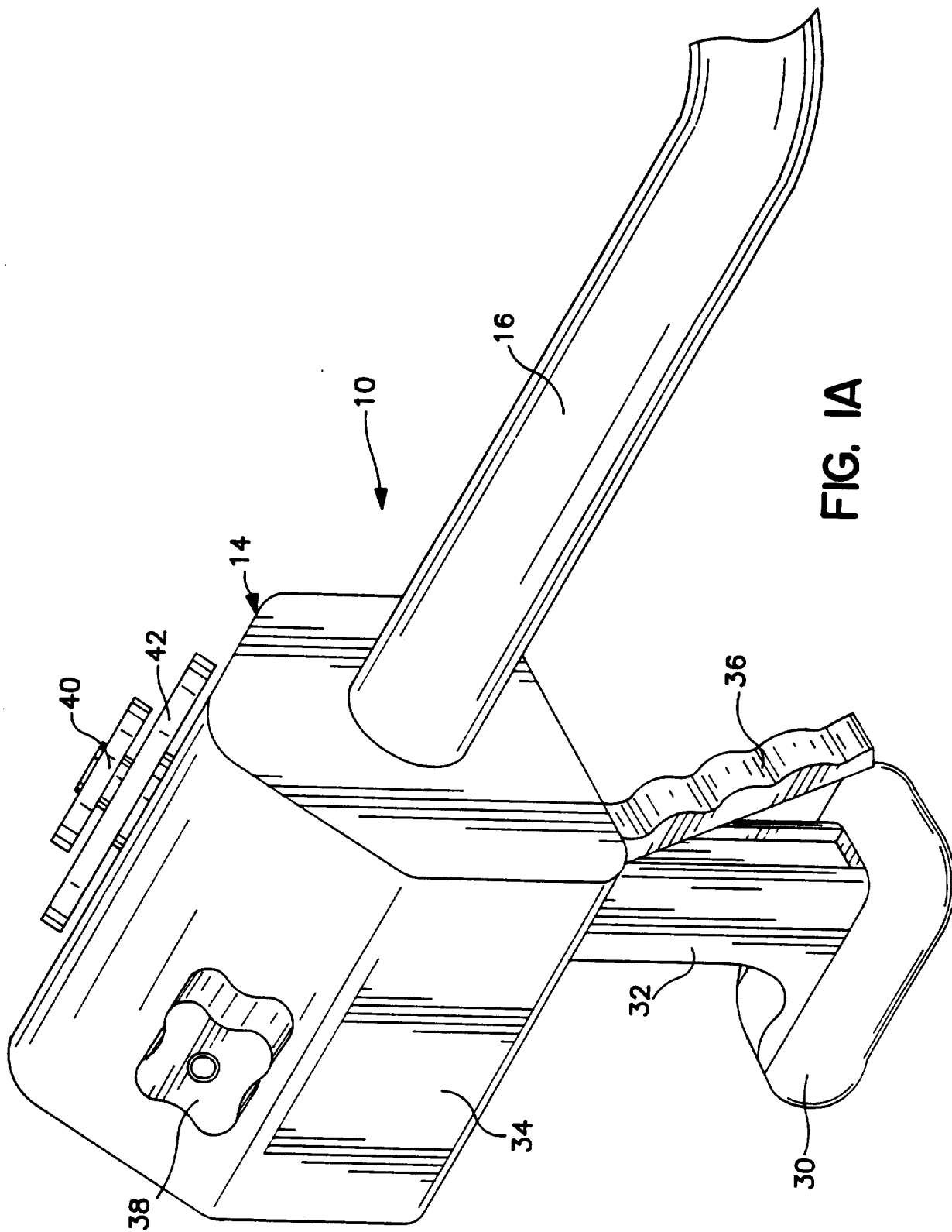

FIG. 1A

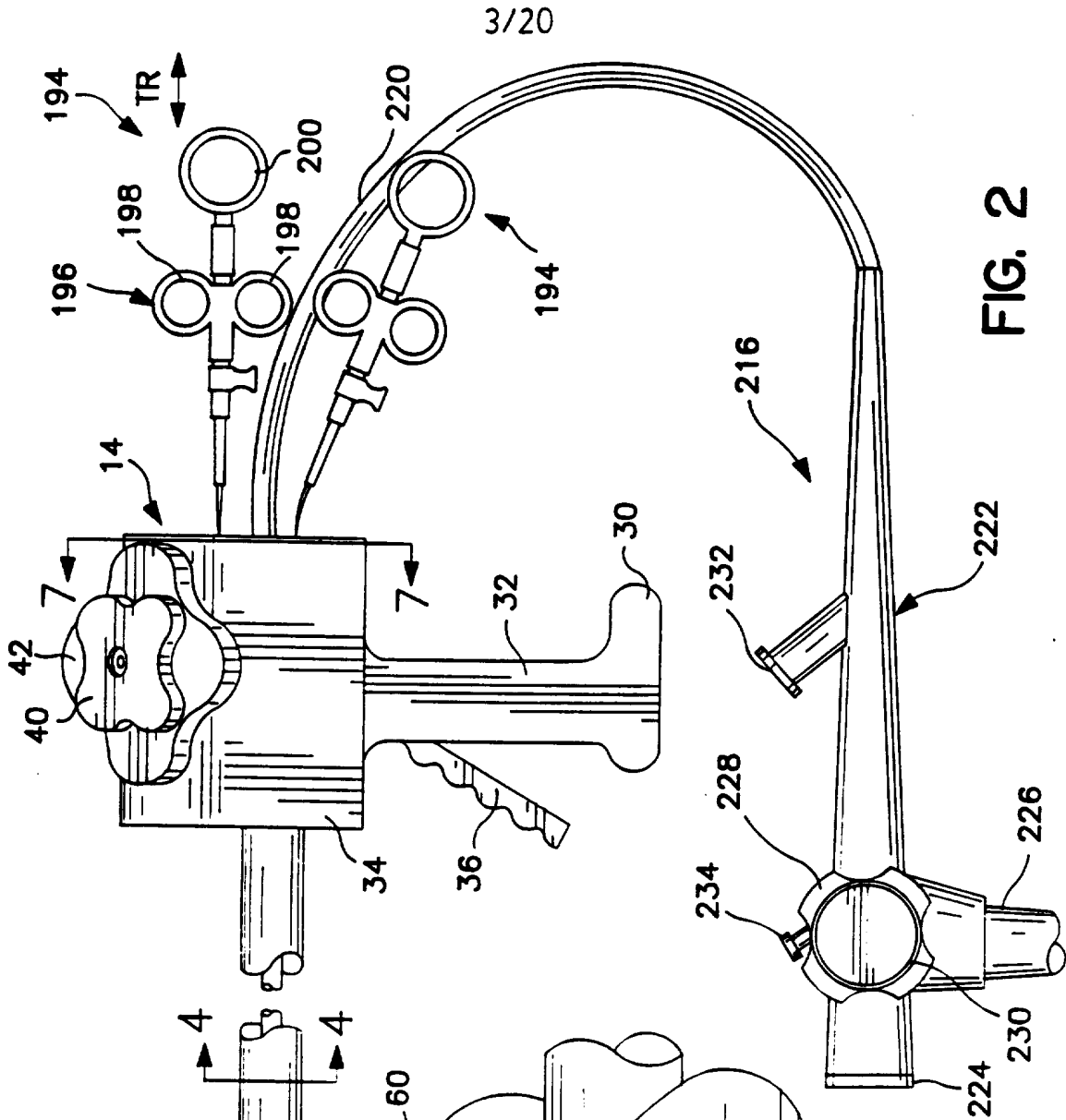

FIG. 2

SEE FIG. 3

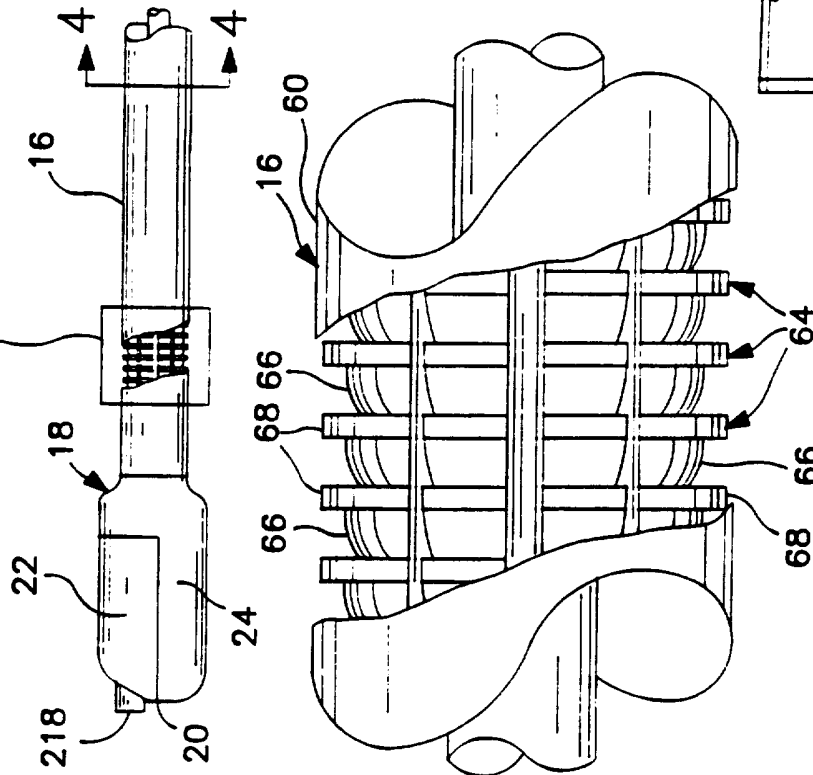

FIG. 3

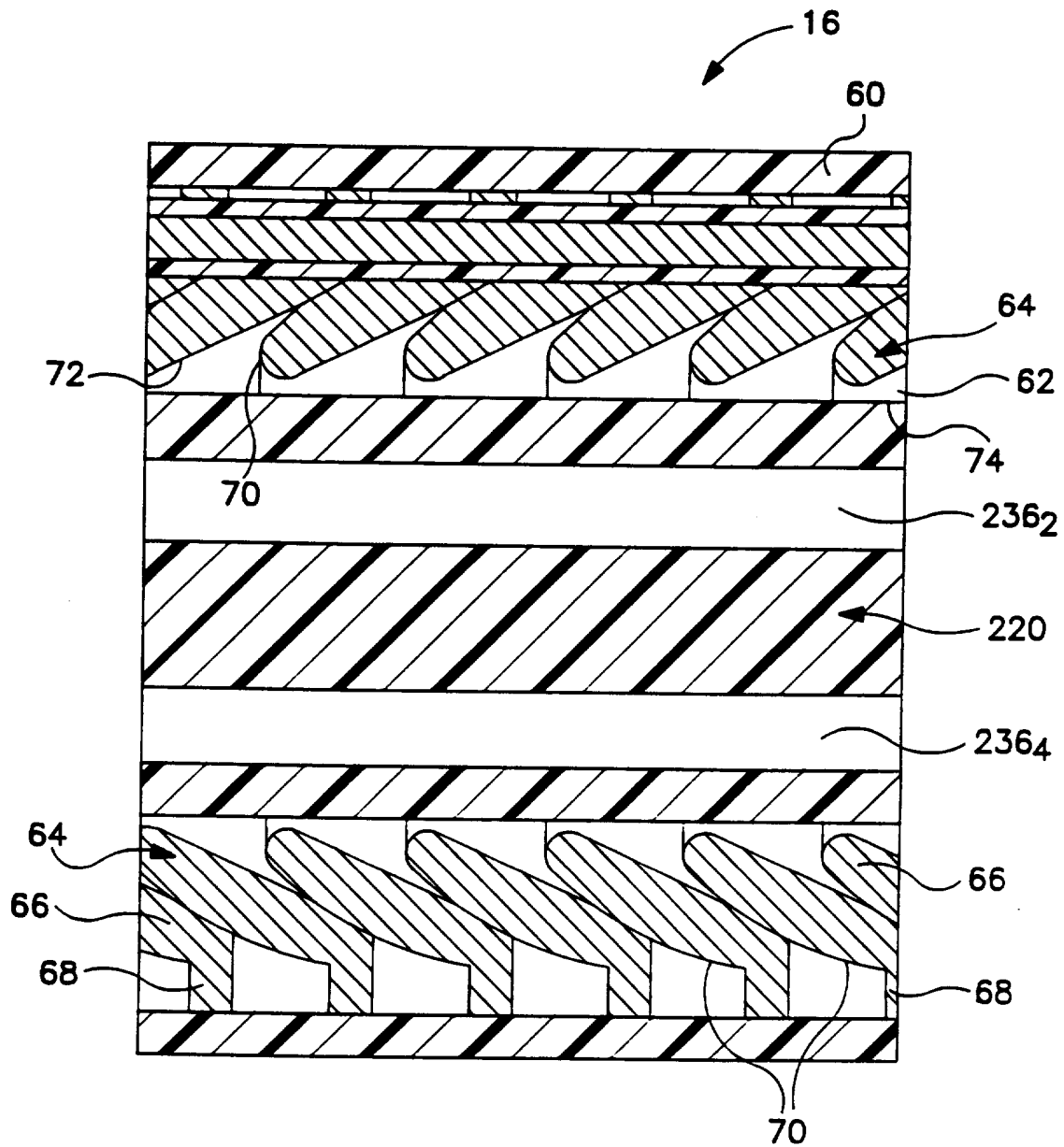

FIG. 5

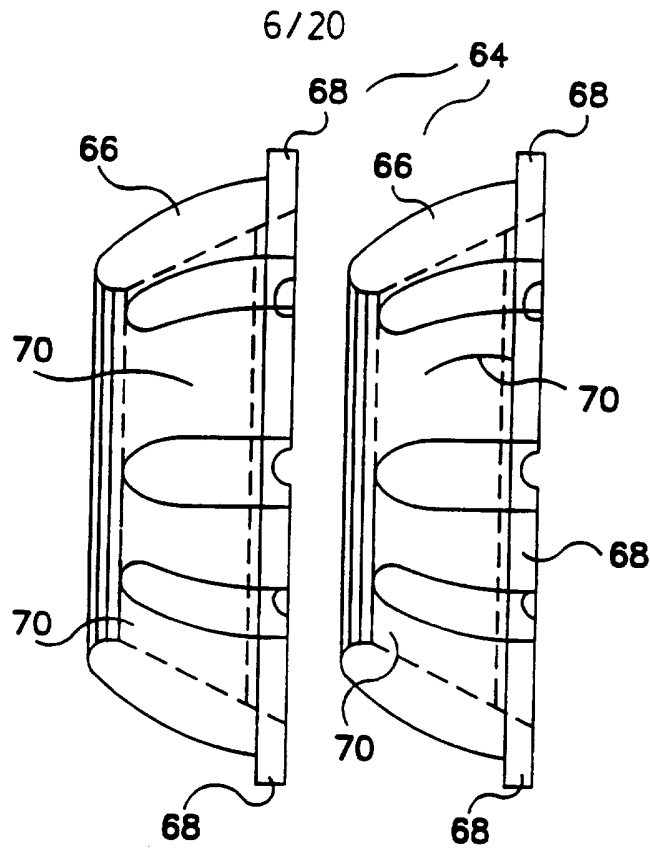

FIG. 6

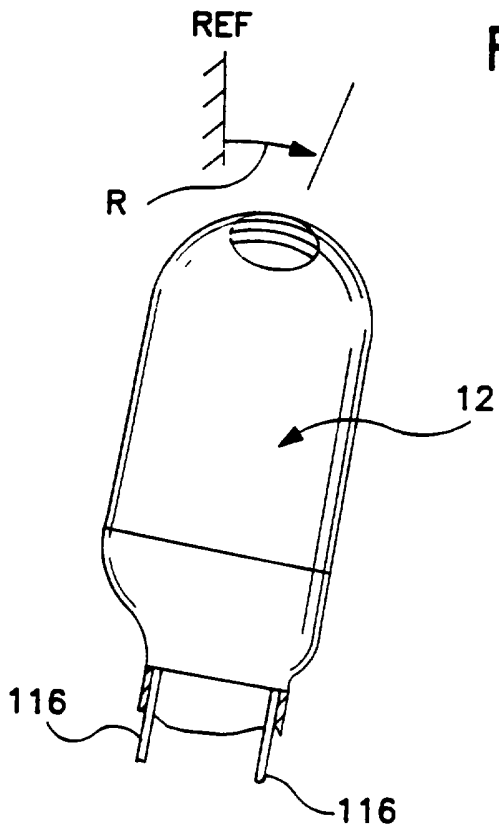

FIG. 8

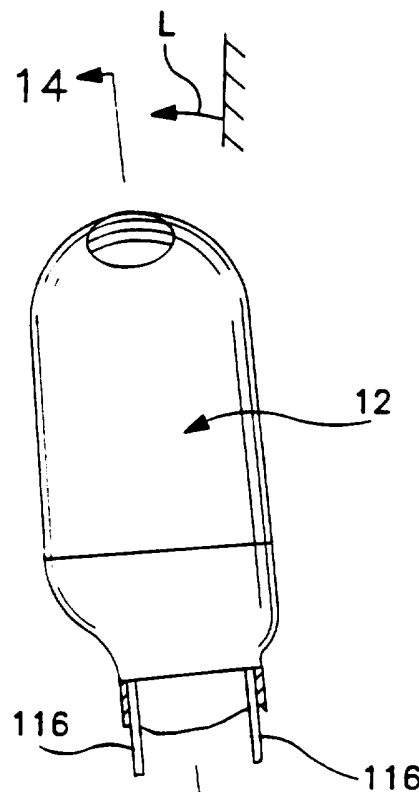

FIG. 9

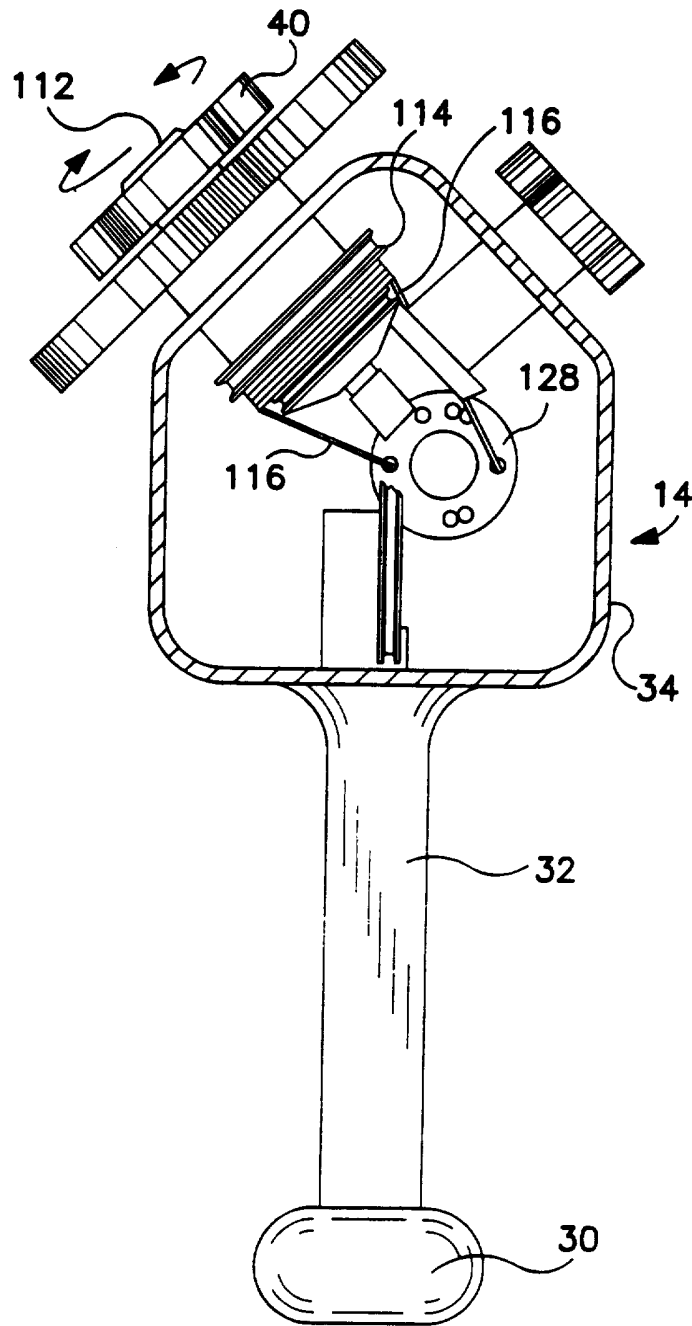

FIG. 7

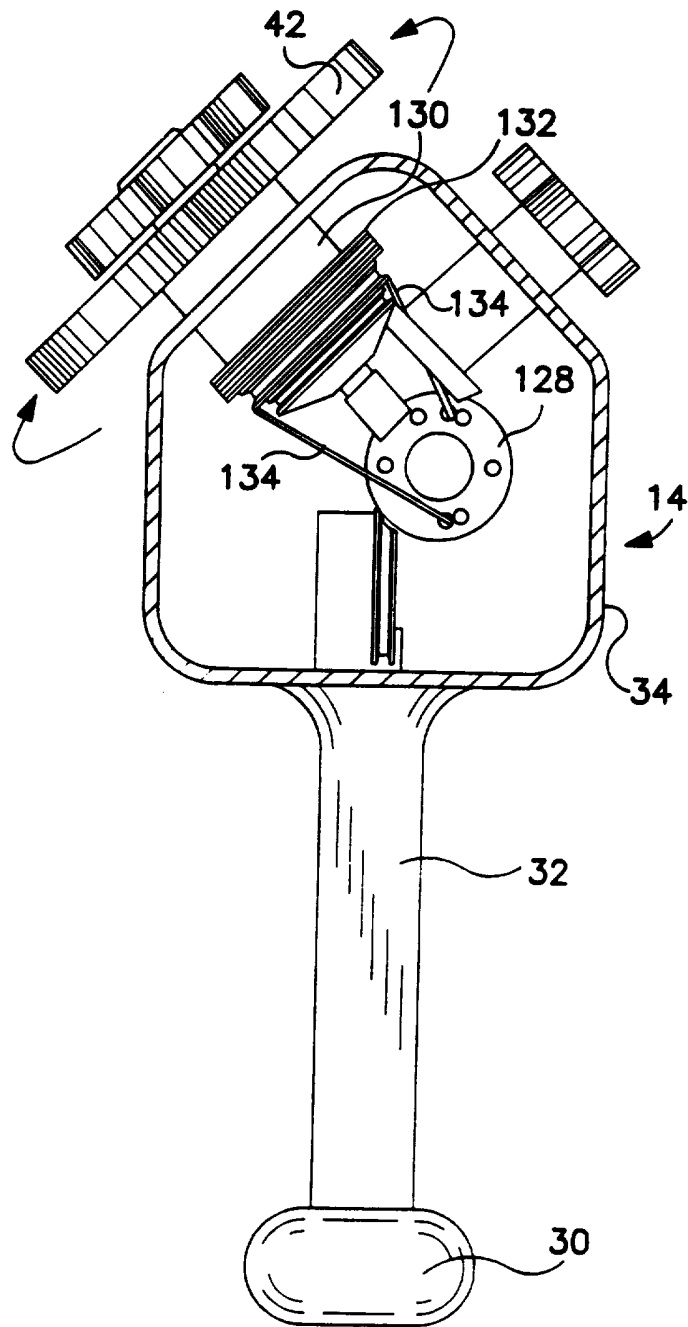

FIG. 10

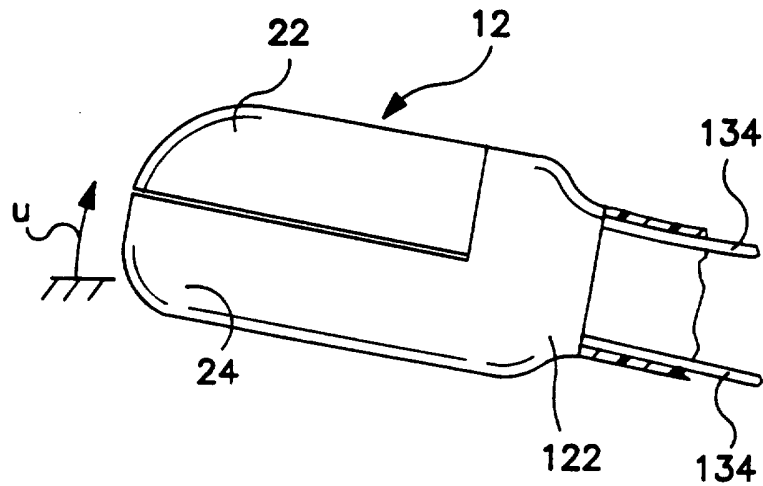

FIG. 11

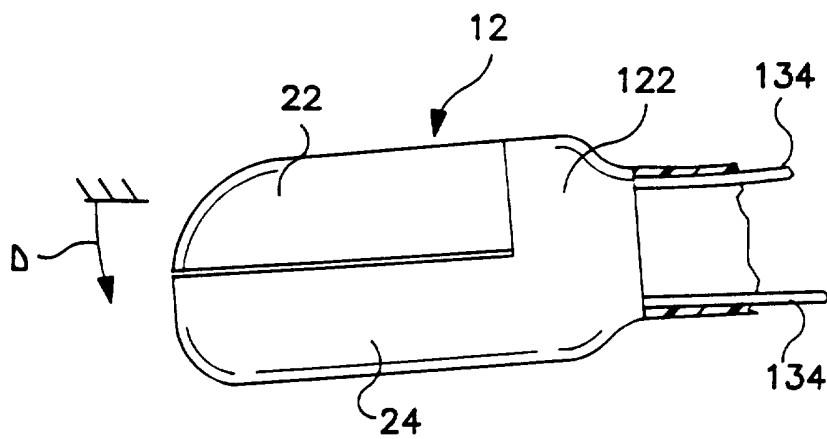

FIG. 12

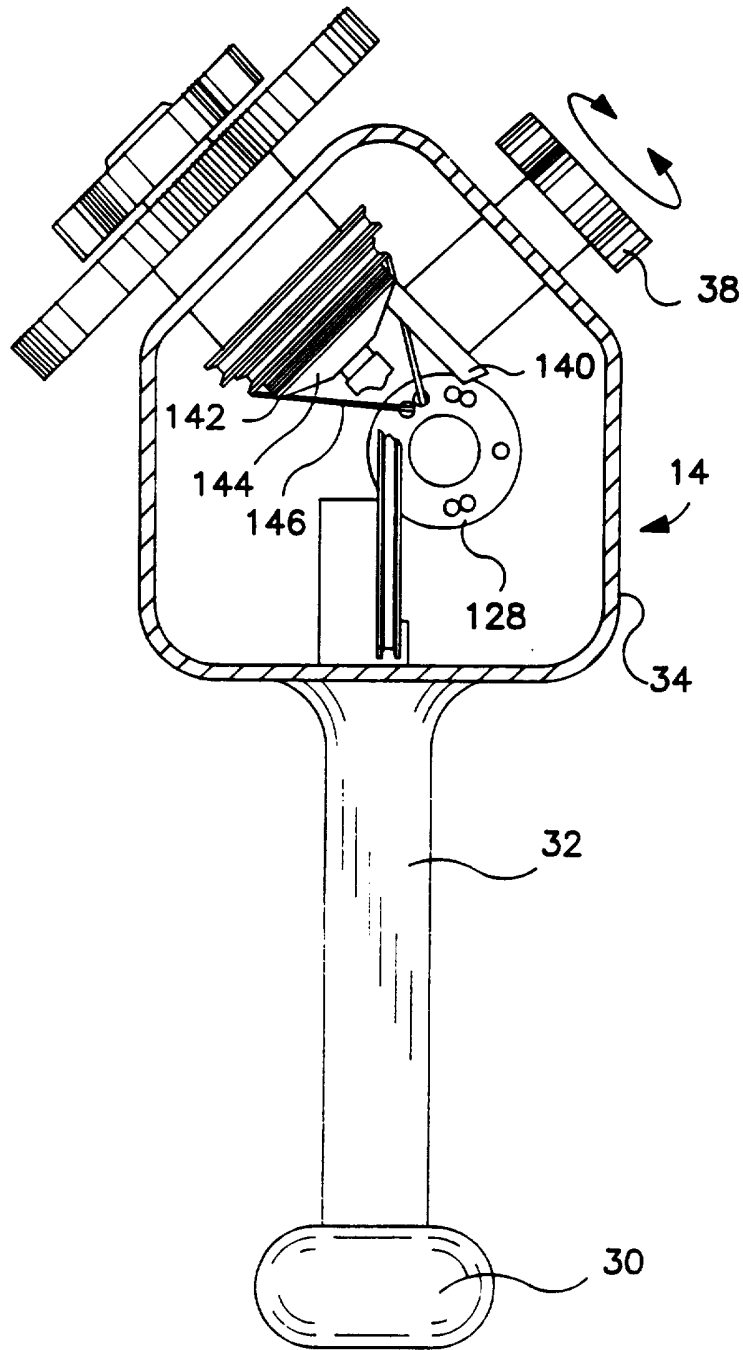

FIG. 13

11/20

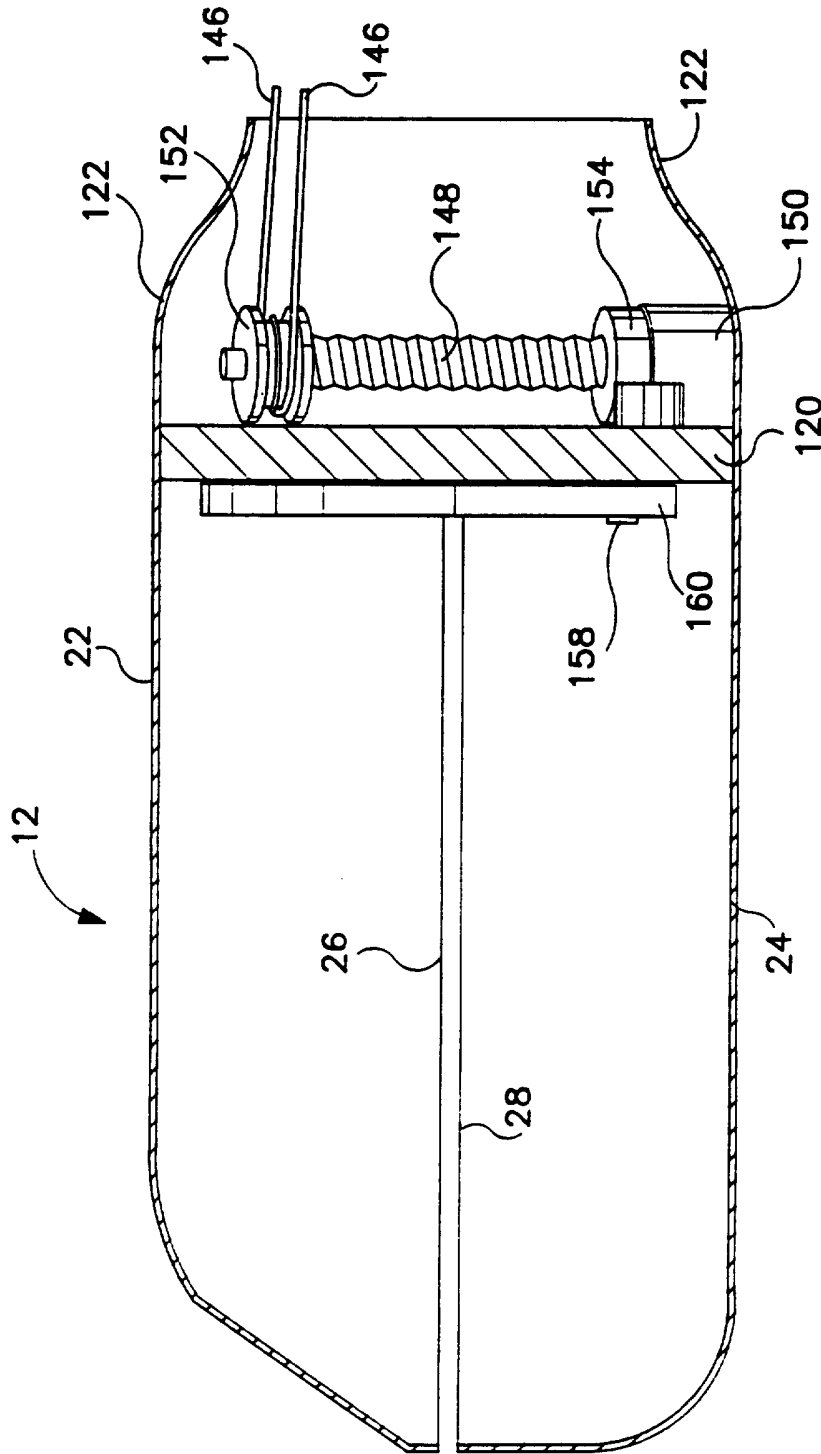

FIG. 14

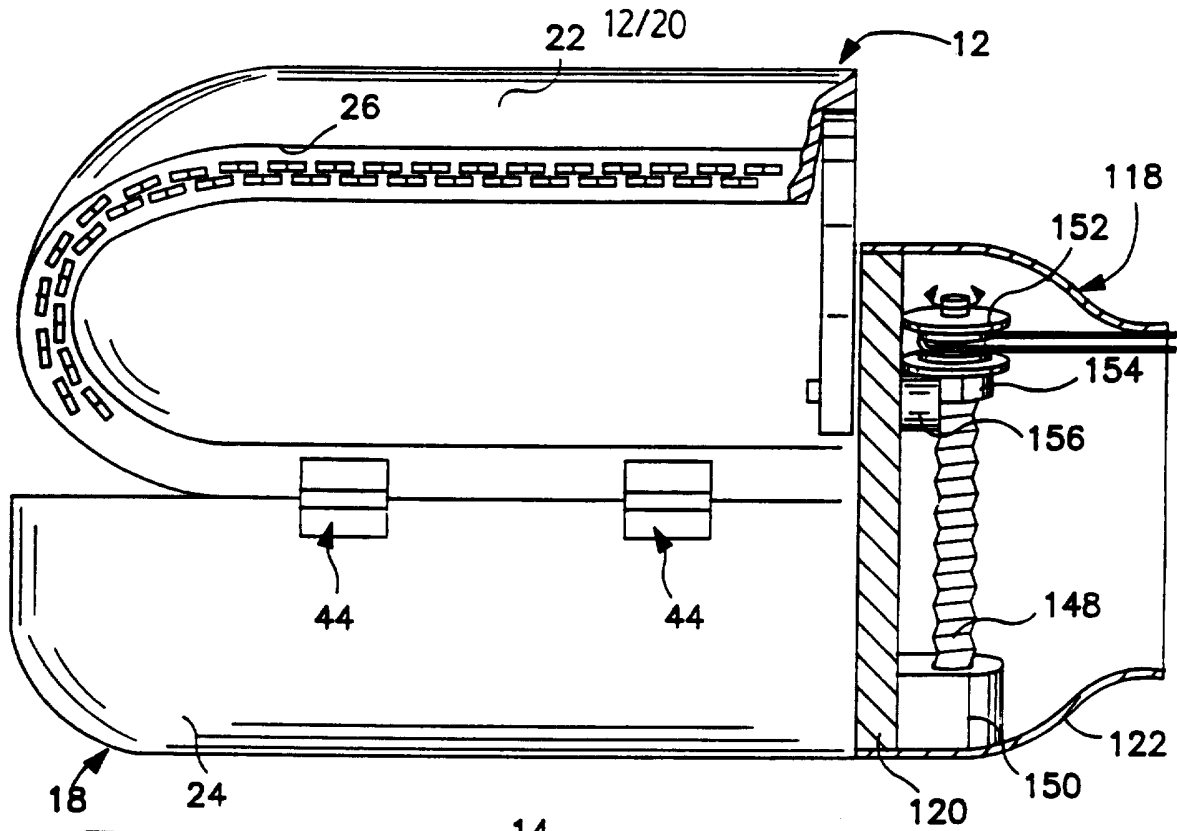

FIG. 15

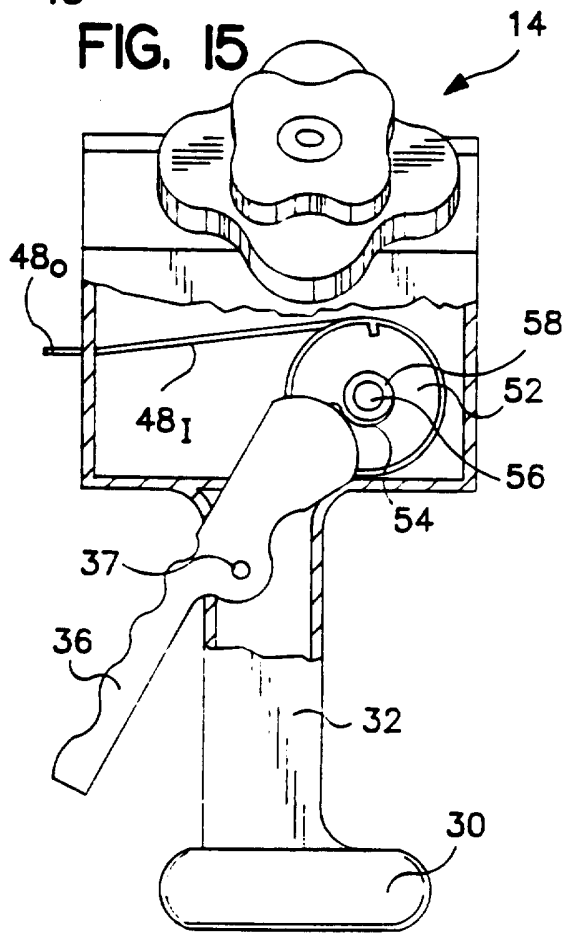

FIG. 16

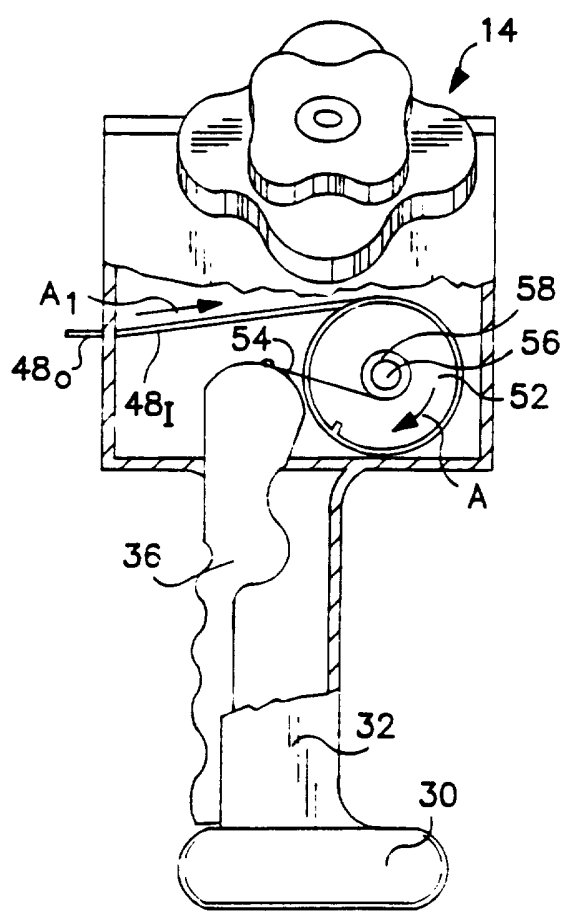
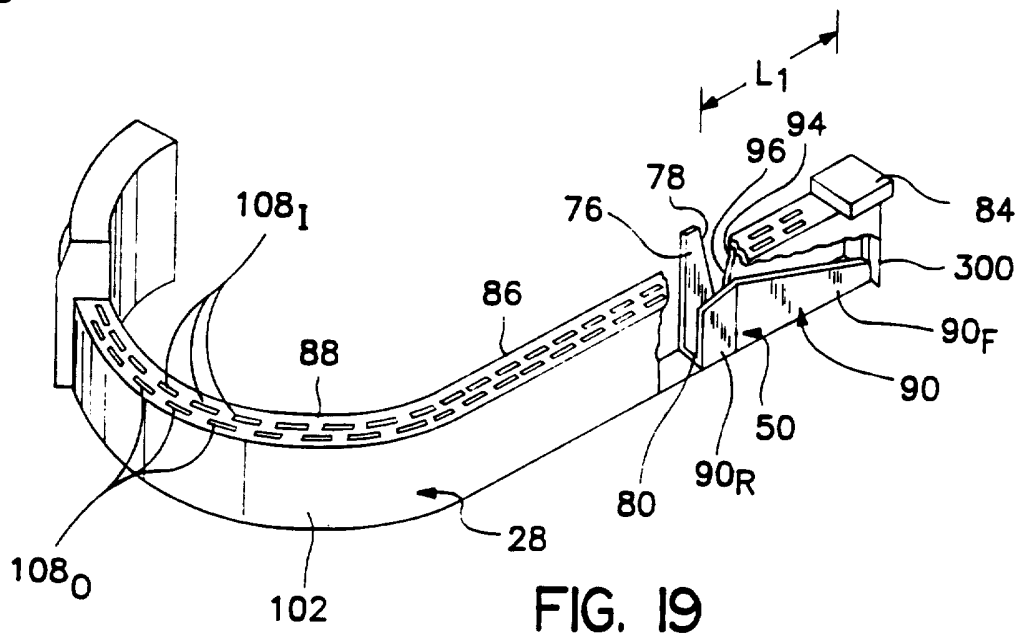
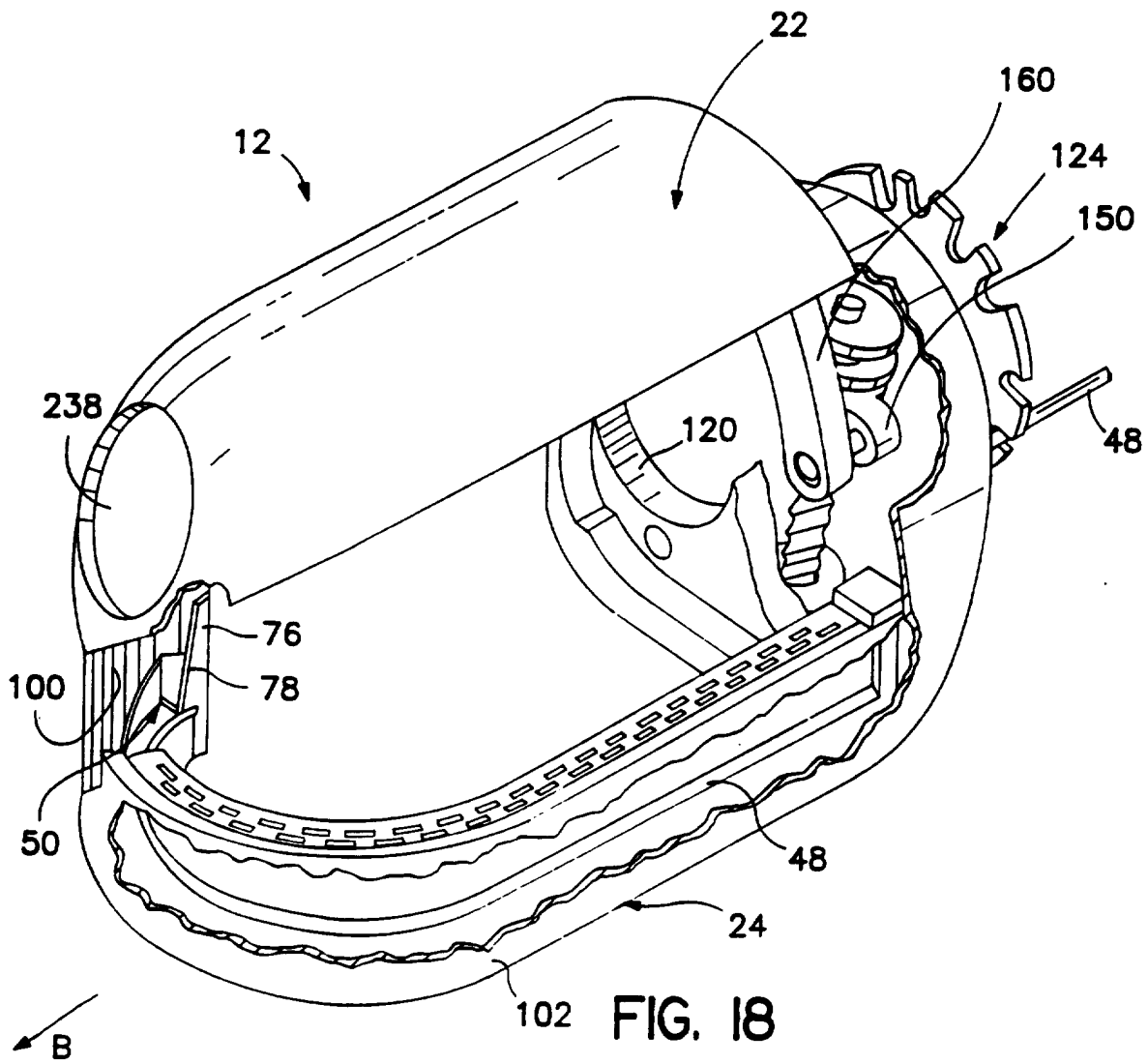

FIG. 17

13/20



14/20

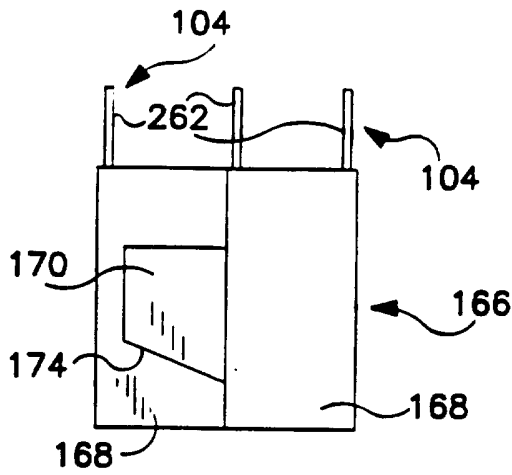

FIG. 20

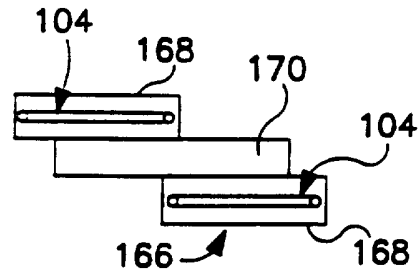

FIG. 21

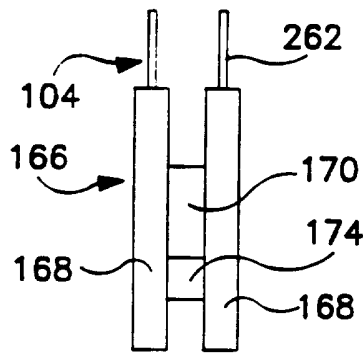

FIG. 22

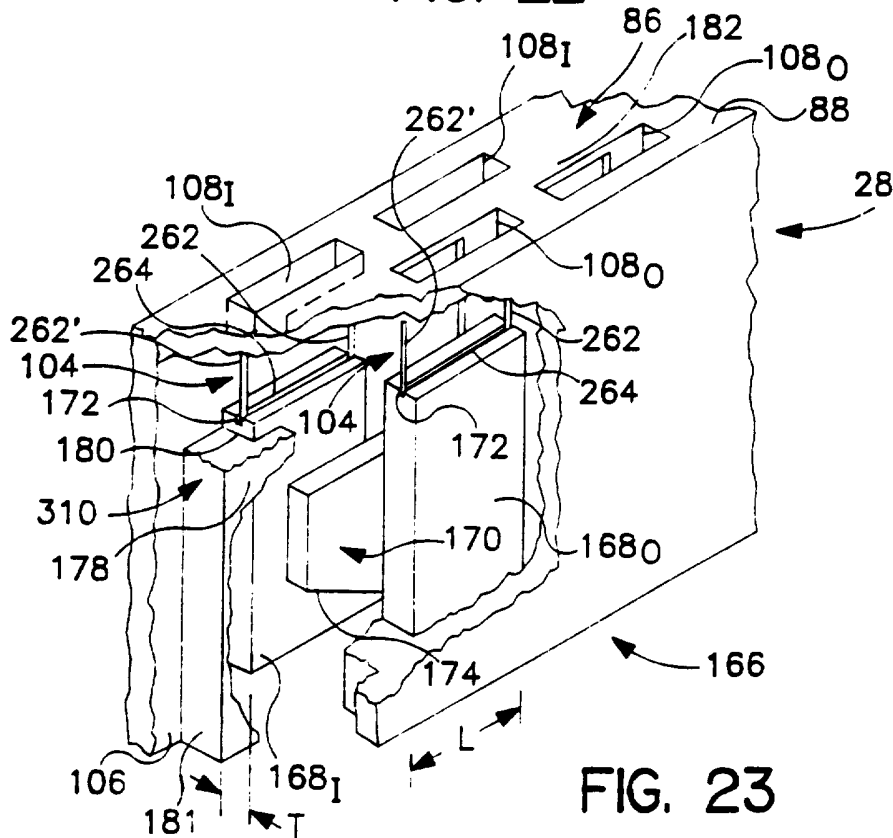

FIG. 23

16/20

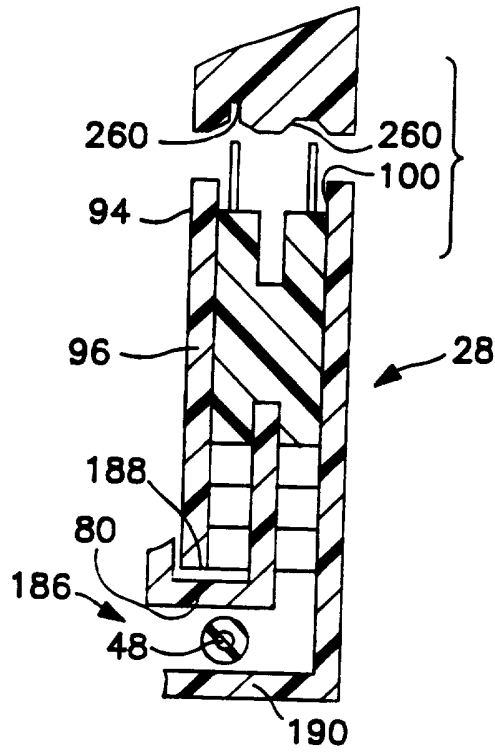

FIG. 26

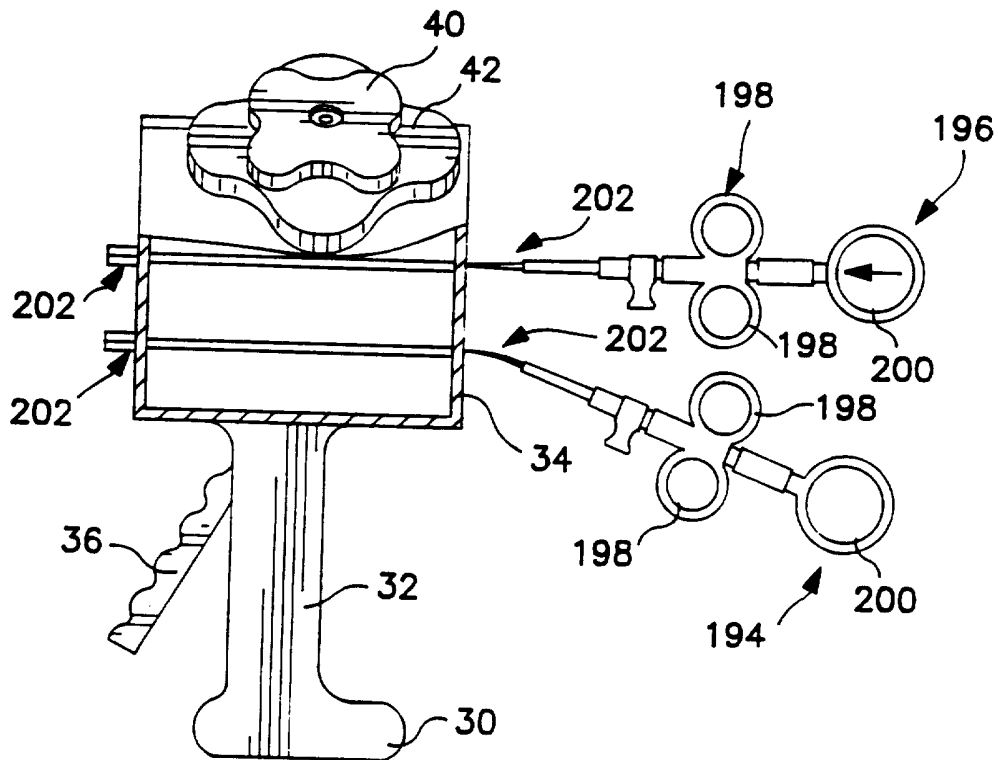

FIG. 27

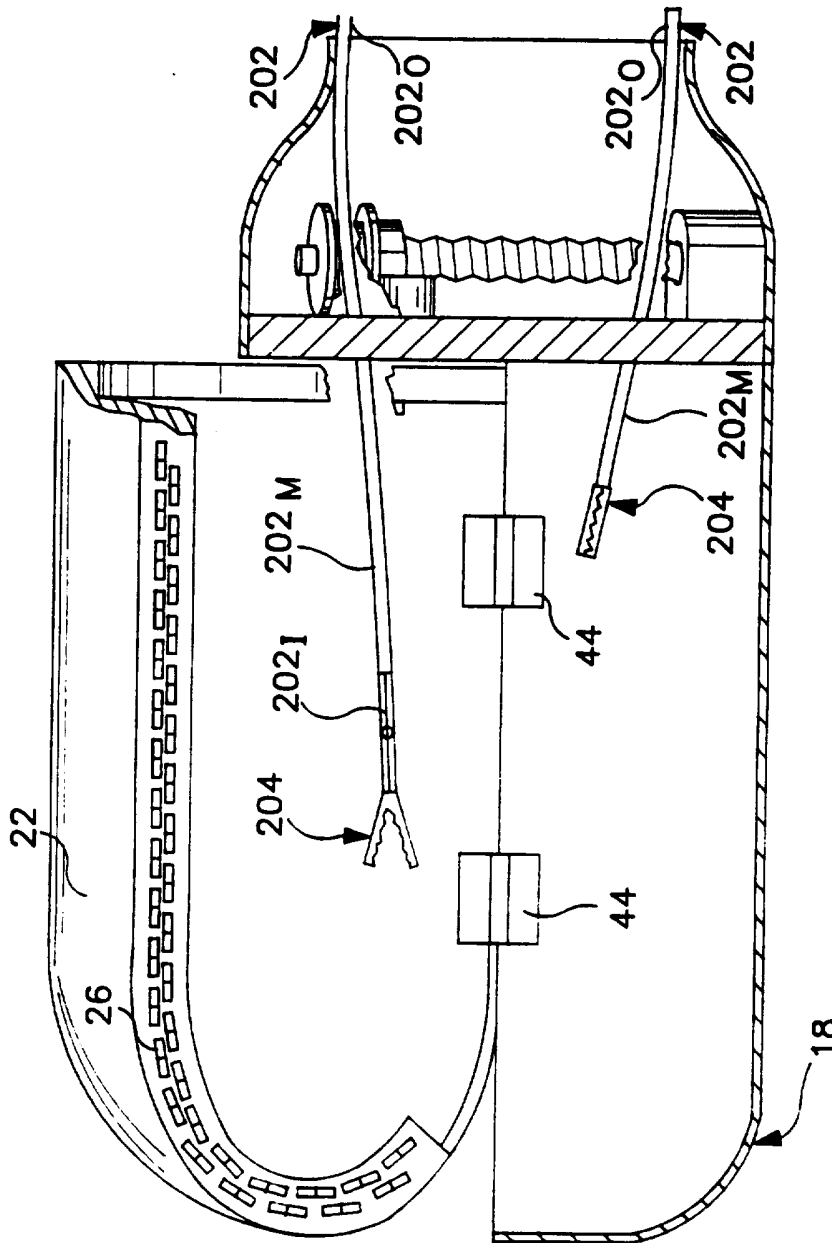

FIG. 28

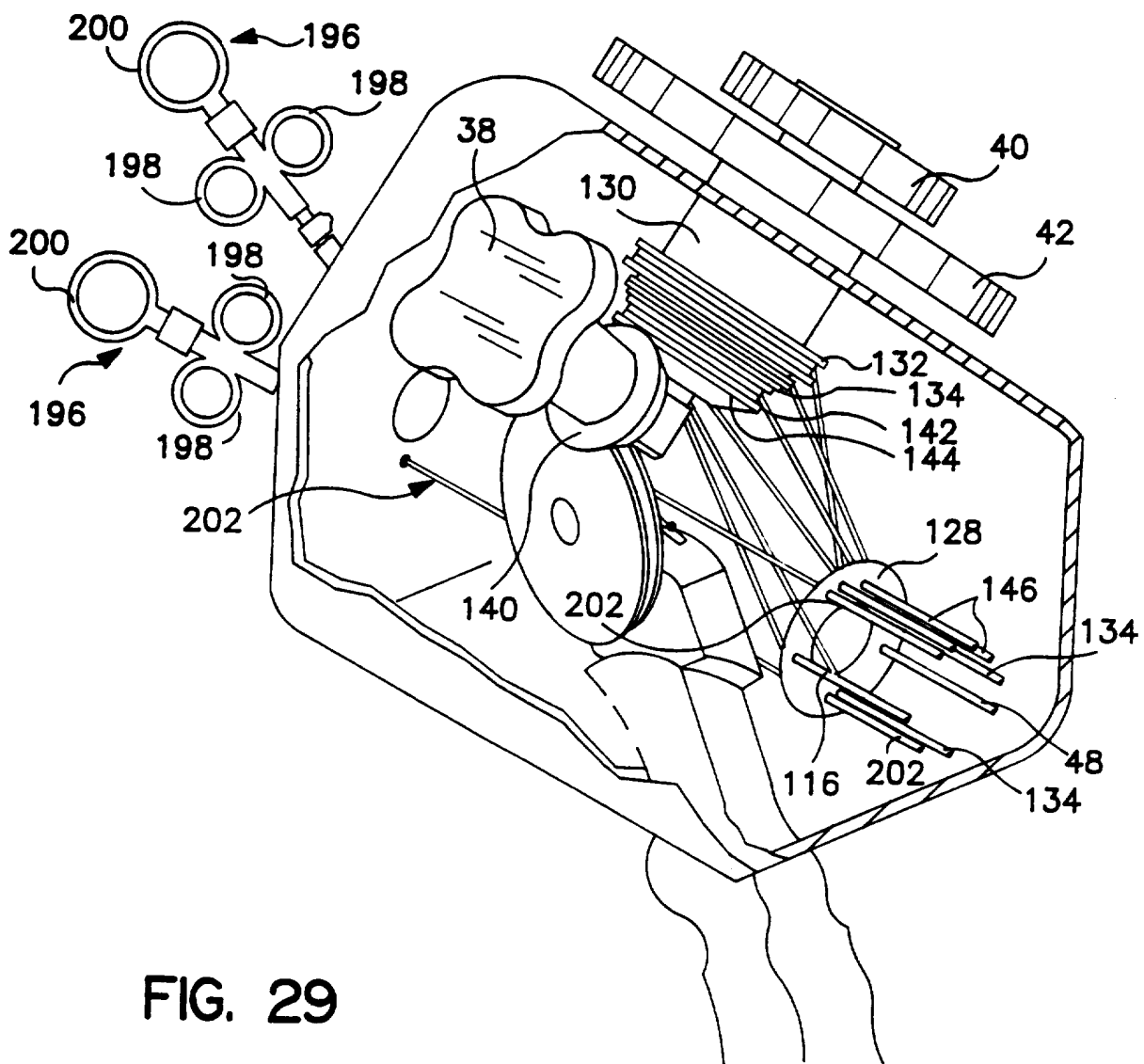
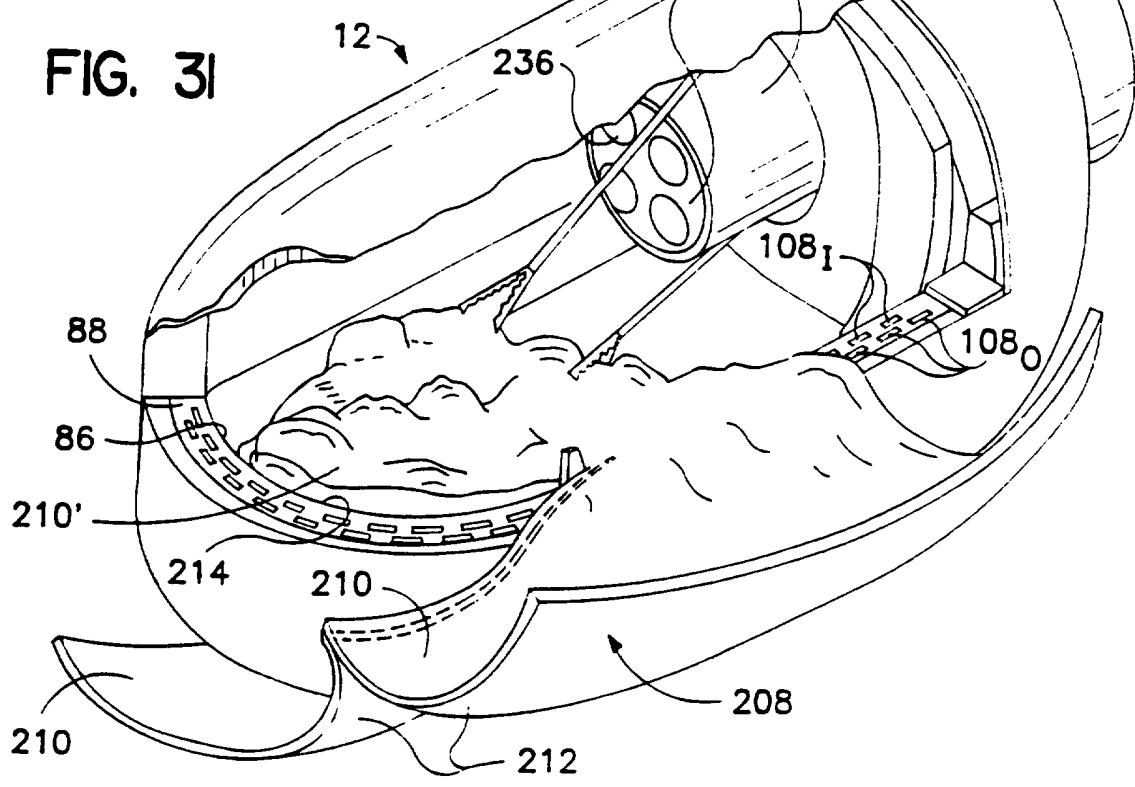
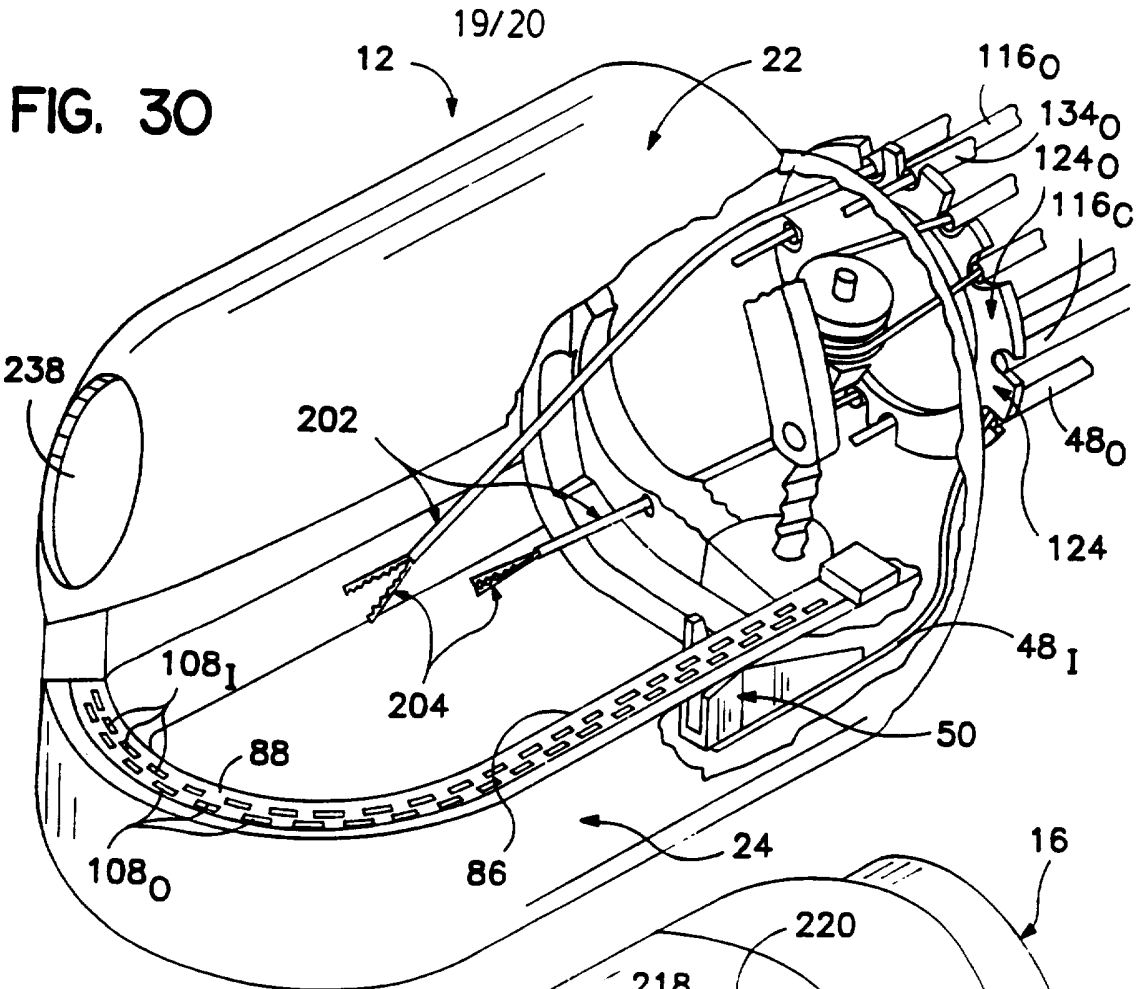

FIG. 29



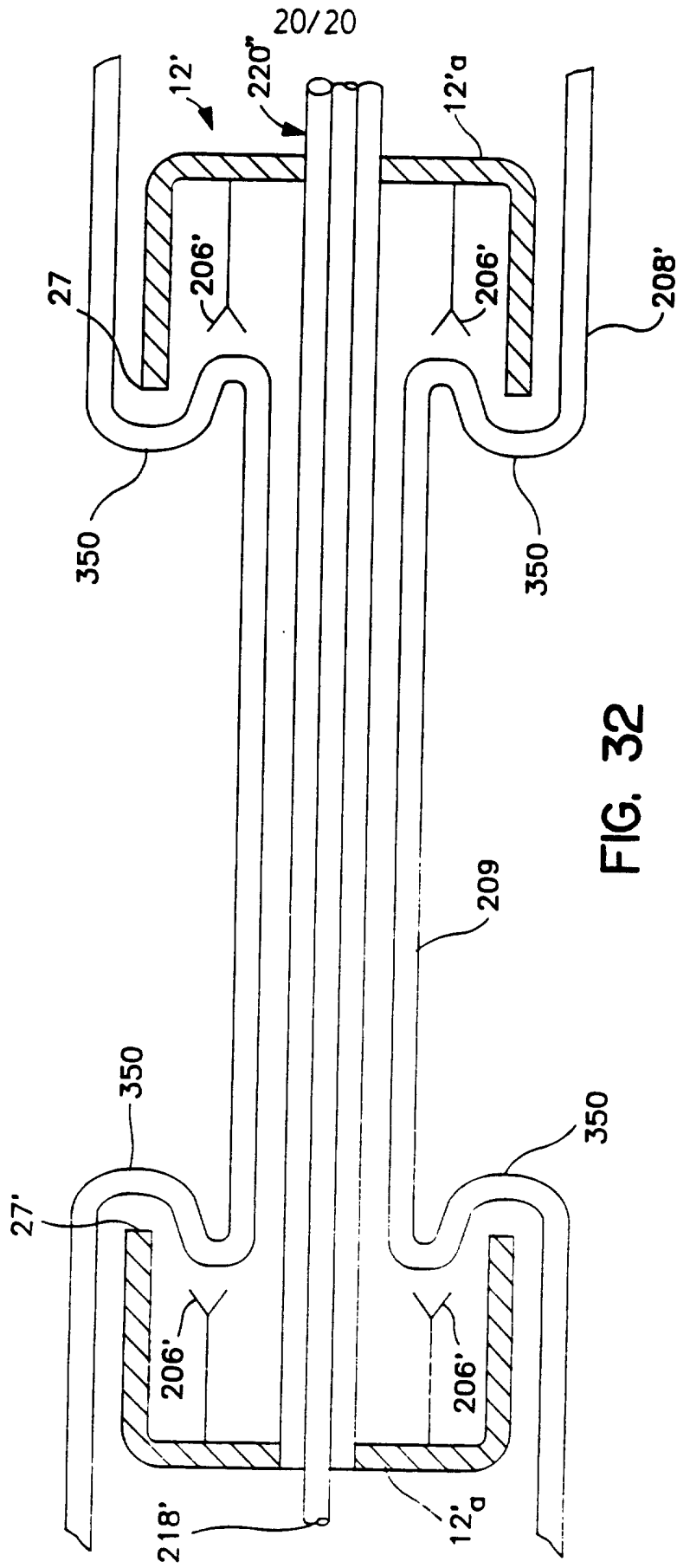

FIG. 32