

Feb. 8, 1966

L. F. HOWE

3,233,549

STRAINING, COLLECTING AND PUMPING SYSTEM

Filed April 22, 1963

2 Sheets-Sheet 1

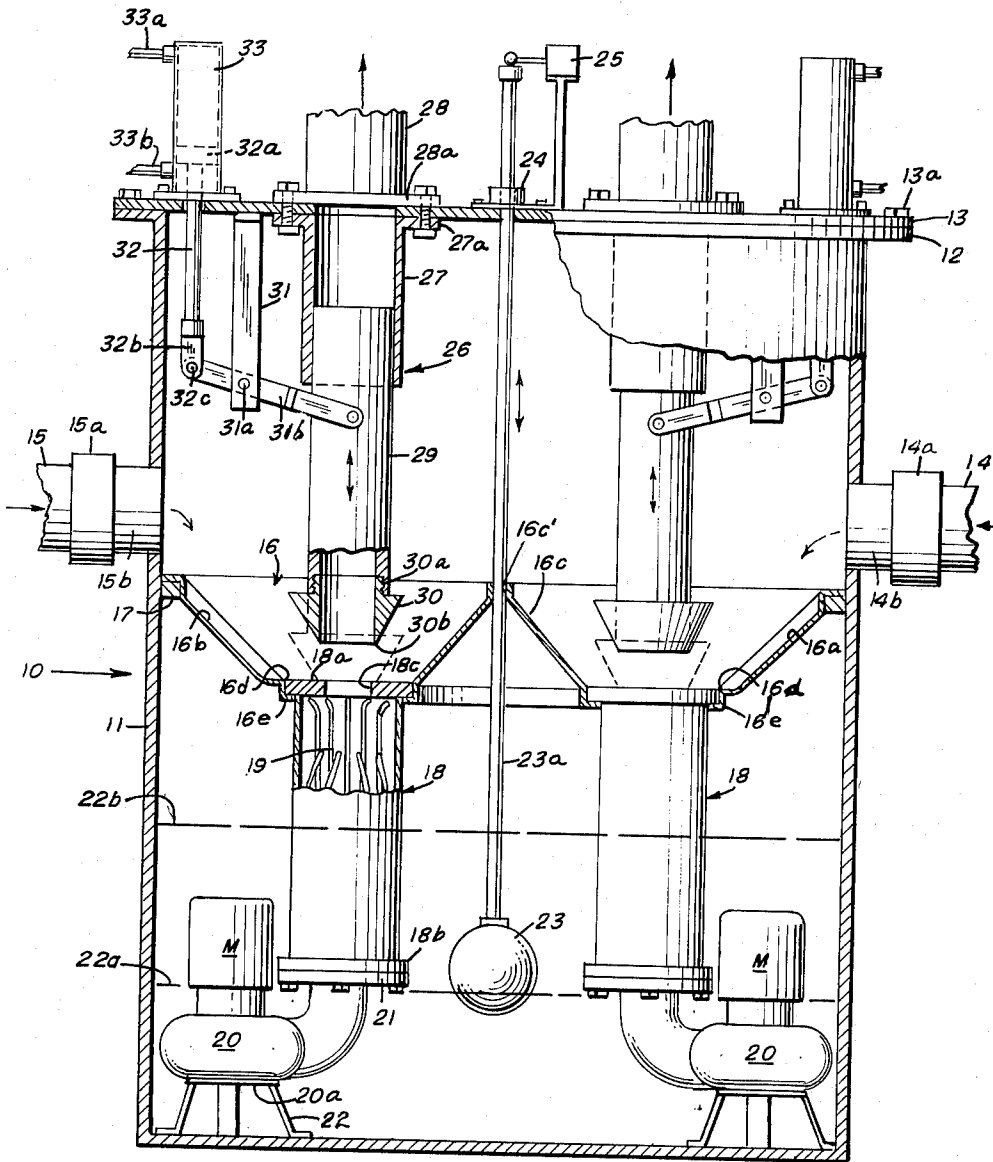

FIG. 1

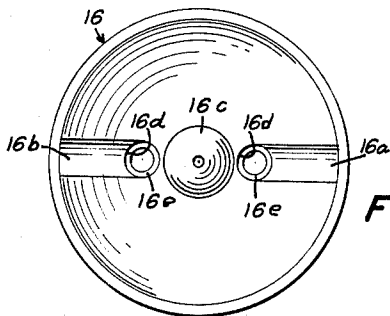

FIG. 2

INVENTOR  
LYLE F. HOWE

BY *Beale and Jones*  
ATTORNEYS

Feb. 8, 1966

L. F. HOWE

3,233,549

STRAINING, COLLECTING AND PUMPING SYSTEM

Filed April 22, 1963

2 Sheets-Sheet 2

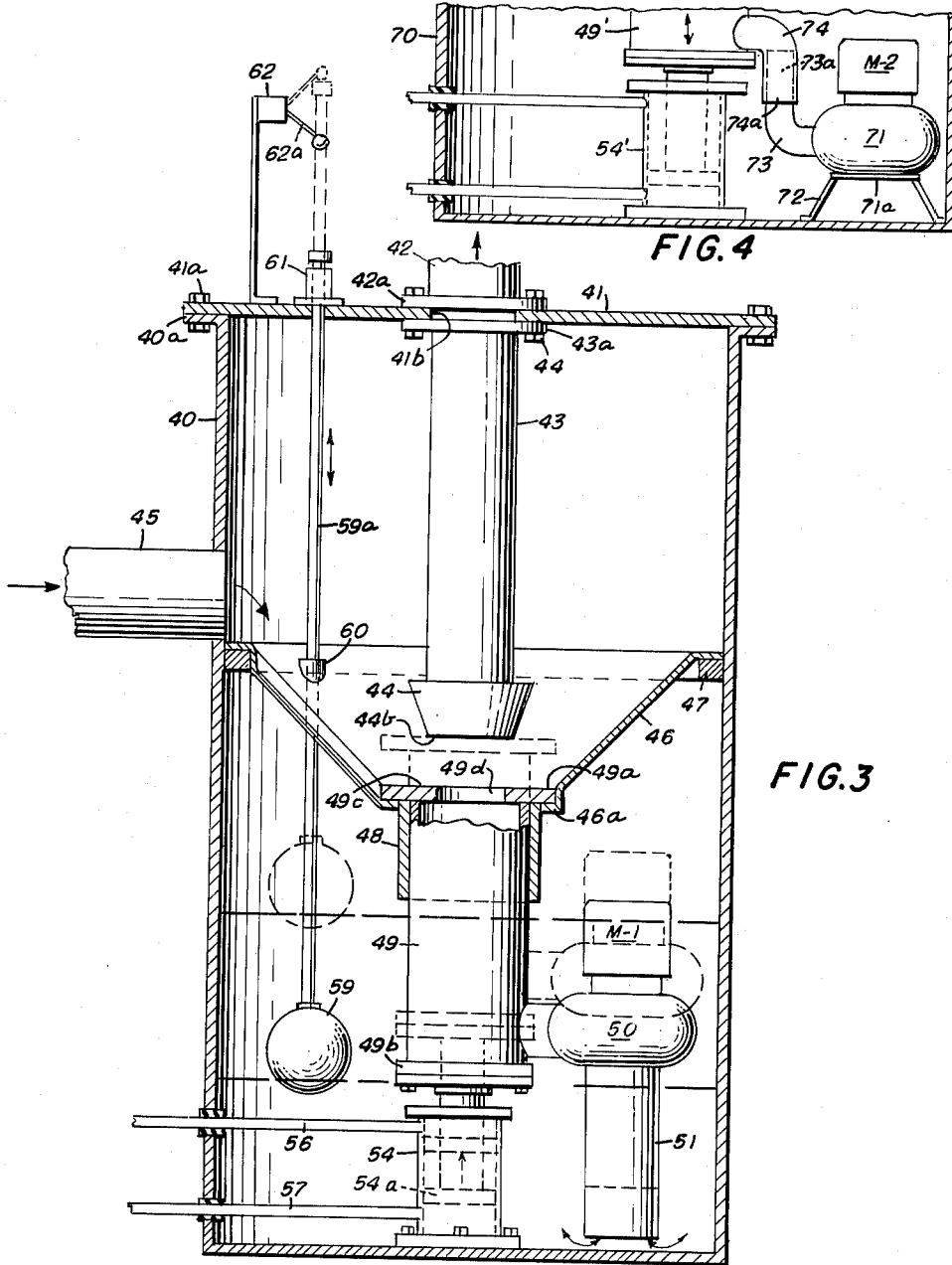

FIG. 4

FIG. 3

INVENTOR  
LYLE F. HOWE

BY *Beale and Jones*  
ATTORNEYS

1

2

3,233,549  
**STRAINING, COLLECTING AND PUMPING  
 SYSTEM**

Lyle F. Howe, Chevy Chase, Md.  
 (2423 Jackson Parkway, Vienna, Va. 22180)  
 Filed Apr. 22, 1963, Ser. No. 274,699  
 10 Claims. (Cl. 103-26)

This invention relates to improvements in pumping apparatus for liquid.

It is an object of my invention to provide pumping apparatus wherein material such as sewerage, industrial waste or any liquid that may include entrained solids is collected and periodically pumped from the collecting receptacle.

Another object of my invention is to provide in such pumping apparatus that has a filling line for a receptacle, a pump in the receptacle, a common first discharge line connected to the pump and receiving liquid from the filling line to transfer it to the receptacle, a second discharge line with apparatus to periodically connect it with the first discharge line to the exclusion of receiving liquid from the filling line so as to pump liquid out of the receptacle.

A further object of the invention is to provide an apparatus for collecting liquids such as waste wherein the collecting receptacle has a pump in the bottom thereof with a collecting strainer for admittance of fluids there-through and wherein is provided a discharge line from the receptacle having means to connect it periodically to the discharge of the pump to empty the collected fluids.

A still further object of the invention is to provide pumping apparatus for collecting fluids having entrained solid matter and to periodically connect the discharge of the pump to a discharge line and to include a cutting means for the solids on the edge of the connecting apparatus in the discharge line.

Still further objects and the entire scope of applicability of the present invention will become apparent from the detailed description given hereinafter. It should be understood, however, that the detailed description and specific examples are given by way of illustration only and, while indicating preferred embodiments of the invention, are not given by way of limitation since various changes and modifications within the spirit and scope of the invention will become apparent to those skilled in the art from this detailed description.

For a more complete understanding of the nature and scope of this invention, reference is had to the drawings in which:

FIG. 1 is a partial vertical sectional view of the apparatus;

FIG. 2 is a plan view of the collecting cone or basin in FIG. 1 on a reduced scale;

FIG. 3 is a partial vertical sectional view of a modified form of the apparatus; and

FIG. 4 is a fragmentary view of a further modification of the apparatus.

Throughout the description like reference numbers refer to similar parts.

The collecting apparatus is generally indicated at 10 such as in FIG. 1 and, for illustration, comprises a cylindrical metallic collecting receptacle 11 having a flanged

upper end 12 and a top flange cover 13 suitably secured thereto as by cap screws 13a.

The receptacle 11 serves as a collecting receptacle or pit for liquid from a liquid supply such as sewerage lines such as 14 and 15 and the like as are in hotels, apartment houses, etc. These lines 14 and 15 are connected in spaced relation down from the top of the receptacle in selected position to fit the surroundings. Such supply lines 14 and 15 may be connected through flanges 14a and 15a to connecting lines 14b and 15b welded or otherwise secured in the walls of the receptacle 11. The liquid supply will contain solid material such as rags, waste paper and other solids and the liquid containing these entrained articles passes through a conical shaped directing basin 16.

The conical shaped collecting basin or pan 16 is positioned within the receptacle and may be held in place by an annular boss 17 attached to the inside wall of receptacle 11 so as to position the collecting pan 16 just below the supply inlets 14b and 15b. This collecting pan 16 may be formed with inset trough portions 16a and 16b respectively under the inlets 14b and 15b so as to direct the collected material towards the center of the cone shape of the basin. It is formed with a central inverted cone portion 16c which is provided with a central aperture through which extends a float rod to be described. There is formed in the bottom of the cone 16 two apertures 16d having horizontal flanges as indicated at 16e.

Connected to the basin 16 at the apertures 16d in a depending manner are housings generally indicated at 18. Each housing 18 has a top flange 18a secured in 16e and a bottom flange 18b. The housing 18 may be of elongated cylindrical shape, as here shown, to serve as a filling and discharge pipe leading away from the discharge side of the pump to be described. Since each of the pumps and discharge pipe are alike only one will be described. The flange top 18a has a central aperture 18c therein and a suitable strainer 19 is housed within to collect any solids. The strainer or trap 19 may be of a type such as shown in Lannert U.S. Patent 2,278,178, issued Mar. 31, 1942. This strainer forms no part of the invention and various types of restraining apparatus may be provided to collect the solid materials and prevent them from entering the pump housing. Connected to the lower flange 18b of the discharge pipe 18 is the discharge of a pump such as of the centrifugal or vane type generally indicated at 20. The connection is through an elbow and flange coupling 21. Pump 20 is supported on feet 22 to space it from the bottom of the receptacle 11 and it has a bottom suction entrance as indicated at 20a. A suitable waterproof electric motor M is connected to the top of the centrifugal pump to provide power thereto for rotating same.

Thus, fluid supply is collected in the receptacle 11 up to say a water level as indicated at 22b. This raises a float 23 having a float rod 23a extending up through a central aperture 16c' in 16c and a flange 24 in the top 12 at a position to operate a starter switch 25 which is connected in a suitable control circuit for alternately operating the motors of the two pumps to provide for periodic separate operations and also to provide for operation of a servo motor such as an air or hydraulic cylin-

der or a solenoid as will be described. The control circuit and features form no part of the invention and are not shown.

Assuming that the pump 20 has been started, it discharges upward through the discharge pipe 18 which has been coupled to a second discharge pipe arrangement generally indicated at 26. This second discharge pipe 26 consists of a pipe 27 having an upper flange 27a connected to the cover 12 at an aperture wherein a further outside discharge pipe 28 is connected at its flange 28a. Other types of conventional connections could be used. Cooperating with the pipe 27 in a telescopic manner is a section of pipe 29. Other types of suitable connecting means such as bellows, flexible connections and the like could be used. This telescopic section of pipe 29 has a bottom end attachment 30 having an annular conical shaped arrangement which is threadedly attached to the pipe 29 as at 30a and provided with a bottom annular knife edge at 30b to cooperate with the flange 18a about the aperture 18c therethrough and to sever and cut in two any rags or objects that might obstruct. Thus, there is provided a direct connection at the discharge of first pipe 18 with the second discharge pipe 27 through the telescopic pipe connection 29. Movement of the pipe connection 29 may be accomplished through an arm 31b supported on a fulcrum 31, depending from the cover 13, as at pivot point 31a and further through a connecting rod 32 of a servo motor 33 having a piston 32a therein. The lower end of rod 32 has a bifurcated connection 32b that connects to the outer end of lever 30 as by a pivot pin 32c. Servo motor 33 has fluid operating lines at the end thereof as at 33a and 33b connected to a fluid system which is in turn activated through action of the switch 25 and in turn by the float 23. When the float 23 has risen to the upper level 22b, for example, the servo motor is actuated through fluid supplied at 33b so as to force the piston 32a upward and in turn to cause the telescopic pipe 29 to move down into contact with the flange 18a as indicated with a broken line. As the pumping continues and when the lower level is reached at 22a, the float 23 operates switch 25 to stop the motor and to cause the fluid for the servo motor to enter at 33a and force the piston 32a downward and in turn move up the telescopic section of pipe 29 so that fluid supply may again flow down through strainer 19 and the first discharge pipe 18 as described above.

During the pumping which is for a relatively few minutes, fluid supply collects in basin 16 as may be necessary and then is drained down into the bottom of the receptacle 11 in the usual manner as soon as the telescopic pipe moves upward.

It will be noted that the basin 16 acts as a transfer trough for the supply liquid flowing from pipe 15 to the first discharge pipe or housing 18. Also it will be noted that the pumps 20 are of a type that permits reverse flow therethrough and thus the supply liquid from sewer lines 14 and 15 run down through the first discharge pipe 18 and the housing of the pump on through its inlet 20a to be collected in receptacle 11.

When the telescope section 29 of the second discharge pipe is connected to the first discharge pipe 18 supply fluid flow is excluded from entering the first discharge pipe 18.

Through this arrangement of fluid pumping apparatus a very reliable system is provided. If necessary in the control of the motors and suitable actuating mechanism which is identical for the two systems shown in FIG. 1, if necessary both motors could be operated simultaneously but it is preferred that they operate alternately. So also if one motor failed to operate for its turn of pumping, suitable control apparatus could be provided to actuate the other motor.

An alternate form is illustrated in FIG. 3 wherein a single pump is illustrated and the arrangement is to move

the pump with its discharge line upward to engagement with a second discharge pipe as will be described.

A receptacle 40 of the cylindrical type, such as illustrated in FIG. 1 and previously described, is provided with a top flange portion 40a and a cover 41 which is removable as by the cap screws 41a. The cover 41 has a central aperture 41b. Attached to the outside of the cover 41 is a discharge pipe 42 having flanges 42a. Within the inside of the cover 41 is a discharge pipe portion 43 with a flange 43a connected to the cover and to the other flange 42a as by bolts 44. The lower end of discharge pipe 43 has a fitting 44 similar to the wedge shaped fitting 30 in FIG. 1, previously described. Fitting 44 also has a lower knife edge 44b for cutting obstructing solids.

Liquid supply to the receptacle 40 is through a supply line 45 in a similar manner as before for the receptacle 11. A conical pan or basin 46 is supported within the receptacle 40 at a position just below the fluid entrance 45 as by annular flange 47 on the inside wall of the receptacle. The central portion of the pan 46 is formed with an aperture and a flange as indicated at 46a. Secured within this flange 46a as by welding is a depending collar 48 which provides a guide and throat for a first discharge pipe 49 having a trap which is similar to the discharge pipe 18 and described heretofore in FIG. 1. This discharge pipe 49 has a flanged upper end 49a and a bottom flanged end 49b. A suitable strainer such as 19 in the apparatus at FIG. 1 is also provided herein within discharge pipe 49. The upper flange 49a has a radially inwardly direct portion 49c which forms an aperture 49d. The portion 49c serves as a bed to cooperate with the knife edge 44b on fitting 44 on the second discharge pipe 43 when the pipe 49 is moved up into broken line position for contact therewith. This position is for discharge of fluid in the pumping operation to empty the receptacle 40.

Connected to the first discharge pipe 49 is a pump 50 which is similar to the type of FIG. 1 having a suction entrance at 51 and driven by a motor M-1 which is fluid tight as described before.

A float 59 having a float rod 59a extends up through the collecting pan 46 as at 60 and on up through the cover 41 to a flanged bushing 61 to operate a switch 62 having an arm 62a connected with the rod at its upper end. The switch 62 serves to cut on and off the motor M and also to control the direction of flow of fluid through the lines 56 and 57 to supply the servo motor 54. Thus, when the water level reaches the upper level the float rises, starts motor M-1, causes fluid to be applied through the line 57 to the servo motor 54 whereupon the piston 54a thereof moves upward to move the discharge pipe 49 along with the pump 50 and its motor M-1 upward to the broken line position. The telescopic action of the discharge pipe 49 within the guide sleeve 48 cuts off flow of the supply fluid normal flow to the pipe 49 and it now collects in the pan 46. Any obstruction such as rags and pieces of paper or collected articles are severed between the cutter blade 44b and the flange 49a. When the float 59 reaches its low position the motor M-1 is cut off and the servo motor is operated by a supply fluid through line 56 to move the piston 54a down and to move the first discharge pipe 49 down to its full line position whereupon fluid is again admitted downward through the pipe 49 and strainer therein so as to be collected in the receptacle 40.

Another modified form of apparatus is shown in the fragmentary view in FIG. 4. A receptacle 70 similar to receptacle 40 is used in this apparatus along with a similar servo motor 54' and a similar reciprocally mounted first discharge pipe or housing 49' to that shown for the pumping apparatus in FIG. 3 is also used. A pump 71 is mounted in the bottom of receptacle 70 and has supports 72 and a bottom suction 71a in communication with receptacle 70 and is similar to the pumps 20 shown

in FIG. 1. A motor M-2 is mounted on the top of the pump 71 to drive the same. This pump 71 as the other similar pumps 20 and 50 is of a type permitting reverse flow downward therethrough when not in operation. A discharge pipe 73 in the form of an elbow with an up-standing end 73a is attached to the discharge side of pump 71. A connecting elbow 74 is attached to the bottom side wall of discharge pipe 49' and the end of elbow 74 at 74a extends downward and is received over the end 73a of elbow 73 in a telescopic manner to provide a movable connection between stationary positioned pump 71 and discharge pipe 49'. Thus, as in the operation of the apparatus in FIG. 3, the first discharge pipe 49' is moved up and down to connect with a similar discharge pipe 43 for pumping and for filling of the receptacle.

While a single pump has been illustrated in the arrangement of the apparatus in FIGS. 3 and 4, two or more pumps with cooperating structure could equally as well be employed.

The term liquid herein used also may include entrained solids or semi-solids of any type.

In the operation of pumping in all of the forms, the trapped solids are carried out the discharge pipes 29 and 43 when pumping of the receptacles occurs and the strainers are thus periodically cleared of trapped material.

There is herein provided by this improved straining, collecting and pumping equipment a very reliable and rugged system and apparatus.

I claim as my invention:

1. Pumping apparatus comprising in combination a liquid receiving receptacle, an inlet conduit connected to discharge into said receptacle and adapted to be connected with a source of liquid supply, a pump in said receptacle having an inlet side connected to draw fluid from said receptacle, a first discharge pipe connected to the discharge side of the pump, liquid transfer means in said receptacle disposed between said inlet conduit and said first discharge pipe, said first discharge pipe having strainer means therein for collecting solids from supply liquid passing down therethrough, said pump having means permitting reverse flow therethrough whereby fluid from the inlet conduit passes through said liquid transfer means and said first discharge pipe for collection in said receptacle, a second discharge pipe extending into said receptacle and adapted to lead therefrom for receiving liquid from said first discharge pipe, movable connecting means disposed in said receptacle for causing said first and second discharge pipes to be connected and cutting off flow from said liquid transfer means to said first discharge pipe during removal of liquid from said receptacle by said pump, and means responsive to the liquid level in said receptacle for actuation and deactuation of said pump and for causing said first and second discharge pipes to be connected and disconnected respectively by said movable connecting means.

2. Pumping apparatus according to claim 1 wherein said movable connecting means for causing said first and second discharge pipes to be connected comprises a telescopic section of pipe on said second discharge pipe.

3. Pumping apparatus according to claim 1 wherein said movable connecting means for causing said first and second discharge pipes to be connected comprises said first discharge pipe having movable mounting means for moving said first discharge pipe into and out of telescopic connection with said second discharge pipe.

4. Pumping apparatus comprising in combination a liquid receiving receptacle, an inlet conduit connected to discharge into said receptacle and adapted to be connected with a source of liquid supply, a pump in said receptacle having an inlet side connected to draw fluid from said receptacle and a discharge side and means permitting reverse flow therethrough, a first discharge pipe in said receptacle connected to the discharge side of the pump, liquid transfer means in said receptacle disposed between said inlet conduit and said first discharge pipe for transfer

of supply liquid from said inlet conduit to said first discharge pipe, said first discharge pipe having movable pipe means connecting the lower portion of said first discharge pipe with the discharge side of said pump for permitting relative movement between the pump and the first discharge pipe, said first discharge pipe having strainer means for collecting solids from supply liquid passing down therethrough, a second discharge pipe extending into said receptacle and adapted to lead therefrom for receiving liquid from said first discharge pipe, said first discharge pipe having movable mounting means for moving the first discharge pipe into fluid transfer relation to said second discharge pipe for transfer of fluid therethrough pumped by said pump that has collected in said receptacle, and cutting off flow from said liquid transfer means to said first discharge pipe during removal of liquid from said receptacle by said pump, and means responsive to the liquid level in said receptacle for actuation and deactuation of said pump and for causing said first and second discharge pipes to be moved into and out of fluid transfer relation respectively by said movable mounting means for the first discharge pipe.

5. Pumping apparatus according to claim 4 including obstruction cutting means on said second discharge pipe and said first discharge pipe for cutting obstructions lodging therebetween.

6. Pumping apparatus according to claim 4 wherein said liquid transfer means disposed between said inlet conduit and said first discharge pipe for transfer of supply liquid therethrough comprises a conical-like basin supported at its periphery by the wall of said receptacle and having a bottom opening having a telescopic connection means with said first discharge pipe.

7. Pumping apparatus according to claim 1 including obstruction cutting means for cutting obstructions lodging between said first and second discharge pipes.

8. Pumping apparatus comprising in combination a liquid receiving receptacle, an inlet conduit connected to discharge into said receptacle and adapted to be connected with a source of liquid supply, a pump in said receptacle having an inlet side connected to draw fluid from said receptacle, a first discharge pipe, connected to the discharge side of the pump, liquid transfer means in said receptacle disposed between said inlet conduit and said first discharge pipe for transfer of liquids to and through the first discharge pipe and the pump for collection in said receptacle, strainer means associated with said first discharge pipe for collecting solids from supply liquid passing down therethrough, said first discharge pipe having movable connection means associated with said liquid transfer means, a second discharge pipe extending into said receptacle and adapted to lead therefrom for receiving liquid from said first discharge pipe when pumped up therethrough by the pump from the receptacle, means disposed in said receptacle for moving said first discharge pipe and pump for connecting and disconnecting said first discharge pipe to said second discharge pipe and cutting off flow from the liquid transfer means to said first discharge pipe during removal of liquid from said receptacle by said pump, and means responsive to the liquid level in said receptacle for actuation and deactuation of said pump and for causing said first and second discharge pipes to be connected and disconnected respectively by said means for moving said first discharge pipe and pump.

9. A pumping apparatus according to claim 8 having cutting means on the first discharge pipe and the second discharge pipe for cutting solids lodging therebetween.

10. Pumping apparatus comprising in combination a liquid receiving receptacle, an inlet conduit connected to discharge into said receptacle and adapted to be connected with a source of liquid supply, a pump in said receptacle having an inlet side connected to draw fluid from said receptacle, a first discharge pipe connected to the discharge side of the pump, liquid transfer means in

7

said receptacle disposed between said inlet conduit and said first discharge pipe for transfer of liquids to said first discharge pipe to be collected in said receptacle, said first discharge pipe having strainer means therein for collecting solids from supply liquid passing down there-  
 5 through, a second discharge pipe extending into said receptacle and adapted to lead therefrom for receiving liquid from said first discharge pipe, and movable means disposed in said receptacle for causing said first and second discharge pipes to be connected and cutting off flow  
 10 from said liquid transfer means to said first discharge pipe during removal of liquid from said receptacle by said pump, and means responsive to the liquid level in said receptacle for actuation and deactuation of said

8

pump and for causing said first and second discharge pipes to be connected and disconnected respectively by said movable means.

## References Cited by the Examiner

## UNITED STATES PATENTS

925,242	6/1909	Steinwand	-----	285—302
2,445,505	7/1948	Ashton	-----	137—528 X
2,563,862	8/1951	Nechine.		
3,032,194	5/1962	Evans et al.	-----	209—158

REUBEN FRIEDMAN, *Primary Examiner.*FRANK W. LUTTER, *Examiner.*