

[54] **FIRE AND SMOKE VENTILATOR**  
 [75] Inventor: **Arthur P. Jentoft, York, Maine**  
 [73] Assignee: **Wasco Products Inc., Sanford, Maine**  
 [22] Filed: **Nov. 24, 1971**  
 [21] Appl. No.: **201,934**

[52] U.S. Cl. .... **98/86, 49/4, 137/72**  
 [51] Int. Cl. .... **F24f 7/02**  
 [58] Field of Search ..... **98/86; 49/1, 3, 4, 49/5, 6, 7, 8, 31; 137/72; 220/89 B**

[56] **References Cited**  
**UNITED STATES PATENTS**

2,766,859	10/1956	Urquhart .....	49/7
3,036,406	5/1962	Wasserman .....	98/86 X
3,516,197	6/1970	Lyons .....	98/86 X
3,557,497	1/1971	Schafer et al. ....	49/7 X
3,596,586	8/1971	Krannich .....	98/86

*Primary Examiner*—William F. O'Dea  
*Assistant Examiner*—Peter D. Ferguson  
*Attorney*—Wolf, Greenfield & Sacks

[57] **ABSTRACT**

A roof mounted fire and smoke ventilator includes a simplified mechanism for maintaining the cover closed and which also serves as a snubbing device to cushion the opening shock of the cover when the vent snaps open. The mechanism includes a simple arrangement of cables which are connected between the curb of the vent and the free end of the cover. The cover is spring biased toward an open position but is held closed by the cables by an arrangement including a fusible link which, when melted, releases the cables and enables the vent cover to snap open. Means also are provided to release the cables without destroying the fusible link, as might be desired when testing the operation of the vent.

**9 Claims, 5 Drawing Figures**

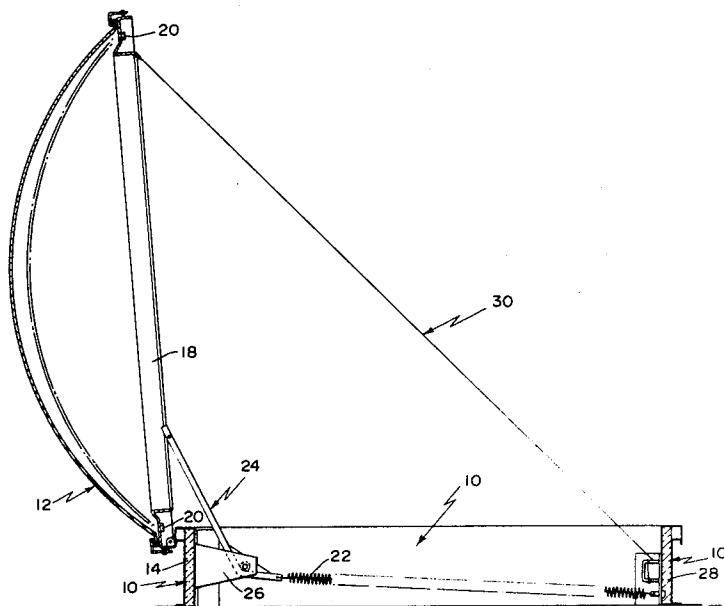

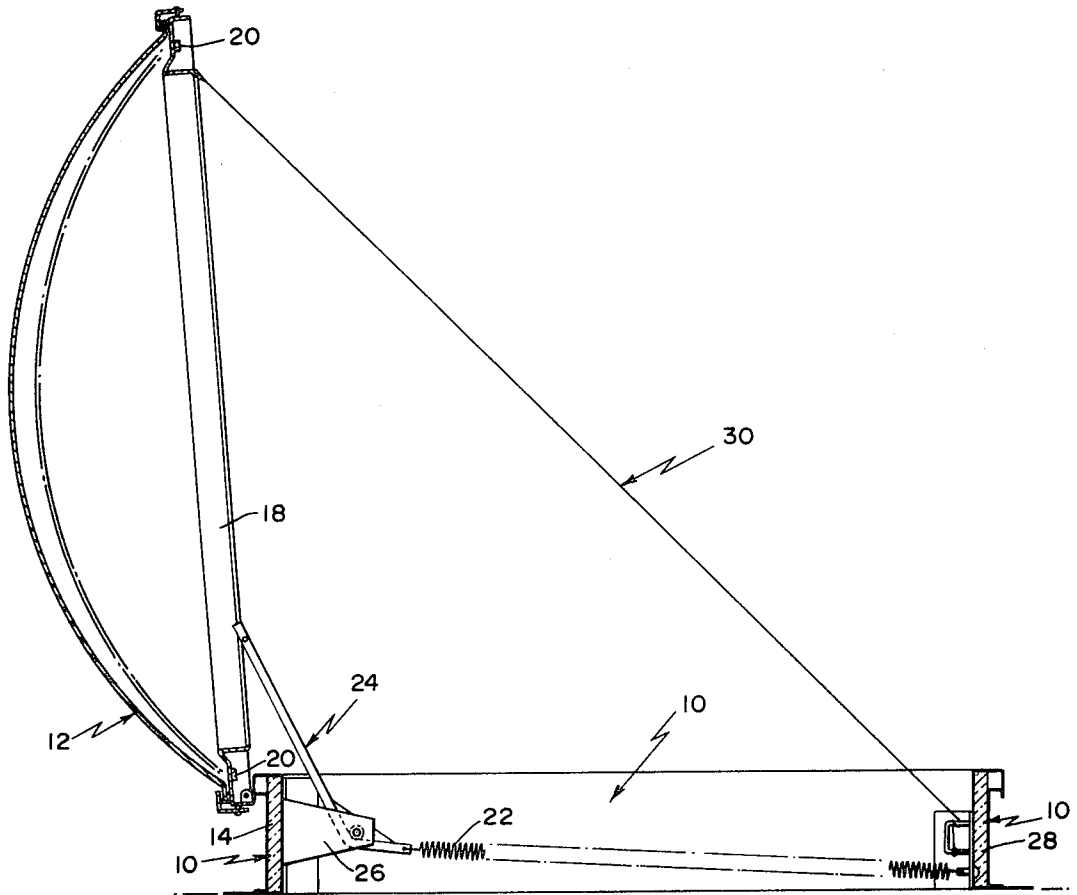

FIG. 1

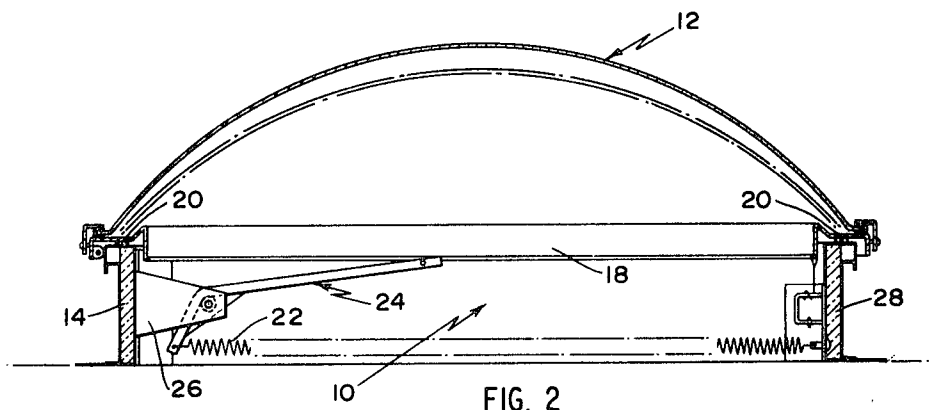

FIG. 2

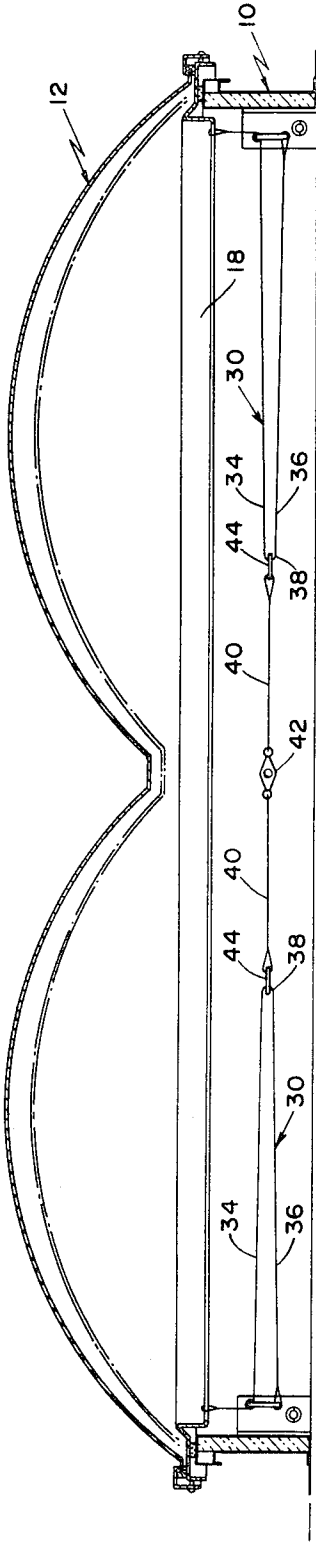

FIG. 3

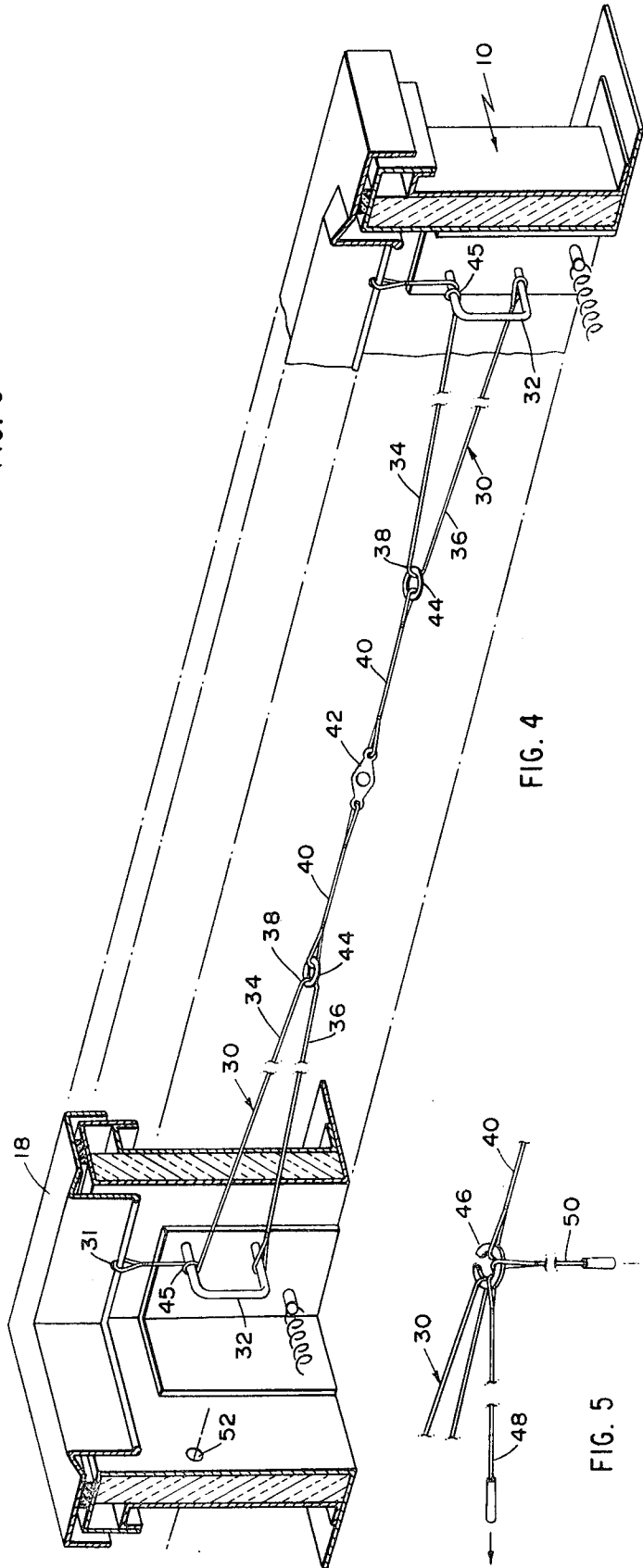

FIG. 4

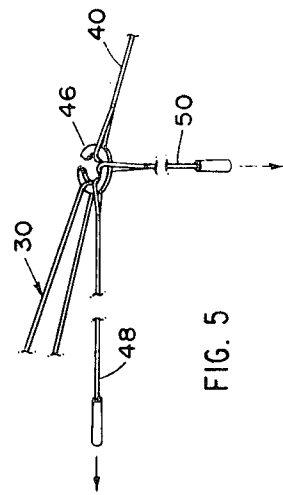

FIG. 5

## FIRE AND SMOKE VENTILATOR

### BACKGROUND OF THE INVENTION

This invention relates to an improved simplified mechanism usable in a fire and smoke vent.

The invention is intended to avoid some of the more complicated locking and releasing arrangements commonly found in such vents.

### SUMMARY OF THE INVENTION

The invention is employed in a conventional roof venting arrangement having a curb which frames the roof opening and a cover pivotally mounted to the curb along an edge thereof. The cover is biased about the hinge toward an open position by means of a spring and lever arrangement. A cable is connected between the free end of the cover and the curb, there being, in the preferred arrangement, a pair of such cables, one each being disposed at the forward free corners of the cover. The cables are of a length so that when the cover has snapped open, the cables permit the cover to open at least 90° and, preferably, slightly more, as of the order of approximately 95°. When the cover is in the closed position, the cables are drawn, at their mid portions, toward each other along the forward side of the curb. The cables thus are arranged to define a pair of adjacent bights. The bight portion of the cable are connected by a fusible link.

In a preferred embodiment of the invention, means are provided for freeing the bights of the cables from each other without destroying the fusible link to release the vent cover as when testing the device. This arrangement employs a temporary manually releasable connector between the fusible link and one of the cable bights. A further aspect of the invention concerns the substantial aerodynamic lifting force on the cover due to its exposure to the wind. The double reeving of the cable and, where necessary, the rapping of the cable around the cable end attachments, minimize the possibility that any excessive wind forces might exceed the load capacity of the fusible link, thus destroying the link and releasing the cover inadvertently.

It is among the primary objects of the invention to provide a simplified mechanism for locking and releasing a cover for a vent of the general type described.

### DESCRIPTION OF THE DRAWINGS

The foregoing and other objects and advantages of the invention will be understood more fully from the following detailed description thereof with reference to the accompanying drawings wherein:

FIG. 1 is an illustration, in sections, of the roof vent in an open position;

FIG. 2 is a side elevation of the vent in a closed position;

FIG. 3 is a section taken through the closed vent along the lines 3—3 of FIG. 2;

FIG. 4 is an enlarged illustration of the cable release mechanism; and

FIG. 5 is an illustration of a manually operable release mechanism.

### DESCRIPTION OF THE PREFERRED EMBODIMENT

As shown in the drawings the vent includes the usual curb 10 which is secured to the roof and extends upwardly therefrom to define the vent passage. The curb

may be fabricated according to well known techniques and, for example, may include an inner and outer aluminum skin with internal insulative material such as fiber glass or the like. A vent cover 12 is hinged to and along the rear wall 14 of the curb. The roof cover may be formed in any of a number of configurations. In the illustrative embodiment, the roof cover comprises a double dome bubble cover which may be formed from an appropriate plastic material. The cover includes a frame 18 which extends about and engages the upper region of the curb 10. Appropriate seals 20 preferably are provided.

The invention relates to a simplified arrangement for locking and releasing the cover. As shown in the drawings, the cover 12 is biased toward an open position by a pair of springs 22 and lift arms 24. The lift arms are pivotally mounted to brackets 26 which are secured to the inner rear wall 14 of the curb 10. The lift arms 24 include a forwardly extending end which bears upwardly against the inner surface of the cover frame 18. The other end of the lift arms 24 are connected to the rear end of the springs 22. The forward end of the springs are connected to the front wall 28 of the curb 10. With this arrangement, the springs and lift arms bias the vent cover 12 toward an open position.

In order to maintain the vent cover 12 in its normally closed position, the vent is provided with a pair of cables 30. Each cable is connected at one end to the inner surface of the front wall 28 as by a U-bolt 32 secured to the front wall. The other end of each cable 30 is connected to the forward portion of the cover frame 18 as shown at 31. When the vent cover 12 is released and snaps toward its open position, the extent of its open position will be determined by the length of the cables 30. In the preferred embodiment, the length of the cables is selected so that the cover will open to at least 90° and, preferably, slightly more in the order of approximately 95°.

When the cover is closed, as shown in FIGS. 2 and 3, each of the cables 30 is drawn and retained at approximately its mid portion inwardly toward each other so that each cable defines a generally U-shaped configuration having upper and lower runs 34, 36 and a bight 38. The bights 38 are connected to each other to retain to cover in a closed position by means of cables 40 which are connected to each other by a fusible link 42. The outer ends of the cables 40 are connected to the lights 38 of their respective cables 30 by flat washers 44 or other appropriate connections. When the device operates automatically as a fire and smoke safety vent, the fusible link melts when subjected to a predetermined temperature (for example, 165° F) thus releasing the cables 30 and enabling the spring biased lift arms 24 to raise the vent cover 12. The vent cover will open until the cables 30 are drawn taught as shown in FIG. 1.

There will be instances in which the wind, flowing over the cover, will generate an aerodynamic force tending to raise the cover 12. This force may at times be substantial and it is desirable to isolate this lifting force from the fusible link so that the link 42 is not inadvertently snapped in the absence of fire. For this purpose means are provided so that the aerodynamic lift which may be developed at the cover 12 is taken up by the portion of the cable 30 and not by the fusible link 42. In the illustrative embodiment, this arrangement takes an extremely simple, yet effective configuration: As shown, the upper strand 34 of each cable 30 is wrapped

about the upper leg of its associated U-bolt 32, as shown at 45, and then is connected to the front edge of the vent cover frame 18. This wrapped arrangement for the cable provides a sufficient frictional grip about the U-bolt so that any upward lifting tendency of the cover 16 will be taken up within the cable itself and will not be transmitted to the fusible link 42.

The preferred embodiment of the invention also includes means, shown in FIG. 5, to release the cable arrangement to open the cover without destroying the fusible link 42. For this purpose, one of the washers 44 which connects the bights 38 with the cables 40 is of a split or C-ring configuration as shown at 46. One of the cables 30 is looped about the washer 46 and the associated link cable 40 also is looped about the other end of the washer. Additional release cables 48, 50 are connected to the C-ring 46 so that if either cable 48, 50 is pulled it will tend to draw the C-ring out of engagement with the bight 38 or cable 40 thus releasing the inward restraint on the cables 30. One of the release cables, 48 may extend through the curb wall to provide an outside accessible release, or through the hole 52. The other cable, 50, may extend downwardly within the curb to provide an interior release. If desired, the interior release cable may be connected to a solenoid to enable electrical operation of the manual release mechanism.

Thus, I have described a simplified arrangement for retaining a fire and smoke ventilator cover closed but in readiness to open automatically in response to a fire. The device avoids use of the normally encountered complex latching mechanisms. It should be understood, however, that the foregoing description of the invention is intended merely to be illustrative thereof and that other embodiments and modifications may be apparent to those skilled in the art without departing from its spirit.

Having thus described the invention what I desire to claim and secure by Letters Patent is:

1. In a building vent having a curb and a cover hinged to the curb, a device for releasably constraining said cover in a closed position comprising:

- at least one main cable connected at one end to a free unhinged portion of said cover and at the other end to said curb wall, said cable being of a length and being so arranged as to restrain said cover from opening beyond a predetermined position;
- means biasing said cover toward said open position;
- means for engaging said main cable when said cover is closed to take up the slack in said cable and to maintain said cable taut to thereby retain said cover in said closed position; and
- means for releasing said cable engaging means to enable said cover to spring toward said open position, the extent of said open position being determined by the length of said main cable.

2. A device as defined in claim 1 wherein said means for engaging said main cable comprises:

- means engaging said main cable between its ends to restrain at least a portion of said cable in a substantially U-shaped configuration.

3. A device as defined in claim 2 wherein said building vent comprises a fire and smoke vent wherein said means for releasing said cable engaging means comprises:

- said means engaging said cable between said ends thereof including a fusible link.

4. A device as defined in claim 2 further comprising: said vent including two such cables, disposed on opposite lateral sides of said vent, each of said cables being constrained so that when in said U-shaped configuration, their bights extend toward each other, said means for engaging said main cable comprising:

- a connective member connected at its ends to said bights of said main cable, said connective member including said fusible link between its ends.

5. A device as defined in claim 4 wherein said connective member comprises a connective cable, said device further comprising:

- one of said bights being connected to its associated end of said connective cable by a split ring; and
- release cable means connected to said split ring to effect withdrawal of said split ring from engagement of either of said bight or said connective cable when said release cable is pulled.

6. A device as defined in claim 5 wherein said means for restraining said cable in said U-shaped configuration comprises:

- means for releasing manually said connective cable from said main cables comprising:
- one of said bights being connected to its associated end of said connective cable by a split ring; and
- release cable means connected to said split ring to effect withdrawal of said split ring from engagement of either of said bight or said connective cable when said release cable is pulled.

7. A device as defined in claim 4 further comprising: means isolating aerodynamically generated forces tending to lift said dome from said fusible link.

8. A device as defined in claim 7 wherein said means for isolating said aerodynamic lifting forces from said fusible link comprises:

- means confining said forces to said main cable.

9. A device as defined in claim 8 wherein said means for confining said forces to said main cable comprises: said portion of said main cable between said bight thereof and said cover being wrapped about a member to engage frictionally said member, and means mounting said member to said curb.

\* \* \* \* \*