

(19) World Intellectual Property Organization
International Bureau



(43) International Publication Date
4 October 2001 (04.10.2001)

PCT

(10) International Publication Number
WO 01/73929 A2

(51) International Patent Classification⁷: H02M 3/158

(21) International Application Number: PCT/US01/01955

(22) International Filing Date: 18 January 2001 (18.01.2001)

(25) Filing Language: English

(26) Publication Language: English

(30) Priority Data:
09/484,600 18 January 2000 (18.01.2000) US

(71) Applicant: FORMFACTOR, INC. [US/US]; 5666 La Ribera Street, Livermore, CA 94550 (US).

(72) Inventors: ELDRIDGE, Benjamin, N.; 651 Sheri Lane, Danville, CA 94526 (US). MILLER, Charles, A.; 48881 Semillon Drive, Fremont, CA 94539 (US).

(74) Agents: MERKADEAU, Stuart, L. et al.; Formfactor, Inc., 5666 La Ribera Street, Livermore, CA 94550 (US).

(81) Designated States (*national*): AE, AG, AL, AM, AT, AU, AZ, BA, BB, BG, BR, BY, BZ, CA, CH, CN, CR, CU, CZ, DE, DK, DM, DZ, EE, ES, FI, GB, GD, GE, GH, GM, HR, HU, ID, IL, IN, IS, JP, KE, KG, KP, KR, KZ, LC, LK, LR, LS, LT, LU, LV, MA, MD, MG, MK, MN, MW, MX, MZ, NO, NZ, PL, PT, RO, RU, SD, SE, SG, SI, SK, SL, TJ, TM, TR, TT, TZ, UA, UG, UZ, VN, YU, ZA, ZW.

(84) Designated States (*regional*): ARIPO patent (GH, GM, KE, LS, MW, MZ, SD, SL, SZ, TZ, UG, ZW), Eurasian patent (AM, AZ, BY, KG, KZ, MD, RU, TJ, TM), European patent (AT, BE, CH, CY, DE, DK, ES, FI, FR, GB, GR, IE, IT, LU, MC, NL, PT, SE, TR), OAPI patent (BF, BJ, CF, CG, CI, CM, GA, GN, GW, ML, MR, NE, SN, TD, TG).

Published:

— without international search report and to be republished upon receipt of that report

For two-letter codes and other abbreviations, refer to the "Guidance Notes on Codes and Abbreviations" appearing at the beginning of each regular issue of the PCT Gazette.

(54) Title: APPARATUS FOR REDUCING POWER SUPPLY NOISE IN AN INTEGRATED CIRCUIT

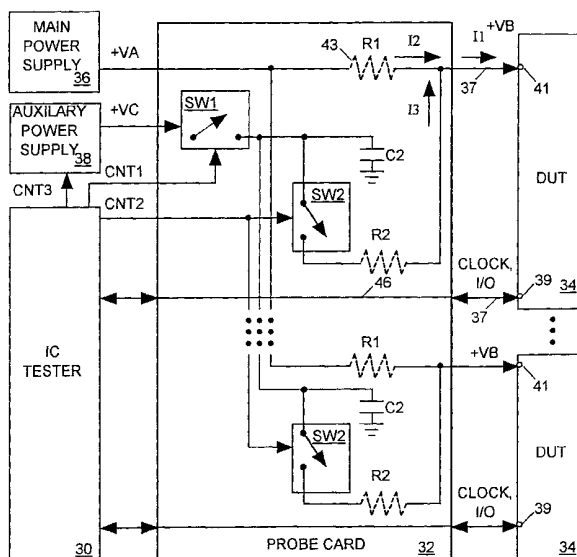

(57) Abstract: A main power supply continuously provides a current to a power input terminal of an integrated circuit device under test (DUT). The DUT's demand for current at the power input terminal temporarily increases during state changes in synchronous logic circuits implemented within the DUT. To limit variation (noise) in voltage at the power input terminal arising from these temporary increases in current demand, a charged capacitor is connected to the power input terminal during each DUT state change. The capacitor discharges into the power input terminal to supply additional current to meet the DUT's increased demand. Following each DUT state change the capacitor is disconnected from the power input terminal and charged to a level sufficient to meet a predicted increase in current demand during a next DUT state change.



WO 01/73929 A2

**APPARATUS FOR REDUCING POWER SUPPLY NOISE
IN AN INTEGRATED CIRCUIT**

BACKGROUND OF THE INVENTION

Field of the Invention

The present invention relates in general to systems for testing integrated circuits and in particular to an apparatus for reducing power supply noise in an integrated circuit under test resulting from state transitions of the logic it implements.

Description of Related Art

10 An integrated circuit (IC) tester can concurrently test a set of ICs in the form of die on a silicon wafer. FIG. 1 is a block diagram illustrating a typical IC tester 10 connected through a probe card 12 to a set of similar IC devices under test (DUTs) 14. Tester 10 uses pogo pins 15 or other means to connect various input and output terminals to a set of contacts 16 on probe card 12. Probe card 12 includes a set of probes 18 for contacting input/output (I/O) pads 19 on the surface of each DUT 14 and provides conductive paths 20 linking contacts 16 to probes 18. The paths through probe card 12 allow tester 10 to transmit test signals to DUT 14 and to monitor output signals produced by the DUT. Digital integrated circuits often include synchronous logic gates clocked in response to pulses of a periodic master clock signal (CLOCK). Therefore probe card 12 also provides a path 22 through which tester 10 may supply a CLOCK signal to each DUT 14. The test system also includes a power supply 24 for supplying power to DUTs 14 as they are being tested. Probe card 12 connects power supply 24 to a power input pad 26 of each DUT 14 through probes 18.

30 Each switching transistor within a DUT 14 has an inherent input capacitance, and in order to turn on or off the transistor, the transistor's driver must either charge or discharge the transistor's input capacitance. When a driver charges a transistor's input capacitance it draws charging current from power supply 24. Once the transistor's input capacitance is fully charged, its driver need only supply a

relatively small amount of leakage current needed to keep the transistor's input capacitance charged so that the transistor remains turned on or off. In DUTs implementing synchronous logic, most transistor switching occurs immediately after an edge of each CLOCK signal pulse. Thus immediately after each pulse of the CLOCK signal, there is a temporary increase in the power supply current I1 input to each DUT 14 to provide the charging current necessary to change the switching states of various transistors within the DUT. Later in the CLOCK signal cycle, after those transistors have changed state, the demand for power supply current I1 falls to a "quiescent" steady state level and remains there until the beginning of the next CLOCK signal cycle.

The signal paths 28 through which probe card 12 connects power supply 24 to each DUT 14 have an inherent impedance represented in FIG. 1 by a resistance R1. Since there is a voltage drop between the output of power supply 24 and the power input 26 of DUT 14, the supply voltage input VB to DUT 14 is somewhat less than the output voltage VA of power supply 24, and although VA may be well-regulated, VB varies with the magnitude of current I1. After the start of each CLOCK signal cycle, the temporary increase in I1 needed to charge switching transistor input capacitance increases the voltage drop across R1, thereby temporarily reducing VB. Since the dip in supply voltage VB occurring after each CLOCK signal pulse edge is a form of noise that can adversely affect the performance of DUTs 14, it is desirable to limit its magnitude and duration.

We can limit that noise by reducing the reactance of the paths 28 between power supply 24 and DUTs 14, for example by increasing conductor size or by minimizing the length of path 28. However there are practical limits to the amount by which we can reduce that reactance.

We can also reduce power supply noise by placing a capacitor C1 on probe card 12 near the power supply input 26 of each DUT 14. FIG. 2 illustrates the behavior of supply voltage VB and current I1 at the power input 26 of IC 14 in response to a pulse of the CLOCK signal input to IC 14 when capacitor C1 is insufficiently large. Note that the temporary rise in I1 above its quiescent level IQ following an edge of

the CLOCK signal at time T1 produces a temporary increase in voltage drop across R1 that in turn produces a temporary dip in supply voltage VC below its quiescent level VQ.

FIG. 3 illustrates the behavior of VB and I1 when
5 capacitor C1 is sufficiently large. Between CLOCK signal pulses, when DUT 14 is quiescent, capacitor C1 charges to the quiescent level VQ of VB. Following a rising (or falling) edge of the CLOCK signal at time T1, when a DUT 14 temporarily
10 demands more current, capacitor C1 supplies some its stored charge to DUT 14 thereby reducing the amount of additional current power supply 24 must provide to meet the increased demand. As may be seen in FIG. 3, the presence of C1 reduces the magnitude of the temporary voltage drop across R1 and therefore reduces the magnitude of the dip in the supply
15 voltage VB input to the DUT 14.

For capacitor C1 to adequately limit variation in VB, the capacitor must be large enough to supply the needed charge to DUT 14 and must be positioned close to DUT 14 so that the path impedance between C1 and DUT 14 is very low. Unfortunately it
20 is not always convenient or possible to mount a large capacitor on a probe card 12 near the power supply input terminal 26 of each DUT 14. FIG. 4 is a simplified plan view of a typical probe card 12. IC tester 10 resides above the probe card and the wafer containing DUTs 14 is held below the
25 probe card. Since the I/O terminals of IC tester 10 of FIG. 1 are distributed over a relatively large area compared to the surface area of the wafer being tested, probe card 12 provides a relatively large upper surface 25 for holding the contacts 16 the tester accesses. On the other hand, the probes 18 (not
30 shown) on the underside of probe card 12 that contact DUTs 14 on the wafer are concentrated under a relatively small central area 27 of probe card 12.

The path impedance between contacts 16 on the upper surface 25 of card 12 and the probes 18 under area 27 is a
35 function of the distance between each contact 16 and its corresponding probe. To minimize the distance between capacitors C1 and the DUTs, the capacitors should be mounted on probe card 12 near (or above) the small central area 27. However when a wafer includes a large number of ICs to be

tested or an IC having a large number of densely packed terminals, there is not enough space to mount the required number of capacitors C1 of sufficient size sufficiently close to central area 27.

5 What is needed is a system for limiting the switching noise in power supply voltage at the power input terminals of the DUTs that does not require mounting large capacitors on the probe card close to the probes accessing the power input terminals.

10

SUMMARY OF THE INVENTION

During a test of an integrated circuit device under test (DUT) employing synchronous logic, the DUT experiences a temporarily increase in its demand for power supply current after each pulse of a clock signal input to the DUT because each clock signal pulse initiates state transitions of clocked logic devices within the DUT. The DUT needs the extra current to charge input capacitance of transistors forming those logic devices. It is an object of the invention to provide a means for limiting variation in power supply voltage at the power input terminal of a DUT arising from the transient increase in power supply current following each clock signal pulse, thus reducing the power supply noise at the DUT.

In accordance with one aspect of the invention, a charging current is supplied to the DUT's power input terminal from an auxiliary power supply source after each clock signal pulse to supplement a current continuously supplied by a main power supply during the test. The additional charging current reduces the need for the main power supply to increase its output current to meet the DUT's increased demand. With the output current of the main power supply being held substantially constant despite the DUT's increased demand for current, any voltage drop across path impedance between the main power supply and the DUT remains substantially constant. Thus the supply voltage at the DUT's power input terminal remains substantially constant.

The amount of additional charging current a DUT requires after each clock signal pulse varies depending on the state transition its internal logic devices undergoes in response to

the clock signal pulse. In accordance with another aspect of the invention the additional charging current supplied is adjusted to match a predicted value of transient charging current required by the DUT following each clock signal pulse.

5 In accordance with a further aspect of the invention, in a preferred embodiment thereof, the auxiliary power source includes a capacitor, a transistor switch and a voltage source. The voltage source charges the capacitor before each clock signal pulse and the switch temporarily connects the
10 capacitor to the DUT's power input terminal at the start of each clock cycle so that the capacitor can deliver its charge to the DUT to provide the DUT's required transient charging current. The voltage to which the capacitor is charged is adjusted prior to the start of each clock signal cycle so that
15 the capacitor delivers the amount of charge the DUT is predicted to require during the next state change. The system can regulate the DUT's supply voltage even when there is significant path impedance between the capacitor and the DUT.

Thus the capacitor may be mounted on a probe card relatively
20 distant from DUT.

In accordance with a further aspect of the invention, in an alternative embodiment thereof, a DUT and a reference IC similar to the DUT are tested at the same time. However the reference IC is tested slightly in advance of the DUT so that
25 variations in the input power supply voltage of the reference IC due to changes in its current demand predict subsequent similar variations in the input current demand of the DUT. An amplifier amplifies variations in the voltage at the power input terminal of the reference IC to produce the time-varying
30 charging current needed by the DUT. The lag between the tests performed on the reference DUT and the second DUT is adjusted to match a signal path delay through the amplifier and interconnect path.

The concluding portion of this specification particularly
35 points out and distinctly claims the subject matter of the present invention. However those skilled in the art will best understand both the organization and method of operation of the invention, together with further advantages and objects thereof, by reading the remaining portions of the

specification in view of the accompanying drawing(s) wherein like reference characters refer to like elements.

BRIEF DESCRIPTION OF THE DRAWINGS

5 FIG. 1 is a block diagram illustrating a typical prior art test system including an integrated circuit tester connected through a probe card to a set of integrated circuit devices under test (DUTs),

FIGS. 2 and 3 are timing diagrams illustrating behavior
10 of signals within the prior art test system of FIG. 1,

FIG. 4 is a simplified plan view of the prior art probe card of FIG. 1,

FIG. 5 is a block diagram illustrating a test system implementing a system for reducing noise in the power supply
15 inputs of a set of DUTs in accordance with a first embodiment of the present invention;

FIG. 6 is a timing diagram illustrating behavior of signals within the test system of FIG. 5,

FIG. 7 is a block diagram illustrating operation of the
20 test system of FIG. 5 during a calibration procedure;

FIG. 8 is a simplified plan view of the probe card of FIG. 6;

FIGS. 9 and 10 are block diagrams illustrating test systems implementing second and third embodiments of the
25 present invention;

FIG. 11 is a timing diagram illustrating behavior of signals within the test system of FIG. 10;

FIGS. 12 is a block diagram illustrating a test system implementing a fourth embodiment of the present invention;

30 FIG. 13 is a timing diagram illustrating behavior of signals within the test system of FIG. 12;

FIG. 14 is a block diagram illustrating a fifth embodiment of the present invention;

35 FIG. 15 is a block diagram illustrating a sixth embodiment of the present invention;

FIG. 16 is a block diagram illustrating a seventh embodiment of the present invention; and

FIG. 17 is a timing diagram illustrating behavior of signals within the circuit of FIG. 16.

DESCRIPTION OF THE PREFERRED EMBODIMENTSSystem Architecture

FIG. 5 illustrates in block diagram form an integrated
5 circuit (IC) tester 30 linked through a probe card 32 to a set
of similar IC devices under test (DUTs) 34 in the form of die
on a semiconductor wafer. Probe card 32 includes a set of
probes 37 for accessing input/output terminal pads 39 on the
surfaces of DUTs 34 and also includes signal paths 46 linking
10 tester 30 to probes 37 to allow IC tester 30 to send a clock
signal (CLOCK) and other test signals to DUTs 14 and to convey
DUT output signals back to tester 30 so that the tester can
monitor the behavior of the DUTs.

Probe card 34 also links a main power supply to a power
15 input terminal 41 of each DUT 34 via probes 37. Power supply
36 produces a well-regulated output voltage V_A and
continuously supplies a current I_2 to DUT 34. For
illustrative purposes, FIG. 5 represents the inherent
impedances of the paths 43 through probe card 32 between main
20 power supply 36 and each DUT 34 as resistors R_1 . Due to a
voltage drop across resistor R_1 , the input supply voltage V_B
to each DUT 34 is always somewhat less than V_A .

In accordance with the invention, a first transistor
switch SW_1 mounted on probe card 32 links an auxiliary power
25 supply 38 to a set of capacitors C_2 mounted in probe card 32.

A set of second transistor switches SW_2 also mounted on probe
card 32 link each capacitor C_2 to the power input terminal of
a corresponding DUT 34. A resistor R_2 shown in FIG. 5
represents the inherent signal path impedance within probe
30 card 32 between each capacitor C_1 and the power input terminal
41 of a DUT 34 when switch SW_2 is closed. IC tester 30
provides an output control signal CNT_1 for SW_1 , a control
signal CNT_2 for controlling switches SW_2 and control data CNT_3
for controlling the magnitude of the output voltage V_C of
35 auxiliary power supply 38. As discussed in detail below,
auxiliary power supply 38, switches SW_1 and SW_2 and capacitors
 C_2 act as an auxiliary current source to inject current I_3
into the power input terminal 41 of each DUT under control of
IC tester 30.

Power Supply Noise

DUTs 34 implement synchronous logic in which switching transistors forming logic gates turn on and off in response to pulses of the periodic master CLOCK signal provided by tester 5 30. Each switching transistor has an inherent input capacitance, and in order to turn on or off the transistor, its driver must either charge or discharge the transistor's input capacitance. When drivers within DUTs 34 charge a transistor's input capacitance they increase the amount of 10 current I_1 that must be supplied to each DUT's power input terminal 41. Once the transistor's input capacitance is fully charged, its driver need only supply the relatively small amount of leakage current needed to keep the transistor's input capacitance charged so that the transistor 15 remains turned on or off. Thus immediately after each pulse of the CLOCK signal, there is a temporary increase in the power supply current I_1 input to each DUT 34 to provide the charging current necessary to change the switching states of various transistors. Later in a CLOCK signal cycle, after 20 those transistors have changed state, the demand for power supply current falls to a "quiescent" steady state level and remains there until the beginning of the next CLOCK signal cycle. The amount of additional current I_1 a DUT 34 needs at the start of each CLOCK signal cycle depends on the number and 25 nature of transistors that turn on or off during that particular CLOCK signal cycle.

If tester 30 always kept switches SW1 and SW2 open, main power supply 36 would always provide all of the current input I_1 to each DUT 34. In such case the temporary increase in 30 supply current I_1 due to the increased switching activity within each DUT 34 after each CLOCK signal pulse would cause a temporary increase in the voltage drop across the inherent impedance R_1 of the signal path 43 between main power supply 36 and DUT 34. This in turn would cause a temporary decline 35 in the voltage V_B at the DUT's power input terminal 41. FIG. 2 represents the behavior of V_B and I_1 when SW2 is always open. Since the dip in supply voltage V_B occurring after each CLOCK signal pulse edge is a form of noise that can adversely

affect the performance of DUTs 34, it is desirable to limit the magnitude of that voltage dip.

Predictive Charge Compensation

In accordance with the invention, IC tester 30 controls auxiliary power supply 38 and the states of switches SW1 and SW2 so that capacitor C2 supplies additional charging current I3 to DUT 34 at the start of each test cycle. The charging current I3, which only flows during an initial portion of each CLOCK signal cycle, combines with the current I2 output of the main power supply to provide the current input I1 to DUT 34. When charging current I3 provides approximately the same amount of charge the capacitance of switching transistors within DUT 34 acquire following a CLOCK signal pulse, there is relatively little change in the current I2 produced by main power supply 36 following the CLOCK signal pulse and therefore very little variation in supply voltage VB.

Thus prior to each CLOCK signal pulse, tester 30 supplies data CNT3 to auxiliary power supply 38 indicating a desired magnitude of VC and then closes switch SW1. Power supply 38 then charges all capacitors C2. The amount of charge capacitors C2 store is proportional to the magnitude of VC. When capacitors C2 have had time to fully charge, tester 30 opens switch SW1. Thereafter, at the start of the next CLOCK signal cycle, tester 30 closes all switches SW2 so that charge stored in capacitors C2 can flow as currents I3 into DUTs 34. Thereafter, when the need for transient charging current has passed, tester 30 opens switches SW2 so that only main power supply 36 supplies current to DUTs 34 during the remaining portion of the CLOCK signal cycle. This process repeats during every cycle of the CLOCK signal.

FIG. 6 illustrates the behavior of supply voltage VB, and currents I1, I2 and I3 during an initial portion of a CLOCK signal cycle. Current I1 exhibits a large temporarily increase above its quiescent level IQ1 after an edge of the CLOCK pulse at time T1 to charge capacitance within the DUT 34. Current I3 rises quickly to provide substantially all the additional charging current. The output current I2 of main power supply 38 exhibits only a relatively small perturbation from its quiescent value IQ2 resulting from small mismatches.

between I3 and the transient component of I2. Since the variation in I2 is small, the variation in VB is small. Thus the present invention substantially limits the power supply noise due to switching transients in DUTs 34.

5 Tester Programming

As mentioned above, the amount of additional charging current each DUT 34 draws at the start of a CLOCK signal cycle depends on the number of transistors that turn on or off during the CLOCK signal cycle and charging current varies from
10 cycle-to-cycle. In order to provide proper voltage regulation at DUT terminal 41, tester 30 has to predict how much charge DUT 34 is going to store following the each CLOCK signal pulse because it has to adjust the magnitude of auxiliary power supply output VC so that capacitors C2 store the proper amount
15 of charge prior to each CLOCK signal cycle.

FIG. 7 depicts a test system set up that allows tester 30 to experimentally determine the level to which it should set VC for each test cycle. A reference DUT 40 that is known to operate properly and which is similar to the ICs to be tested,
20 is connected to tester 30 via probe 32 in generally the same way DUTs 34 are to be connected so that tester 30 can perform the same test on reference IC 40. However probe card 32 also links the power supply terminal of reference IC 40 to an input terminal of tester 30 so that tester 30 can monitor the power
25 supply voltage VB. Tester 30 then executes only the first CLOCK cycle of the test while observing VB using the minimum value for VC. If VB falls below a desired lower limit during the CLOCK signal cycle, tester 38 repeats the first CLOCK signal cycle of the test using a higher value of VC. This
30 process is repeated iteratively until an appropriate value of VC for the first CLOCK signal cycle is established. The tester then iteratively executes the first two CLOCK signal cycles of the test while monitoring VB during the second CLOCK signal cycle and adjusting VC accordingly. The same procedure
35 is used to establish an appropriate value of VC for each successive CLOCK signal cycle of the test. Those values for VC may then be used when testing DUTs 34.

Designers typically use circuit simulators to simulate ICs before they are fabricated. When a circuit simulator

performs the same test on simulated ICs that an IC tester would perform on its real counterpart, the circuit simulator can be employed in an analogous manner to determine the sequence of VC values to be used during a test of the real IC.

5 Probe Card

FIG. 4 illustrates a typical prior art probe card 12 that connects voltage regulating capacitors C1 to the power input terminals of DUTs to limit power supply noise. Such probe cards must minimize the distance between voltage regulating
10 capacitors and the DUTs so as to minimize the impedance between the capacitors and the DUTs. Thus the capacitors preferably are mounted on the probe card in or near a small area 27 above the probes that access the DUTs. Since there is little space on the probe card near the probes, the size and
15 number of regulating capacitors C1 that can be deployed on probe card 12 is limited. This limitation on capacitor mounting space can limit the number of DUTs that can be concurrently tested.

FIG. 8 is a simplified plan view of the probe card 32 of
20 FIG. 5 in accordance with the invention. Contact points 45 accessed by IC tester 30 of FIG. 7 are distributed over a relatively large area of the upper surface 43 of probe card 32 while the probes 37 (not shown) that contact DUTs 34 are concentrated under a relatively small central area 47 of the
25 probe card. Since the voltage VC to which capacitors C2 are charged can be adjusted to accommodate significant path impedance R2 (FIG. 5) between any switch SW2 and terminal 41 of DUT 34, capacitors C2 can be mounted on probe card 32 at a significantly greater distance from central area 47 above the
30 DUT probes than capacitors C1 of FIG. 4. Also since capacitors C2 are charged to a higher voltage than capacitors C1, they can be smaller than capacitors C1. Since capacitors C2 of probe card 32 of FIG. 8 can be smaller and further from the center of the probe card than capacitors C1 of the prior
35 art probe card 12 of FIG. 4, a larger number of capacitors C2 can be mounted on probe card 32. Thus a test system employing probe card 32 in accordance with the invention can concurrently test more DUTs than a test system employing a prior art probe card 12 of FIG. 4.

Probe Card With On-Board Pattern Generator

FIG. 9 illustrates an alternative embodiment of the invention including a probe card 50 generally similar to probe card 32 of FIG. 7 except that it has mounted thereon a "power control IC" 52. Power control IC 52 includes a pattern generator 54 that carries out the pattern generation function of IC tester 30 of FIG. 7 with respect to producing the control signals and data CNT1, CNT2 and CNT3 for controlling switches SW1 and SW2 and auxiliary power supply 38. Power control IC 52 includes a conventional pattern generator 54 programmed before the start of a test by externally generated programming data provided via a conventional computer bus 56.

Pattern generator 54 begins generating its output data pattern in response to a START signal from an IC tester 58 marking the start of a test and produces its output CNT1, CNT2, CNT3 data pattern in response to the same system clock (SYSCLK) that clocks operations of tester 58.

When the required capacitance C2 is sufficiently small, switches SW1 and SW2 and capacitors C2 may be implemented within power control IC 52 as shown in FIG. 9. IC 52 should be mounted on the probe card as near as possible to the DUT probes. Merging switches SW1 and SW2 and capacitors C2 and the pattern generation function of tester 30 into a single IC 52 reduces the cost and complexity of probe card 32 and reduces the required number of tester 30 output channels. However when necessary capacitors C2 can be implemented by discrete components external to power control IC 52.

Pulse Width Modulated Charge Flow

FIG. 10 illustrates an embodiment of the invention that is generally similar to the embodiment of FIG. 5. However in FIG. 10 switch SW1 is omitted from probe card 60 so that the VC output of auxiliary power supply 38 is directly connected to capacitors C2. Also the output voltage VC is fixed and not adjusted by IC tester 30 so that C2 charges to the same value prior to each CLOCK signal pulse. In this configuration IC tester 30 controls the amount of charge capacitors C2 deliver to DUTs 34 at the start of each CLOCK pulse by pulse width modulating switches SW2 via control signal CNT2. The amount of time tester 30 closes switches SW2 following the leading

edge of a CLOCK signal pulse determines the amount of charge capacitors C2 deliver to DUTs 34. Alternatively, the shape of the I3 current flow illustrated in FIG. 6 can be more closely approximated when tester 30 rapidly increases and then
5 decreases the duty cycle of the CNT2 signal as illustrated in FIG. 11.

Analog Modulated Charge Flow

FIG. 12 illustrates an embodiment of the invention that is generally similar to the embodiment of FIG. 10. However in
10 FIG. 12 the transistor switches SW2 are replaced with transistors Q2 operated in their active regions when DUTs 34 are undergoing state changes and require additional current I3. In this configuration, the CNT2 output of IC tester 30 is a data sequence applied as input to an analog-to-digital (A/D)
15 converter 63 mounted on probe card 61. The data sequence CNT2 represents a predicted demand for charging current I3 during each CLOCK signal cycle. A/D converter 63 responds to the CNT2 data sequence by producing an analog signal CNT4 input to the bases of transistors Q2 that varies during each CLOCK
20 signal cycle as illustrated in FIG. 13. Analog signal CNT4 controls the amount of current I3 each transistor Q2 allows to flow out of a capacitor C2 so that it substantially matches the predicted transient component of the current I1 demanded by DUT 34. A/D converter 63 may be implemented within IC
25 tester 30 instead of being mounted on probe card 61.

Charge Prediction Using Reference DUT

FIG. 14 illustrate an embodiment of the invention wherein a reference DUT 60 similar to DUTs 34 is tested in a similar way except that tester 30 tests the reference DUT 60 slightly
30 in advance of the other DUTs by advancing the CLOCK and other input signals it supplies to reference DUT 60. A main power supply 62 powers all DUTs 34 while an auxiliary power supply 64 powers reference DUT 60. A capacitor C4 mounted on probe card 66 near reference DUT 60 regulates the voltage VREF at
35 its power input terminal 68 in a conventional manner so that it stays within its allowed operating range. A capacitor C5 links VREF to a set of amplifier's A1, and a capacitor C6

links the output of each amplifier A1 to the power input terminal 70 of each DUT 34.

Though well-regulated, the supply voltage VREF at the input terminal 68 of reference DUT 60 falls below its
5 quiescent level by a small amount following the start of each CLOCK signal cycle due to the reference DUT's transient charging current demand. The amount of voltage decline in VREF is proportional to the amount of transient charging current drawn by reference DUT 60. Since reference DUT 60 is
10 similar to DUTs 34 and is tested slightly in advance of DUTs 34, a decline in VREF predicts the amount of transient charging current each DUT 34 a short time later.

Amplifiers A1, acting through capacitors C5 and C6, amplify the AC component of VREF to produce output currents I3
15 that augment the current outputs I2 of main power supply 62 to provide the current input I1 to each DUT 34. The amount of time by which tester 30 advances the test of reference DUT 60 is set to equal the delay between variations in reference voltage VREF and corresponding variations in currents I3.
20 With the (negative) gain of each amplifier A1 appropriately adjusted by an externally generated signal (GAIN), currents I3 will substantially match the transient charging currents required by DUTs 34.

Charge Prediction In Non Testing Environments

25 In addition to being useful for reducing power supply noise when testing integrated circuits, embodiments of the present invention can also be employed to reduce power supply noise in application in which an integrated circuit passes through a succession of states that can be predicted.

30 FIG. 15 illustrates an example embodiment of the invention in which an integrated circuit 80 passes through a predictable succession of states in response to edges of an externally generated CLOCK signal supplied as input thereto. IC 80 receives power from a main power supply 82. An
35 auxiliary power supply 84 charges a capacitor C2 via a switch SW1 when switch SW1 is closed. Capacitor C2 supplies its charge as additional current input to IC 80 when a switch SW2 is closed. A "charge predictor" circuit 86 responds to the CLOCK signal by asserting a signal CNT1 to close switch SW1

and deasserting a control signal CNT2 to open switch SW2 during a portion of each CLOCK signal cycle in which IC 80 is not changing state. This allows auxiliary power supply 84 to charge capacitor C2 between state changes. Charge predictor circuit 86 asserts control signal CNT2 to close switch SW2 and deasserts control signal CNT1 to open switch SW1 during a portion of each CLOCK signal cycle in which IC 80 is changing state, thereby allowing capacitor C2 to deliver current to the power input of IC 80 to provide its transient current needs. Charge predictor 86 also provides control data CNT2 to auxiliary power supply 84 to adjust its output voltage VC so that it charges capacitor C2 to a level determined in accordance with an amount of current IC 80 is expected to draw during a next state change. Charge predictor 86 is suitably implemented by a conventional pattern generator or any other device capable of producing output data sequences CNT1, CNT2 and CNT3 that are appropriate for transient current requirements of IC 80 for its expected sequence of states. Switches SW1 and SW2 and/or capacitor C2 may be implemented either external to IC 80 as illustrated in FIG. 15 or may be implemented internal to IC 80.

Charge Averaging

FIG. 16 illustrates a simple version of the invention suitable for use in applications wherein the amount of charging current an IC 80 is expected to draw at the start of each CLOCK signal cycle lies within a relatively limited, predictable range. As shown in FIG. 16, an inverter 90 inverts the CLOCK signal to provide the CNT1 control signal input to a switch SW1 coupling a main power supply to a capacitor C2. The CLOCK signal directly provides a CNT2 control signal input to a switch SW2 connecting capacitor C2 to a power input of IC 80 normally driven by a main power supply 82. As illustrated in FIG. 17, the CLOCK signal drives the CNT2 signal high to close switch SW2 during a first half of each CLOCK signal cycle and drives CNT1 high to close switch SW1 during a second half of each CLOCK signal cycle.

The output voltage VC of auxiliary power supply 84 is set to a constant value so that it charges capacitor C2 to the same level prior to the start of each CLOCK signal cycle. The

level of VC is set to appropriately position the range over which power supply input voltage VB swings when IC 80 is drawing additional charging current at the start of each CLOCK signal cycle. For example when we want the quiescent value of VB to lie at the middle of its range, we can adjust VC so that capacitor C2 supplies an amount of charging current that is in the middle of the range of charging currents IC 80 is expected to draw. On the other hand, if we want to prevent VB from falling much below its quiescent value but are willing to allow VB to rise above its quiescent value, we can adjust VC so that capacitor C2 supplies the maximum amount of charging current IC 80 is expected to draw. While capacitor C2 may supply too little charging current during some CLOCK signal cycles and too much charging current during other CLOCK signal cycles, in many applications the system illustrated in FIG. 16 nonetheless can keep the swings in VB within acceptable limits when VC is suitably adjusted. Note that the systems of FIGS. 5, 9, 14 and 15 can be programmed to operate in a similar manner by setting control data CNT3 to the same value for every CLOCK signal cycle.

Thus has been shown and described a system for limiting power supply noise of an integrated circuit device when it is being tested. While the forgoing specification has described preferred embodiment(s) of the present invention, one skilled in the art may make many modifications to the preferred embodiment without departing from the invention in its broader aspects. While the invention is illustrated herein as reducing noise in a system employing only a single main power supply, it will be appreciated that the invention can be employed in environments in which more than one main power supply provide power to DUTs. Also while the apparatus is illustrated as operating in connection with DUTs having a single power input, it will be appreciated that the apparatus can be adapted to operate in connection with DUTs having multiple power inputs. For example referring to FIG. 7, if each DUT 34 had more than one power supply input terminal 41, an additional auxiliary power supply 38, an additional capacitor C2 and additional switches SW1 and SW2 would be provided for each additional DUT power input terminal. Also,

it should be noted that while the apparatus is described as providing additional charging current following a leading edge of a CLOCK signal pulse, it may be easily adapted to provide additional charging current following a trailing edge of the
5 CLOCK signal pulse for use with DUTs that switch on trailing CLOCK signal edges. The appended claims therefore are intended to cover all such modifications as fall within the true scope and spirit of the invention.

CLAIMS

What is claimed is:

1. An apparatus for limiting variation in power supply voltage (VB) at a power input terminal (41) of an integrated circuit (IC) (34) receiving power from a main power supply (36), wherein the variation in voltage results from a transient current the IC draws at its power input terminal when a circuit implemented by the IC undergoes a state change, wherein an amount of transient current said IC draws during a state change of said sequence depends on a nature of the state change, and wherein said circuit undergoes a sequence of state changes, the apparatus comprising:

a source of current (C2, SW1, 30, 38); and control means (30, SW2, Q2) for connecting said source of current to said power input terminal during said state changes and for disconnecting said source of current from said power input terminal between said state changes.

2. The apparatus in accordance with claim 1 wherein said source of current comprises:
a capacitor (C2), and
charging means (30, 38, SW1) for charging said capacitor between said state changes.

3. The apparatus in accordance with claim 2 wherein prior to one of said state changes said charging means charges said capacitor to a voltage of magnitude determined in accordance with an amount of transient current said IC draws during said one of said state changes.

4. The apparatus in accordance with claim 2 wherein said charging means comprises:
an auxiliary power supply (38) for generating an output voltage;
first switch means (SW1) for connecting said auxiliary power supply to said capacitor and for disconnecting said

auxiliary power supply from said capacitor as signaled by a first control signal (CNT1) supplied as input thereto, and control means (30) for generating said first control
10 signal, said control means signaling said first switch means to connect said auxiliary power supply to said capacitor between said state changes and to disconnect said power supply from said capacitor during said state changes.

5. The apparatus in accordance with claim 4 wherein said auxiliary power supply adjusts a magnitude of its output voltage in accordance with control data (CNT3)
5 supplied as input thereto, and wherein between said state changes said control means adjusts said control data to set the auxiliary power supply output voltage to a level determined in accordance with an amount of transient current said IC draws during a next one of
10 said state changes.

6. The apparatus in accordance with claim 2 wherein said control means comprises:
second switch means (SW2) for selectively connecting said capacitor to said power input terminal and disconnecting said
5 capacitor from said power input terminal as signaled by a second control signal (CNT2) supplied as input thereto, and means (30) for signaling said second switch means via said second control signal to connect said capacitor to said power input terminal during said state changes and to
10 disconnect said capacitor from said power input terminal between said state changes.

7. The apparatus in accordance with claim 2 wherein said control means comprises:
a transistor (Q2) connected between said capacitor and said power input terminal and providing a signal path
5 therebetween having an impedance controlled by a second control signal (CNT2) supplied as input thereto, and means (30) for signaling said transistor via said second control signal to set said impedance to a low value during a first of said state changes and to set said impedance to a

high value between said first of said state changes and a second of said state changes.

8. The apparatus in accordance with claim 7 wherein said second control signal sets said low value of said impedance during said first of said state changes in accordance with an amount of transient current said IC draws during said first of said state changes.

9. An apparatus for limiting variation in power supply voltage (VB) at a power input terminal (41) of an integrated circuit (IC) (34) receiving power from a main power supply (36), wherein the variation in voltage results from a transient current the IC draws at its power input terminal when a circuit implemented by the IC undergoes a state change, wherein an amount of transient current said IC draws during the state change depends on a nature of the state change, and wherein said circuit undergoes a sequence of state changes, the apparatus comprising:

a capacitor (C2);

an auxiliary power supply (38) for generating an output voltage;

first switch means (SW1) for connecting said auxiliary power supply to said capacitor and for disconnecting said auxiliary power supply from said capacitor as signaled by a first control signal (CNT1) supplied as input thereto, and

second switch means (SW2) for selectively connecting said capacitor to said power input terminal and disconnecting said capacitor from said power input terminal when signaled by a second control signal (CNT2) supplied as input thereto; and

control means (30) for signaling said first switch means via said first control signal to connect said auxiliary power supply to said capacitor between said state changes and to disconnect said power supply from said capacitor during said state changes, and for signaling said second switch means to connect said capacitor to said power input terminal during said state changes and to disconnect said capacitor from said power input terminal between said state changes.

30

10. The apparatus in accordance with claim 9
wherein said auxiliary power supply adjusts a magnitude
of its output voltage in accordance with control data (CNT3)
supplied as input thereto, and

5 wherein said control means adjusts said control data
prior to said state changes to set said auxiliary power supply
output voltage to a level determined in accordance with an
amount of transient current said IC draws during said state
changes.

10

11. An apparatus for testing an integrated circuit
device under test (DUT) by transmitting a sequence of test
signals to the DUT causing a circuit implemented by the DUT to
undergo a sequence of state changes, said DUT having a power
5 input terminal (41) receiving a first current (I1), wherein
said DUT increases its demand for said first current during
said state changes and decreases its demand for said first
current between said state changes, the apparatus comprising:

10 an integrated circuit (IC) tester (30) for generating
said sequence of input signals and for generating control data
(CNT1, CNT2, CNT3);

a main power supply (36) for generating a second current
(I2);

15 means for conveying said test signals from said tester to
said DUT and for conveying said second current from said main
power supply to power input terminal of said DUT;

an auxiliary power supply (38) for generating a charging
voltage (VC);

a capacitor (C2); and

20 means (38, SW1, SW2) for responding to said control data
by connecting said capacitor to said auxiliary power supply
such that said auxiliary power supply charges said capacitor
between said state changes, and for alternatively connecting
said capacitor to said power input terminal during said state
25 changes such that said capacitor delivers a third current (I3)
to said DUT during said state changes.

12. The apparatus in accordance with claim 11 wherein
said control data generated by said IC tester also controls a

magnitude of said charging voltage generated by said auxiliary power supply.

13. The apparatus in accordance with claim 12 wherein said IC tester adjusts said control data prior to said state changes to set said charging voltage to a level that is a function of an expected amount of increase of the demand of
5 said DUT for said first current during said state changes.

14. An apparatus for testing an integrated circuit device under test (DUT) by transmitting a sequence of test signals to the DUT causing a logic circuit implemented by the DUT to undergo a sequence of state changes during a test, said
5 DUT having a power input terminal (41) receiving a first current (I1), wherein said DUT increases its demand for said first current during said state changes and decreases its demand for said first current between said state changes, the apparatus comprising:

10 an integrated circuit (IC) tester for generating said sequence of test signals and a START signal indicating a start of said test;

a main power supply (36) for generating a second current (I2);

15 an auxiliary power supply (38) for generating a charging voltage (VC); and

a probe card (50) comprising:

20 means for conveying said test signals from said tester to said DUT and for conveying said second current from said main power supply to said power input terminal of said DUT;

a capacitor (C2);

25 pattern generation means (54) for receiving said START signal and for generating a control data sequence (CNT1, CNT2, CNT3) in response to said START signal; and

30 means (38, SW1, SW2) for responding to said control data sequence by connecting said capacitor to said auxiliary power supply such that said auxiliary power supply charges said capacitor between said state changes, and for alternatively connecting said capacitor to said power input

terminal during said state changes such that said capacitor delivers a third current (I3) to said DUT during said state changes.

15. The apparatus in accordance with claim 13 wherein said control data sequence produced by said pattern generation means also controls a magnitude of said charging voltage generated by said auxiliary power supply.

16. The apparatus in accordance with claim 12 wherein said control data sequence adjusts said charging voltage before said state changes to a level that is a function of an expected amount of increase of said demand of said DUT for said first current during said one of said state changes.

17. An apparatus for testing an integrated circuit device under test (DUT) by transmitting a first sequence of test signals to the DUT causing a first logic circuit implemented by the DUT to undergo a sequence of state changes during a test, said DUT having a first power input terminal (70) for receiving a first current, wherein said DUT increases its demand for said first current during state changes and decreases its demand for said first current (I1) between state changes, the apparatus comprising:

10 an integrated circuit (IC) tester (30) for generating said first sequence of test signals and for generating a similar second sequence of test signals that precedes said first sequence of test signals;

15 a reference IC similar to said DUT and having a second power input terminal (68) similar to said first power input terminal of said DUT;

a main power supply (36) connected to said first power input terminal of said DUT for supplying a second current (I2) as input thereto;

20 an auxiliary power supply (38) connected to said second power input terminal of said reference IC;

first means (66) for conveying said first sequence of test signals from said tester to said DUT and for conveying said second test signal to said reference IC, wherein said DUT

25 begins a state change of said sequence of state changes with a
first delay after said reference IC begins a similar state
change; and

second means (C5, C6, A1) for monitoring a supply voltage
appearing at said second power input terminal of said
30 reference IC and for supplying with a second delay a third
current (I3) into said first power input terminal of said DUT
of magnitude determined in accordance with said variation of
said supply voltage.

18. The apparatus in accordance with claim 17 wherein
said second means comprises:

an amplifier (A1) having an input and an output, for
producing said third current at its output in response to a
5 signal applied to its input;

a first capacitor (C5) linking the input of said
amplifier to said second power terminal of said reference IC;
and

10 a second capacitor (C6) linking the output said amplifier
to said first power terminal of said DUT.

19. The apparatus in accordance with claim 17 wherein
said first delay is substantially equal to said second delay.

20. The apparatus in accordance with claim 17 wherein an
amount of said current said second means supplies to said
first power input terminal of said DUT is substantially
proportional to an amount of variation in said supply voltage
5 appearing at said second power input terminal.

21. An apparatus for linking an integrated circuit (IC)
tester, a main power supply and an auxiliary power supply to
an to an IC device under test (DUT) having a power input
terminal, the apparatus comprising:

5 a probe card (50) for providing test signal paths between
the IC tester and the DUT and providing a power signal path
between the main power supply and the power input terminal of
the DUT; and

power control means (52) mounted on said probe card and
10 connected to said auxiliary power supply and said power input
terminal of said DUT, said power control means receiving and
storing charge from said auxiliary power supply when a demand
of said DUT has a low demand for current at its power input
terminal and delivering its stored charge to said DUT when the
15 demand of said DUT has a high demand for current at its power
input terminal.

22. The apparatus in accordance with claim 21 wherein
said power control means comprises:

a capacitor (52) for storing said charge; and
control means (54, SW1, SW2) for linking said capacitor
5 to said auxiliary supply when said DUT has said low demand for
current and for linking said capacitor to said power input
terminal when DUT has said high demand for current.

23. The apparatus in accordance with claim 22 wherein
said control means comprises:

switch means (SW1, SW2) for selectively linking said
capacitor alternatively to said auxiliary power supply and
5 said power input terminal in response to a control data
sequence applied as input thereto; and
means (54) for storing and reading out said control data
sequence to said switch means.

24. A method for supplying a first current to a power
input terminal of an integrated circuit (IC) wherein a demand
of said IC for said first current varies between a low level
and a high level, the method comprising the steps of:

- 5 a. continuously connecting a main power supply to said
power input terminal such that said main power continuously
supplies a second current (I2) to said power input terminal;
and
b. connecting a capacitor to an auxiliary power supply
10 when said demand of said IC is near said low level such that
said capacitor stores charge from said auxiliary power supply,
and otherwise connecting said capacitor to said power input
terminal when said demand of said IC for first current rises

substantially above said low level, such that said capacitor
15 transfers its stored charge as a third current (I3) input to
said power input terminal, wherein said first current is a sum
of said second and third currents.

25. The method in accordance with claim 24 wherein step
b comprises the substeps of:

generating and storing a data sequence,
linking said capacitor to said auxiliary power supply and
5 said power input terminal through switch means, and
reading out said data sequence as input to said switch
means, wherein said data sequence causes said switch means to
connect said capacitor to said auxiliary power supply when
said demand of said IC is near said low level and to otherwise
10 connect said capacitor to said power input terminal when said
demand of said IC for first current rises substantially above
said low level.

26. The method in accordance with claim 24 wherein step
b comprises the substeps of:

generating and storing a data sequence ,
connecting said capacitor to said auxiliary power supply,
5 connecting said capacitor to said power input terminal
through a transistor,
reading out said data sequence as input to an analog-to-
digital (A/D) converter such that A/D converter produces an
output analog signal, and
10 supplying said analog signal as a control input to said
transistor, wherein said analog signal causes said transistor
to provide a path between said capacitor and said power input
terminal having an impedance that varies with said demand of
said IC for said first current.

15

1/8

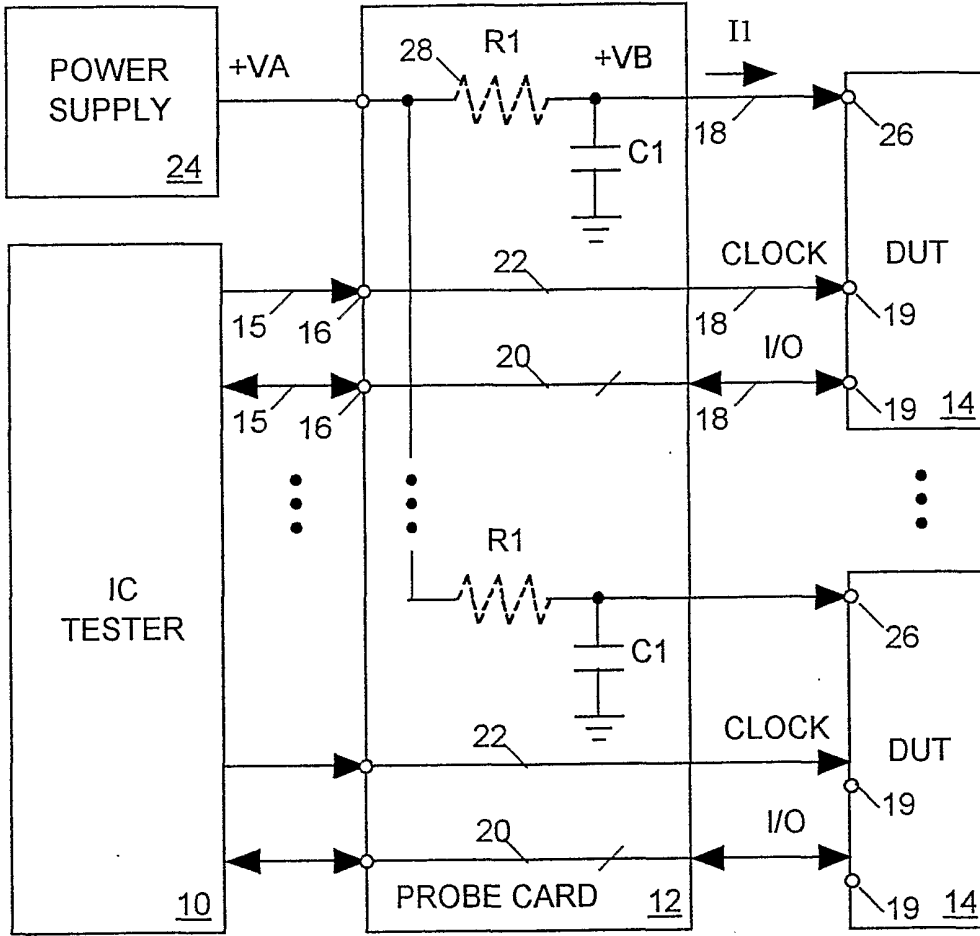

FIG. 1
(PRIOR ART)

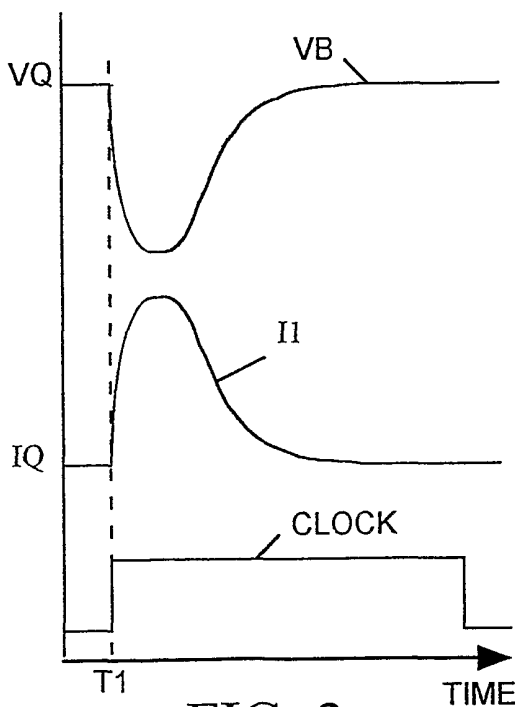

FIG. 2

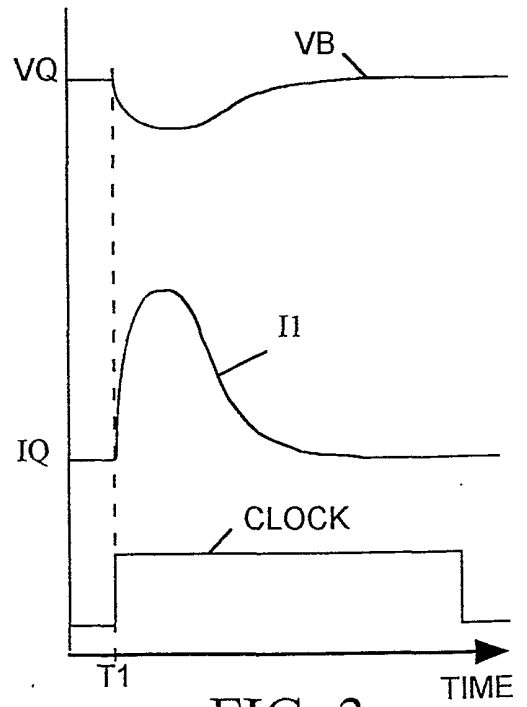

FIG. 3

2/8

FIG. 4
(PRIOR ART)

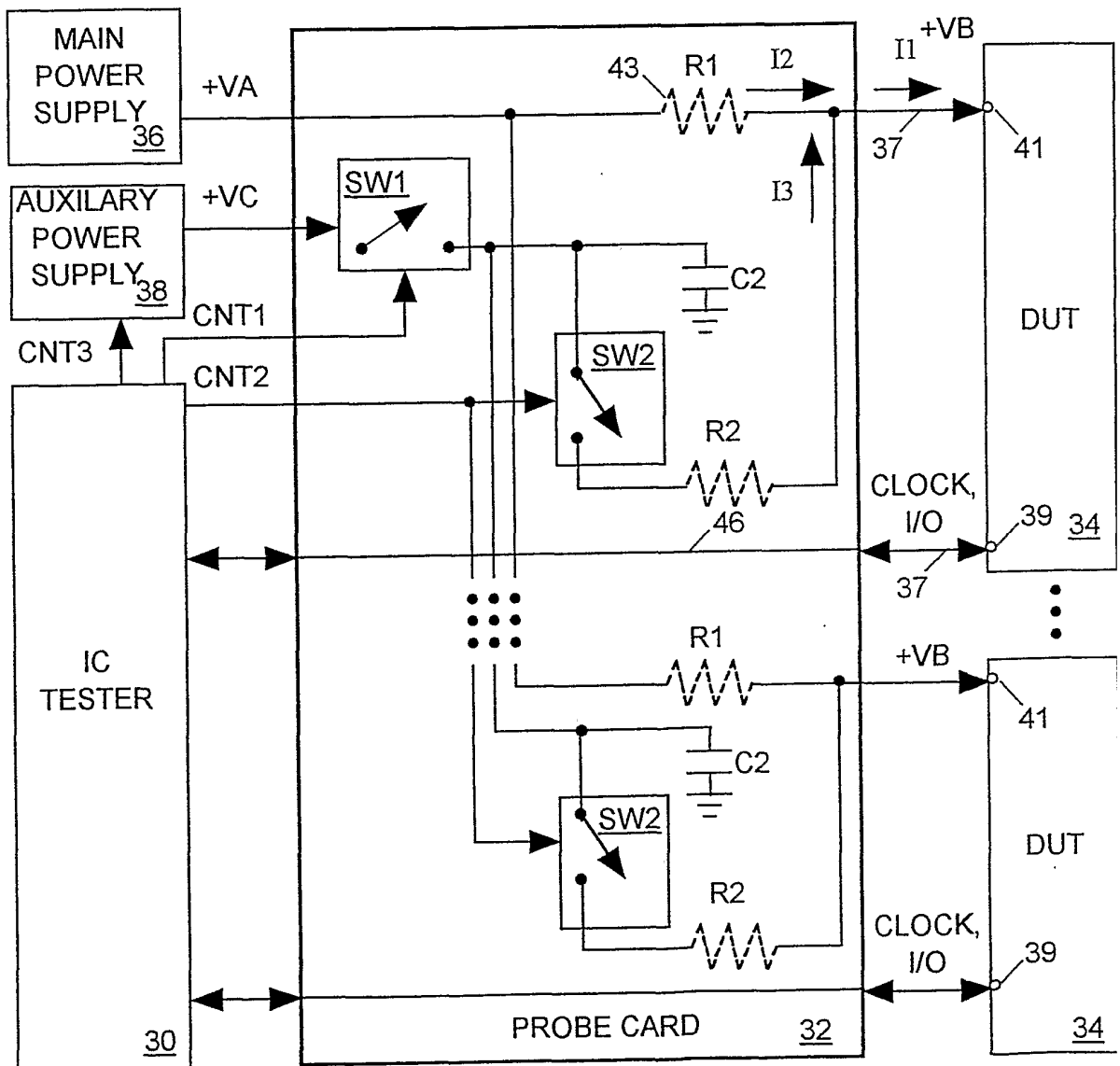
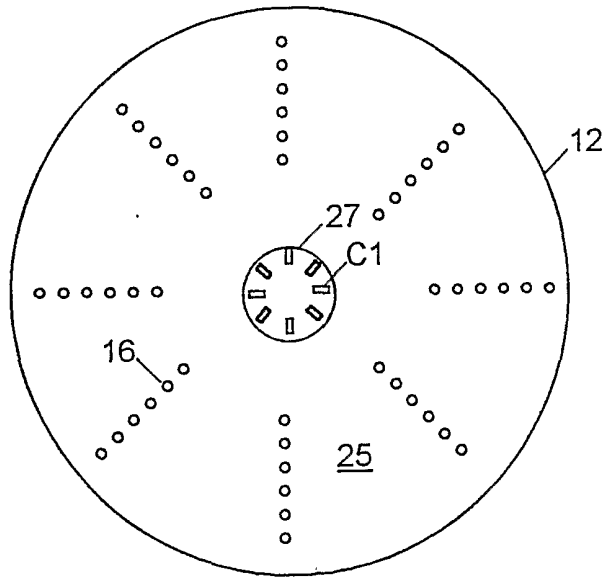

FIG. 5

FIG. 6

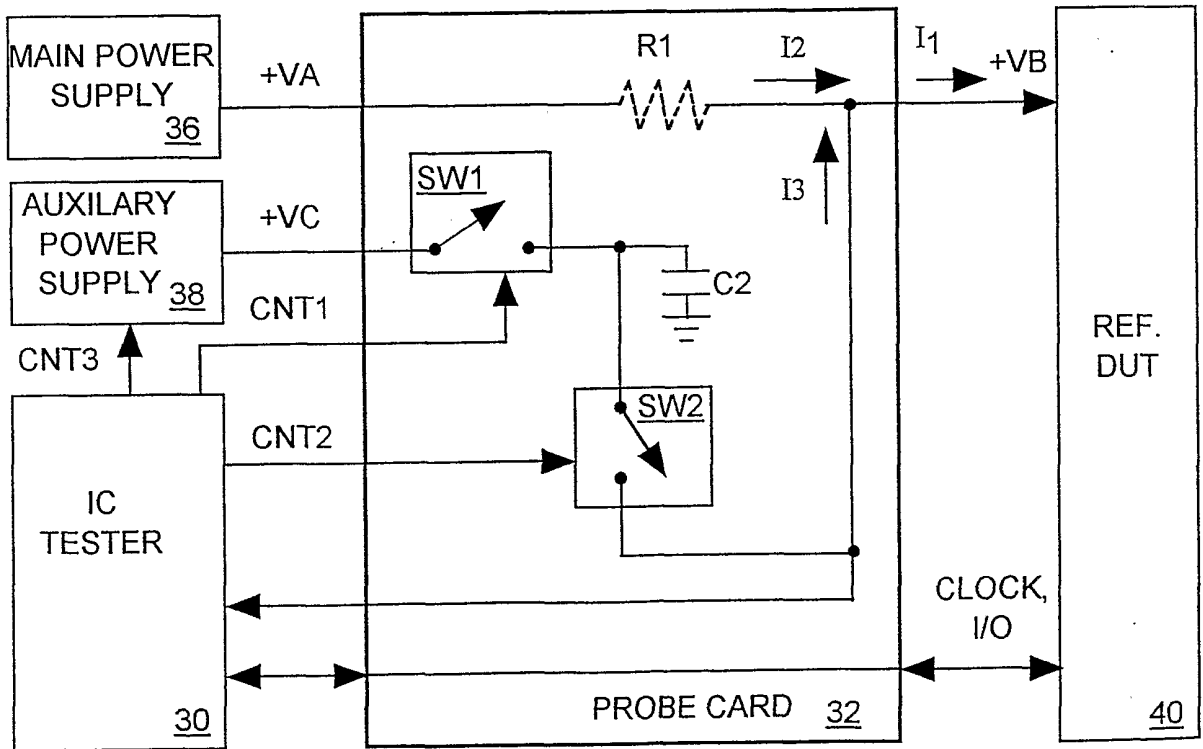
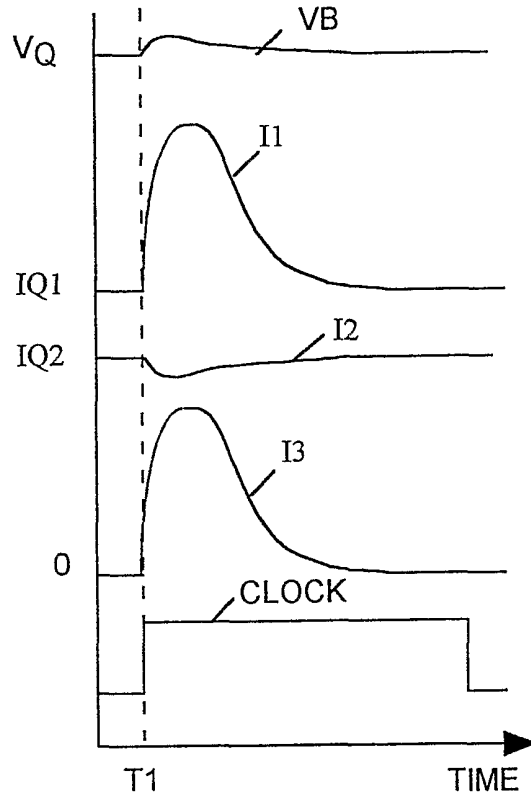

FIG. 7

FIG. 8

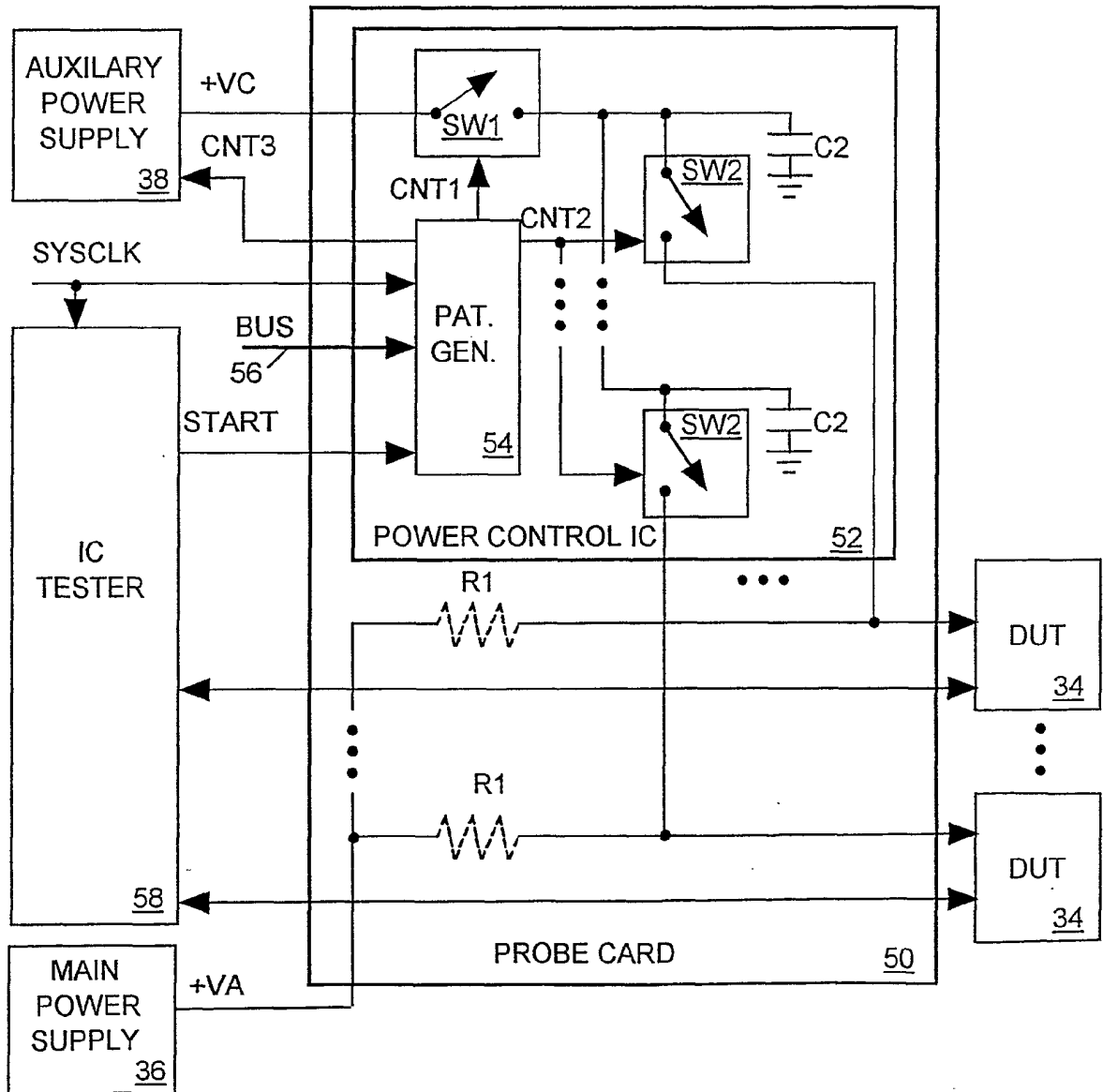
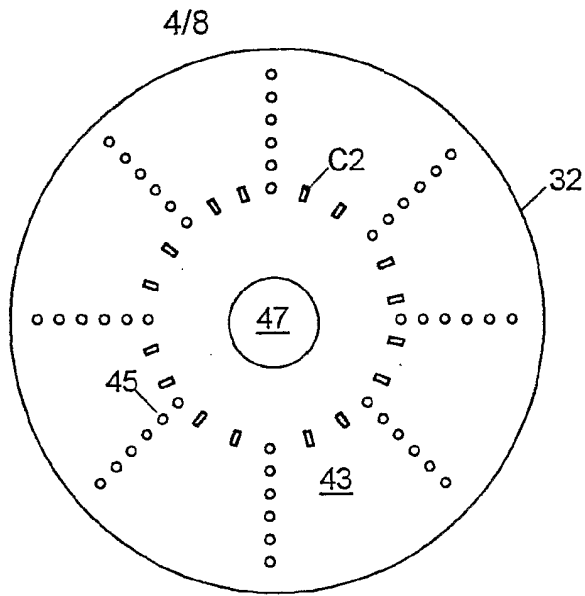

FIG. 9

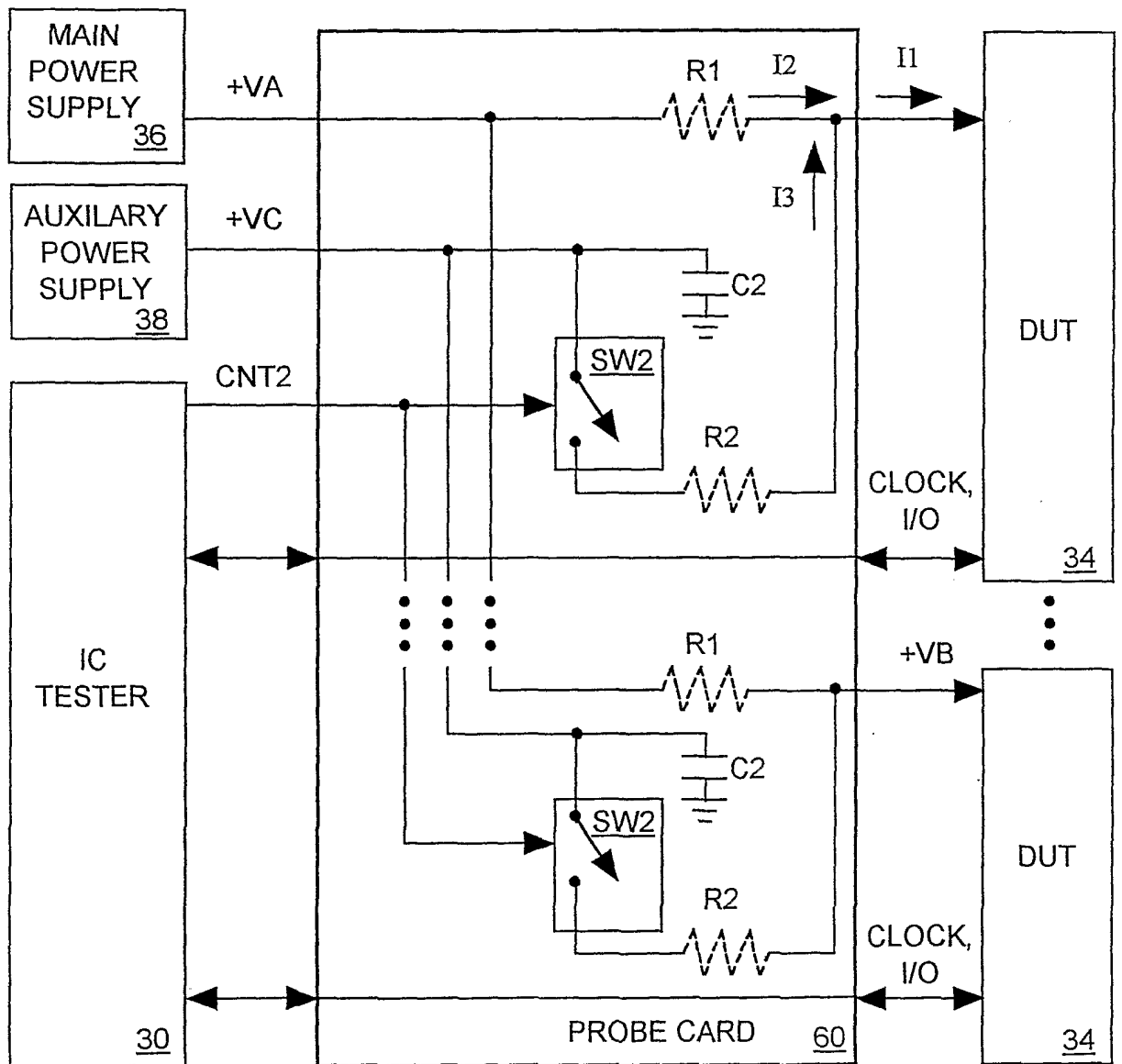

FIG. 10

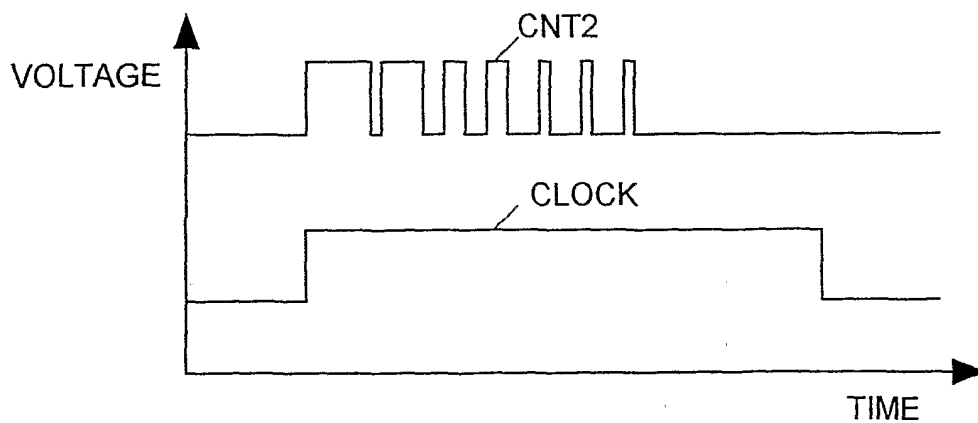

FIG. 11

6/8

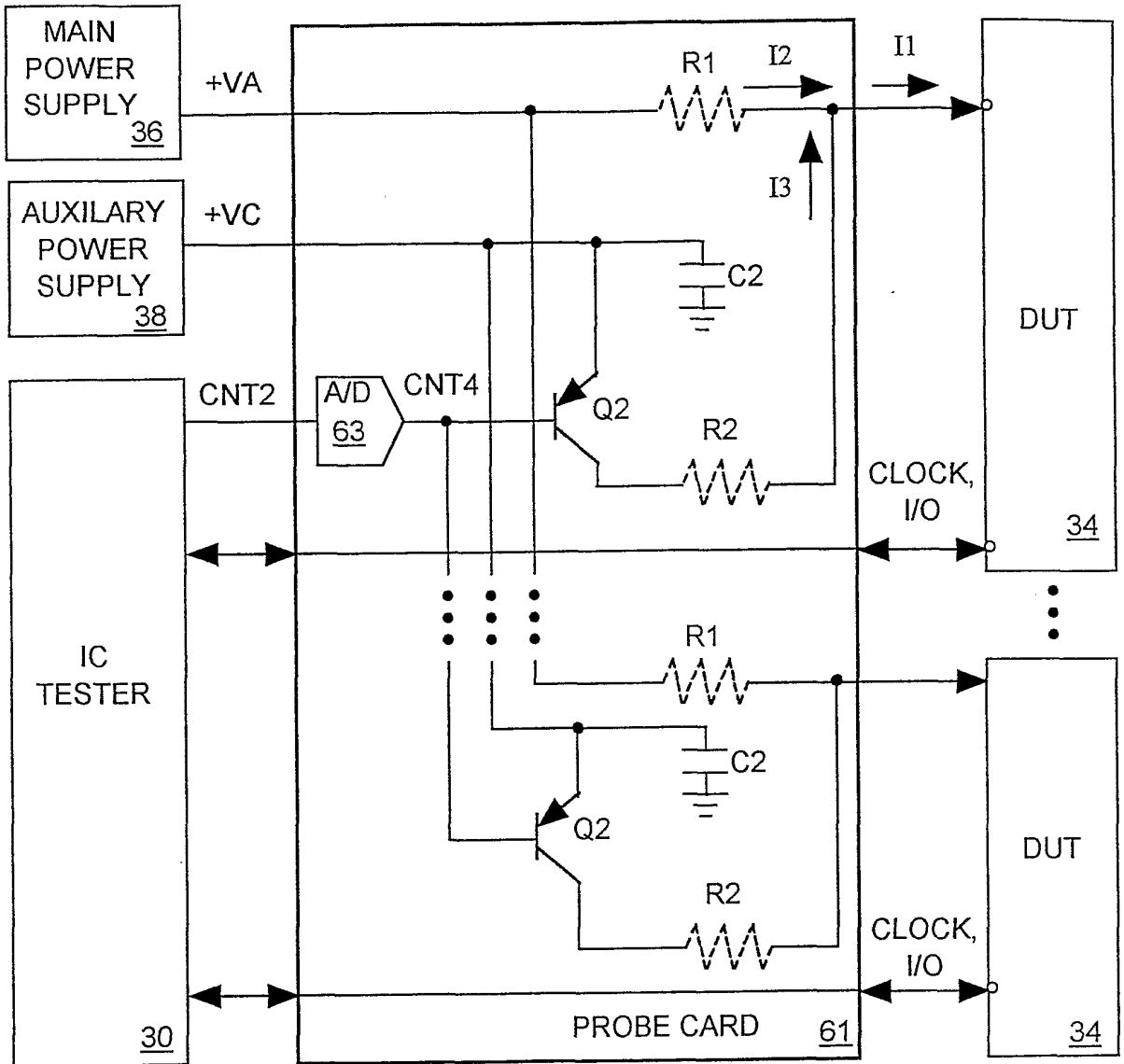
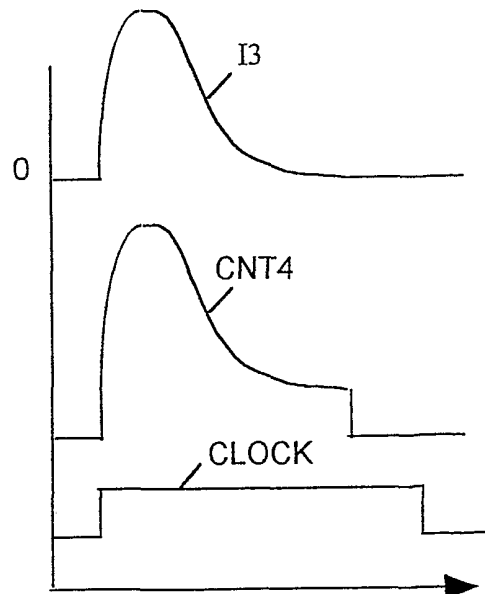

FIG. 12

FIG. 13



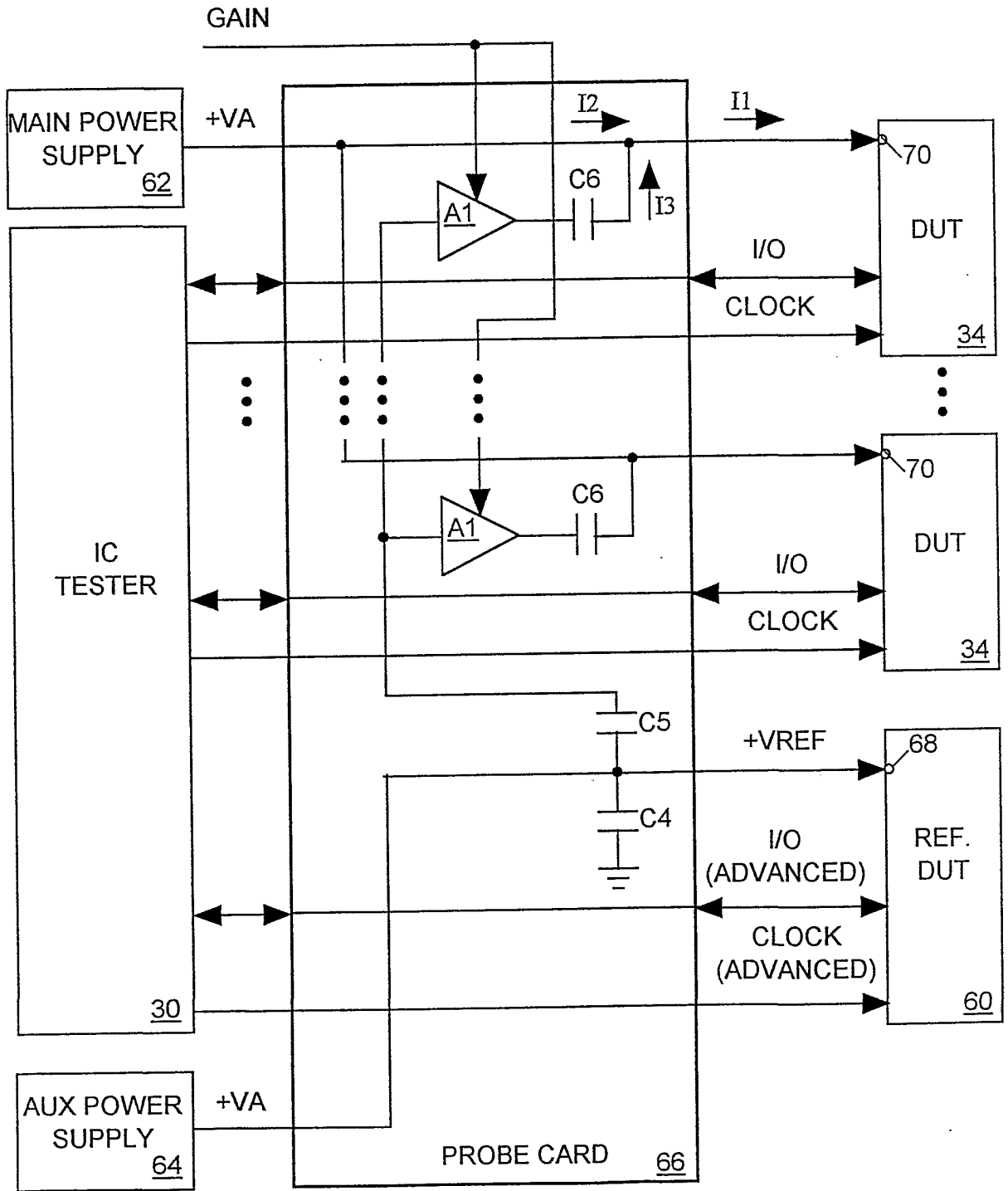

FIG. 14

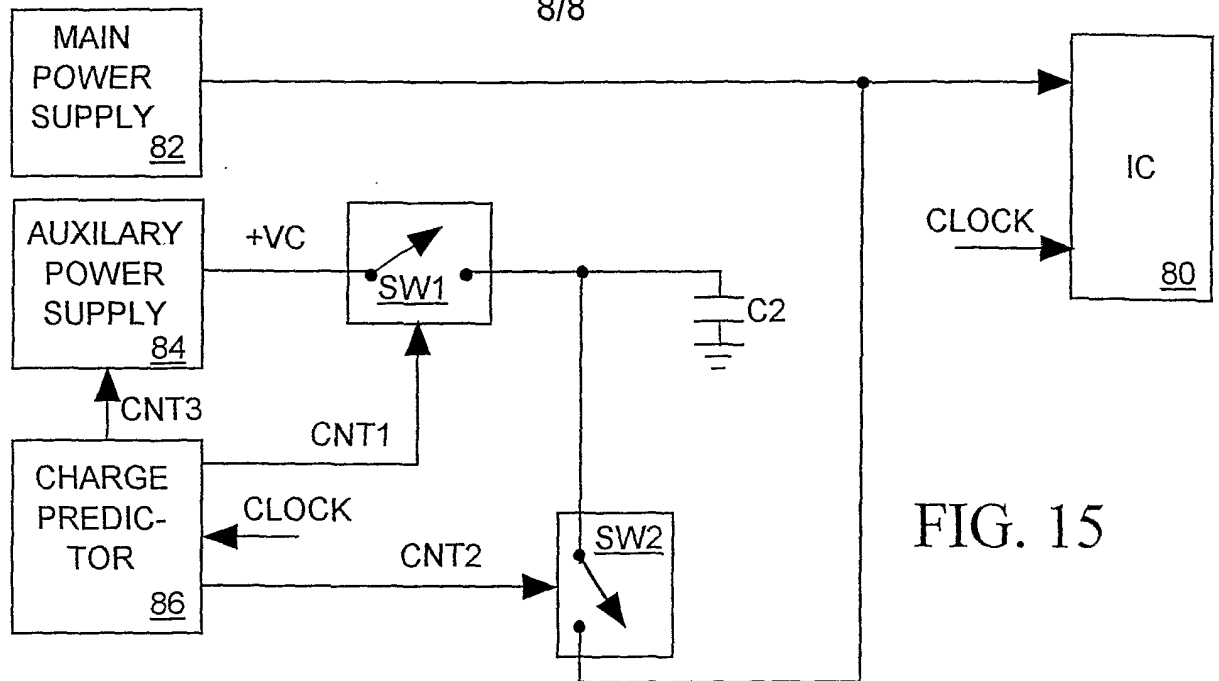

FIG. 15

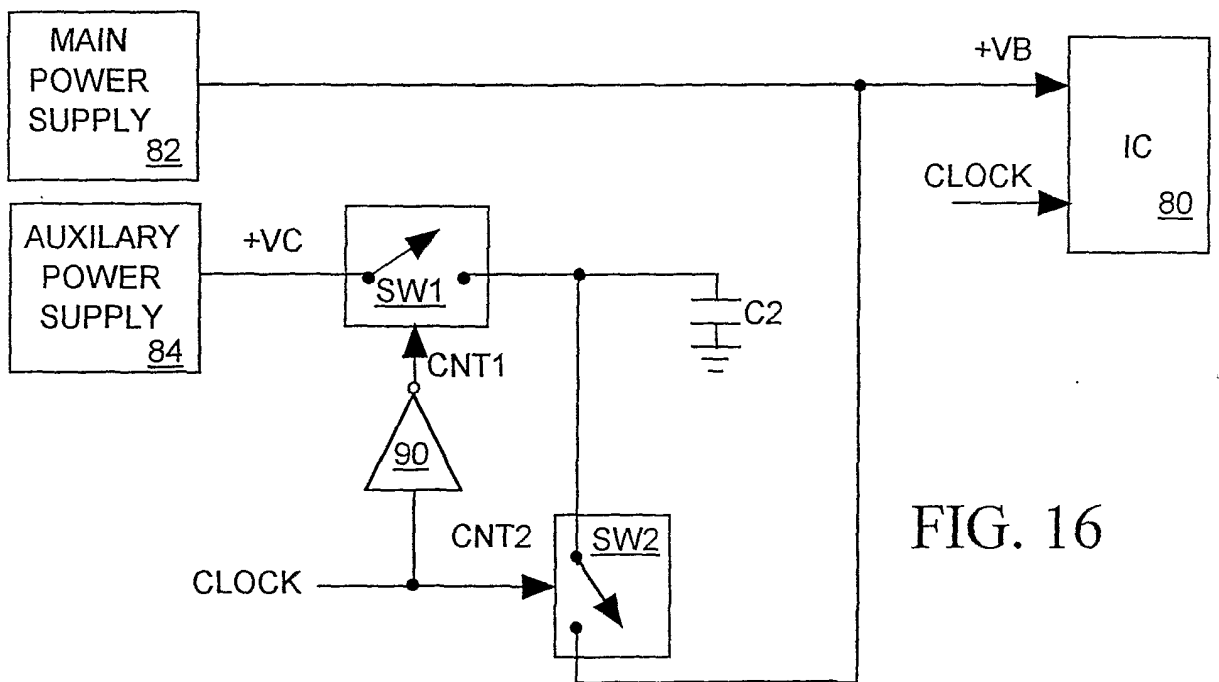

FIG. 16

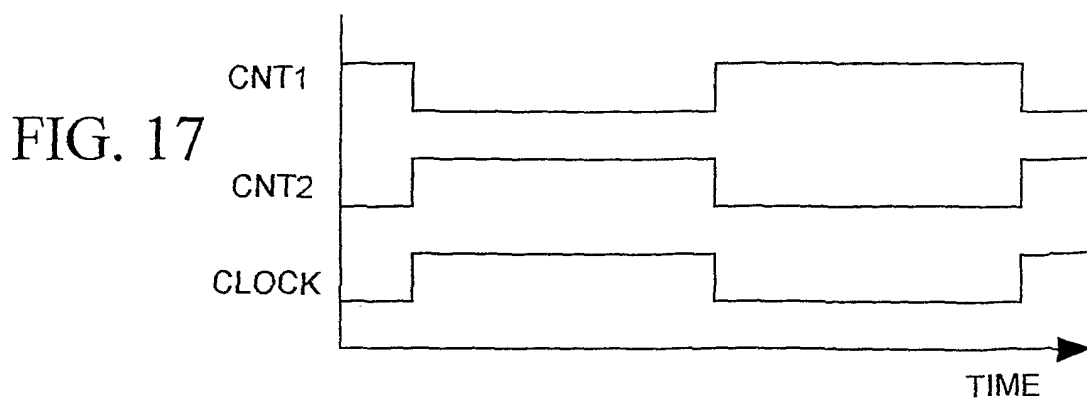

FIG. 17