

(19) World Intellectual Property Organization
International Bureau



(43) International Publication Date
18 June 2009 (18.06.2009)

PCT

(10) International Publication Number
WO 2009/074844 A1

(51) International Patent Classification:
A61B 17/42 (2006.01)

(74) Agent: THURGOOD, Alexander; Cabinet Michel Richebourg, Le Clos du Golf, 69, rue Saint-Simon, F-42000 Saint-Etienne (FR).

(21) International Application Number:
PCT/IB2007/004428

(81) Designated States (unless otherwise indicated, for every kind of national protection available): AE, AG, AL, AM, AT, AU, AZ, BA, BB, BG, BH, BR, BW, BY, BZ, CA, CH, CN, CO, CR, CU, CZ, DE, DK, DM, DO, DZ, EC, EE, EG, ES, FI, GB, GD, GE, GH, GM, GT, HN, HR, HU, ID, IL, IN, IS, JP, KE, KG, KM, KN, KP, KR, KZ, LA, LC, LK, LR, LS, LT, LU, LY, MA, MD, ME, MG, MK, MN, MW, MX, MY, MZ, NA, NG, NI, NO, NZ, OM, PG, PH, PL, PT, RO, RS, RU, SC, SD, SE, SG, SK, SL, SM, SV, SY, TJ, TM, TN, TR, TT, TZ, UA, UG, US, UZ, VC, VN, ZA, ZM, ZW.

(22) International Filing Date:
12 December 2007 (12.12.2007)

(25) Filing Language: English

(26) Publication Language: English

(71) Applicant (for all designated States except US): VECTEC [FR/FR]; Bioparc, F-03270 Hauterive (FR).

(84) Designated States (unless otherwise indicated, for every kind of regional protection available): ARIPO (BW, GH, GM, KE, LS, MW, MZ, NA, SD, SL, SZ, TZ, UG, ZM, ZW), Eurasian (AM, AZ, BY, KG, KZ, MD, RU, TJ, TM), European (AT, BE, BG, CH, CY, CZ, DE, DK, EE, ES, FI, FR, GB, GR, HU, IE, IS, IT, LT, LU, LV, MC, MT, NL, PL,

(72) Inventors; and
(75) Inventors/Applicants (for US only): D'ARPIANY, Francis [FR/FR]; 40, rue Capitaine Selvez, F-03110 Vendat (FR). ARBOY, Yves [FR/FR]; 4, villa Sainte-Foy, FR-92200 Neuilly sur Seine (FR).

[Continued on next page]

(54) Title: SINGLE USE, DISPOSABLE, UTERINE MANIPULATOR AND METHOD OF USE

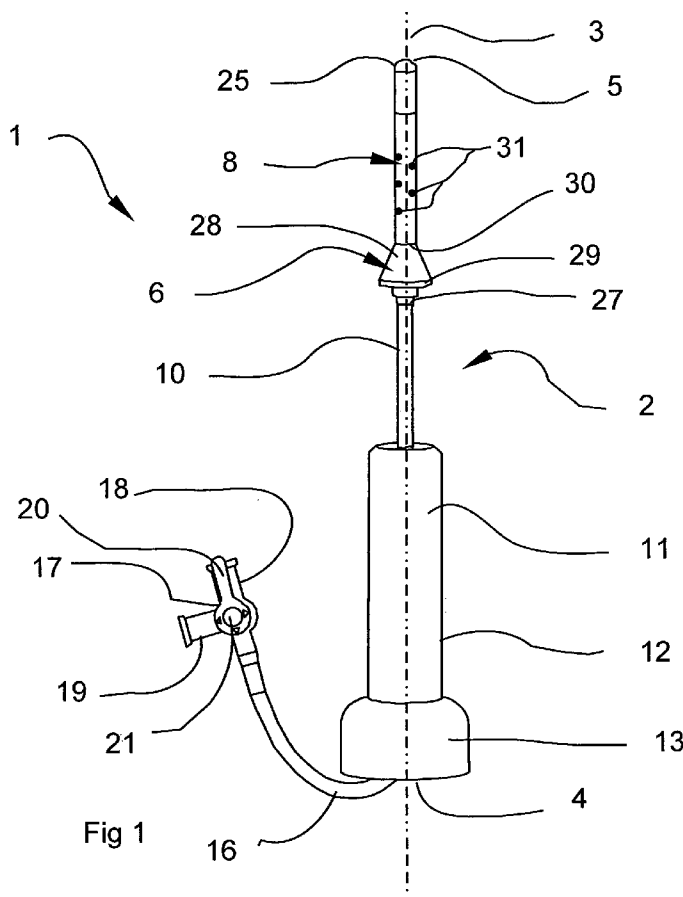

(57) Abstract: The present invention relates to single use, disposable, uterine manipulator device and methods for use thereof. The device comprises a tubular elongate portion defining a longitudinal axis of the device, and having a proximal and a distal extremity, wherein the distal extremity is provided with sealing abutment means for sealingly abutting the cervix, and the distal extremity is further provided with uterine wall suction means distributed around the distal extremity for providing suction to the device, thereby enabling said device to come into suction contact with an inner uterine wall.

WO 2009/074844 A1



PT, RO, SE, SI, SK, TR), OAPI (BF, BJ, CF, CG, CI, CM,
GA, GN, GQ, GW, ML, MR, NE, SN, TD, TG).

Declaration under Rule 4.17:

— *of inventorship (Rule 4.17(iv))*

Published:

— *with international search report*

Single use, disposable, uterine manipulator and method of use.

The present invention relates to single use, disposable surgical instruments in general, and more particularly to a device for manipulating a uterus that is particularly adapted to use in
5 coelioscopic surgery.

One of the current problems encountered in coelioscopic surgery in female patients is the position that the female reproductive organs, and in particular the uterus, the fallopian tubes and ovaries, adopt because of the way the patient is laid out on the operating table. This position, know as the Trendelenburg position, causes the female reproductive organs to fall back into the
10 Douglas' pouch or rectouterine excavation, thereby making access to that pouch difficult or impossible for the surgeon. Several attempts have been made to produce devices that would assist the surgeon in gaining access to the Douglas' pouch more easily, most of which involve inflicting some kind of trauma on the female reproductive organs.

For example, one known device comprises a frustoconical screw-threaded plug that is screwed
15 into the cervix of the female patient, in order to permit manipulation of the uterus, and thereby enable the surgeon to position the uterus as desired during surgery. The problem with a device such as this is that the screw thread bites into the cervical wall, and inevitably causes a certain degree of trauma. It has been noticed in general that trauma to the cervical wall, in whatever form, can lead to reduced fertility, especially in younger female subjects, and so it would be
20 desirable to avoid, where possible, inflicting any such trauma.

Another example of a device for uterine manipulation involves an inflatable balloon, that is provided at a distal tip of a manipulator. The manipulator is inserted into the uterus via the vagina, and the balloon inflated so that the exterior walls of the balloon come into pressure contact with the inner walls of the uterus. The idea is that the expansion of the balloon causes
25 sufficient friction against the inner uterine wall to enable the surgeon to operate the manipulator and thereby displace the uterus in the desired direction. However, in order to be effective, the device must generally be inserted into the uterus until it meets with the upper inner wall of the latter, and then the balloon inflated, and the pressure thereby exerted by the balloon can cause localised damage to the uterine inner wall.

30 The device according to the present invention attempts to overcome the above limitations, whilst at the same time being easy to use and operate, and most notably, being atraumatic, i.e. not

inflicting trauma on the inner wall of the uterus or the cervical wall.

Accordingly, one object of the present invention is a single use, disposable uterine manipulator device, comprising :

- 5 – a tubular elongate portion defining a longitudinal axis of the device, and having a proximal and a distal extremity ;
 - wherein the distal extremity is provided with sealing abutment means for sealingly abutting the cervix, and the distal extremity is further provided with uterine wall suction means distributed around the distal extremity for providing suction to the device, thereby enabling said device to come into suction contact with an inner uterine wall.
- 10 Preferably, the tubular elongate portion is made of a sterilisable material, preferably stainless steel, however other materials may also provide satisfaction, provided that they are suitable for use in a surgical instrument, are suitably rigid and can be sterilised.

15 In one preferred embodiment, the sealing abutment means and the uterine wall suction means are formed integrally as a sleeve that fits over the distal extremity of the tubular elongate portion. It is of course possible to envisage that the sealing abutment means and the uterine wall suction means be separate elements mounted on the tubular elongate portion such that they perform their function appropriately.

20 Preferably, the sleeve of the uterine wall suction means is made of a sterilisable polymer material, and even more preferably of a polymer material selected from the group consisting of polyoxymethacrylate, polyacetal, and PA66.

25 In accordance with another preferred embodiment, the tubular elongate portion is open at the distal extremity and together with an inner surface of the sleeve mentioned above defines a space allowing for the passage of fluid. The passage of fluid can be simply formed by providing for a difference in diameter between the outside diameter of the tubular elongate portion and the inner diameter of the sleeve, and leaving the distal extremity of the tubular elongate portion free or unblocked, such that fluids may pass either into the distal extremity of the elongate portion, for example, air being withdrawn under vacuum, or in the opposite direction, for example, when a liquid, such as a contrast or washing agent, is injected from the proximal end of the tubular elongate portion.

The sleeve also preferably comprises a plurality of suction orifices which traverse a wall of the sleeve and communicate with the space allowing for passage of fluid. This plurality of orifices is even more preferably distributed about the sleeve in a manner enabling a sufficient portion of the sleeve to come into suction contact with an inner uterine wall. Thus the plurality of orifices
5 forms, along with the space created between the sleeve and elongate tubular portion, a way of creating fluid communication between an inner wall of the uterus, and the outside environment, i.e. the environment outside of the uterus.

Where fluid communication to be created is in the form of vacuum or suction, such suction is preferably provided at a vacuum pressure comprised between 0.4 bar and 0.8 bar, and most
10 preferably is about 0.6 bar. The applicant has noticed that this latter value is completely atraumatic for the tissue of the uterus, including the inner walls of the uterus to which the device becomes attached when vacuum or suction is applied through the device.

Even more preferably, the device sleeve comprises a total of 8, or most preferably 10 orifices, distributed evenly about the sleeve in a 3-2-3, or respectively, a 3-2-3-2 configuration. Such a
15 configuration allows for optimal coverage of the inner uterine wall surfaces, thereby facilitating manipulation of the uterus when vacuum is being applied.

It will be understood from the above, that the sleeve can preferably have a section that widens from a proximal end towards a distal end of said sleeve.

The sealing abutment means are designed to abut, in a sealing manner, the cervix, and thus it is
20 preferred that they be located at a proximal end of the sleeve, and have a section that is substantially conical, adapted in shape and size to sealingly abut a cervix, and extending from a widened proximal end to a narrowed distal end which abuts or adjoins the proximal end of the sleeve. It is to be noted that since the sealing abutment means are substantially conical, the nose or distal end formed thereby can preferably be snubbed or rounded, to enable a less traumatic
25 contact with the cervix. One should note here the complete contrast with prior art solutions involving a screw thread which engages the tissue of the cervix and can cause damage thereto.

In one advantageous embodiment, the device further preferably comprises grip means, mounted in axial sliding engagement around the tubular elongate portion, proximal to the uterine wall suction means and sealing abutment means, and distal to the proximal extremity of the tubular
30 elongate portion. Preferably, the grip means are mounted in fixed rotating engagement about the tubular elongate portion, but they can also be made to rotate in and out of a locked position,

should that be desired. It can thus be seen that the tubular elongate portion bearing the uterine wall suction means can slide along inside the grip means, while leaving an exterior grip surface free for the surgeon to manipulate the device, for example, rotating it in one direction or another.

Even more preferably, the device also comprises a Luer lock 2-way valve located at the proximal
5 extremity the tubular elongate portion. Such a 2-way Luer lock preferable provides :

- in a first open position, for a fluid communication between the elongate tubular portion and the uterine wall suction means,
- in a second position, for complete obstruction of the Luer lock.

In still yet another preferred embodiment, the device further comprises hysterectomy guide
10 means. These guide means are used to aid the surgeon in performing a hysterectomy, either a sub-total hysterectomy or a total hysterectomy, depending on how much of the cervix is removed along with the uterus. Preferably, the hysterectomy guide means comprises an adapter comprising engagement means to engage the proximal end of the sealing abutment means, and ablation guide sleeve which is adapted to engage at least partially circumferentially an exterior
15 wall of the cervix. Even more preferably, the adapter has clips means for removably engaging a proximal surface of the sealing abutment means. It can thus be seen that the adapter slides over the sealing abutment means and can be clipped and retained at a proximal end of the sealing abutment means. Where the adapter is made of resilient or slightly elastic material, it is preferably designed to elastically fit over the substantially conical sealing abutment means and
20 then snap back over a proximal circumference or periphery of said sealing abutment means.

As a result, it is preferred that the adapter also be substantially conical in shape, extending from a widened proximal end towards a narrowed distal end, the shape defined thereby enabling sealing abutment of the adapter with an inner vaginal wall. Thus, the initial cervical sealing abutment means no longer serve their purpose, since they are covered, in this particular embodiment, by
25 the adapter, which is dimensioned to provide sealing abutment with an inner vaginal wall and not the cervix.

In a further preferred embodiment, the ablation guide sleeve is substantially tubular, in order to be able to be slid over the device as described initially, but also comprises a peripheral projecting wall, which extends from a proximal end in abutment with the distal end of the adapter, towards
30 a distal end, wherein the projecting wall engages at partially circumferentially an exterior wall of the cervix. In this way, the projecting wall serves as a guide for the surgeon as to where the tissue

of the cervix should be sectioned and removed along with the rest of the uterus.

In still yet another object of the invention, there is provided a method of manipulating an inner wall of a uterus, comprising the steps consisting of :

- 5 - inserting a uterine manipulator device comprising a tubular elongate portion defining a longitudinal axis of the device, and having a proximal and a distal extremity, wherein the distal extremity is provided with sealing abutment means for sealingly abutting the cervix, and the distal extremity is further provided with uterine wall suction means distributed around the distal extremity for providing suction to the device ;
- 10 - applying suction vacuum pressure to the device to activate suction via the uterine wall suction means, thereby enabling said device to come into suction contact with an inner uterine wall ;
- moving the device into a desired position, whereby the suction applied via the uterine wall suction means causes the uterus to be moved correspondingly with the device.

15 The invention also provides for a method for performing a contrast diagnostic test in a female reproductive organ, comprising the steps consisting of :

- introducing a uterine manipulation device as described above into a uterus to obtain sealing abutment of the device with a cervix ;
- setting a Luer lock on the uterine manipulator device to a position whereby vacuum suction communication is obstructed and yet still allowing another fluid to be introduced into said 20 device ; and
- introducing via said Luer lock a contrast agent that flows through the device and into the uterus.

In addition, still yet another preferred object is a method for performing a hysterectomy, comprising the steps consisting of :

- 25 - introducing a device as described above into a uterus, whereby an adapter comes into sealing abutment with an inner vaginal wall, and a ablation guide sleeve comes into at least a partial circumferential engagement with an exterior wall of a cervix ;

- using a distal extremity of the ablation guide sleeve as a guide to determine the limit of ablation of said uterus.

Other objects and preferred embodiments will become apparent through the detailed description and the figures, given purely for illustrative purposes, as follows :

5 Brief Description of the Figures

Figure 1 is schematic representation of a single use, disposable, uterine manipulation device according to the present invention ;

Figure 2a, 2b and 2c are different schematic views of a distal part of the uterine manipulation device illustrated in Figure 1 ;

- 10 Figure 3 is a first representation of the introduction into a uterus of the device of Figure 1 ;

Figure 4 is a second representation of the normal final position of the device of Figure 1 once fully introduced into the uterus ;

Figures 5a, 5b and 5c are different schematic representations of a further adapter for the device of the present invention ;

- 15 Figure 6 is a schematic representation of an extra component that fits onto the adapter illustrated in Figure 5, and which is suited to assisting a surgeon in carrying out a hysterectomy.

Examples, or Detailed Description of the Invention

- As can be seen from Figure 1, the single use, disposable, uterine manipulation device, indicated by the general reference 1, comprises a tubular elongate portion, identified by the general
20 reference 2, defining a longitudinal axis 3 of the device 1, and having a proximal 4 and a distal extremity 5. The distal extremity 5 is provided with sealing abutment means, indicated generally by the reference 6, for sealingly abutting a cervix 7 (cf. Figures 3 and 4), and the distal extremity 5 is further provided with uterine wall suction means 8 distributed around the distal extremity 5 for providing suction to the device 1, thereby enabling the device 1 to come into suction contact
25 with an inner uterine wall 9. The tubular elongate portion 2 is made of a sterilisable, surgically appropriate material, preferably stainless steel, and thus generally takes the shape of a stainless steel tube 10. The tube 10 is essentially hollow along the axis 3 and has an opening at both the proximal 4 and distal 5 extremities. Figure 1 also shows that the device 1 further comprises grip

means, indicated generally by the reference 11, mounted in axial sliding engagement around the tubular elongate portion 2, proximal to the uterine wall suction means 8 and sealing abutment means 6 and distal to the proximal extremity 4 of the tubular elongate portion 2. The grip means 11 are mounted in fixed rotating engagement about the tubular elongate portion 2. As can be seen from Figure 1, the grip means 11 comprise a fairly large outer diameter tube 12. The tube can optionally be provided with ridges, not illustrated in the figure, to facilitate prehension by the operator of the device 1. The grip means 11 further include an enlarged, approximately funnel-shaped, proximal extremity 13, enabling other instruments to be introduced into the tube 12 if necessary. Since the grip means 11 are rotatively, but not slidingly locked, about the axis 3 of the device, it is possible to manipulate the device by rotating the tube 12 about said axis. It is furthermore possible to slide the sealing abutment means 6 and uterine wall suction means 8 along the axis 3 to introduce the latter into, and out of, the vagina 14 towards the uterus 15. The proximal extremity 4 of the device 1 is connected to a fluid communication conduit 16. The conduit 16 is made of a flexible fluid impermeable polymer material, of the type commonly used in hospitals or other surgical devices for the passage of fluids, be they liquids or gases. The fluid communication conduit 16 is connected to a Luer lock valve 17, having two ports 18, 19. A first port 18 is connected to a vacuum generator device or apparatus (not shown), for establishing vacuum or suction, such that air is sucked in via the uterine wall suction means 8, through the distal extremity 5 of the device 1, and then along the tubular elongate portion 2 and through the conduit 16 and first port 18. A second port 19 is provided for introduction and removal of another fluid, for example, a contrast agent such as methylene blue, which can be injected as a liquid through the second port 19 and into the uterus 15 via the device 1 by following the same schema as above, but in a reverse direction. The 2-way Luer lock valve 17 thus provides, in a first open position, for a fluid communication between the elongate tubular portion 2 and the uterine wall suction means 8, and in a second position, for complete obstruction of the Luer lock 17. The 2 Luer lock valve 17 thus also comprises a switch or lever 20, which can be activated to set the lock in a desired position, depending on whether the operator of the device 1 wants the fluid communication to be vacuum or suction in the first case, fluid communication for the introduction of a contrast agent, in a second case, and of course a third position, whereby all fluid communication is obstructed. In order to facilitate recognition of the position in which the lock 17 is set, the lock can be provided with markings 21, arranged on the lever 20, and indexed therewith.

As can be seen in more detail from Figure 2, the sealing abutment means 6 and the uterine wall suction means 8 are formed integrally as a sleeve 32 that fits over the distal extremity 5 of the

tubular elongate portion 2. Figure 2a shows a cross-section of the sleeve 32, along axis 3 of the device, clearly showing that the sleeve is hollow, and has an outer wall 22 and inner wall 23, defining an inner bore or space 24. The distal end 25 of the sleeve is blind, i.e. closed, and the distal limit 26 of the bore or space 24 has a generally concave shape, such that a distal end of the stainless steel tube 10 does not sealingly abut said limit 26, thereby allowing for passage of fluid between an opening in the distal end of the tube 10, and the space 24 of the sleeve. Additionally, as can be seen from Figure 2b, the sleeve does not have a circular cross-section, but extends from proximal end 27 towards the distal end 25 of the sleeve in a slightly widening cross-section, thereby ensuring that a fluid communication space 24 will be created between the stainless steel tube 10 and the inner wall 23 of the sleeve 32, and that the tube 10 will be held in elastic sealing engagement with the proximal end 27. The sealing abutment means 6 are located at a proximal end 27 of the sleeve 32, and has a cross-section substantially forming a cone 28, adapted in shape and size to sealingly abut a cervix. The cone 28 extends from a widened proximal end 29 to a narrowed distal end 30 which abuts or adjoins the sleeve 32. The uterine wall suction means 8 also comprise a plurality of orifices 31, distributed evenly around the sleeve 32, preferably in a 3-2-3-2 configuration or arrangement, as can be seen partially from Figure 2c. The orifices 31 traverse the outer and inner walls 22, 23 of the sleeve, and open into the fluid communication space 24. Thus, when vacuum is applied via the Luer lock port 18, air is withdrawn from within the device and a depression created that causes a uterine wall 9 to be sucked onto the sleeve 32. In a converse manner, when fluid, such as a contrast agent, is introduced via port 19, said fluid can pass through the device, into the space 24 and through the orifices into the uterus 15. As the cone sealingly abuts the cervix 7 of the uterus 15, no leakage in the sealtight environment can occur, and thus the vacuum pressure is maintained, or respectively, the fluid introduced into the uterus 15 remains therein or will permeate through the tissues therein or other organs connected thereto.

Turning now to Figure 3, one can see a schematic representation of female human reproductive organs, indicated by the general reference 33. These organs are represented generally by the ovaries 34, 35, the fallopian tubes 36, 37, the uterine cavity 38, the cervix 7, the uterine isthmus 40, and the vagina 14. The vagina 14 and uterus are shown here on the right hand side in a partial cut-away representation, in order to show the uterine cavity 38 and inner 39 and outer vaginal 41 walls and inner uterine 9 walls. In Figure 3, one can see that the device has been introduced via the vagina 14 and the cervix into the uterus 14, such that the distal end 25 of the sleeve 32 has reached the uterine isthmus 40. In this position, the device 1 of the invention is not yet ready for use.

Figure 4 shows, in a schematic representation, the position of the device I of the invention, once introduction thereof into the uterus 15 has been completed. In this figure, it can be seen that the distal end 30 of the cone 28 of the sealing abutment means has come into sealing abutment engagement with the cervix 7, forming a substantially leaktight seal. One will also note that the sleeve 32 has now been pushed past the uterine isthmus 40, such that the distal end 25 of the sleeve 32 is located in the uterine cavity 38. The plurality of orifices 31 of the suction means 8 are now in physical contact with an inner uterine wall 9. In Figure 4, the Luer lock port 18 is shown in the closed position, but when the lever 20 is moved and set to the open position, i.e. in this particular example by turning the lever through 90 degrees so that it lies over the second port 19, then vacuum pressure that can be applied will suck out any air in the device, creating a depression in the space 24 between the inner wall of the sleeve 32 and stainless steel tube and thereby causing a drop in pressure at the orifices 31, which in turn will cause the inner uterine wall 9 to be sucked onto the outer wall 22 of the sleeve 32. It thus becomes possible to manipulate the uterus 15 and associated organs and put them into a position more suitable for the surgeon, simply by moving the device around in the three-dimensional anatomical space. In this way, it also makes the Douglas' pouch accessible to the surgeon, should that be required. The seal is maintained by the conical shape of the cone 28 which abuts sealingly against the cervix 7, independently of the angle of inclination of the device. In a similar manner, a diagnostic test, for example, the methylene blue test, can be carried out very simply by activating the lever 20 again, to set the Luer lock port 18 into the closed position, for example, by either moving the lever 20 forward again by 90 degrees, or by reversing the initial movement. This movement will then open port 19, through which the methylene blue contrast agent can be injected. As there is a leaktight seal against the cervix 7, none of the fluid introduced can escape and will therefore diffuse in a classical manner through the various tissues, and particularly up the fallopian tubes to the ovaries, where the contrast agent will become visible through a coelioscope.

Turning now to Figures 5 and 6, these are schematic representations of a further embodiment of the device of the present invention, in which said uterine manipulator device I can be adapted to guide the surgeon who needs to carry out a hysterectomy, be it a total or sub-total hysterectomy. Consequently, the device I further comprises hysterectomy guide means, indicated by the general reference 42 comprises an adapter 43 comprising engagement means 44 to engage the proximal end 27 of the sealing abutment means 6, and ablation guide sleeve 45 which is adapted to engage at least partially circumferentially an exterior wall 46 of the cervix 7. The adapter 43 preferably has clip means 47 for removably engaging a proximal surface 48 of the sealing abutment means 6. In Figure 5, it can be seen that the adapter 43 has lands or cut-outs 49, which

form wings 50 in the adapter 43 and enable it to be slid over the cone 28 via the distal end of the sealing abutment means 6. Since the adapter is preferably made of resilient or elastic material, the wings 50 spread as the adapter 43 is slid over the cone 28 towards the widened proximal end 29 of the latter. The clip means 47, which can for example be one or more radial flanges 51
5 provided on the wings 50, then reach over the widened proximal end 29 of the cone and clip into place on a contact surface 48 which is essentially the proximal surface of the widened proximal end 29. Such a clipping action provides for sufficient maintainance of the adapter 43 in position, whilst at the same time allowing for its release simply by easing a radial flange back over onto the cone 28. Consequently, the adapter 43 is preferably substantially conical in shape, extending
10 from a widened proximal end 52 towards a narrowed distal end 53, the shape defined thereby enabling sealing abutment of the adapter 43 with an inner vaginal wall 39. The ablation guide sleeve 45 also comprises a peripheral projecting wall 54, which extends from a proximal end 55 in abutment with the distal end 53 of the adapter 43, towards a distal end 56, wherein the projecting wall 54 engages partially circumferentially an exterior wall of the cervix 46. In this
15 way, the projecting wall 54 serves to guide the surgeon wishing to remove the uterus 15 down to a limit on the cervix 7 that is defined by the extent of the projecting peripheral wall 54.

Claims

- 1) Single use, disposable, uterine manipulator device, comprising :
- a tubular elongate portion defining a longitudinal axis of the device, and having a proximal and a distal extremity ;
 - wherein the distal extremity is provided with sealing abutment means for sealingly abutting a cervix, and the distal extremity is further provided with uterine wall suction means distributed around the distal extremity for providing suction to the device, thereby enabling said device to come into suction contact with an inner uterine wall.
- 2) Uterine manipulator device according to claim 1, wherein the tubular elongate portion is made of a sterilisable material, preferably stainless steel.
- 3) Uterine manipulator device according to claim 1, wherein the sealing abutment means and the uterine wall suction means are formed integrally as a sleeve that fits over the distal extremity of the tubular elongate portion.
- 4) Uterine manipulator device according to claim 3, wherein the sleeve is made of a sterilisable polymer material, preferably selected from the group consisting of polyoxymethacrylate, polyacetal, and PA66.
- 5) Uterine manipulator device according to any of claims 1 to 4, wherein the tubular elongate portion is open at the distal extremity and together with an inner surface of the sleeve defines a space allowing for the passage of fluid.
- 6) Uterine manipulator device according to any of the preceding claims, wherein the sleeve comprises a plurality of suction orifices which traverse a wall of the sleeve and communicate with the space allowing for passage of fluid.
- 7) Uterine manipulator device according to claim 6, wherein the plurality of orifices is distributed about the sleeve in a manner enabling a sufficient portion of the sleeve to come into suction contact with an inner uterine wall.
- 8) Uterine manipulator device according to any of the preceding claims, wherein the suction

is provided at a vacuum pressure comprised between 0.4 bar and 0.8 bar, and preferably is about 0.6 bar.

- 5 9) Uterine manipulator device according to any of the preceding claims, wherein the sleeve comprises a total of 8 orifices, distributed evenly about the sleeve in a 3-2-3 configuration, or even more preferably 10 orifices, distributed evenly about the sleeve in a 3-2-3-2 configuration.
- 10) Uterine manipulator device according to any of the preceding claims, wherein the sleeve has a cross-section that widens from a proximal end towards a distal end of said sleeve.
- 10 11) Uterine manipulator device according to any of the preceding claims, wherein the sealing abutment means are located at a proximal end of the sleeve, and has a section that is substantially conical, adapted in shape and size to sealingly abut a cervix, and extending from a widened proximal end to a narrowed distal end which abuts or adjoins the sleeve.
- 15 12) Uterine manipulator device according to any of the preceding claims, wherein the device further comprises grip means, mounted in axial sliding engagement around the tubular elongate portion, proximal to the uterine wall suction means and sealing abutment means and distal to the proximal extremity of the tubular elongate portion.
- 13) Uterine manipulator device according to any of the preceding claims, wherein the grip means are mounted in fixed rotating engagement about the tubular elongate portion.
- 20 14) Uterine manipulator device according to any of the preceding claims, wherein the device further comprises a Luer lock 2-way valve located at the proximal extremity the tubular elongate portion.
- 15) Uterine manipulator device according to claim 14, wherein the 2-way Luer lock provides :
- in a first open position, for a fluid communication between the elongate tubular portion and
25 the uterine wall suction means,
 - in a second position, for complete obstruction of the Luer lock.
- 16) Uterine manipulator device according to any of the preceding claims, wherein the device further comprises hysterectomy guide means.

- 17) Uterine manipulation device according to the preceding claim, wherein the hysterectomy guide means comprises an adapter comprising engagement means to engage the proximal end of the sealing abutment means, and ablation guide sleeve which is adapted to engage at least partially circumferentially an exterior wall of the cervix.
- 5 18) Uterine manipulation device according to the preceding claim, where in the adapter has clips means for removably engaging a proximal surface of the sealing abutment means.
- 19) Uterine manipulation device according to the preceding claim, wherein the adapter is substantially conical in shape, extending from a widened proximal end towards a narrowed distal end, the shape defined thereby enabling sealing abutment of the adapter with an inner vaginal wall.
- 10 20) Uterine manipulation device according to any of the preceding claims 16 to 19, wherein the ablation guide sleeve comprise a peripheral projecting wall, which extends from a proximal end in abutment with the distal end of the adapter, towards a distal end, wherein the projecting wall engages partially circumferentially an exterior wall of the cervix.
- 15 21) Method of manipulating an inner wall of a uterus, comprising the steps consisting of :
- inserting a uterine manipulator device comprising a tubular elongate portion defining a longitudinal axis of the device, and having a proximal and a distal extremity, wherein the distal extremity is provided with sealing abutment means for sealingly abutting the cervix, and the distal extremity is further provided with uterine wall suction means distributed
- 20 around the distal extremity for providing suction to the device ;
- applying suction vacuum pressure to the device to activate suction via the uterine wall suction means, thereby enabling said device to come into suction contact with an inner uterine wall ;
 - moving the device into a desired position, whereby the suction applied via the uterine wall
- 25 suction means causes the uterus to be moved correspondingly with the device.
- 22) Method for performing a contrast diagnostic test in a female reproductive organ, comprising the steps consisting of :
- introducing a uterine manipulation device according to claim 1 into a uterus to obtain sealing

abutment of the device with a cervix ;

- setting a 2-way Luer lock on the uterine manipulator device to a position whereby vacuum suction communication is obstructed and yet still allowing another fluid to be introduced into said device ; and
- 5 - introducing via said Luer lock a contrast agent that flows through the device and into the uterus.

23) Method for performing a hysterectomy, comprising the steps consisting of :

- introducing a device according to any one of claims 1 to 20 into a uterus, whereby an adapter comes into sealing abutment with an inner vaginal wall, and a ablation guide sleeve comes
10 into at least a partial circumferential engagement with an exterior wall of a cervix ;
- using a distal extremity of the ablation guide sleeve as a guide to determine the limit of ablation of said uterus.

1 / 6

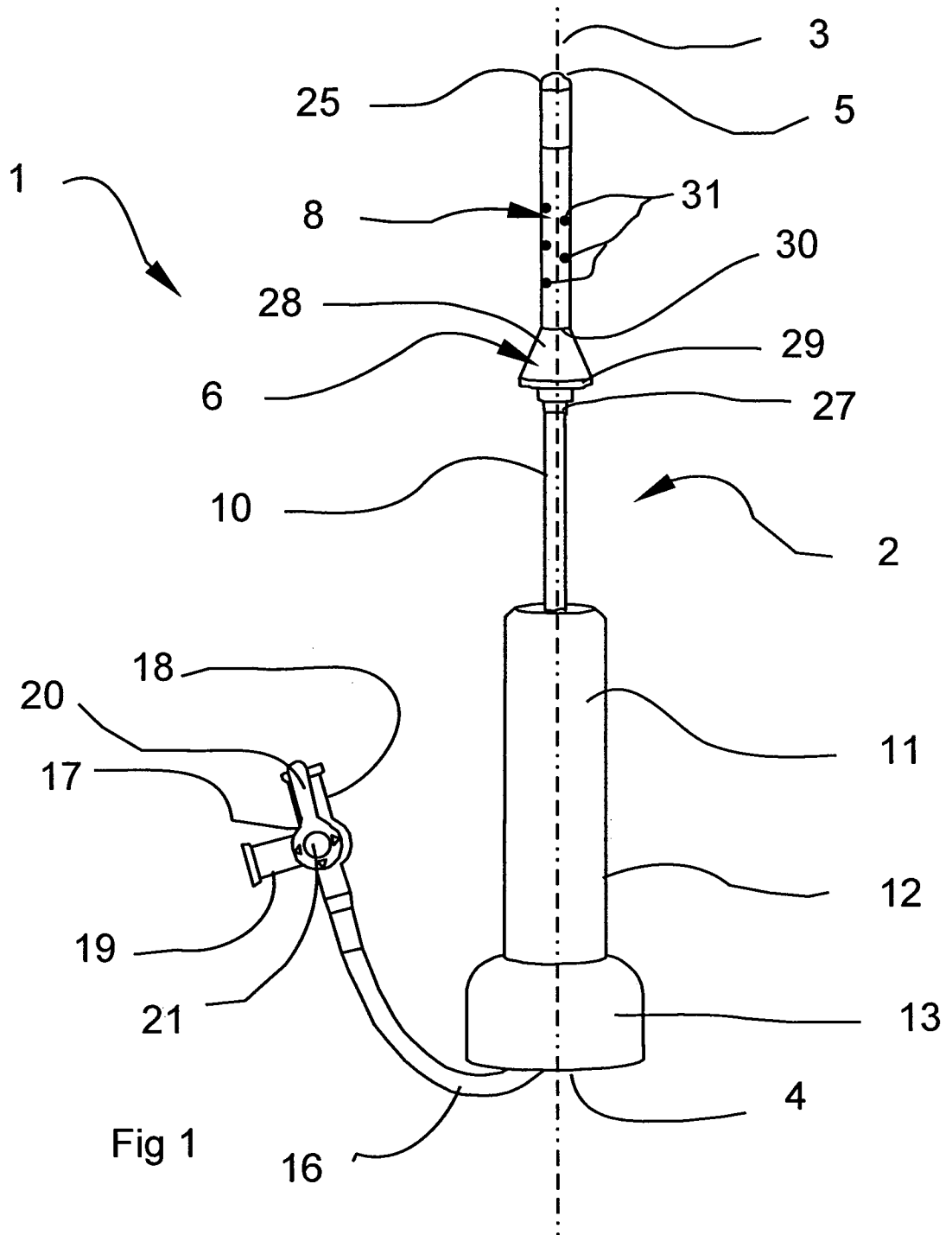

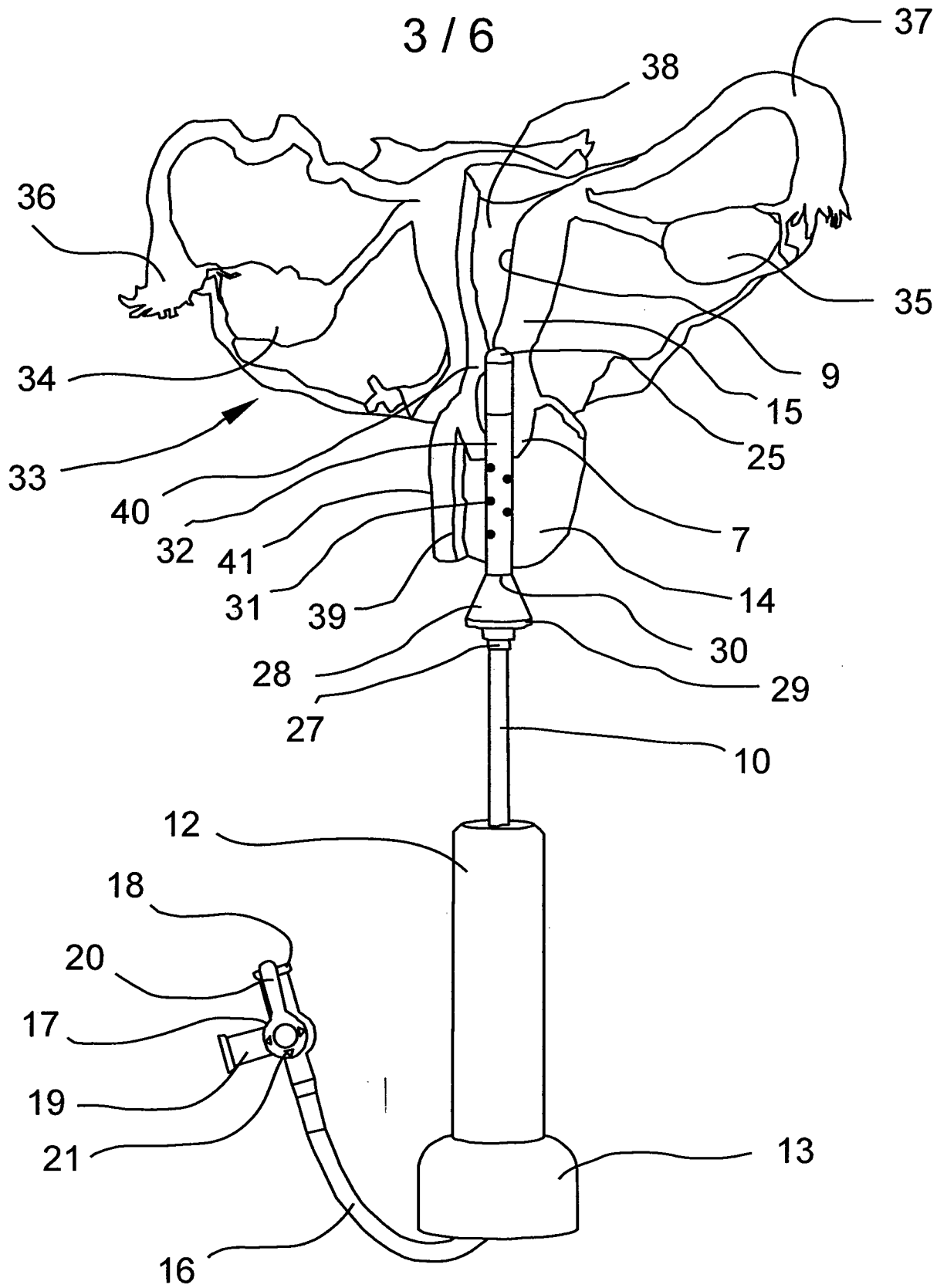

Fig 3

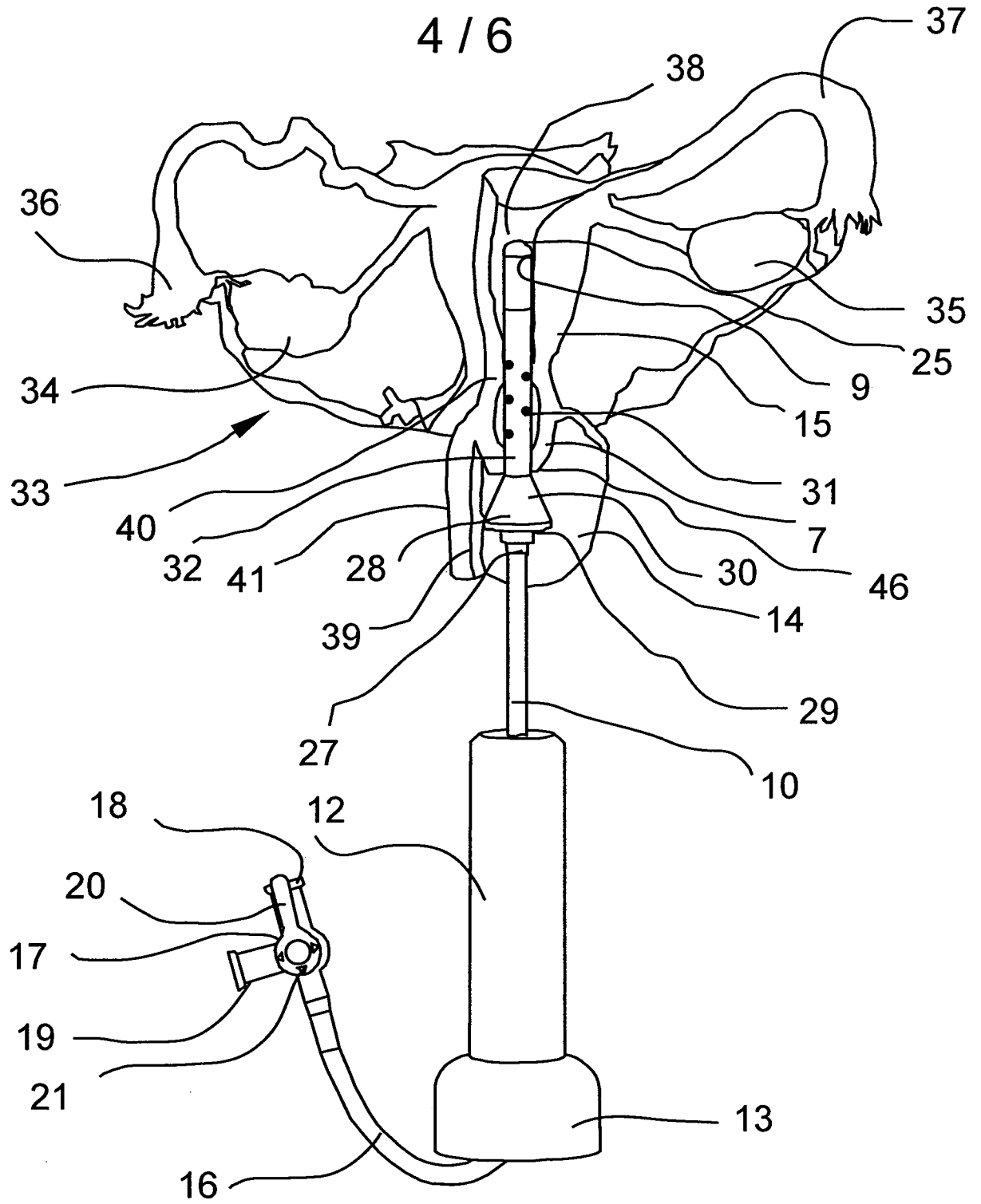

Fig 4

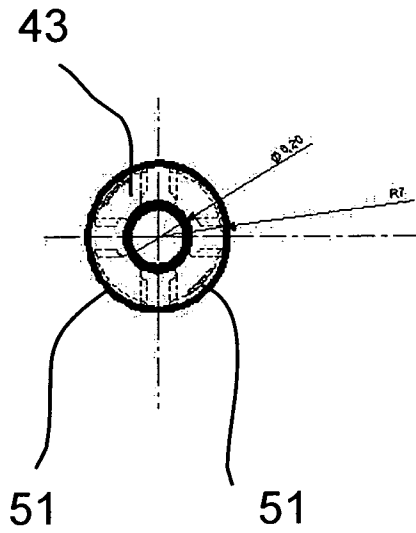

Fig 5a

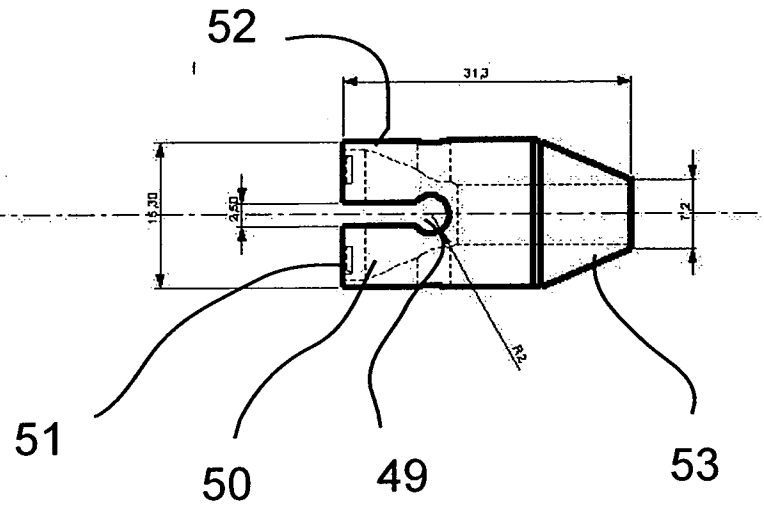

Fig 5b

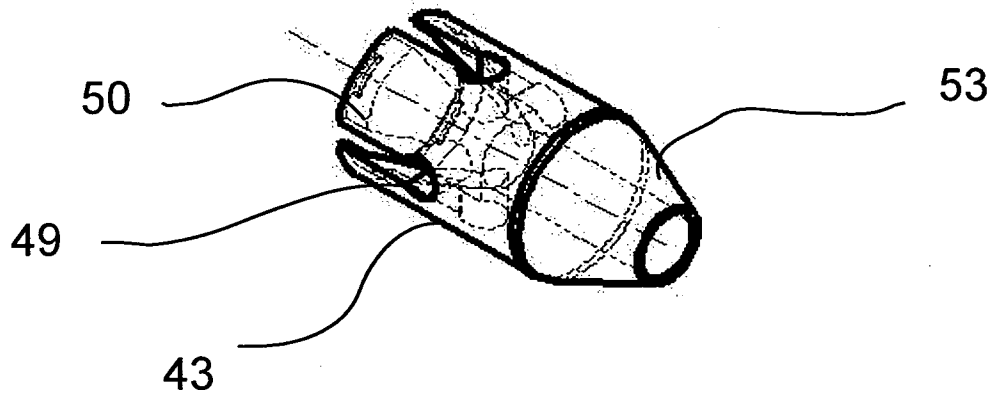

Fig 5c

6 / 6

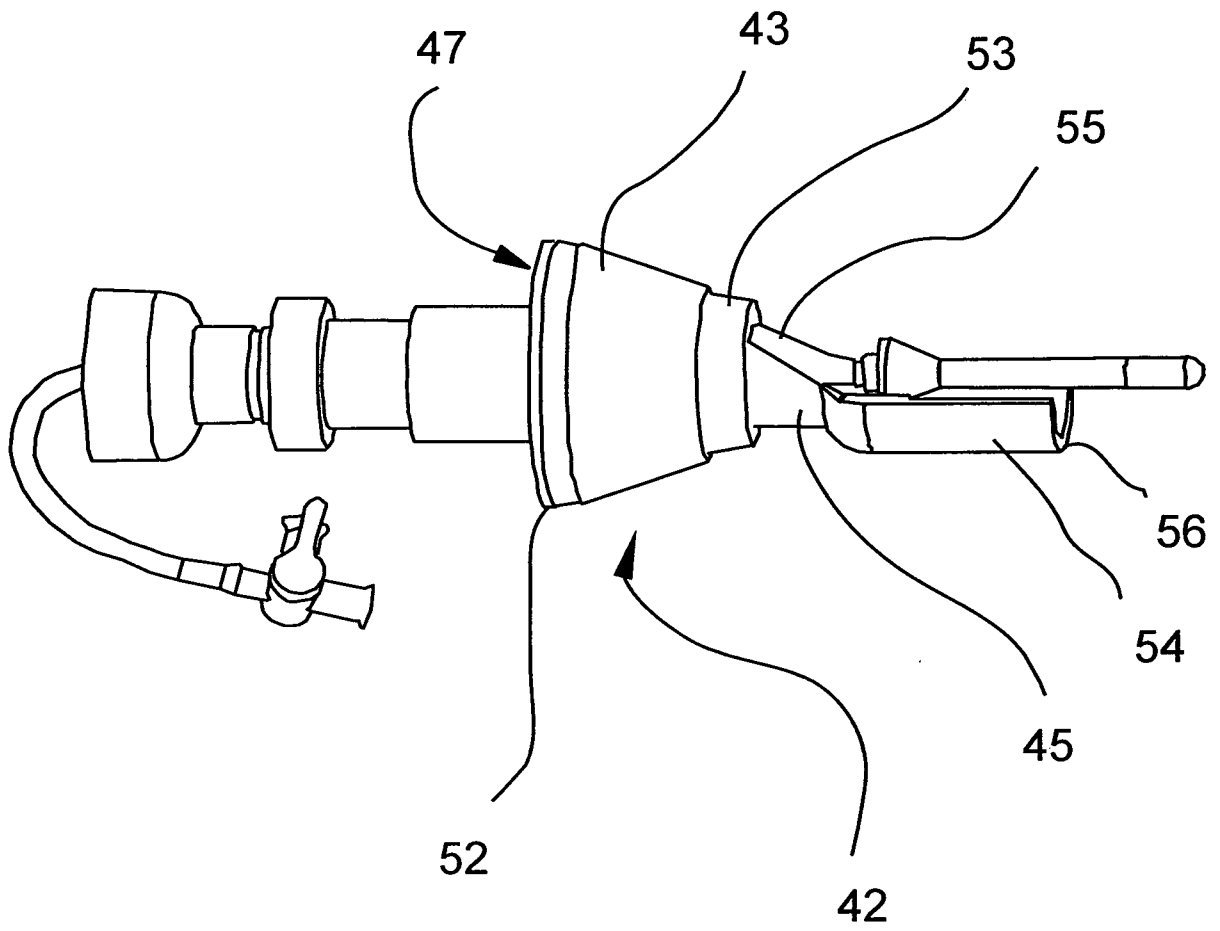

Fig 6

INTERNATIONAL SEARCH REPORT

International application No
PCT/IB2007/004428

A. CLASSIFICATION OF SUBJECT MATTER
INV. A61B17/42

According to International Patent Classification (IPC) or to both national classification and IPC

B. FIELDS SEARCHED

Minimum documentation searched (classification system followed by classification symbols)
A61B

Documentation searched other than minimum documentation to the extent that such documents are included in the fields searched

Electronic data base consulted during the international search (name of data base and, where practical, search terms used)
EPO-Internal

C. DOCUMENTS CONSIDERED TO BE RELEVANT

Category*	Citation of document, with indication, where appropriate, of the relevant passages	Relevant to claim No.
X	US 2 822 809 A (SOLLMANN) 11 February 1958 (1958-02-11) the whole document	1-9, 11, 14, 15
Y	-----	16-18
Y	US 5 746 750 A (PRESTEL ET AL.) 5 May 1998 (1998-05-05) abstract; figure 10 column 4, line 58 - column 5, line 19	16-18
X	US 1 245 845 A (WHITE) 6 November 1917 (1917-11-06) the whole document	1, 5-9, 14, 15
X	US 2 400 251 A (NAGEL) 14 May 1946 (1946-05-14) the whole document	1, 5-10, 12-15
	----- -/--	

Further documents are listed in the continuation of Box C.

See patent family annex.

- * Special categories of cited documents :
- *A* document defining the general state of the art which is not considered to be of particular relevance
 - *E* earlier document but published on or after the international filing date
 - *L* document which may throw doubts on priority claim(s) or which is cited to establish the publication date of another citation or other special reason (as specified)
 - *O* document referring to an oral disclosure, use, exhibition or other means
 - *P* document published prior to the international filing date but later than the priority date claimed
 - *T* later document published after the international filing date or priority date and not in conflict with the application but cited to understand the principle or theory underlying the invention
 - *X* document of particular relevance; the claimed invention cannot be considered novel or cannot be considered to involve an inventive step when the document is taken alone
 - *Y* document of particular relevance; the claimed invention cannot be considered to involve an inventive step when the document is combined with one or more other such documents, such combination being obvious to a person skilled in the art.
 - *Z* document member of the same patent family

Date of the actual completion of the international search 20 June 2008	Date of mailing of the international search report 01/07/2008
---	--

Name and mailing address of the ISA/ European Patent Office, P.B. 5818 Patentlaan 2 NL - 2280 HV Rijswijk Tel. (+31-70) 340-2040, Tx. 31 651 epo nl, Fax: (+31-70) 340-3016	Authorized officer Giménez Burgos, R
---	---

INTERNATIONAL SEARCH REPORT

International application No
PCT/IB2007/004428

C(Continuation). DOCUMENTS CONSIDERED TO BE RELEVANT		
Category*	Citation of document, with indication, where appropriate, of the relevant passages	Relevant to claim No.
X	US 3 777 743 A (BINARD ET AL.) 11 December 1973 (1973-12-11) abstract -----	1,6-9
X	US 3 766 907 A (MUENZER) 23 October 1973 (1973-10-23) the whole document -----	1-9,11
A	WO 96/11641 A (BLAIRDEN PRECISION INSTRUMENTS, INC.) 25 April 1996 (1996-04-25) the whole document -----	1,16-20
A	FR 2 745 171 A (HOURCABIE) 29 August 1997 (1997-08-29) the whole document -----	1,16-20

INTERNATIONAL SEARCH REPORT

International application No.
PCT/IB2007/004428

Box No. II Observations where certain claims were found unsearchable (Continuation of item 2 of first sheet)

This international search report has not been established in respect of certain claims under Article 17(2)(a) for the following reasons:

1. Claims Nos.: 21-23
because they relate to subject matter not required to be searched by this Authority, namely:
Rule 39.1(iv) PCT - Method for treatment of the human or animal body by surgery
2. Claims Nos.:
because they relate to parts of the International application that do not comply with the prescribed requirements to such an extent that no meaningful international search can be carried out, specifically:
3. Claims Nos.:
because they are dependent claims and are not drafted in accordance with the second and third sentences of Rule 6.4(a).

Box No. III Observations where unity of invention is lacking (Continuation of item 3 of first sheet)

This International Searching Authority found multiple inventions in this international application, as follows:

1. As all required additional search fees were timely paid by the applicant, this international search report covers allsearchable claims.
2. As all searchable claims could be searched without effort justifying an additional fees, this Authority did not invite payment of additional fees.
3. As only some of the required additional search fees were timely paid by the applicant, this international search report covers only those claims for which fees were paid, specifically claims Nos.:
4. No required additional search fees were timely paid by the applicant. Consequently, this international search report is restricted to the invention first mentioned in the claims; it is covered by claims Nos.:

Remark on Protest

- The additional search fees were accompanied by the applicant's protest and, where applicable, the payment of a protest fee.
- The additional search fees were accompanied by the applicant's protest but the applicable protest fee was not paid within the time limit specified in the invitation.
- No protest accompanied the payment of additional search fees.

INTERNATIONAL SEARCH REPORT

Information on patent family members

International application No

PCT/IB2007/004428

Patent document cited in search report		Publication date	Patent family member(s)	Publication date
US 2822809	A	11-02-1958	NONE	
US 5746750	A	05-05-1998	DE 19603981 A1	07-08-1997
US 1245845	A		NONE	
US 2400251	A	14-05-1946	NONE	
US 3777743	A	11-12-1973	AU 476710 B2 AU 6018973 A BE 805414 A1 CA 1004939 A1 DE 2348438 A1 FR 2201066 A1 GB 1405556 A IT 996210 B JP 1113761 C JP 49071793 A JP 57001258 B NL 7313206 A ZA 7307520 A	30-09-1976 13-03-1975 16-01-1974 08-02-1977 04-04-1974 26-04-1974 10-09-1975 10-12-1975 16-09-1982 11-07-1974 09-01-1982 02-04-1974 28-08-1974
US 3766907	A	23-10-1973	AU 458007 B2 AU 4082672 A BE 786542 A1 CH 534506 A DE 2235337 A1 FR 2146842 A5 GB 1333347 A IT 953652 B JP 55030859 B	10-01-1975 11-10-1973 22-01-1973 15-03-1973 01-02-1973 02-03-1973 10-10-1973 10-08-1973 14-08-1980
WO 9611641	A	25-04-1996	AT 258030 T AU 3953395 A DE 69532474 D1 DE 69532474 T2 EP 0786962 A1 JP 3772349 B2 JP 10507384 T US 5643285 A	15-02-2004 06-05-1996 26-02-2004 25-11-2004 06-08-1997 10-05-2006 21-07-1998 01-07-1997
FR 2745171	A	29-08-1997	NONE	