

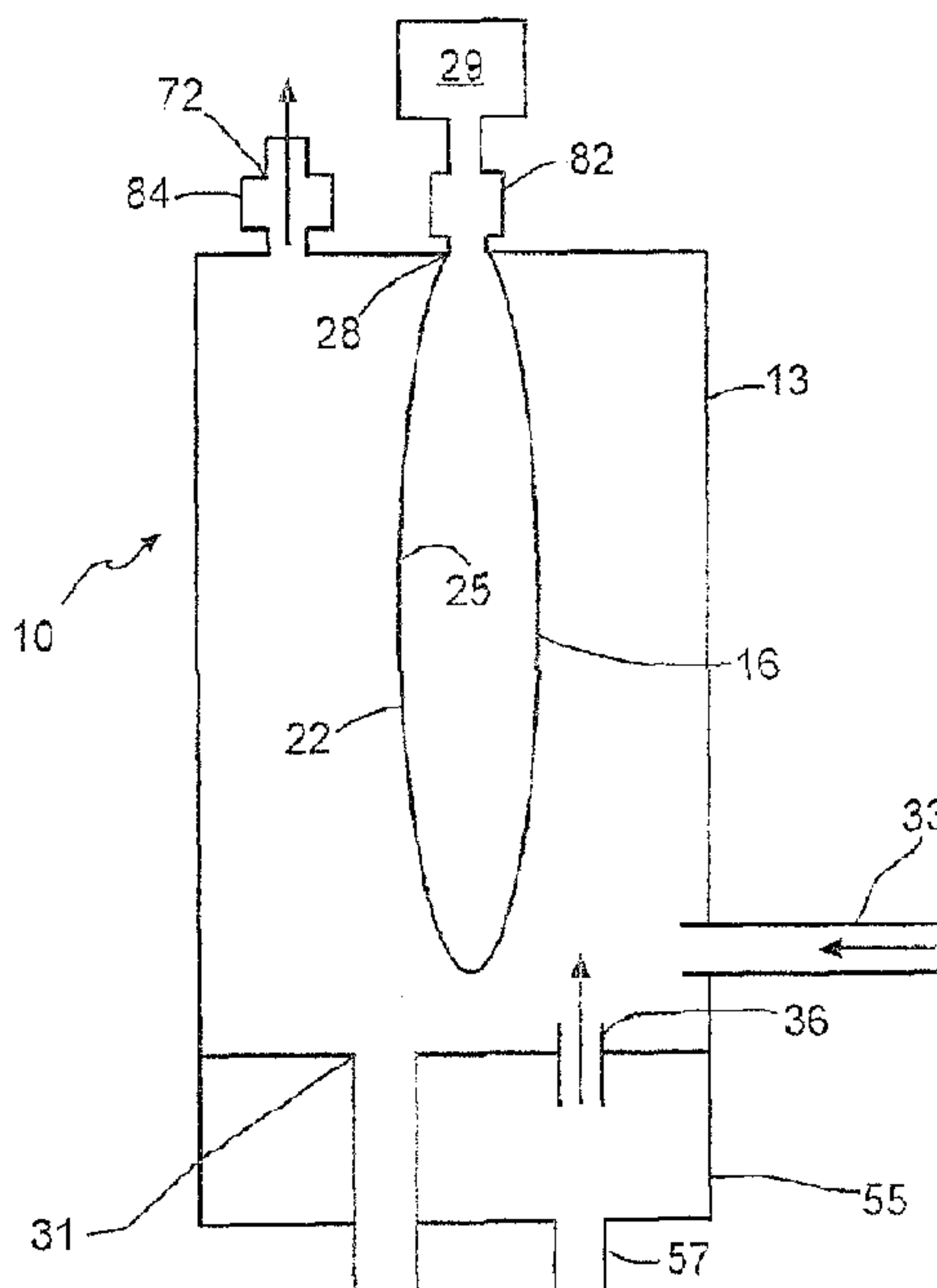

(22) Date de dépôt/Filing Date: 2008/08/22
 (41) Mise à la disp. pub./Open to Public Insp.: 2009/02/26
 (45) Date de délivrance/Issue Date: 2019/04/09
 (62) Demande originale/Original Application: 2 733 809
 (30) Priorités/Priorities: 2007/08/22 (US60/957,383);
 2007/12/17 (US61/014,312)

(51) Cl.Int./Int.Cl. *A61M 16/00* (2006.01),
A61M 16/08 (2006.01)
 (72) Inventeurs/Inventors:
 FUHRMAN, BRADLEY P., US;
 DOWHY, MARK S., US
 (73) Propriétaire/Owner:
 THE RESEARCH FOUNDATION OF STATE
 UNIVERSITY OF NEW YORK, US
 (74) Agent: RIDOUT & MAYBEE LLP

(54) Titre : SYSTEME DE DISTRIBUTION ET DE PARTAGE DE GAZ RESPIRATOIRE ET PROCEDE
 (54) Title: BREATHING-GAS DELIVERY AND SHARING SYSTEM AND METHOD



(57) **Abrégé/Abstract:**

A device, system, and method for isolating a ventilator from one or more patients in which the delivery conditions of gas delivered to an isolation device from a ventilator may drive the delivery of breathing-gas delivered to one or more patients, the breathing-gas having the same or different delivery conditions. In one embodiment, an isolation device may have a housing and a movable partition. The movable partition may be joined to the housing, The movable partition may have a patient side on a first side of the partition and an actuating side on a second side of the partition. The isolation device may include an inlet pressure regulator on the actuating side and/or an exhaust pressure regulator on the patient side. These regulators may alter the delivery conditions (including, but not limited to, pressure and volume) of breathing-gas delivered to a patient.

Abstract

A device, system, and method for isolating a ventilator from one or more patients in which the delivery conditions of gas delivered to an isolation device from a ventilator may
5 drive the delivery of breathing-gas delivered to one or more patients, the breathing-gas having the same or different delivery conditions. In one embodiment, an isolation device may have a housing and a movable partition. The movable partition may be joined to the housing. The movable partition may have a patient side on a first side of the partition and an actuating side on a second side of the partition. The isolation device may include an inlet
10 pressure regulator on the actuating side and/or an exhaust pressure regulator on the patient side. These regulators may alter the delivery conditions (including, but not limited to, pressure and volume) of breathing-gas delivered to a patient.

BREATHING-GAS DELIVERY AND SHARING SYSTEM AND METHOD

Cross-Reference to Related Application

[0001] This application is a division of Canadian Patent Application No. 2,733,809
5 filed August 22, 2008 for “BREATHING-GAS DELIVERY AND SHARING SYSTEM
AND METHOD”.

[0002] This application claims the benefit of priority to U.S. provisional patent
application serial number 60/957,383, filed on August 22, 2007 and 61/014,312, filed on
December 17, 2007.

10 Field of the Invention

[0003] The present invention relates to patient ventilators. The present invention may
include one or more isolation devices associated with a patient ventilator, and these may be
used to provide breathing-gas to one or more patients.

Background of the Invention

15 [0004] The term “ventilator” is used herein to refer collectively to respirators and
ventilators, including various high frequency ventilators. In a hospital, patients may need the
assistance of a ventilator when they cannot breathe on their own. Ventilators are expensive
machines, and consequently hospitals tend not to have a large number of excess ventilators.
Pandemics are relatively infrequent, but potentially devastating mass casualty events. There
20 have been three influenza pandemics in the past century, and an estimated 32 in the past 400
years. In the event of a pandemic, such as that which might be caused by a mutant form of
Influenza H5N1, which is already endemic in wild birds and domestic fowl throughout Asia,
the number of patients that need ventilators may exceed the available supply. Estimates of
the magnitude of the shortage indicate that from 30% to 200% more ventilators will be
25 needed in a pandemic situation. During such a shortage, physicians may be faced with the
unpleasant decision of terminating the use of a ventilator by one patient so that another
patient may use it, or of withholding ventilator support from a new patient in need. In some
situations, terminating or failing to provide the use of a ventilator, even temporarily, will

result in a prolonged recovery time for a patient, harm to the patient, or even loss of the patient's life.

[0005] A single ventilator can be used to support several patients simultaneously, thereby increasing the number of patients who can be treated, but existing technology does not prevent cross contamination. That is to say that when patients share a ventilator using existing technology, the diseases, bacteria and viruses, carried by one patient may contaminate the environment and equipment used by another patient, and may be directly transmitted to the other patient. Furthermore, existing technology for sharing a ventilator severely limits the capacity to accommodate each individual patient's separate respiratory support needs because no mechanism is provided to separately accommodate each patient's respiratory needs, such as, for example, individualized tidal volume, peak pressure, oxygen concentration, and positive end-expiratory pressure ("PEEP").

[0006] There has been no prior description of the use of a re-breathing circuit to allow aseptic sharing of a ventilator among two or more patients. U.S. Pat. No. 6,675,799 (the "799 Patent") describes a re-breathing device that was intended to isolate a single patient from his/her ventilator, caregivers, and environment. However, the '799 Patent does not disclose how to ventilate more than one patient at the same time using a single ventilator. Nor does the '799 Patent address: (1) how to reduce patient tidal volume below the volume delivered to the device by a shared ventilator; (2) how to limit peak airway pressure below that set on the shared ventilator, (3) how to individualize oxygen concentration of patients sharing a ventilator; (4) how to increase PEEP above that set by a shared ventilator; or (5) how to conserve oxygen when several patients share a ventilator, all of which may be essential to the individualization of patient settings during shared ventilation. By way of contrast, an isolation device according to the present invention has the ability to alter the delivery conditions of breathing-gas and thereby individualize the characteristics of the breathing-gas patients receive using a ventilator that may be shared among several patients. This capability to alter the conditions under which breathing-gas may be provided to a patient using a disposable device, allows an inexpensive ventilator, having little sophistication, to deliver breathing-gas having better defined pressure, volume, and oxygen concentration characteristics to a patient.

[0007] Additionally, ventilators operate by using a supply of compressed gas to mechanically ventilate the lungs of a patient by increasing the pressure in the patient's airway. Typically, a ventilator requires both compressed air and compressed oxygen, in varying ratios depending on a patient's needs. Less-expensive ventilators, like those
5 stockpiled for pandemic preparedness, may not make efficient use of the gases supplied. This inefficiency is inconsequential with regard to compressed air because, in hospitals, mechanical compressors can be used to generate a continuous supply of pressurized air on-site, so shortages of compressed air are not anticipated, even during a pandemic. Compressed oxygen, however, is usually generated by gas suppliers located off-site and is generally
10 provided to hospitals as compressed oxygen in tanks, or as liquid oxygen. In a pandemic, shortages of both compressed and liquid oxygen are anticipated. Oxygen concentrators can be used to generate oxygen for spontaneously breathing patients, but cannot be used with most ventilators since most ventilators require a pressurized gas inflow at a pressure higher than can be generated by a typical oxygen concentrator. It would therefore be advantageous
15 to have a system, which reduces the amount of oxygen required for mechanical ventilation by using only compressed air to power lung inflation and an efficient re-breathing device to provide oxygen to the patient. No means has previously been described to conserve available oxygen when using less-expensive ventilators to cope with the expected shortage of pressurized oxygen or during a shortage of more advanced ventilators. The use of a re-
20 breathing device to conserve oxygen would help meet these needs.

[0008] During a mass casualty event, deploying disposable isolation devices to conserve oxygen and convert inexpensive, unsophisticated, oxygen-wasteful ventilators into affordable, yet more sophisticated, oxygen conserving, isolating ventilators, could save lives. This is not foreseen by the '799 Patent.

25 **Summary of the Invention**

[0009] The invention may be embodied as a device for isolating a ventilator from one or more patients. Such a device may have a housing and a movable partition. The movable partition may be joined to the housing and have a patient side of the partition and an actuating side of the partition. A ventilator may be connected to the housing on the actuating side of

the partition so that the ventilator is able to move the partition. The isolation device may include an inlet pressure regulator on the actuating side and/or an exhaust pressure regulator on the patient side. These regulators may alter the delivery conditions (including, but not limited to, pressure and volume) of breathing-gas delivered to a patient.

5 [0010] The invention may be embodied as a system which includes a ventilator and two or more isolation devices, which may be similar to that described above. Such a system may be used to provide breathing-gas to more than one patient using a ventilator. In a system of this embodiment, inlet pressure regulators and/or exhaust pressure regulators may be used to individualize delivery conditions of the breathing-gas delivered to each patient according
10 to his or her needs.

[0011] The invention may be embodied as a method for using a ventilator to provide breathing-gas to at least two patients by way of a ventilator and at least two isolation devices. The isolation devices may be similar to those described above, and may include inlet and/or exhaust pressure regulators to individualize the delivery conditions of the breathing-gas
15 delivered to each patient according to his or her needs.

[0012] The invention may be embodied as a method for enhancing the performance of a ventilator. A method of this embodiment may use a ventilator and an isolation device similar to that described above, which includes an inlet pressure regulator and/or an exhaust pressure regulator to modify the delivery conditions of breathing-gas delivered to a patient.

20 **Brief Description of the Drawings**

[0013] For a fuller understanding of the nature and objects of the invention, reference should be made to the accompanying drawings and the subsequent description. Briefly, the drawings are:

Figure 1 is a diagram of a device according the invention;
25 Figure 2 is a schematic of a system according to an embodiment of the invention;

Figure 3 is a schematic showing a system according to another embodiment of the invention;

Figure 4 is a schematic showing details of the embodiment of Figure 2;

Figure 5 is a diagram of one type of inlet pressure regulator;

5 Figure 6 is a diagram, showing pressure measuring points, of a device according to an embodiment of the invention;

Figure 7A is a diagram of a Starling resistor shown in a closed (occluded) configuration;

10 Figure 7B is a diagram of a Starling resistor shown in an open configuration;

Figure 8 is a diagram of a device having a pneumotachometer according to another embodiment of the invention;

Figure 9 is a diagram of a device using a bellows according to another embodiment of the invention;

15 Figure 10 is a detail of the ventilation path and part of the housing in another embodiment of the invention showing an alternative location for a PEEP valve;

Figure 11 is a flowchart showing a method according to the invention; and

20 Figure 12 is a flowchart showing a method according to another embodiment of the invention.

Further Description of the Invention

[0014] The invention may be embodied as a device for isolating a ventilator from one or more patients. Figure 1 shows an isolation device **10** according to the present invention.
25 The isolation device **10** may have a housing **13** disposed about a movable partition **16**. The movable partition **16** may be joined to the housing **13** and have a patient side **22** of the movable partition **16** and an actuating side **25** of the movable partition **16**. The movable partition **16** may be in the form of a flexible bag. The isolation device **10** may include an inlet pressure regulator **82** in fluid communication with the actuating side **25**. The inlet
30 pressure regulator **82** may regulate the pressure of breathing-gas allowed on the actuating

side **25**. The inlet pressure regulator **82** may also limit the pressure on the actuating side **25** to a desired maximum (“peak pressure”). The isolation device **10** may include an exhaust pressure regulator **84** in fluid communication with the patient side **22** of the movable partition **16**. The exhaust pressure regulator **84** may regulate a pressure in the housing **13** on the patient side **22** during exhalation and may be used to generate a PEEP on the patient side **22** that differs from that of a ventilator by, for example, restricting the outflow of gas from the housing **13** on the patient side **22**, thus maintaining a higher end-expiratory pressure than may be set on a ventilator.

[0015] The housing **13** also may have a ventilator orifice **28** in fluid communication with the actuating side **25** that is adaptable to be in pneumatic communication with a ventilator **29**. The housing **13** also may have a patient inspiration orifice **31** in fluid communication with the patient side **22** that is adaptable to be in pneumatic communication with a patient. The housing **13** may have a bias inflow orifice **33** in fluid communication with the patient side **22** that is adaptable to be in pneumatic communication with a source of fresh inspiratory gas **80**. The housing **13** may have an expiration return orifice **36** in fluid communication with the patient side **22**. The isolation device **10** may also include a CO₂ scrubber **55** in fluid communication with the patient side **22** to reduce the level of CO₂ in the gas that returns to the patient during re-breathing. Such a scrubber **55** may be located so that breathing-gas from the housing **13** flows through the scrubber **55** to the patient on inspiration, and/or so that breathing-gas from the patient flows through the scrubber **55** to the housing **13** on expiration. Figure 4 depicts a scrubber **55** connected to “Patient 1” by way of an exhalation line **96** and another scrubber **55** connected to “Patient 2” by way of an inhalation line **98**.

[0016] Figure 2 shows that the invention may be embodied also as a breathing-gas sharing system **15**. In such a system **15**, a ventilator **29** and at least two isolation devices **12** are provided. The ventilator **29** may be connected to an inlet **16** of each of the isolation devices **12** by way of ventilation path **42**. The isolation devices **12** may be of many types known in the art, for example, the type disclosed in the ‘799 patent, or the type described above. Figure 3 schematically depicts another embodiment of a breathing-gas sharing system

17 in which four isolation devices **12** are shown. One patient could be associated with each isolation device **12**.

[0017] Figure 4 depicts a breathing-gas delivery system **20** according to another embodiment of the invention. The system **20** of this figure is shown with two patients being ventilated by a single ventilator **29**, and using two isolation devices **40** that function like that described above. Each housing **13** may be made of more than one piece, for example, the portion of the housing **13** on the patient side **22** may be one piece and the portion on the actuating side **25** may be another piece. The portion of the housing **13** on the patient side **22** may receive fresh gas from a fresh gas source **80**. The fresh gas flow may be controlled by a fresh gas controller **78** and the fresh gas may be altered by a conditioner **99**. The conditioner **99** may be, for example, a vaporizer, a nebulizer, a blender, a mixer, a humidifier, or any combination of these devices. Figure 4 shows that patients may be connected to re-breathing circuits, and that the re-breathing circuits may include check valves **66**, **63** and a CO₂ scrubber **55**.

[0018] In operation, the ventilator **29** may be set to provide either: (1) a peak pressure and a desired end-expiratory pressure (the “pressure-mode”); or (2) a desired tidal volume and end-expiratory pressure (the “volume-mode”). In pressure-mode operation, the isolation device **40** may be provided with the peak pressure and the end-expiratory pressure of the ventilator **29**, and a patient will get a tidal volume determined by their chest compliance. If more than one isolation device **40** (and therefore more than one patient) is connected to the ventilator **29** in pressure-mode, then any particular patient will receive a tidal volume determined by that patient’s chest compliance. However, in such a case, the tidal volume delivered to a patient may not be appropriate for that patient; for example, the peak pressure may cause a tidal volume that is too low for a particular patient, thus not delivering enough oxygen to, or removing enough carbon dioxide from, that patient. In order to avoid that situation, the peak pressure may be selected so as to adequately ventilate the stiffest lung among those that are being ventilated, provided that the peak pressure does not exceed some safe upper limit (e.g. 35 to 50 cm of water).

[0019] The peak pressure delivered to a particular isolation device **10** may be reduced below the ventilator **29** peak pressure using an inlet pressure regulator **82** (Figure 1), which may partially or completely occlude the ventilation path **42**, which connects the ventilator **29** to the isolation device **10**. Figure 5 depicts one such inlet pressure regulator **82** that uses a ventilator path occlusion caliper **86** to work against a flexible tube **88**. An adjustable signal may be provided to the inlet pressure regulator **82** by, for example, a pressure transducer **87**. Re-opening of this inlet pressure regulator **82** may be initiated by a subsequent signal, in response to, for instance, a fall in ventilator **29** pressure below that of the isolation device **10**, which may be measured by, for example, a downstream pressure transducer **45**. Such a fall in ventilator **29** pressure (below that of the isolation device **40**) may occur at the onset of a pre-set ventilator **29** expiratory cycle if the inlet pressure regulator **82** has closed the tube **88**.

[0020] In a system **20** of the present invention, the ventilator **29** may serve as a timing device to set the respiratory cycle and power the mechanical ventilation of the lungs of one or more patients via the isolation device(s) **40**. For this reason, the ventilator **29** need not be an expensive, advanced device since the isolation device **40** may control patient-specific parameters such as, for example, patient tidal volume, peak airway pressure, and PEEP. Therefore, it should be understood that the ventilator **29** may be, among other things, a mechanical ventilator, a manual ventilator such as an ambu bag, or a continuous positive airway pressure (“CPAP”) device which merely delivers constant positive airway pressure.

[0021] Ventilators **29**, especially less expensive models, may use large volumes of gas to perform the ventilation function. Further, these devices may be “leaky” in that some of the gas provided to the ventilator may be lost due to leaks or other inefficiencies and therefore, not fully delivered to the patient. When ventilators are supplied with gas supplemented by oxygen, the leaks may cause an inefficient use of this supplemental oxygen—a resource which may be in short supply. In a system **20** of the present invention, the ventilator **29** may use room air from a compressor to move the partition **16** in the isolation device(s) **40**. This may alleviate the need to supply the potentially inefficient ventilator **29** with both pressurized air and pressurized oxygen as would be required when using a ventilator **29** to directly ventilate a patient without the use of isolation device(s) **40**. When using pressurized air in the ventilator **29** to move partition **16** in the isolation device(s) **40**,

each patient's oxygen needs may be met by providing supplemental oxygen directly to each isolation device **40** where the oxygen may be more efficiently used. The fresh gas source **80** may include a system to supply oxygen from a liquid oxygen tank, compressed gas cylinder, or oxygen concentrator. Fresh gas flow rates may be selected independently for each
5 isolation device **40**. The fresh gas flow rates may be selected to complete filling of the lungs to an optimal peak pressure with the ventilator path occlusion caliper **86** closed. In order to do so, the occlusion caliper **86** may remain open while the ventilator **29** may be used to deliver inhalation gas to the patient, and when the ventilator **29** has reached a predetermined pressure, for example its peak pressure, the occlusion caliper **86** may be closed and fresh gas
10 flow may, then, be used to augment tidal volume above that propelled by the ventilator **29**.

[0022] A conditioner **99**, may be, for example, a blender to mix oxygen and air to individualize oxygen concentration of the gas supplied to the portion of the isolation device **40** on the patient side **22**. A re-breathing circuit may be employed to more completely utilize the fresh gas entering the portion of the isolation device **40** on the patient side **22**. Using a re-
15 breathing circuit, the system **20** may use low fresh gas flow rates, and that may reduce the use of oxygen to a fraction of what would otherwise be required.

[0023] To control the end-expiratory pressure, the signal to the inlet pressure regulator **82** may also be used to control an exhaust pressure regulator **84** (see Figures 1 and 6) to occlude a gas exhaust line **72** (see Figures 1 and 2) and to prevent exhausting gas from
20 the portion of the isolation device **10, 40** on the patient side **22** during inspiration. Alternatively, a Starling resistor may be used to regulate the release of gas from the portion of the isolation device **10, 40** on the patient side **22** and such a Starling resistor may be connected such that pressure within the isolation device **10, 40** must exceed the pressure in the ventilator circuit in order for exhaust to leave the portion of the isolation device **10, 40** on
25 the patient side **22**. Figures 7A and 7B depict such a Starling resistor **46**—in the closed and open configuration, respectively—wherein a gas flow from a resistor inlet **47** to a resistor outlet **48** is controlled by the pressure in a control line **49**. In use, the resistor inlet **47** of the Starling resistor **46** may be connected to the portion of the isolation device **10, 40** on the patient side **22**, the resistor outlet **48** may be connected to the gas exhaust line **72**, and the
30 control line **49** may be connected to the ventilator path **42**, between the housing **13** and the

inlet pressure regulator **82**. A manually adjustable PEEP valve **89**, located either before or after the Starling resistor or caliper, may then be used to up-regulate PEEP above that set on the ventilator **29** when it is necessary to modify the patient's PEEP to exceed that set by the ventilator **29**. This may have the additional benefit of promoting the emptying of the portion of the isolation device **10, 40** on the actuating side **25** before the next inhalation, assuring consistency of delivered tidal volume. In an alternative embodiment shown in Figure 10, the PEEP valve may be located in the ventilator path **42**.

[0024] In the embodiment shown in Figure 6, a particular pressure difference between the pressure (**P3**) on the patient side **22** of the partition **16** and the pressure (**P2**) on the actuating side **25** of the partition **16** may be measured and a threshold value may then be used to trigger events that reduce gas inflow from a ventilator **29** to the isolation device **50** by occluding the ventilator path **42**, thereby setting the tidal volume and end-inspiratory pressure of the patient. Such a pressure difference may be caused, for example, by a position biaser such as, for example, a tether **34** having two ends, wherein a first one of the ends is connected to the movable partition **16** and a second one of the ends is connected to the housing **13**. In addition to creating a pressure difference across the partition, the position biaser may create a restoring force to return the movable partition **16** toward its resting shape and position. In another example, the pressure difference across the movable partition **16**, and the restoring force may be generated by an elastic property of the movable partition **16** or its attachments, for example if the movable partition **16** is made from a material comprising an elastic material such as, for example, latex. The pressure difference across the movable partition **16** may be used to control the fresh gas controller **78** or the inlet pressure regulator **82**. The pressure difference generated by such a restoring force is generally proportionate to the degree of displacement of the movable partition **16** and is therefore a suitable indicator of tidal volume. A subsequent pressure drop in the ventilator **29** (**P1**) that accompanies the onset of a ventilator outflow cycle would create a pressure difference across the inlet pressure regulator **82** which may be used to signal reopening of the inlet pressure regulator **82**.

[0025] Air leaks may occur in the patient or may occur in the airway connections, for example, around an endotracheal tube. Pressure **P3** on the patient side **22**, while the ventilation path **42** is occluded, may be used to detect and respond to air leaks on the patient

side **22** or around the patient connection. When using a re-breathing circuit, air leaks may create a need for compensatory fresh gas flow to prevent loss of pressure on the patient side **22**. The pressure **P3** on the patient side **22** may be sensed and compared to a desired value. When the pressure **P3** is less than the desired value while the ventilation path **42** is occluded, an air leak may be indicated and fresh gas flow may be increased by signaling the fresh gas inflow controller **78**. This mechanism creates a new mode of mechanical ventilation, which might best be termed “leak compensated, pressure regulated, volume controlled.”

[0026] The pressure **P3** of the patient side **22** of the partition **16** may be sensed and compared to the pressure **P1** of the ventilator **29** to control the timing of occlusion and reopening of the exhaust pathway by way of the exhaust pressure regulator **84**, which may comprise, for example a Starling resistor. For example, if the exhaust pressure regulator **84** is in an occluded state, and a transition is measured wherein pressure **P3** becomes greater than the pressure **P1** after being less than or equal to pressure **P1**, then a ventilator expiratory cycle may be indicated and an activation signal may be sent to the exhaust pressure regulator **84** to cause the exhaust pressure regulator **84** to open.

[0027] Other functions, including fresh gas inflow and/or ventilator disconnect alarms, may be triggered by pressures **P1**, **P2**, and **P3** or by the relations of these pressures to one-another. For example, if the pressure of any of **P1**, **P2**, or **P3** were to remain at 0 psig during a period when the pressure should be above or below 0 psig, then an alarm may sound to indicate that the ventilator may be disconnected or shut off. When using a position biaser **34**, a strain gauge may be used to trigger these functions based on tension in a tether of the position biaser **34**, rather than on pressure differences. Figure 10 depicts a ventilation path **42** and housing **13** showing one example of where pressure transducers **87**, **43**, **41** may be located to measure **P1**, **P3**, and the difference between **P2** and **P3**, respectively.

[0028] Figure 8 depicts an isolation device **90** of the present invention having a pneumotachometer **85**. The pneumotachometer **85** may be in pneumatic communication with the actuating side **25** and may be connected between the inlet pressure regulator **82** and the ventilator **29**. In such an embodiment, the pneumotachometer **85** may measure the tidal volume during inspiration and the pneumotachometer **85** may cause the inlet pressure

regulator **82** to occlude the “path” when a desired tidal volume has been delivered. A controller circuit **44** may be connected to the pneumotachometer **85** and the inlet pressure regulator **82** in order to use a signal from the pneumotachometer **85** to control the regulation of the inlet pressure regulator **82**. Pneumotachometers **85** might also be placed between the patient inspiratory orifice **31** and the patient side **22**, or between the patient and the CO₂ scrubber **55**, in the patient exhalation line. Such pneumotachometers **85** may be used to measure patient inspiratory and expiratory tidal volumes. The difference in tidal volume on inspiration and expiration may indicate leaks in the system and/or may be used to control the fresh gas controller **78** to adjust the inflow of fresh gas.

10 [0029] In Figure 9, yet another embodiment of the invention is depicted. In the isolation device **30** of this embodiment, the movable partition **16** is shown as a diaphragm **23** and a bellows **24**. A position indicator **26**, which may be disposed on the diaphragm **23**, may be used to generate the triggering signals for opening or closing the inlet pressure regulator **82**, the exhaust pressure regulator **84**, the fresh gas controller **78** for fresh gas inflow, and/or ventilator disconnect alarms. The position indicator **26** may be a strain gauge mounted on the tether or between the movable partition **16** and housing **13**. Alternatively, Figure 9 shows that the position indicator **26** may be an optical or magnetic instrument, which has an emitter **92** attached to the movable partition **16** and a receiver **94** capable of detecting the location of the emitter **92**.

20 [0030] The invention may also be embodied as a method for sharing a single ventilator between at least two patients. Figure 11 depicts one such method. A method according to the invention may comprise the steps of providing **100** a ventilator, providing **110** a first isolation device, providing **120** a second isolation device, utilizing **130** the ventilator to drive a respiratory cycle in each of the first and second isolation devices, and utilizing **140** the first isolation device to provide mechanical ventilation of the lungs of a first patient and the second isolation device to provide mechanical ventilation of the lungs of a second patient. The first and second isolation devices may be of many types known in the art, for example, the type disclosed in the ‘799 patent, or the type described above. The first and second isolation devices each may or may not be equipped with an inlet pressure regulator and/or and exhaust pressure regulator. The inlet and/or exhaust pressure regulators

25
30

may be used to modify the delivery conditions, for example, pressure and volume, of gas delivered to patients' lungs for mechanical ventilation, from the conditions of gas delivered from the ventilator to drive the respiratory cycle.

[0031] Figure 12 depicts a method for altering the performance characteristics of a ventilator that is in keeping with an embodiment of the invention. A method according to the invention may comprise the steps of providing **200** a ventilator, providing **210** an isolation device that includes an inlet pressure regulator and an exhaust pressure regulator, utilizing **220** the ventilator to drive the isolation device, utilizing **230** the isolation device to provide mechanical ventilation of the lungs of a patient. The inlet pressure regulator and/or the exhaust pressure regulator may modify the delivery conditions, for example, pressure and volume, of gas delivered to the patient's lungs for mechanical ventilation, from the properties of gas delivered from the ventilator to drive the respiratory cycle.

[0032] It will now be recognized that the invention provides a system and method by which a single ventilator may be used to aseptically ventilate one or more patients. Further, it will be recognized that less-expensive ventilators may be used to ventilate one or more patients by providing isolation devices which can individually regulate tidal volume, oxygen fraction, and PEEP. The system is also able to isolate the ventilator from an infected patient, and to reduce the hazard of contagion for respiratory therapists who clean and re-deploy ventilators. This system also may allow for reduction of the amount of oxygen used, which may be helpful when oxygen is in short supply, for example during a mass casualty event.

[0033] Although the present invention has been described with respect to one or more particular embodiments, it will be understood that other embodiments of the present invention may be made without departing from the scope of the present invention.

What is claimed is:

1. A patient respiration isolation device, comprising:
 - 5 a movable partition having an actuating side on a first side of the movable partition,
and a patient side on a second side of the movable partition;
 - a housing disposed about the movable partition, the housing having an ventilator
orifice adaptable to be in pneumatic communication with a ventilator;
 - an inlet pressure regulator in fluid communication with the actuating side of the
movable partition; and
 - 10 an exhaust pressure regulator capable of controlling a positive-end-of-expiration
pressure (“PEEP”) in fluid communication with the patient side of the movable
partition.
2. The isolation device of claim 1, further comprising a CO2 scrubber in fluid communication
15 with the patient side of the movable partition.
3. The isolation device of claim 1, wherein the movable partition is a flexible bag.
4. The isolation device of claim 1, wherein the movable partition is comprised of an elastic
20 material.
5. The isolation device of claim 1, wherein the movable partition comprises a bellows and a
diaphragm.
- 25 6. The isolation device of claim 1, further comprising a position sensor capable of detecting a
position of the movable partition.
7. The isolation device of claim 1, wherein the housing includes a fresh gas orifice for
providing fresh gas from a fresh gas source, and wherein the fresh gas orifice is in fluid
30 communication with the patient side of the movable partition.

8. The isolation device of claim 1, further comprising an exhaust line extending from the housing, wherein the exhaust line is in fluid communication with the patient side of the movable partition.
- 5 9. The isolation device of claim 1, wherein the inlet pressure regulator comprises a flexible tube and a caliper.
10. The isolation device of claim 1, wherein the exhaust pressure regulator comprises a flexible tube and a caliper.
- 10 11. The isolation device of claim 1, wherein the exhaust pressure regulator comprises a Starling resistor.
12. The isolation device of claim 1, further comprising a tether having a first end and a second end, wherein the first end is connected to the movable partition and the second end is connected to the housing.
- 15 13. The isolation device of claim 1, further comprising a pneumotachometer connected to the ventilator orifice and capable of measuring a gas volume of gas flowing into and/or out of the housing.
- 20 14. The isolation device of claim 1, wherein the housing further comprises a patient orifice in fluid communication with the patient side of the movable partition and the patient orifice is adaptable to be in fluid communication with a patient.
- 25 15. The isolation device of claim 14, further comprising a pneumotachometer connected to the patient orifice and capable of measuring a gas volume of gas flowing into and/or out of the housing.
- 30 16. Use of a patient respiration isolation device of any one of claims 1-15 for enhancing the performance of a ventilator.

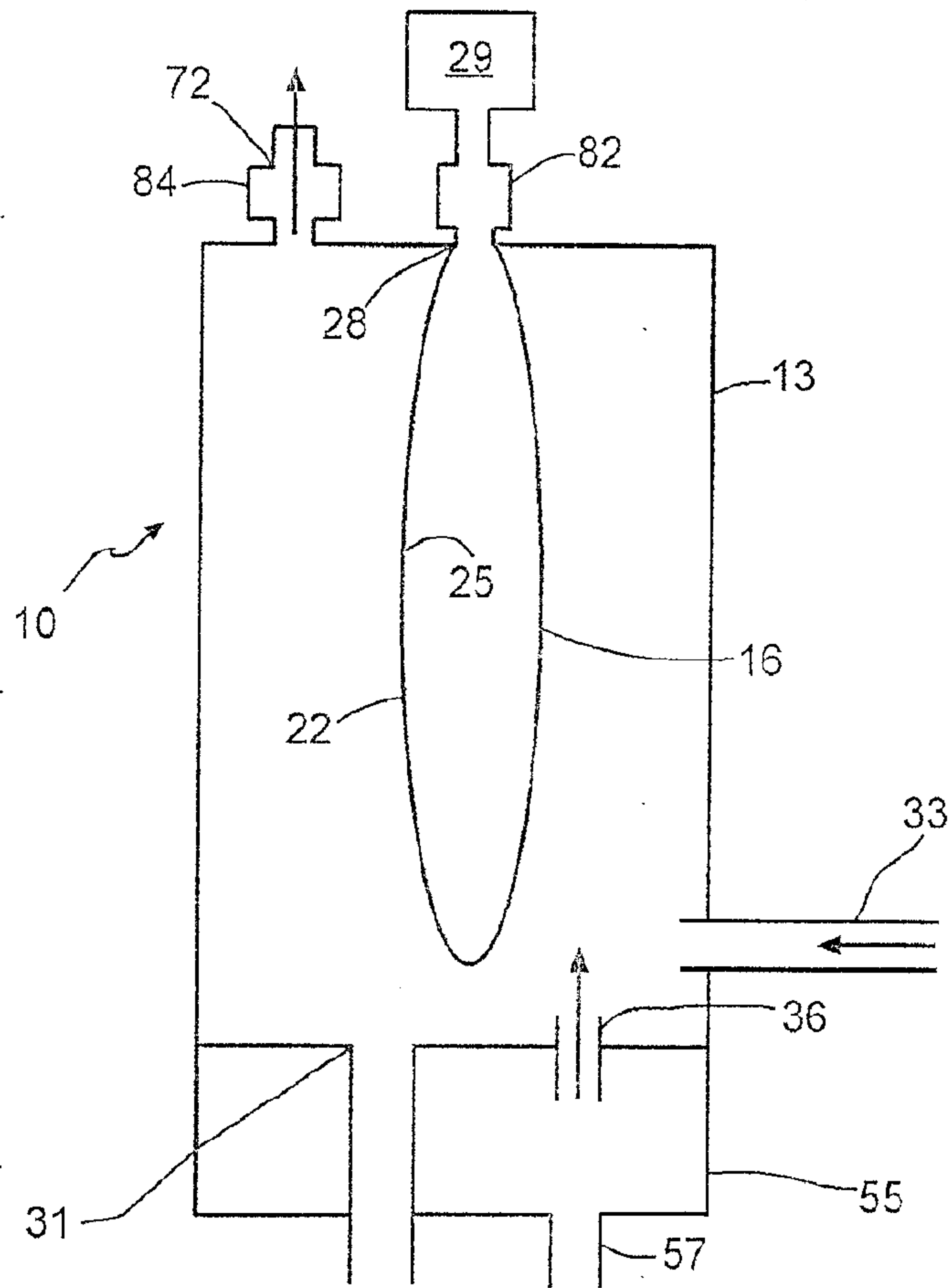

FIG. 1

2 / 12

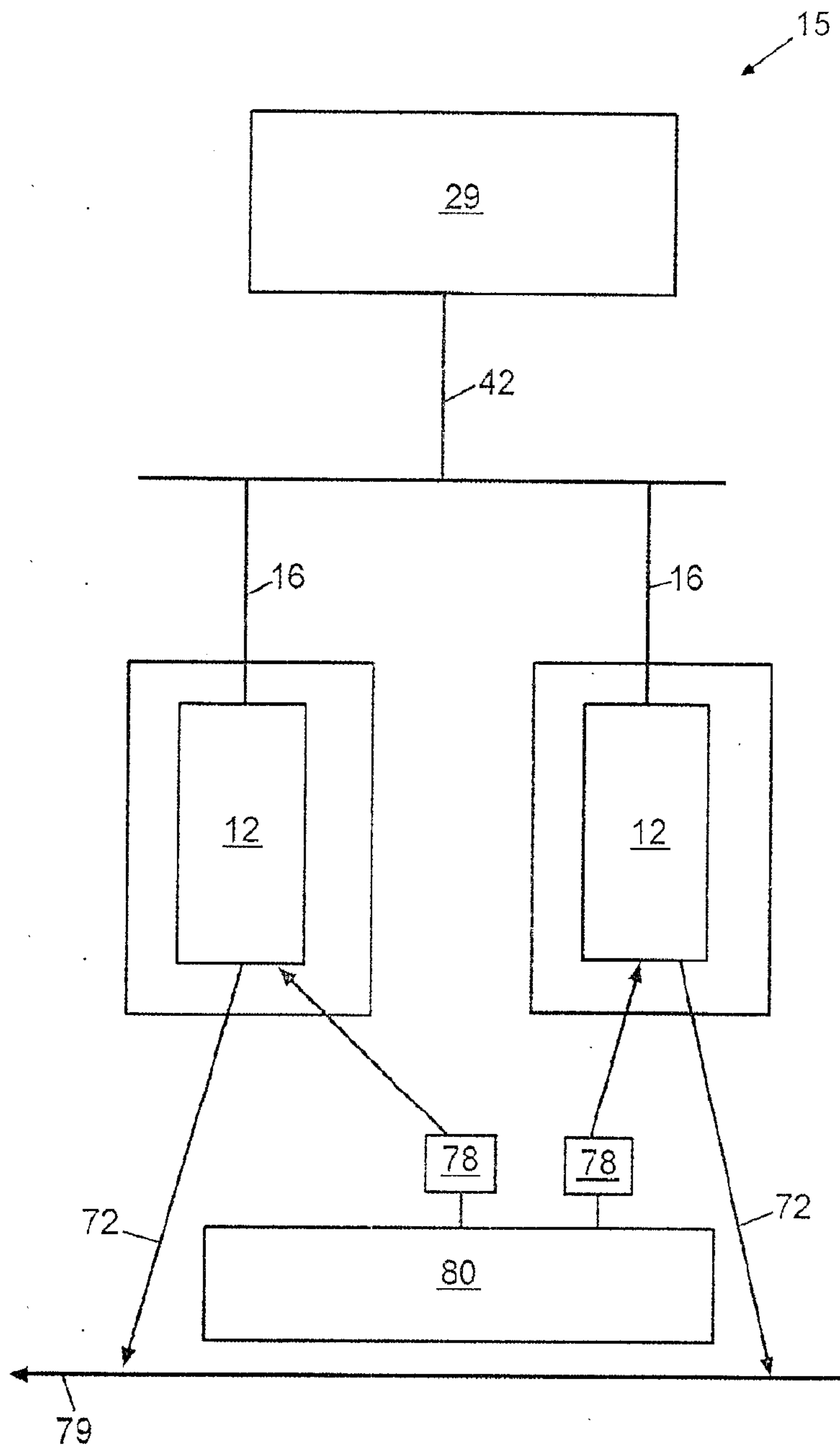
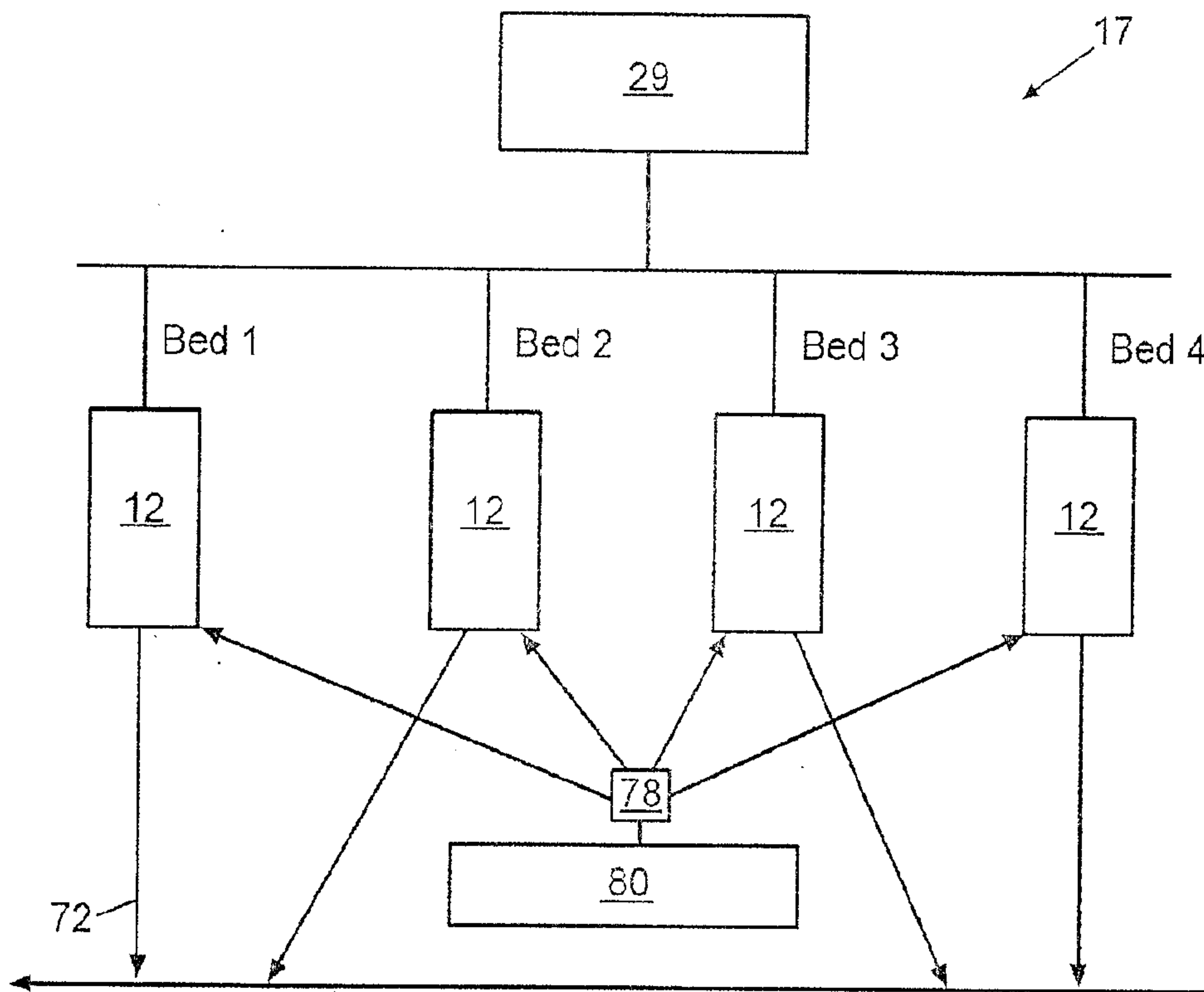
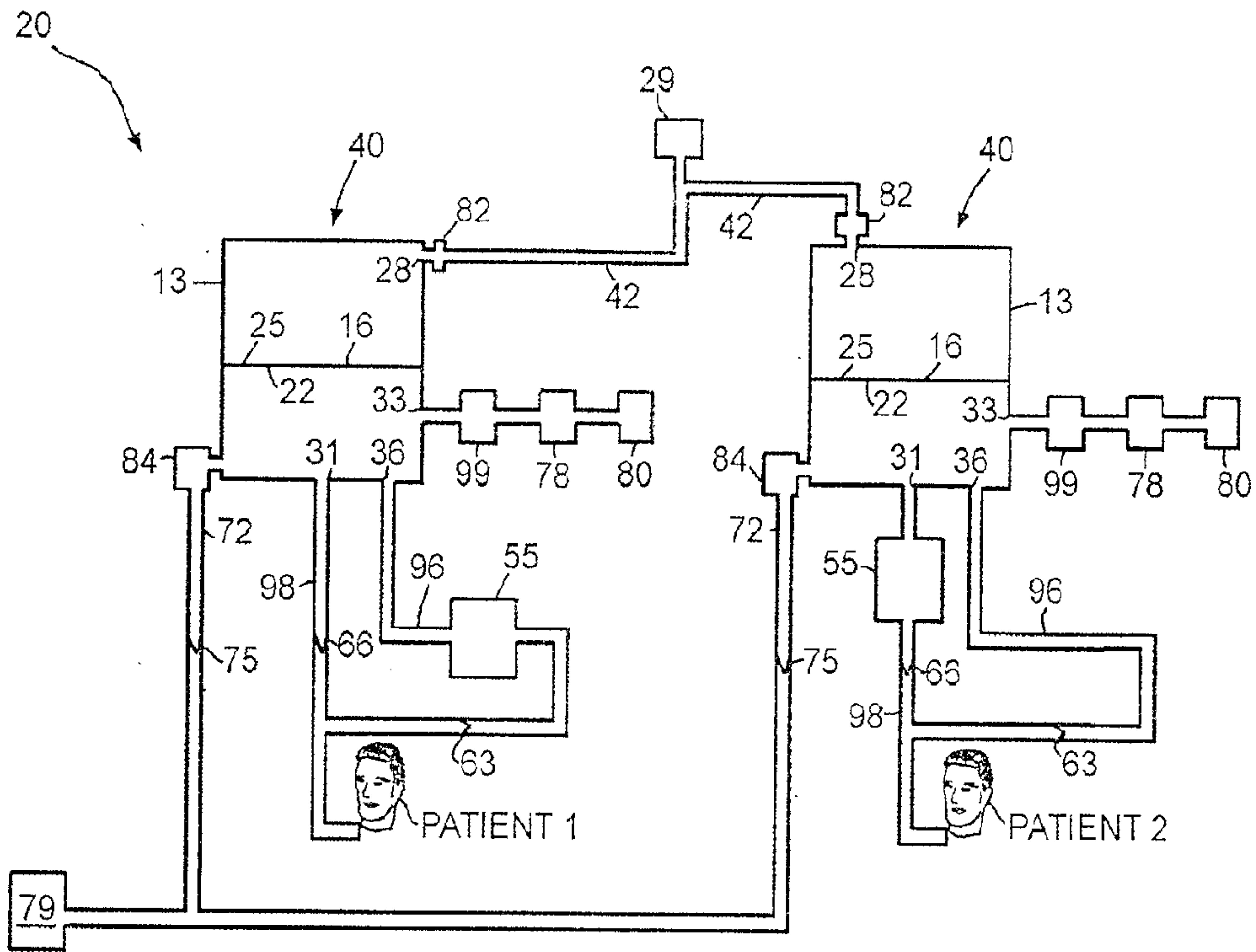

FIG. 2

3 / 12



—FIG. 3



—FIG. 4

5 / 12

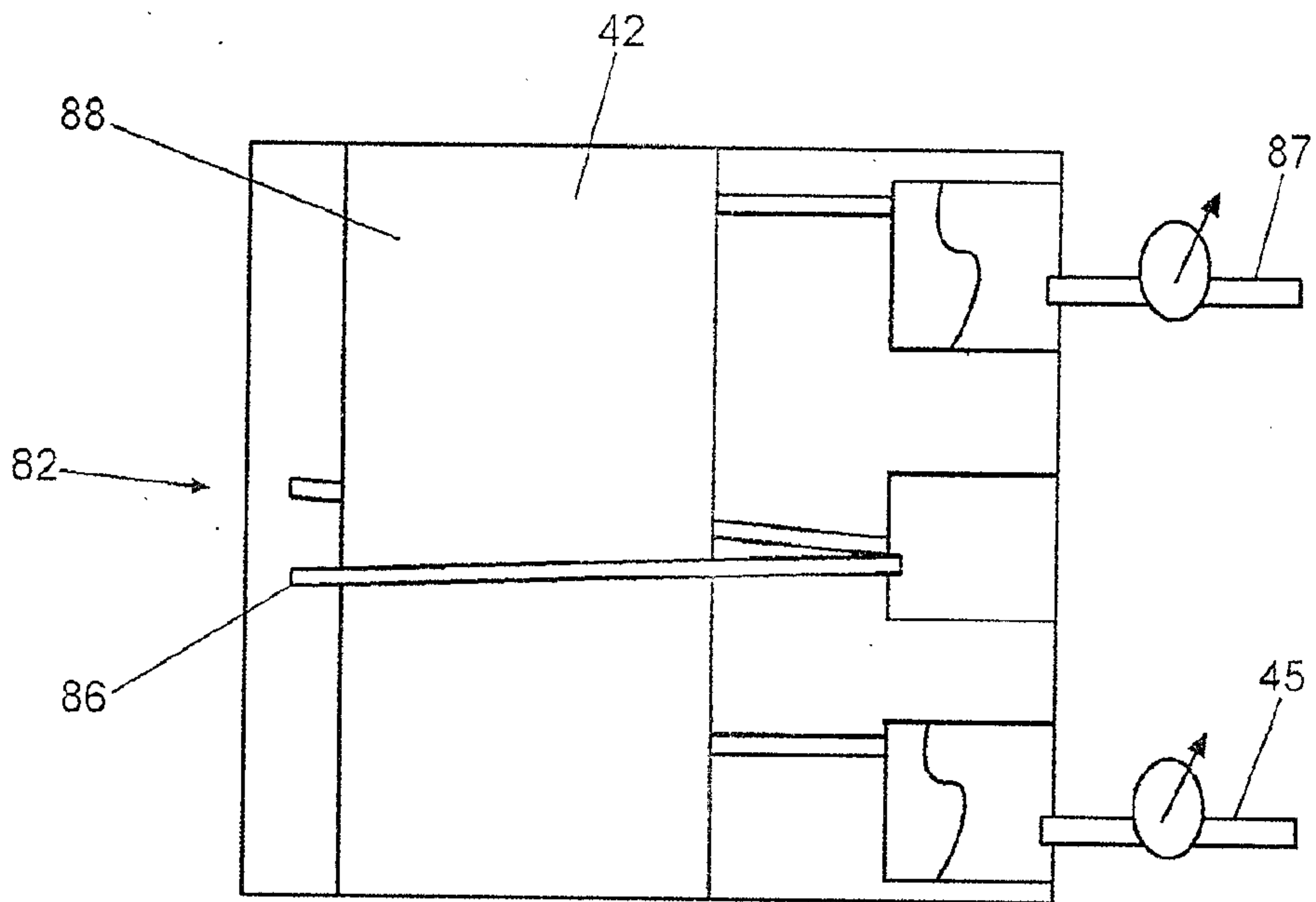

—FIG. 5

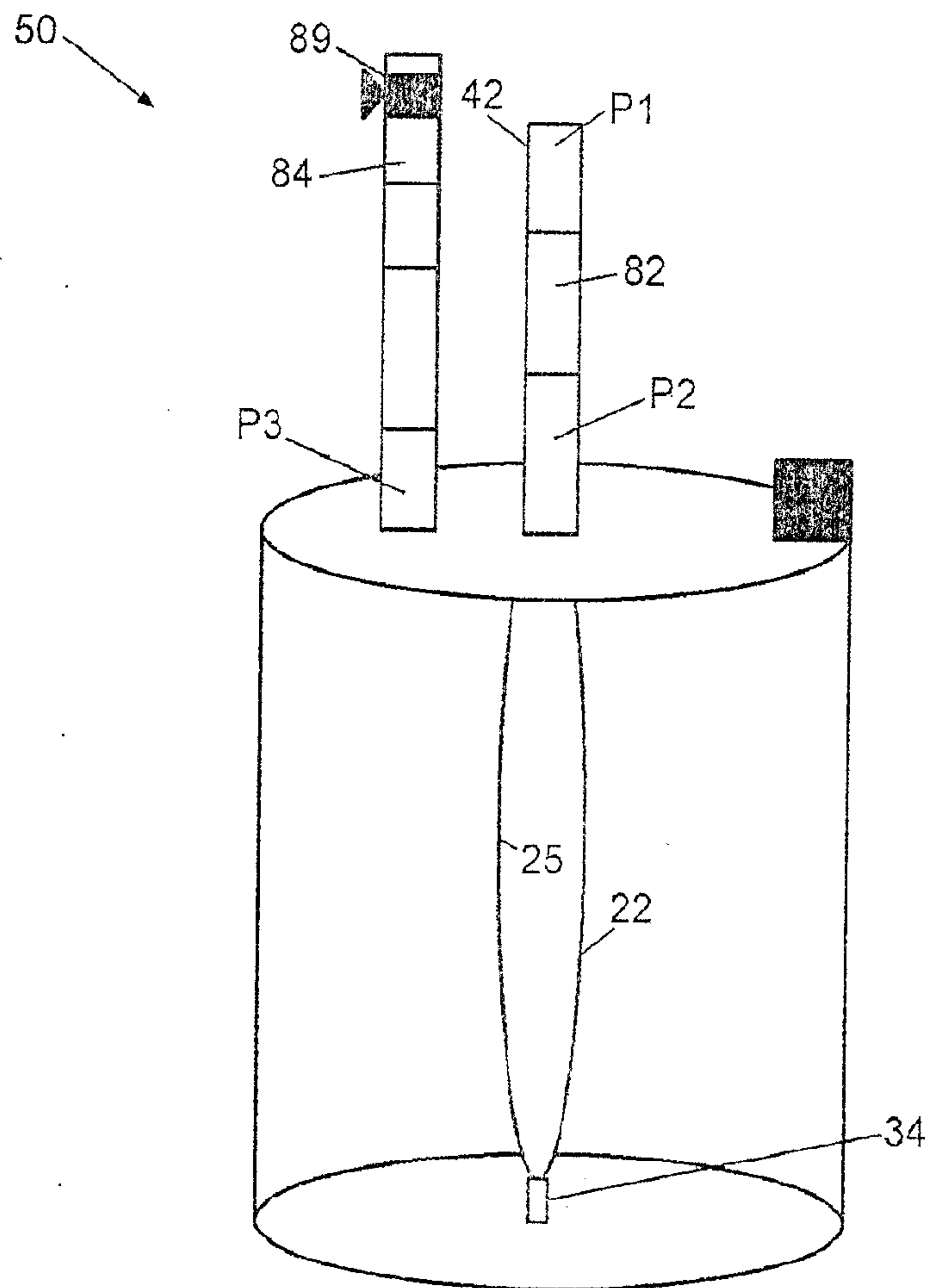

FIG. 6

7 / 12

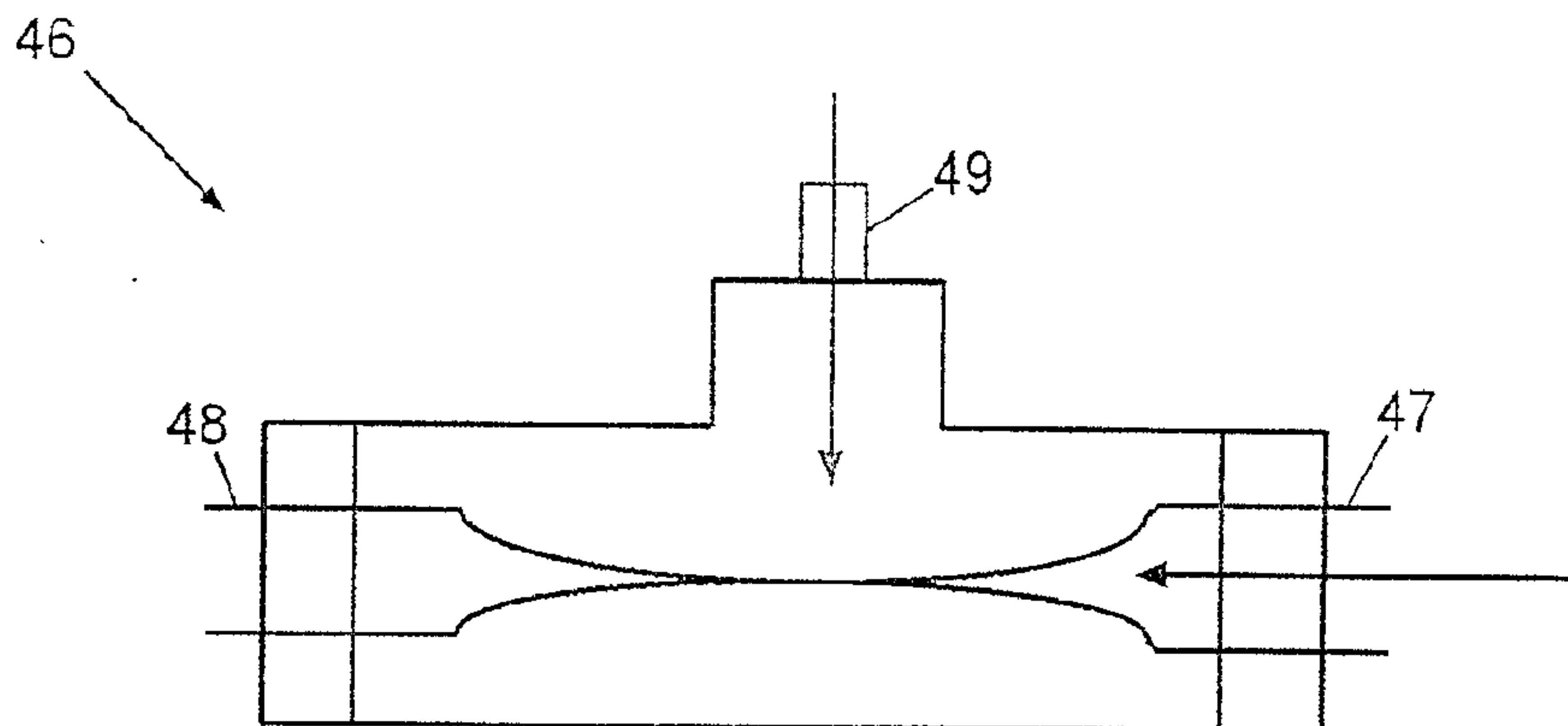

FIG. 7A

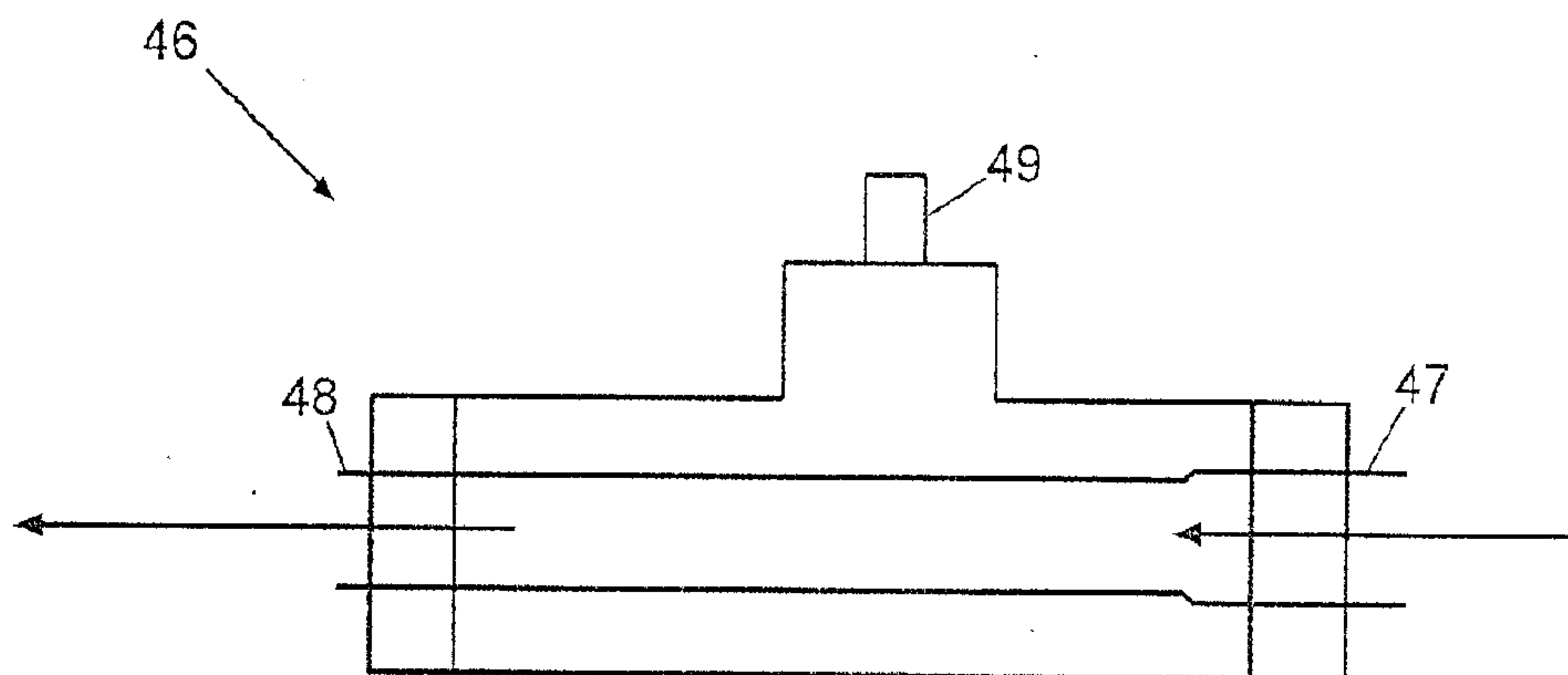

FIG. 7B

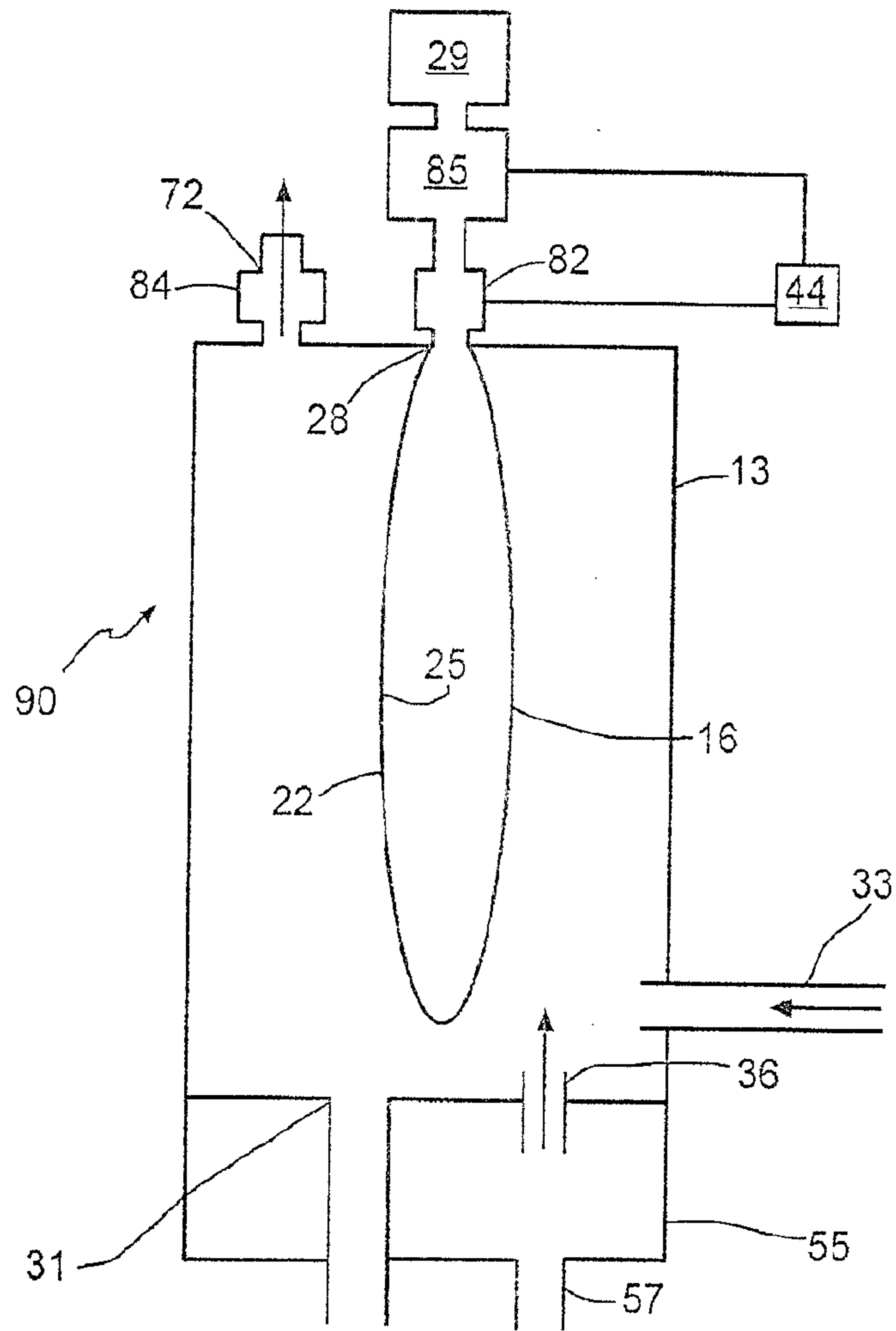

FIG. 8

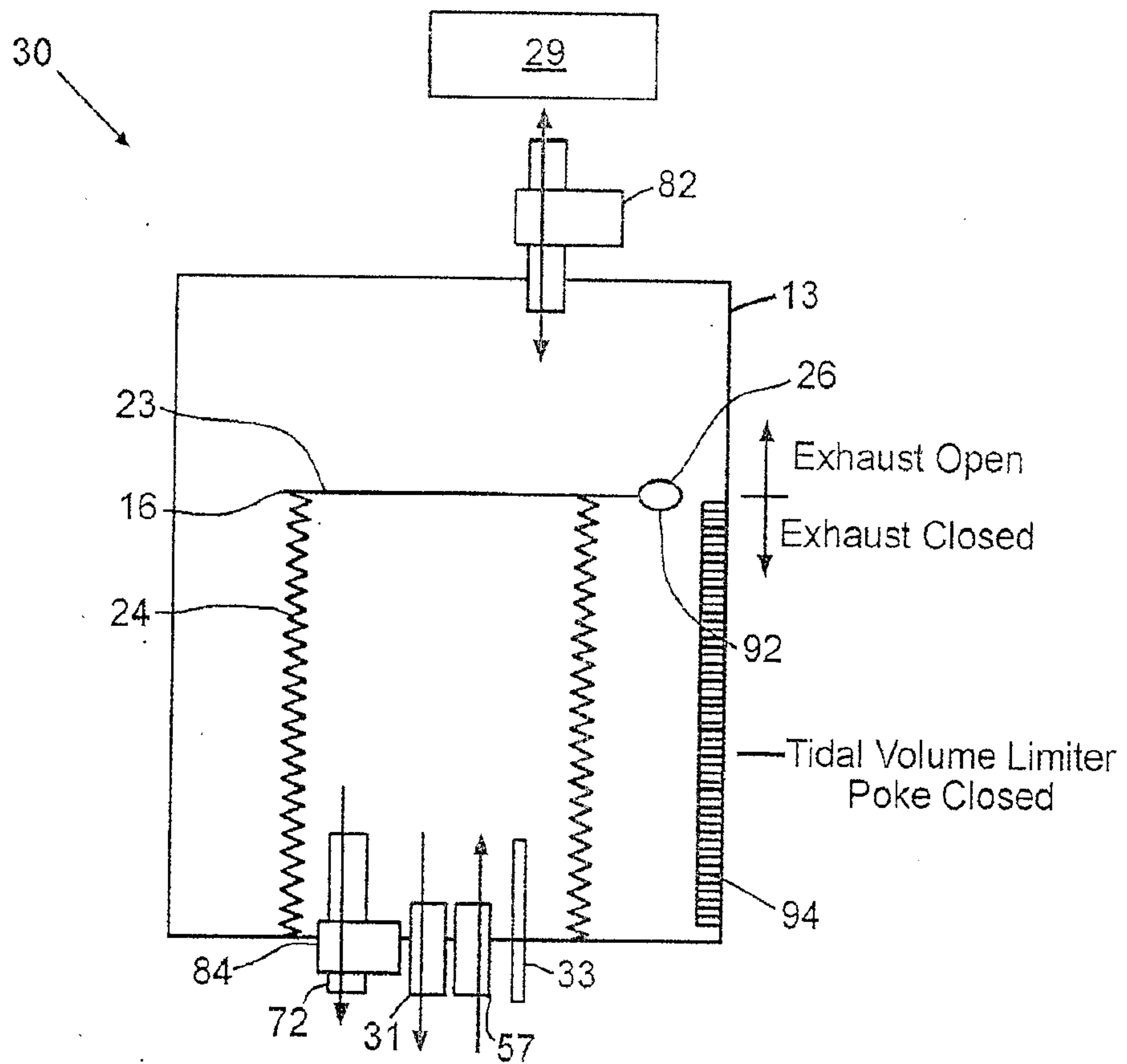

FIG. 9

10 / 12

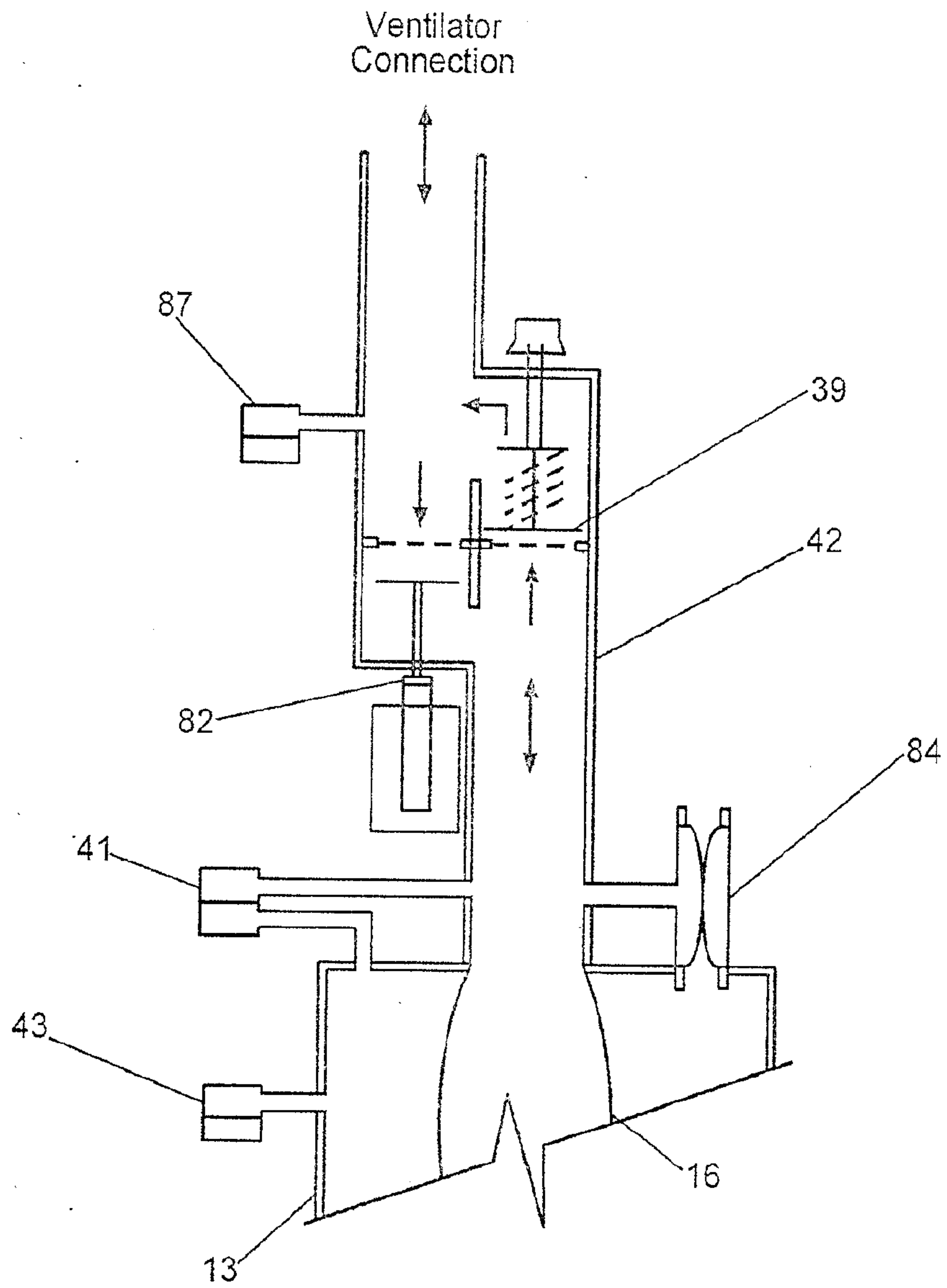

FIG. 10

11 / 12

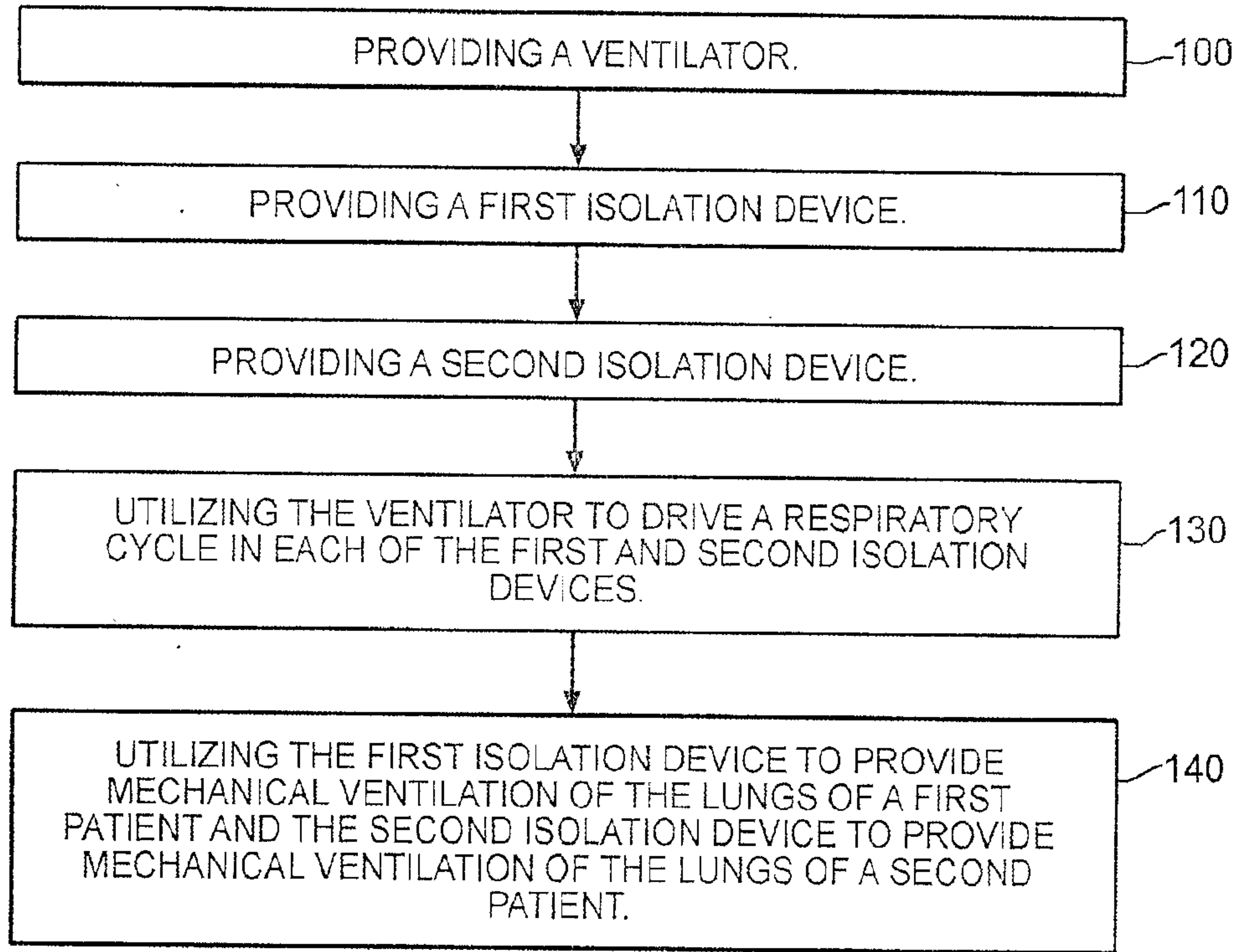

FIG. 11

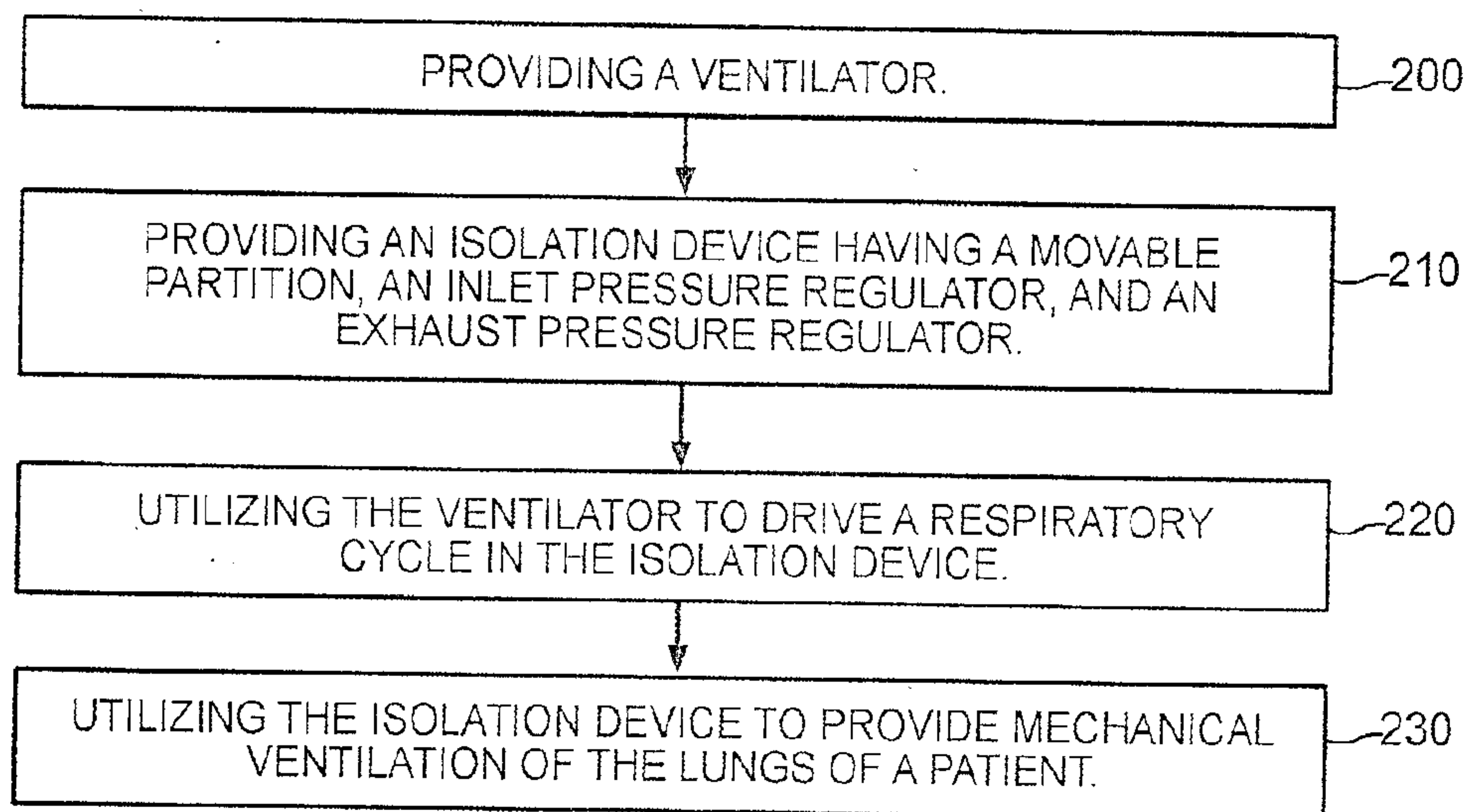

FIG. 12

