

Oct. 22, 1935.

H. A. BARNBY

2,018,004

CONTAINER AND CLOSURE THEREFOR

Filed April 12, 1933

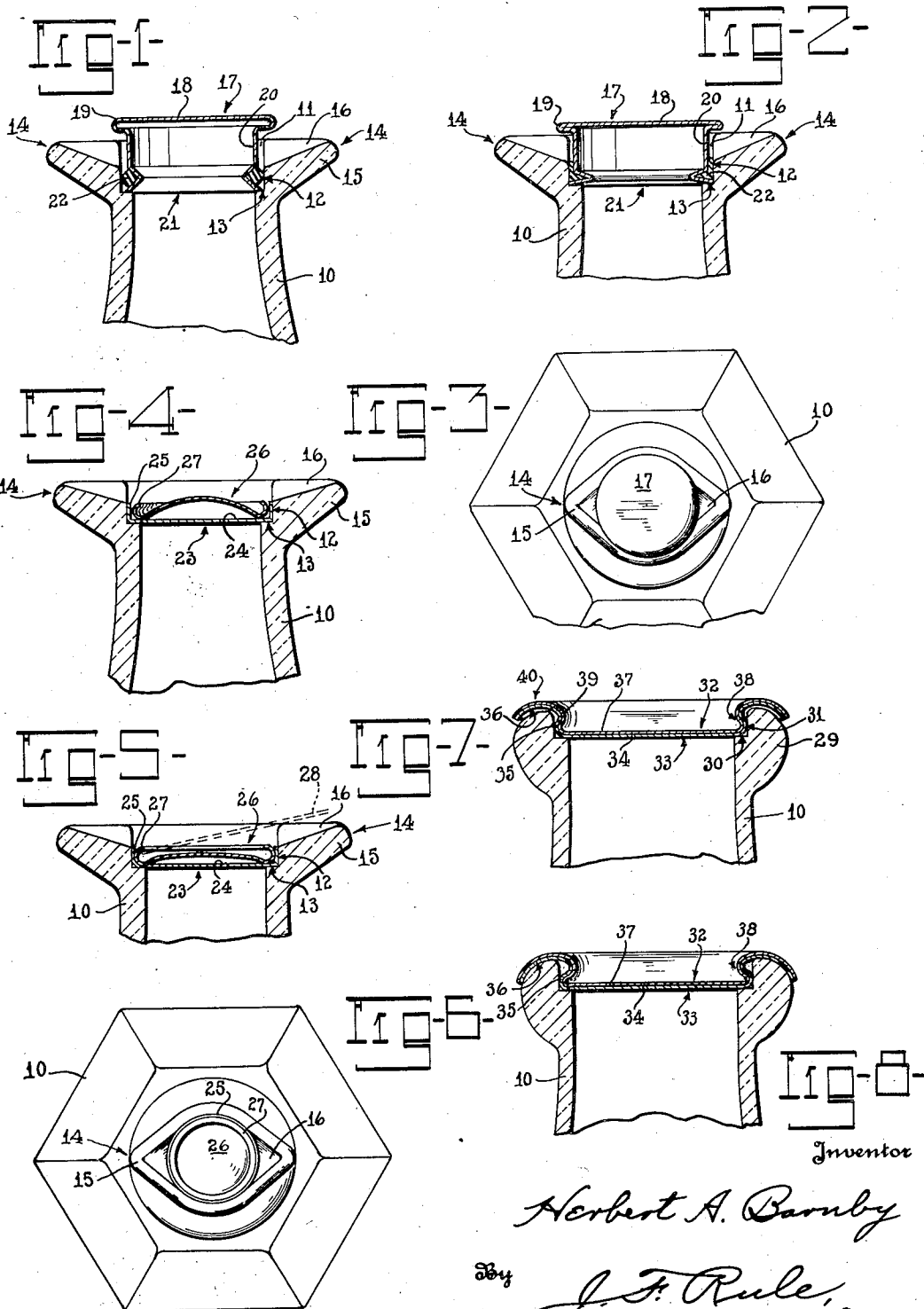

Inventor

Herbert A. Barnby

By

J. F. Rule, Attorney

# UNITED STATES PATENT OFFICE

2,018,004

## CONTAINER AND CLOSURE THEREFOR

Herbert A. Barnby, Toledo, Ohio, assignor to  
Owens-Illinois Glass Company, a corporation  
of Ohio

Application April 12, 1933, Serial No. 665,705

2 Claims. (Cl. 215—52)

The present invention relates to improvements in bottles and the like containers and closures therefor.

In order to facilitate dispensing of certain products which are packed in bottles and the like glass containers, a pour out finish or pouring spout forming an integral part of the container has been found distinctly advantageous. Such a spout ordinarily includes an open radially extending channel or trough in the upper surface of the wall defining the filling opening or mouth of the container. Preferably the trough extends outwardly beyond the circle defined by the exterior surface of the finish or wall of the filling opening in order that it may perform its function with the utmost satisfaction and efficiency. While this construction is greatly desired it has until the advent of the herein disclosed invention, been more or less impractical commercially because it prohibits the use of the conventional screw type closure and in fact any really satisfactory seal. The usual cork stopper is generally unsatisfactory and particularly so where hot products such for example as sirup, are being packaged, because the internal pressure created in the properly filled containers as the stopper is inserted forces the stopper out of the filling opening.

An object of the present invention is the provision of a bottle or similar container having an integral pouring spout and an uninterrupted internal sealing surface for engagement with the closure, said sealing surface disposed in its entirety in a plane below the spout.

Another object is the provision of a complete package consisting of a bottle or similar container having an internal sealing surface in the filling opening and a closure designed for radial expansion in said opening into sealing contact with the internal sealing surface, such expansion being effected by the application of top pressure to the closure.

Another object is the provision of a closure designed to fit into the filling opening of a bottle or the like container having a pouring spout, and means whereby top pressure on the closure expands portions thereof radially into sealing contact with an internal vertical sealing surface disposed in a plane below said spout.

Other objects will be in part apparent and in part pointed out hereinafter.

In the drawing:

Figs. 1, 2, and 3 illustrate one form of the present invention. Fig. 1 is a fragmentary sectional view showing the closure resting freely in the

filling opening of a bottle. Fig. 2 is a similar view showing the closure attached to the bottle. Fig. 3 is a fragmentary top plan view.

Figs. 4, 5, and 6 illustrate another form of the invention. Fig. 4 is a fragmentary sectional view showing the closure fitting loosely in the filling opening. Fig. 5 shows the closure in sealing engagement with the container. Fig. 6 is a top plan view thereof.

Figs. 7 and 8 are sectional views of another form of the invention. Fig. 7 shows the closure resting loosely in the filling opening of the container while Fig. 8 shows the closure in sealing position.

In Figs. 1, 2, and 3, illustrating one form of the present invention, the bottle 10 includes a circular filling opening 11 or mouth, the inner wall of which is provided with a continuous vertical sealing surface 12 terminating at its lower end in a continuous horizontal ledge 13 or seat. If preferred, diametrically opposed pouring spouts 14 or troughs are provided, each pouring spout consisting of a lip 15 extending radially outward beyond the circle defined by the external surface of the wall of the filling opening and a channel 16 or trough increasing in depth toward its inner end and terminating in the vertical sealing surface 12.

The closure 17 involved in that form of the invention shown in Figs. 1, 2, and 3, is formed of light sheet metal and consists of a circular top portion 18 connected by means of an external hollow collapsible bead 19 to a depending flange 20. An internal collapsible bead 21 is provided at the lower margin of the flange 20, said bead being substantially V-shaped in cross section and providing a continuous external channel designed to receive a compressible sealing ring 22 which may be formed of rubber or some suitable composition. The hollow bead 19 referred to heretofore extends radially outward and is collapsible to form a relatively wide pry-off ledge when the closure and container are completely assembled.

In assembling a closure and container of the above types, the closure is first placed in the filling opening (Fig. 1) resting freely upon the ledge 13 with the circular top portion and a part of the depending flange projecting a short distance above the top surface of the container. By means of any suitable apparatus top pressure is applied uniformly to the circular top portion 18 with the result that both the external and internal beads 19 and 21 respectively, are collapsed substantially as shown in Fig. 2. Thus the external bead 19 provides a ledge spaced a short distance above the top surface of the bottle whereby to facilitate

removal of the closure through the medium of a lever (not shown) one end of which may be inserted between said ledge and top surface of the bottle. Collapse of the internal bead 21 distorts the sealing gasket 22 and forces portions thereof

radially outward into snug engagement with the vertical sealing surface 12 of the filling opening. In Figs. 4, 5, and 6, another form of closure is illustrated in which the sealing member 23 or gasket assumes the form of a cup comprising a circular bottom portion 24 and an upstanding flange 25 about its margin. A combined gasket compressing and holding device 26 is adapted to be placed in said cup and expanded laterally in a fashion to compress portions of the gasket between its marginal areas and the sealing surface 12 and ledge 13 of the container 10. This device assumes the form of a concavo-convex disk formed of light sheet metal, the margin of this disk being rolled upwardly and inwardly to form a hollow bead 27 substantially semi-circular in cross section, which bead functions as a pry-off ledge when the closure is to be removed from the container. In applying this closure to a bottle or the like container the gasket and compressing device are assembled as shown in Fig. 4. Through the medium of any suitable device, top pressure is applied to the central areas of the disk 26, the top pressure being sufficient to partially flatten or crush the central areas of the disk and slightly expand the bead 27. This results in compression of the gasket between the hollow bead 27 and the vertical sealing surface 12 as well as the horizontal ledge 13 which in this second form of the invention provides a sealing surface in addition to functioning as a ledge upon which the closure rests. During application of the closure the relation between the central areas of the disk and the hollow bead 27 changes sufficiently to increase the extent of overhang of the top portion of the bead so that it will function efficiently as a pry-off ledge beneath which a lever 28 or some suitable prying implement may be inserted in order to facilitate removal of the closure.

In another form (Figs. 7 and 8) the container 10 is provided with a conventional milk bottle or other suitable finish consisting of an annular bead 29 extending entirely around the filling opening and provided with an internal horizontal ledge 30, said ledge arranged at the lower margin of a continuous vertical sealing surface 31. In this form of the invention a pouring lip or spout is not involved.

The closure as shown in Figs. 7 and 8 consists of inner and outer cups 32 and 33 respectively, which may be adhered and fabricated together, the latter cup functioning as a sealing gasket and formed of comparatively heavy water proof paper or other suitable material. This outer cup includes a circular bottom portion 34 provided about its margin with an upstanding flange 35 adapted for engagement with the vertical sealing surface 31 of the container, said flange having its upper marginal portion 36 curved radially out-

ward and substantially conforming to the curvature of the upper part of the bead 29. The other cup 32 functions as a gasket compressing and holding medium in that it serves to compress portions of the gasket 33 into snug contact with the ledge 30 and sealing surface 31 of the container and hold them against premature movement relative to the sealing surface. This cup 32 is formed of light flexible sheet metal and includes a circular bottom portion 37 and an upstanding continuous flange 38 about the margin thereof, said flange including an inwardly curved annular bead 39 and an outwardly directed marginal portion 40 above the bead and overlying the corresponding portion of the outer cup or gasket 33. It is evident that with this type of closure the metal cannot come in contact with the contents. This is a distinct advantage in packaging certain products.

In assembling a closure and container of the above type, the closure is first placed in the filling opening upon the ledge 30 as shown in Fig. 7. Thereafter, by means of a suitable device (not shown) top pressure is applied to the marginal portions 40 of the closure with the result that the bead 39 is forced radially inward and that portion of the flange below the bead is expanded. The compresses portions of the gasket between the inner cup and the vertical sealing surface 31 and ledge 30 of the container. The closure when in sealing position assumes the form illustrated in Fig. 8 in which the bead 39 in effect provides a lip beneath which a prying implement may be inserted to facilitate removal of the closure.

Modifications may be resorted to within the spirit and scope of the appended claims.

What I claim is:

1. A closure comprising a circular top portion, a continuous flange depending from the margin thereof, an internal collapsible bead at the lower margin of said flange providing an external channel, and a gasket arranged in said channel, the walls of said channel prior to collapse thereof being disposed substantially at right angles to each other.

2. A closure comprising a circular top portion, a depending continuous flange at the margin of said top portion, a sealing gasket arranged at the lower margin of said flange for contact with a vertical sealing surface on the interior of a bottle neck, and collapsible means adapted to seat on an interior horizontal ledge of the said neck whereby top pressure on the closure compresses the gasket between said flange and said sealing surface, and a continuous external collapsible bead connecting said top portion and flange, said bead when collapsed being spaced a short distance from a filling opening to which the closure is applied and functioning as a pry-off ledge, said collapsible means consisting of an annular channel, the walls of which prior to collapse, are disposed substantially at right angles to each other.

HERBERT A. BARNBY.