

E. B. BIGELOW.
Loom for Weaving Pile Fabrics.

No. 167,152.

Patented Aug. 31, 1875.

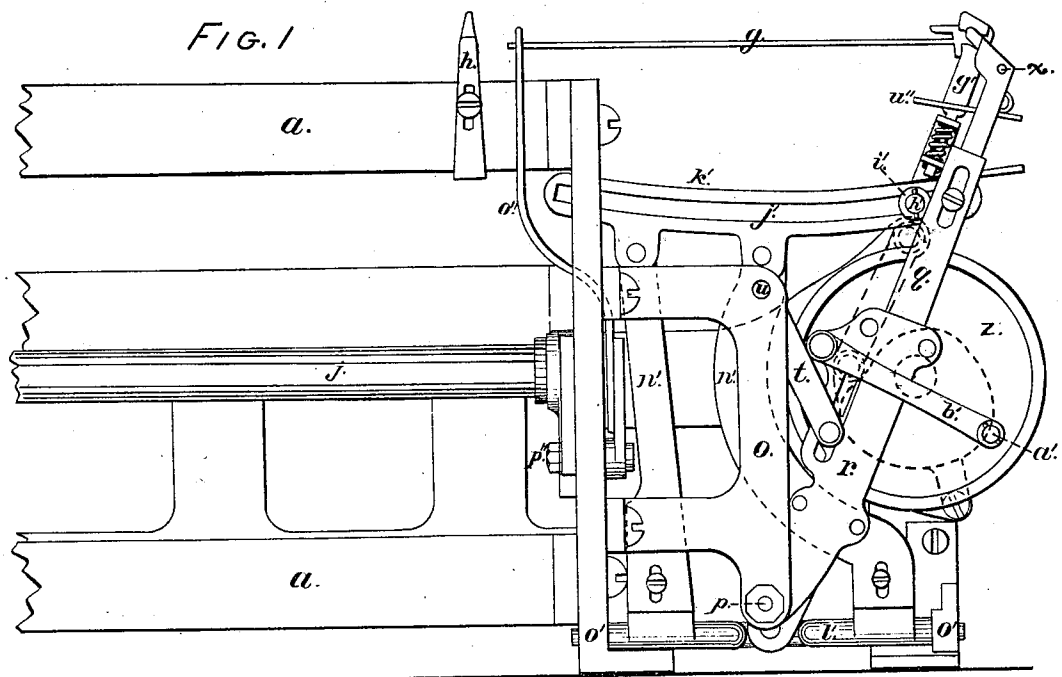
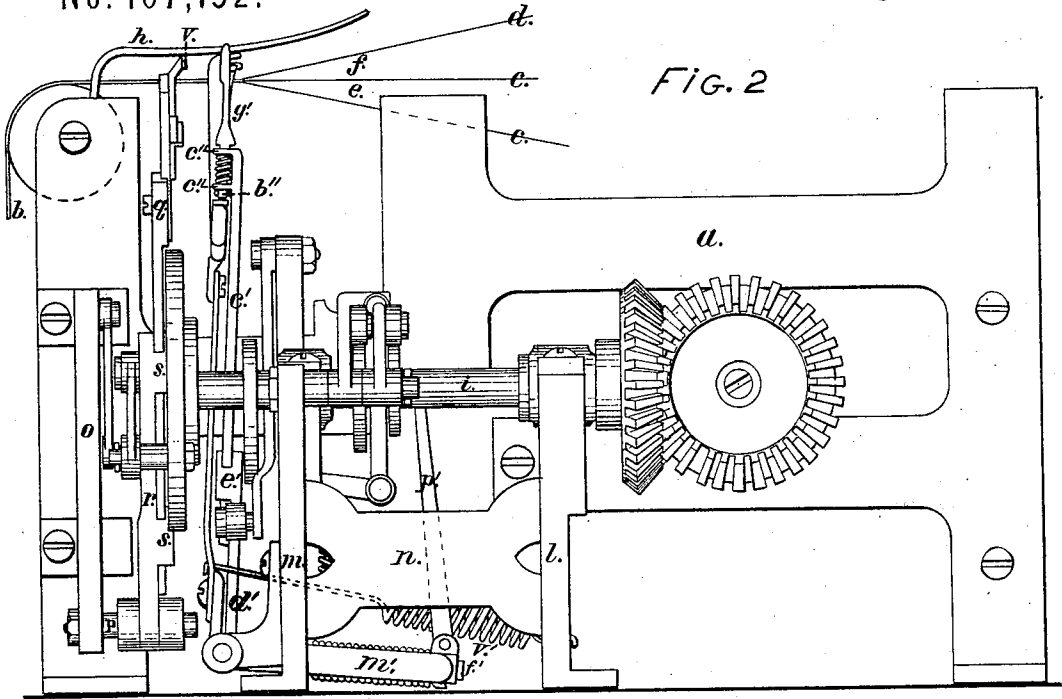

WITNESSES;
John J. Whitman.
Eliza F. Bigelow

INVENTOR;
Erastus Brigham Bigelow.

E. B. BIGELOW.

Loom for Weaving Pile Fabrics.

No. 167,152.

Patented Aug. 31, 1875.

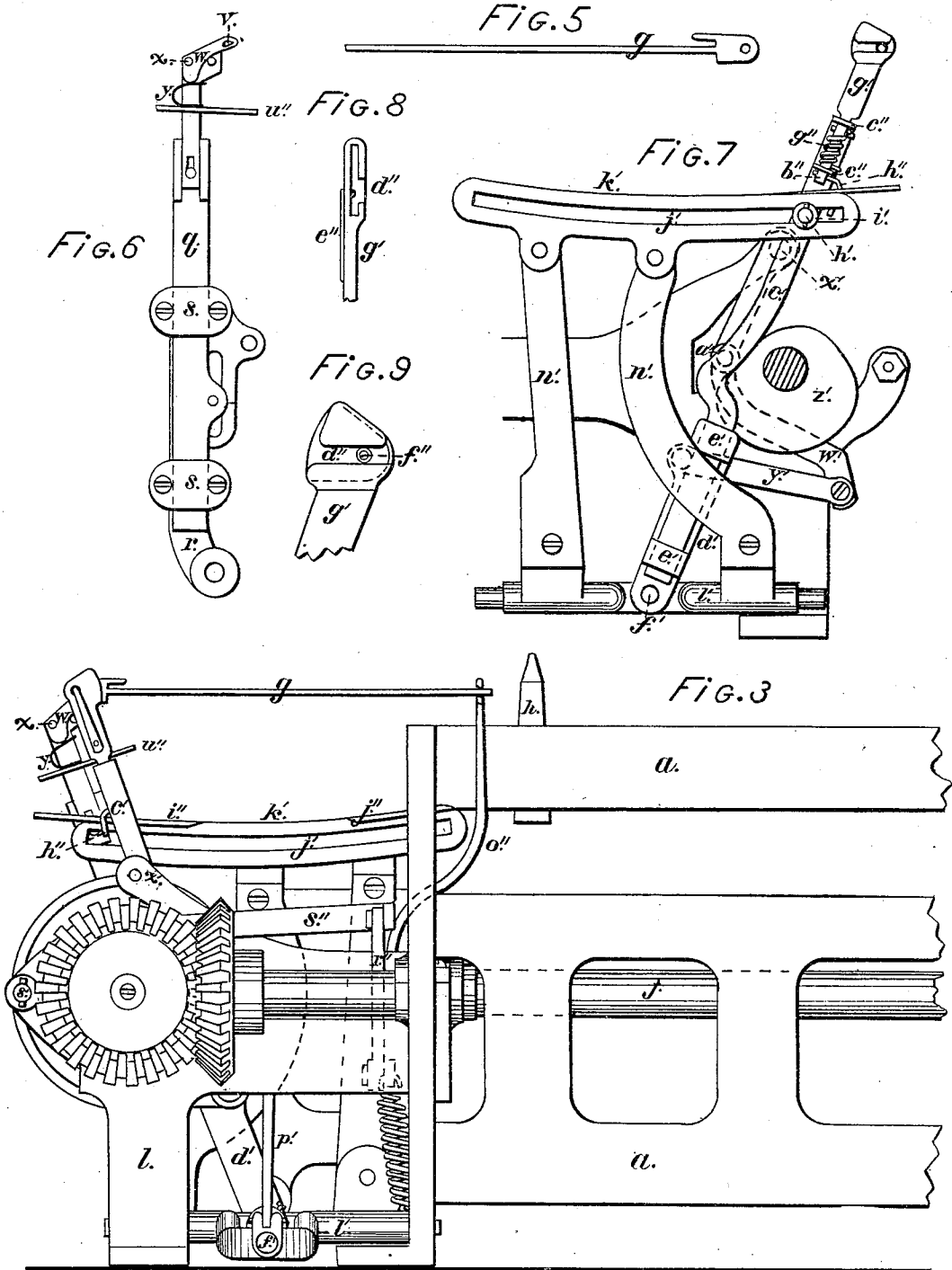

WITNESSES;
 John T. Whitman.
 Eliza F. Bigelow.

INVENTOR;
 Erastus Brigham Bigelow.

E. B. BIGELOW.

Loom for Weaving Pile Fabrics.

No. 167,152.

Patented Aug. 31, 1875.

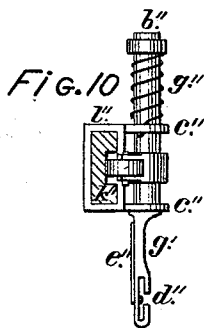
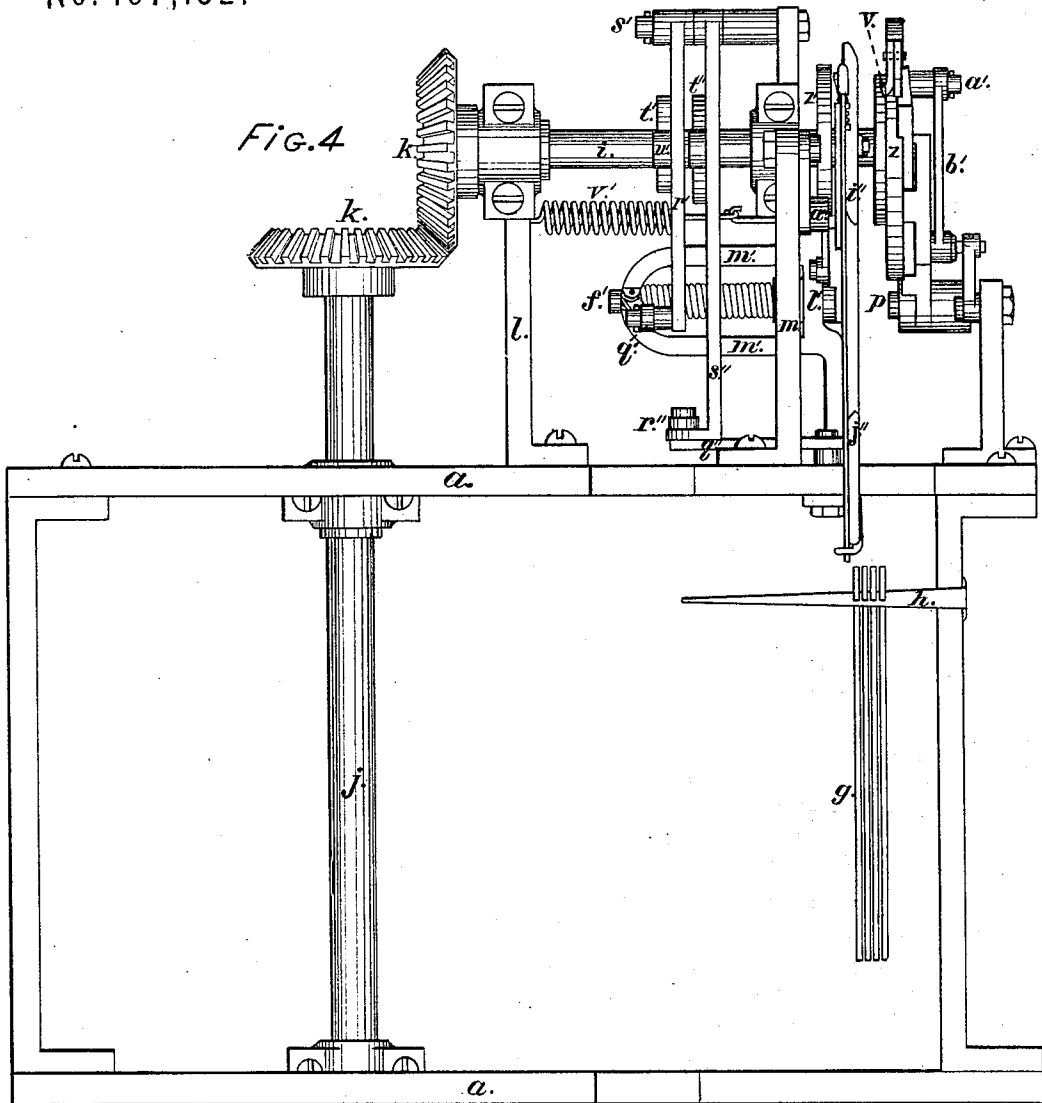

FIG. 10

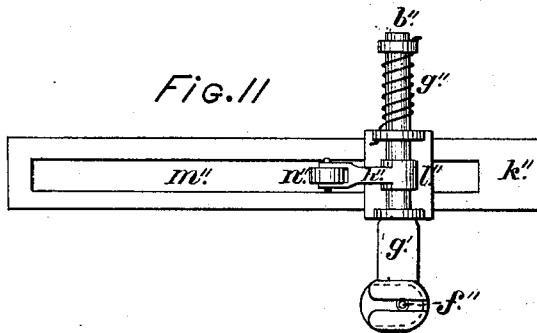

FIG. 11

WITNESSES;
 John T. Whitman.
 Eliza F. Bigelow

INVENTOR;
 Erastus Brigham Bigelow.

UNITED STATES PATENT OFFICE.

ERASTUS B. BIGELOW, OF BOSTON, MASSACHUSETTS.

IMPROVEMENT IN LOOMS FOR WEAVING PILED FABRICS.

Specification forming part of Letters Patent No. **167,152**, dated August 31, 1875; application filed July 14, 1875.

To all whom it may concern:

Be it known that I, ERASTUS BRIGHAM BIGELOW, of Boston, in the county of Suffolk and Commonwealth of Massachusetts, have invented an Improvement in Looms for Weaving Piled Fabrics, of which the following is a specification:

My invention relates to the mechanism for operating the pile-wires, and is represented by the accompanying drawings, which form a part of the specification.

Figure 1 is a front elevation of my improved mechanism, and such other parts of a loom as are necessary to illustrate its construction and operation. Fig. 2 is a right-hand elevation of the same; Fig. 3, a rear elevation; and Fig. 4, a plan.

The object of my invention is to simplify the construction of the mechanism and to facilitate the passage of the pile-wires into the shed of the warps.

A part of my invention consists in the employment of two oscillating staffs to operate the pile-wires, one to carry the withdrawing-hook and the other the inserting-receiver, or its equivalent, and also in the mode of constructing and operating said staffs.

In order that the pile-wires may pass properly into the shed of the warps it is necessary that their inner ends should be directed toward its deepest part while being inserted, and then swung toward the cloth-forming line as the inserting operation is being completed. Heretofore the inserting-receiver or its equivalent has had but two movements, one toward and from the lay and another toward and from the cloth, the direction of the latter movement being sometimes inclined slightly toward the reed. I find, in practice, that by giving it an additional movement irrespective of the direction of its other movements a better result is obtained. Another part of my invention, therefore, consists in giving to the inserting-receiver or its equivalent an oscillating movement in addition to its two usual movements, whereby any desired lateral movement may be given to the inner ends of the pile-wires while they are being inserted, whatever may be the direction in which said inserting-receiver or its equivalent may be moved toward the cloth. This part of my invention is applicable, and I in-

tend to apply it, to inserting-receivers or their equivalents carried by slides or slide-bars, as well as to those carried by oscillating staffs.

The frame of the loom to which my improved wire-operating mechanism is applied is indicated in the drawings by *a*, the cloth by *b*, the ground-warp by *c*, and the figure-warp by *d*, the shed for the passage of the shuttle by *e*, and the shed for the reception of the pile-wires by *f*, the two sheds being represented in the position given them at the time a pile-wire is inserted and the shuttle thrown. The pile-wires *g* are formed with heads, as is usual, and as shown in Fig. 5. A series of them, as they are held in position by the guard *h* and lie in the cloth during the operation of weaving, is represented in Fig. 4.

My improved mechanism, which acts in succession on the forward one of the series, will now be described. It is actuated by a shaft, *i*, which receives motion from the cam-shaft *j* through the action of the bevel-gears *k*. The shaft *i* is supported by two stands, *l* and *m*, which are held together by a girt, *n*. The withdrawing-staff, which, at its upper end, carries the withdrawing-hook, is held in position by a stand, *o*, and oscillates on a stud, *p*, affixed thereto.

Now, it will be obvious that if the distance between the upper end of the staff and the stud *p* remains constant, the withdrawing-hook as the staff oscillates toward and from the cloth would move in an arc of a circle corresponding to the radius thus formed; whereas it is necessary that it should move more nearly in a horizontal plane. To effect this result I make the staff in two parts, which are respectively indicated by *q* and *r*. The upper part *q* is connected with the lower part *r* in such a manner as to be capable of moving up and down in the guide-bearings *s*, (see Fig. 6,) and to sustain it in its proper vertical position and to cause its upper end to move toward and from the cloth in the required horizontal plane a bar or link, *t*, is employed, the lower end of which is jointed to the part *q* while its upper end is supported by, and oscillates on, a stud, *u*, affixed to the stand *o*, before mentioned, the several parts co-operating on the principle of the well-known "parallel motion." The length of the bar or link

t and the position of the axis on which it oscillates are so adjusted with respect to each other as to cause the upper end of the oscillating staff as it draws out a wire to rise above the plane of the wires in the cloth and elevate the wire to the proper position to enter the shed f . The withdrawing-hook v is formed on the rear side of a lever-arm, w , which is jointed at x to an adjustable bar on the upper end of the part g of the withdrawing-staff. It is formed on the lever-arm instead of the end of the staff, in order that by swinging the lever-arm into a vertical position the hook may be prevented from drawing out the pile-wires when the loom is turned to restore a "lost pick." A spring, y , holds the lever-arm when at rest in its vertical or horizontal position. The withdrawing-staff is moved toward and from the cloth by the shaft i before-mentioned, the motion being transmitted through the medium of the disk z , stud a' , and connecting-bar b' ; and when it has nearly completed its movement toward the cloth the hook engages the wire-head, as is usual, and when it moves from the cloth it draws out a wire and delivers it to the inserting mechanism, which will now be described.

A front view of the inserting mechanism is represented in Fig. 7 detached from the loom. The inserting-staff is made in two parts, which are respectively designated c' and d' . The part c' is connected with the part d' in such manner as to be capable of moving up and down freely in the guide-bearings e' , and for the same purpose that the two parts of the withdrawing-staff before described are similarly connected. The lower part d' is affixed to a horizontal axis, f' , which will hereinafter be described. The upper part c' , with which the inserting-receiver or its equivalent g' is connected, is held in its vertical position and caused to move toward the cloth in a proper plane for inserting the pile-wires by a stud, h' , which carries a roller, i' , which traverses a slot, j' , formed in the bar k' .

By this arrangement it will be seen that the plane in which the inserting-receiver moves may be varied to any desired extent by a corresponding variation of the slot j' . Instead of the stud h' , roller i' , and slot j' , for keeping the inserting-receiver in the required plane I sometimes substitute a bar or link similar to that used in connection with the withdrawing-staff, as before described.

The inserting-receiver, or its equivalent, has three movements, one toward and from the lay to successively receive the pile-wires from the withdrawing-hook, and carry them from the line where they are drawn from the cloth to the line where they are inserted in the warps, another toward and from the cloth to insert them, and another to direct their inner ends toward the reed or deepest part of the shed while being inserted, and to swing them toward the cloth-forming line as the inserting operation is being completed. These movements are effected respectively as follows: The

mechanism connected with the inserting-receiver is supported by a frame consisting of an axis, l' , and a bow projection, m' , on its rear side, as shown in Fig. 4. Two standards, marked n' , are affixed to the axis l' , and supported at their upper ends the slotted bar k' , before described.

The axis l' is supported by bearings o' , and is capable of oscillating therein. The axis f' , before mentioned, to which the lower part d' of the inserting-staff is affixed, is supported by bearings formed in the axis l' , and bow-projection m' , and is capable of oscillating therein. From this description it will be readily seen that by oscillating the axis l' the inserting-receiver g' will be moved toward and from the lay, and that by oscillating the axis f' it will be moved toward and from the cloth. To the rear end of the bow-projection m' the lower end of a rod, p' , is jointed, while its upper end is jointed at q' to the inner end of a lever-arm, r' , which oscillates on a stud, s' . A cam, t' , on the shaft i acts on a roller, w' , on the side of the lever-arm r' , and thus turns the axis l' , and moves the inserting-receiver from the reed, while a spring, v' , draws it in the opposite direction when the cam t' allows it to do so. A bent lever-arm, w' , oscillates on a stud, x' , and is connected by a bar, y' , to the lower part d' of the oscillating staff. A cam, z' , acts on a roller, a'' , on the side of the lever-arm w' , and moves the inserting-receiver toward the cloth, while the coiled spring on the axis f' draws it in an opposite direction, a grooved cam being sometimes employed which moves it in both directions. The inserting-receiver g' is formed on a spindle, b'' , which is capable of oscillating in bearings c'' projecting from the front side of the upper part c' of the inserting-staff. Its socket, which receives the pile-wire heads from the withdrawing-hook, is represented by Fig. 8 and Fig. 9, Fig. 9 being an enlarged front view, and Fig. 8 an edge view, showing its mouth, which is slightly beveled to facilitate the entrance of the wire heads. The mouth of the socket is also made wider than its bottom, as is indicated by the dotted lines in Fig. 9, in order that the wire heads may retain their horizontal position, while the angle of the staff is changed by its movement toward the cloth. The front side piece of the socket is cut out at d'' for a passage for the withdrawing-hook as it draws in a wire head. To prevent the wire heads from escaping unduly from the socket, and yet not hold them so firmly but that the socket can readily be withdrawn without displacing the pile-wires, a spring, e'' , is affixed to the rear side piece of the socket, on the upper end of which a convex face, f'' , is formed, which passes through said rear side piece into the path of the wire head. Now, it will be obvious that as a wire head is drawn into the socket the convex face of the spring will yield to its pressure until the hole in the wire head on which it acts is brought in range with it, when it will engage

therewith and hold the pile-wire in position while being inserted, though not so firmly but that the receiver, as it returns for a succeeding wire, is readily withdrawn from it.

The movement of the inserting-receiver or its equivalent, whereby the inner ends of the pile-wires are directed toward the reed or deepest part of the shed while they are being inserted therein, and swung toward the cloth-forming line as the inserting operation is being completed, is imparted to it as follows, viz: The spindle b'' , on which the inserting-receiver is formed, has a helical spring, g'' , surrounding it, which constantly tends to turn the mouth of the receiver toward the reed, though its movement in that direction is limited by a fixed stop. To the lower end of the spindle b'' a bent lever-arm, h'' , is affixed, the depending arm of which, at appropriate intervals, acts on cam-surfaces i'' and j'' , which are affixed to the slotted bar k'' , before described. When the inserting-receiver is at the outward stage of its movement in which it is represented in Fig. 7, its mouth is on the line on which the pile-wires are drawn from the cloth and delivered to it; then, when the receiver has started on its movement toward the cloth to insert the wire the cam-surface i'' allows the spring g'' to turn the spindle b'' to the fixed stop before mentioned, and thus direct the inner end of the wire toward the reed, in which relative position the receiver and the wire continue their movement until the depending arm of the lever h'' reaches the cam-surface j'' , which turns the receiver back to its former position, and swings the inner end of the wire toward the cloth-forming line as the inserting operation is being completed. A mode of effecting these movements of the inserting-receiver, when it is carried by a slide and a slide-bar, is represented in Fig. 10 and Fig. 11. The slide-bar k'' is traversed by the slide l'' , as is usual, and the spindle b'' of the inserting-receiver g'' oscillates in bearings c'' projecting from the slide l'' , in the same manner as when it is carried by the oscillating staff just described. In the side of the slide-bar k'' a recess, m'' , is formed, the bottom of which is shaped in accordance with the oscillating movement required to be given to the receiver. The lever-arm h'' carries a roller, n'' , which rests on the bottom of the recess m'' . The helical spring g'' on the spindle b'' constantly tends to press the roller against the bottom of the recess, so that as the receiver is moved toward the cloth to insert a wire it oscillates in accordance with the form of the bottom of the recess. The inner ends of the pile-wires are transferred from the line where they are drawn from the cloth to the point where they are inserted, by a carrier, o'' , as usual.

It starts on its movement toward the lay in unison with the inserting-receiver, which carries the outer end of the pile-wires, though it moves a greater distance than the inserting-receiver, thus deflecting the pile-wires to the point of insertion, as is usual. The carrier o'' oscillates on a stud, p'' , and is affixed to a horizontal arm, q'' , which is connected by a bar, r'' , to a lever-arm, s'' , which oscillates on the stud s' , and is actuated by a cam, t'' , on the shaft i . But as this part of the mechanism forms no part of my invention a further description of it is deemed unnecessary. The withdrawing-hook and the inserting-receiver co-operating, withdraw and insert a pile-wire at every two beats of the lay. When the former has engaged a wire, and nearly completed its movement from the cloth, the latter takes a position by its side, and by pressing against a guide-bar, u'' , on the withdrawing-staff, the two parts are kept in such relation to each other that the hook, moving a little faster than the receiver, draws the wire-head into the socket of the receiver. Thus armed with a wire, it moves back toward the lay to the line of insertion, then toward the cloth, and inserts the wire, as hereinbefore explained.

It will be obvious to those accustomed to construct machinery that the form and arrangement of many of the parts above described may be varied without departing from the principles of my invention.

I am aware that an oscillating staff has been used to carry the inserting-receiver or its equivalent, in combination with a slide traversing a slide-bar to carry the withdrawing-hook, and also that a single oscillating staff has been employed to carry both the withdrawing-hook and the inserting-receiver; but the employment of two oscillating shafts, as herein set forth, I believe to be new.

What I claim as new, and desire to secure by Letters Patent, is—

1. The combination of two oscillating shafts, constructed and operated substantially as herein described, one shaft being adapted to draw the pile-wires from the cloth, and the other to insert them in the shed of the warp, substantially as specified.

2. The inserting-receiver, adapted to receive an oscillating movement toward and from the lay, in addition to its usual movements, and irrespective of the direction of its movement toward and from the cloth, substantially as and for the purpose specified.

ERASTUS BRIGHAM BIGELOW.

Witnesses:

JOHN B. WHITMAN,
ELIZA F. BIGELOW.