



(51) International Patent Classification:

F16B 2/08 (2006.01) *F16L 3/00* (2006.01)
H02G 3/32 (2006.01) *F16B 2/06* (2006.01)

(21) International Application Number:

PCT/US2022/019930

(22) International Filing Date:

11 March 2022 (11.03.2022)

(25) Filing Language:

English

(26) Publication Language:

English

(30) Priority Data:

63/175,186 15 April 2021 (15.04.2021) US

(71) Applicant: **COMMSCOPE TECHNOLOGIES LLC**
[US/US]; 1100 CommScope Place SE, Hickory, North Carolina 28602 (US).

(72) Inventors: **JOSHI, Abiral**; 3227 S. Carpenter Street, Apartment 1M, Chicago, Illinois 60608 (US). **VACCARO, Ronald A.**; 343 River Haven Drive, Taylorsville, North Carolina 28681 (US). **STOCKMAN, Christopher**; 18 Ravenglass Lane, Bella Vista, Arkansas 72714 (US).

(74) Agent: **MYERS BIGEL, P.A.**; James R. Cannon, PO Box 37428, Raleigh, North Carolina 27627 (US).

(81) Designated States (unless otherwise indicated, for every kind of national protection available): AE, AG, AL, AM,

AO, AT, AU, AZ, BA, BB, BG, BH, BN, BR, BW, BY, BZ, CA, CH, CL, CN, CO, CR, CU, CZ, DE, DJ, DK, DM, DO, DZ, EC, EE, EG, ES, FI, GB, GD, GE, GH, GM, GT, HN, HR, HU, ID, IL, IN, IR, IS, IT, JM, JO, JP, KE, KG, KH, KN, KP, KR, KW, KZ, LA, LC, LK, LR, LS, LU, LY, MA, MD, ME, MG, MK, MN, MW, MX, MY, MZ, NA, NG, NI, NO, NZ, OM, PA, PE, PG, PH, PL, PT, QA, RO, RS, RU, RW, SA, SC, SD, SE, SG, SK, SL, ST, SV, SY, TH, TJ, TM, TN, TR, TT, TZ, UA, UG, US, UZ, VC, VN, WS, ZA, ZM, ZW.

(84) Designated States (unless otherwise indicated, for every kind of regional protection available): ARIPO (BW, GH, GM, KE, LR, LS, MW, MZ, NA, RW, SD, SL, ST, SZ, TZ, UG, ZM, ZW), Eurasian (AM, AZ, BY, KG, KZ, RU, TJ, TM), European (AL, AT, BE, BG, CH, CY, CZ, DE, DK, EE, ES, FI, FR, GB, GR, HR, HU, IE, IS, IT, LT, LU, LV, MC, MK, MT, NL, NO, PL, PT, RO, RS, SE, SI, SK, SM, TR), OAPI (BF, BJ, CF, CG, CI, CM, GA, GN, GQ, GW, KM, ML, MR, NE, SN, TD, TG).

Published:

— with international search report (Art. 21(3))

(54) Title: ADAPTER FOR MOUNTING CABLE HANGERS

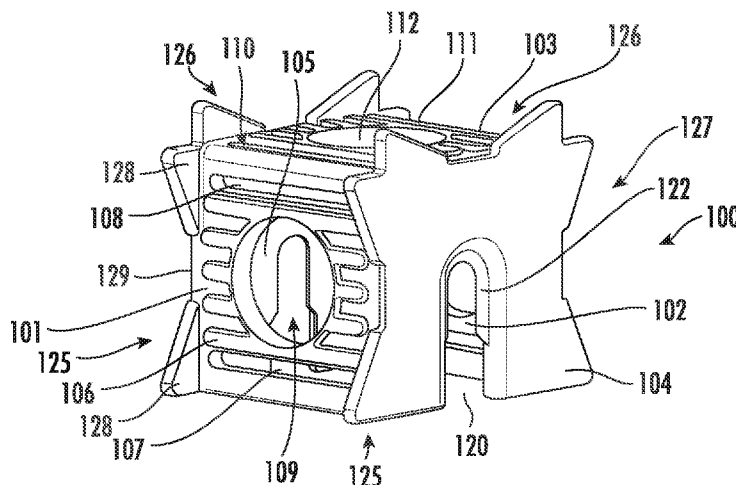

FIG. 9

(57) Abstract: An adapter for a cable hanger includes: first and second opposed side walls; a ceiling spanning the first and second side walls; and first and second end walls spanning the first and second side walls and merging with the ceiling. At least one of the first and second side walls and the ceiling includes a mounting hole. At least one cradle is mounted to and extends away from one of the first or second side walls, the first or second ends walls, or the ceiling.



ADAPTER FOR MOUNTING CABLE HANGERS

Related Application

[0001] The present application claims priority from and the benefit of U.S. Provisional Patent Application No. 63/175,186, filed April 15, 2021, the disclosure of which is hereby incorporated herein by reference in full.

Field of the Invention

[0002] The present invention relates generally to devices for supporting cables and, in particular, to hangers for securing cables to support structures.

Background of the Invention

[0003] Cable hangers are commonly used to secure cables to structural members of antenna towers and other structures. Generally, each cable is attached to a structural member by cable hangers mounted at periodically-spaced attachment points.

[0004] Antenna towers may be crowded due to the large numbers of cables required for signal-carrying. Over time, as systems are added, upgraded and/or expanded, installation of additional cables may be required. To conserve space, it may be desirable for each set of cable hangers to secure more than a single cable. Certain cable hangers have been constructed to secure multiple cables; other cable hangers have a stackable construction that permits multiple cable hangers to be interlocked extending outwardly from each mounting point/structural member. Stacked and multiple-cable hangers significantly increase the number of cables mountable to a single attachment point.

[0005] One popular stackable cable hanger is discussed in U.S. Patent No. 8,191,836 to Korczak, the disclosure of which is hereby incorporated herein in its entirety. Hangers disclosed therein have generally a U- or C-shaped profile with rounded arms. A locking projection extends from the free end of each arm, and the “root” of the hanger that spans the fixed ends of the arms has a large aperture. The hanger can hold a cable between the arms; gripping of the cable is enhanced by short fingers that extend inwardly from the arms to engage the cable. Hangers can be “stacked” onto each other by inserting the locking projections of one hanger into the large aperture of the next hanger.

[0006] One variety of cable hanger of this type is the SNAP-STAK® hanger, available from CommScope, Inc. (Joliet, Illinois). Other cable hangers are shown in U.S. Patent Nos. 9,866,004, 9,853,434, and 9,903,510, the disclosures of each of which are hereby incorporated herein by reference in full.

[0007] Another available stackable cable hanger is discussed in U.S. Patent Publication No. 2018/0045336 to Vaccaro, the disclosure of which is hereby incorporated herein by reference in its entirety. This cable hanger (versions of which are available from CommScope, Inc. under the name SNAPTAK) is formed of a polymeric material and is typically employed for smaller cables. In addition, the polymeric SNAPTAK hanger can reduce or eliminate passive intermodulation (PIM) near an antenna. PIM, which can negatively impact antenna performance, can be caused by a variety of factors, one of which is metal-to-metal interfaces of components near the antenna. Using a polymeric hanger that is mounted on a metallic antenna mount or other structure can eliminate potential PIM that might otherwise be caused by a metal hanger mounted to a metal antenna leg.

[0008] In some instances, it may be desirable to mount multiple stacks of cable hangers in close proximity. In such instances, it may be desirable to employ an adapter, such as that shown at **10** in **FIG. 1**. The adapter **10** has a trapezoidal profile, with a base panel **12** and three serially-attached mounting panels **14**. Each of the mounting panels **14** includes a mounting hole **16** (typically a nominal $\frac{3}{4}$ inch hole) that can receive a cable hanger such as those described above, one of which is designated **20** in **FIG. 2**. The base panel **12** of the adapter **10** has a hole **18** that can be used to mount the adapter **10** to a mounting structure via a bolt. The base panel **12** also includes slots **22** on either side of the hole **18** that can receive a hose clamp **26** or the like to

mount the adapter **10** to a pole **24**, as shown in **FIG. 3**. This mounting approach may be desirable when the pole **24** has no pre-formed holes to receive a typical cable hanger.

[0009] Another prior art adapter **300** is illustrated in **FIGS. 4-8** and comprises a housing **302** and a securing screw **304**. The housing **302** includes a floor **310**, a rear wall **312**, a ceiling **314**, and side walls **316**. These structures are arranged to form generally a cube with an open front side. Each of the side walls **316** has a slot **318** that is open at its front end. Teeth **320** are present in the lower edge of each slot **318** to improve grip. The ceiling **314** has an opening **322** with threads **324**. The floor **310** also has a mounting hole **326**. As can be seen in **FIG. 5**, the rear wall **312** has a mounting hole **328** that is sized and configured to receive a cable hanger in the manner of the adapter **10** above. Typically, the mounting holes **326**, **328** have a nominal $\frac{3}{4}$ inch diameter.

[0010] As can be seen in **FIGS. 6** and **7**, the securing screw **304** can be inserted into the opening **322** in the ceiling **314** of the housing **302**. The threads **324** of the opening **322** mesh with the threads **342** of the screw **304**. Referring now to **FIG. 8**, the adapter **300** is illustrated mounted on a mounting structure **370**, such as the rung of a ladder. The housing **302** of the adapter **300** is attached to the mounting structure **370** by aligning the slots **318** in the side walls **306** of the housing **302** with the mounting structure **370**, and slipping the housing **302** onto the mounting structure **370** so that the mounting structure **370** is received in the slots **318**. Once the mounting structure **370** is in position in the slots **318**, the securing screw **304** is rotated relative to the housing **302** to cause it to advance onto the mounting structure **370**. Movement of the securing screw **370** ceases when the lower end of the shaft **340** engages the surface of the mounting structure **370** (see **FIG. 7**). At this point a cable hanger can be mounted in either of the mounting holes **326**, **328**.

[0011] It may be desirable to provide additional configurations for mounting cable hangers, particularly to structures that may not have pre-formed holes, and particularly in a manner that can reduce or eliminate PIM.

Summary

[0012] As a first aspect, embodiments of the invention are directed to an adapter for a cable hanger. The adapter comprises: first and second opposed side walls; a ceiling spanning the first and second side walls; and first and second end walls spanning the first and second side walls

and merging with the ceiling. At least one of the first and second side walls and the ceiling includes a mounting hole. Each of the first and second end walls includes an open-ended recess, and the open-ended recess is lined at its upper portion with a thin lip.

[0013] As a second aspect, embodiments of the invention are directed to an adapter for a cable hanger comprising: first and second opposed side walls; a ceiling spanning the first and second side walls; and first and second end walls spanning the first and second side walls and merging with the ceiling. At least one of the first and second side walls and the ceiling includes a mounting hole. The adapter further comprises at least one cradle that is mounted to and extends away from one of the first or second side walls, the first or second ends walls, or the ceiling.

[0014] As a third aspect, embodiments of the invention are directed to an adapter for a cable hanger comprising: first and second opposed side walls; a ceiling spanning the first and second side walls; and first and second end walls spanning the first and second side walls and merging with the ceiling. At least one of the first and second side walls and the ceiling includes a mounting hole, and one of the end walls and the ceiling includes a feature for engaging a strap.

Brief Description of the Figures

[0015] **FIG. 1** is a perspective view of a prior art adapter for cable hangers.

[0016] **FIG. 2** is a top view of the adapter of **FIG. 1** with a cable hanger mounted therein.

[0017] **FIG. 3** is a perspective view of the adapter of **FIG. 1** mounted to a pole via a hose clamp.

[0018] **FIG. 4** is a perspective view of a housing of another adapter for a cable hanger.

[0019] **FIG. 5** is a front view of the housing of **FIG. 4**.

[0020] **FIG. 6** is a front view of the adapter using the housing of **FIG. 4**.

[0021] **FIG. 7** is a perspective view of the adapter of **FIG. 6**.

[0022] **FIG. 8** is a perspective schematic view of the adapter of **FIG. 6** mounted on a ladder rung.

[0023] **FIG. 9** is a perspective view of a cable hanger adapter according to embodiments of the invention.

[0024] **FIG. 10** is an end view of the adapter of **FIG. 9**.

- [0025] FIG. 11 is an end perspective view of the adapter of FIG. 9 mounted on a mounting structure.
- [0026] FIG. 12 is an end perspective view of the adapter of FIG. 9 mounted on a pole with a strap.
- [0027] FIG. 13 is a perspective view of an insert usable with the adapter of FIG. 9 to mount a threaded rod on the adapter.
- [0028] FIG. 14 is an end view of the insert of FIG. 13 with a hex nut inserted in the receptacle.
- [0029] FIG. 15 is a bottom view of the adapter of FIG. 9 with the insert of FIG. 13 in place, and with a threaded rod threaded into the nut captured in the receptacle of the insert.
- [0030] FIG. 16 is an end view of the assembly of FIG. 15.
- [0031] FIG. 17 is an end perspective view of the adapter of FIG. 9 employed for the mounting of two grommets, wherein the adapter is mounted to a pole via a strap.
- [0032] FIG. 18 is a perspective view of a cable hanger adapter according to alternative embodiments of the invention.
- [0033] FIG. 19 is an end view of the adapter of FIG. 18.
- [0034] FIG. 20 is a perspective view of a cable hanger adapter according to additional embodiments of the invention.
- [0035] FIG. 21 is a side view of the adapter of FIG. 20.
- [0036] FIG. 22 is a side view of a cable hanger adapter according to further embodiments of the invention.
- [0037] FIG. 23 is a perspective view of the adapter of FIG. 20.

Detailed Description

[0038] The present invention is described with reference to the accompanying drawings, in which certain embodiments of the invention are shown. This invention may, however, be embodied in many different forms and should not be construed as limited to the embodiments that are pictured and described herein; rather, these embodiments are provided so that this disclosure will be thorough and complete, and will fully convey the scope of the invention to those skilled in the art. It will also be appreciated that the embodiments disclosed herein can be combined in any way and/or combination to provide many additional embodiments.

[0039] Unless otherwise defined, all technical and scientific terms that are used in this disclosure have the same meaning as commonly understood by one of ordinary skill in the art to which this invention belongs. The terminology used in the below description is for the purpose of describing particular embodiments only and is not intended to be limiting of the invention. As used in this disclosure, the singular forms "a", "an" and "the" are intended to include the plural forms as well, unless the context clearly indicates otherwise. It will also be understood that when an element (e.g., a device, circuit, etc.) is referred to as being "connected" or "coupled" to another element, it can be directly connected or coupled to the other element or intervening elements may be present. In contrast, when an element is referred to as being "directly connected" or "directly coupled" to another element, there are no intervening elements present.

[0040] Referring now to the drawings, an adapter for mounting devices used to hang cables is illustrated in **FIGS. 9** and **10** and designated broadly at **100**. The adapter **100** includes side walls **101, 102**, a ceiling **103** that spans the upper ends of the side walls **101, 102**, and two end walls **104, 105** that span the side edges of the side walls **101, 102**.

[0041] As can be seen in **FIG. 9**, each of the side walls **101, 102** includes stiffening ribs **106**. Each side wall **101, 102** further includes upper and lower slots **108, 107** near its upper and lower edges. Each side wall **101, 102** also includes a mounting hole **109** (typically the mounting hole **109** has a nominal diameter of $\frac{3}{4}$ inch).

[0042] The ceiling **103** also two slots **110, 111** near its side edges. The ceiling **103** also has a mounting hole **112** that is typically nominally $\frac{3}{4}$ inch in diameter.

[0043] Each of the end walls **104, 105** includes an elongate recess **120** that is open at its lower end. The upper end of the recess **120** is semi-circular. A thin lip **122** lines the upper end of and extends inwardly into the recess **120**. As a result, the lower end of the recess **120** is wider (typically about $\frac{3}{8}$ inch) than the upper end of the recess **120** (typically about $\frac{1}{4}$ inch).

[0044] Each of the end walls **104, 105** also includes three cradles **125, 126, 127** around its edges. Each of the cradles **125, 126, 127** includes two generally triangular supports **128** that are located on either side of a recess **129**. Cradles **125** abut the side wall **101**, cradles **126** abut the ceiling **103**, and cradles **127** abut the side wall **102**.

[0045] The adapter **100** can be formed of a variety of materials, but is typically formed of a polymeric material. Exemplary polymeric materials include acetal and nylon 6,6. The adapter **100** may be formed in any suitable manner, but ordinarily is injection-molded.

[0046] **FIG. 11** illustrates the mounting of the adapter **100** on a mounting substrate **150**, which may be a shelf, platform, ladder rung, or other structure. As seen in **FIG. 11**, the recesses **120** receive the mounting substrate **150**. For mounting substrates **150** that are wider than the distance between edges of the lip **122**, the lip **122** can partially or totally deflect to provide additional grip between the adapter **100** and the mounting substrate **150**. Once mounted, the adapter **100** can provide mounting holes **109, 112** as mounting locations for cable hangers such as those discussed above.

[0047] **FIG. 12** illustrates the mounting of the adapter **100** to a pole **160** or other structure using a strap or band **162**. As shown in **FIG. 12**, the strap **162** can be threaded through the lower slots **107** in the side walls **101, 102**, then around the pole **160** to secure the adapter **100** to the pole **160**. The mounting holes **109, 112** of the adapter **100** can then provide mounting locations for cable hangers (and/or for a threaded rod, as shown in **FIG. 12** and discussed below).

[0048] **FIGS. 13-16** also illustrates how the adapter **100** may be used as a mounting location for a threaded rod **170**. An insert **172** (shown in **FIG. 13**) has a square base **174**, a ring **176** with a circular hole **177** extending in one direction from the base **174**, and a receptacle **178** with a hexagonal opening **179** extending in the opposite direction from the base **174**. The ring **176** fits within one of the mounting holes **109, 112**, with the base **174** abutting the inner surface of the corresponding side wall **101, 102** or ceiling **103**. A threaded rod **180** can then be inserted through the hole **177** and into a nut **181** that is captured within the hexagonal opening **179** (see **FIGS. 14-16**). Because the nut **181** is prevented from rotating by the receptacle **178**, the threaded rod **180** can be threaded into the nut **181**. The threaded rod **180** can then extend through the opening **177** in the ring **176** and secured with a nut **182** to provide mounting locations for other components, such as C-clamp style cable hangers like those shown in U.S. Patent No. 7,175,138 to Low et al. (the disclosure of which is hereby incorporated by reference herein in its entirety, and those available from CommScope Technologies, LLC (Hickory, North Carolina) under the part designations SHK, DHK, and BHD).

[0049] **FIG. 17** illustrates how that adapter **100** can be used as a mounting foundation for one or more grommets **200** that can, in turn, be employed to grasp cables. Grommets are typically cylindrical with a hollow center and axial slit to enable the grommet to be fitted over a cable. In many instances, grommets are used in conjunction with cable hangers to grasp cables (see, e.g., U.S. Patent No. 9,306,380 to Vaccaro, U.S. Patent No. 10,803,978 to Wang, and U.S.

Patent Publication No. 2021/0010595 to Vaccaro, the disclosures of which are hereby incorporated herein by reference in full). The adapter **100** can provide mounting locations for cable hangers that utilize grommets, but can also provide mounting locations for grommets themselves without cable hangers.

[0050] In **FIG. 17**, grommets **200, 200'** have been positioned in the cradles **125, 126**. A strap **164** can be routed around a pole **160**, through the lower slot **107** of the side wall **101**, around the first grommet **200**, through the upper slot **108** of the side wall **101**, through the slot **110** of the ceiling **103**, around the second grommet **200'**, through the slot **111** in the ceiling **103**, and through the interior of the adapter **100** back to the pole **160**. Cables (not shown) can then be captured within the interior cavities of the grommets **200, 200'**. Of course, either of the grommets **200, 200'** may be used by itself, or a third grommet positioned in the cradle **127** may be added.

[0051] Those skilled in this art will appreciate that the adapter **100** may take different forms. One example is illustrated in **FIGS. 18 and 19** and is designated broadly at **400**. The adapter **400** is similar to the adapter **200**, but includes two semicylindrical flanges **430**, each with a lip **431**. The flanges **430** are mounted to and extend from the end walls **404, 405** just above the recesses **420**. The flanges **430** provide an alternative feature that can engage a strap or band **462** to attach the adapter **400** to a pole **460** or other mounting structure.

[0052] In addition, the adapter **400** includes feet **434** with angled surfaces **436** that extend from the lower edges of the end walls **404, 405**. As shown in **FIG. 20**, the angled surfaces **436** of the feet **434** can improve the engagement of the adapter **400** to the pole **460**.

[0053] A slightly different version of the adapter **400** is shown in **FIGS. 20 and 21** and designated broadly at **400'**. The adapter **400'** has somewhat deeper flanges **430'** and larger and generally conical lips **431'**. In addition, the adapter **400'** has chamfered lower surfaces **438** to improve engagement of the adapter **400'** with a pole to which it is mounted.

[0054] **FIGS. 22 and 23** illustrate another embodiment of an adapter, designated broadly at **500**. The adapter **500** is similar to the adapter **100**, but the side walls **501, 502** span a greater distance between the end walls **504, 505**. Also, two rectangular loops **537** extend upwardly from the ceiling **503** on each side of the mounting hole **512**. The loops **537** can provide an additional feature that can be used to engage straps or bands to mount the adapter **500** to a pole or other structure.

[0055] Those of skill in this art will appreciate that the adapters **100, 400, 500** may take other forms. For example, although the side walls of each adapter are illustrated as being substantially perpendicular to the ceiling, in some embodiments the side walls may be canted somewhat. Similarly, the end walls may be inclined or canted relative to the ceiling. Moreover, any of the side walls, end walls or ceiling may have an arcuate, rather than flat, profile.

[0056] The locations of the mounting holes, slots, and/or recesses may differ. This may particularly occur if the shapes and/or relative orientations of the side walls, end walls and ceiling differ as described above.

[0057] Further, it is contemplated that the cradles may have a shallower or deeper profile. Moreover, rather than being extensions of the end walls, the cradles may be mounted to and extend from the side walls and/or the ceiling in some embodiments. Other alternatives may also be suitable.

[0058] The foregoing is illustrative of the present invention and is not to be construed as limiting thereof. Although exemplary embodiments of this invention have been described, those skilled in the art will readily appreciate that many modifications are possible in the exemplary embodiments without materially departing from the novel teachings and advantages of this invention. Accordingly, all such modifications are intended to be included within the scope of this invention as defined in the claims. The invention is defined by the following claims, with equivalents of the claims to be included therein.

That Which is Claimed is:

1. An adapter for a cable hanger, comprising:
first and second opposed side walls;
a ceiling spanning the first and second side walls;
first and second end walls spanning the first and second side walls and merging with the ceiling;
wherein at least one of the first and second side walls and the ceiling includes a mounting hole;
wherein each of the first and second end walls includes an open-ended recess, and
wherein the open-ended recess is lined at its upper portion with a thin lip.
2. The adapter defined in Claim 1, wherein each of the first and second side wall and the ceiling includes a mounting hole.
3. The adapter defined in Claim 2, wherein each of the mounting holes has a nominal $\frac{3}{4}$ inch diameter.
4. The adapter defined in and of Claims 1-3, wherein each of the first and second side walls include upper and lower slots that are generally parallel with the ceiling.
5. The adapter defined in Claim 4, wherein the ceiling includes first and second slots that are generally parallel with the upper and lower slots of the first and second side walls.
6. The adapter defined in any of Claims 1-3, wherein each of the first and second end walls includes a cradle that extends away from one of the first or second side walls or the ceiling.
7. The adapter defined in Claim 6, where each of the first and second end walls includes three cradles, wherein a first of the three cradles abuts the first side wall, a second of the three cradles abuts the second side wall, and a third of the three cradles abuts the ceiling.
8. The adapter defined in Claim 6, wherein a grommet engages the cradle.

9. The adapter defined in Claim 8, wherein the grommet is secured to the adapter via a strap.

10. An adapter for a cable hanger, comprising:
first and second opposed side walls;
a ceiling spanning the first and second side walls;
first and second end walls spanning the first and second side walls and merging with the ceiling;
wherein at least one of the first and second side walls and the ceiling includes a mounting hole; and

and further comprising at least one cradle that is mounted to and extends away from one of the first or second side walls, the first or second ends walls, or the ceiling.

11. The adapter defined in Claim 10, where the at least one cradle is six cradles, and wherein three of the six cradles extend from each of the first and second end walls, wherein a first of the three cradles abuts the first side wall, a second of the three cradles abuts the second side wall, and a third of the three cradles abuts the ceiling.

12. The adapter defined in Claim 10 or Claim 11, wherein a grommet engages the cradles.

13. The adapter defined in Claim 12, wherein the grommet is secured to the adapter via a strap.

14. The adapter defined in Claim 10 or Claim 11, wherein each of the first and second side wall and the ceiling includes a mounting hole.

15. The adapter defined in Claim 10 or Claim 11, wherein each of the mounting holes has a nominal $\frac{3}{4}$ inch diameter.

16. The adapter defined in Claim 10 or Claim 11, wherein each of the first and second side walls include upper and lower slots that are generally parallel with the ceiling.

17. The adapter defined in Claim 16, wherein the ceiling includes first and second slots that are generally parallel with the upper and lower slots of the first and second side walls.

18. An adapter for a cable hanger, comprising:
first and second opposed side walls;
a ceiling spanning the first and second side walls;
first and second end walls spanning the first and second side walls and merging with the ceiling;
wherein at least one of the first and second side walls and the ceiling includes a mounting hole; and
wherein one of the end walls and the ceiling includes a feature for engaging a strap.

19. The adapter defined in Claim 18, wherein the feature comprises a flange extending from each of the first and second end walls.

20. The adapter defined in Claim 18 or Claim 19, wherein the feature comprises a loop extending upwardly from the ceiling.

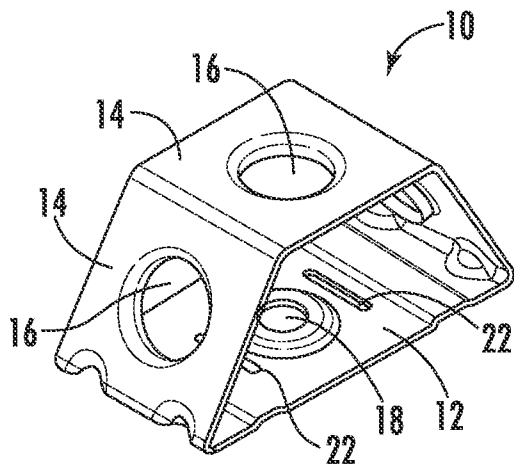

FIG. 1

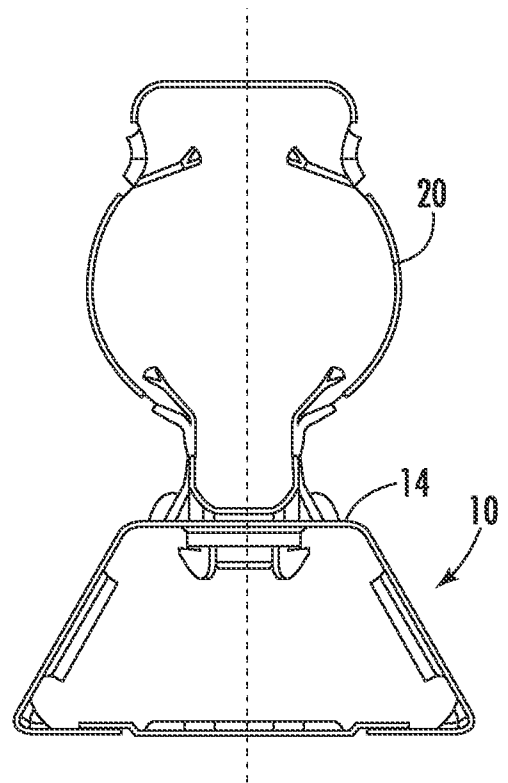

FIG. 2

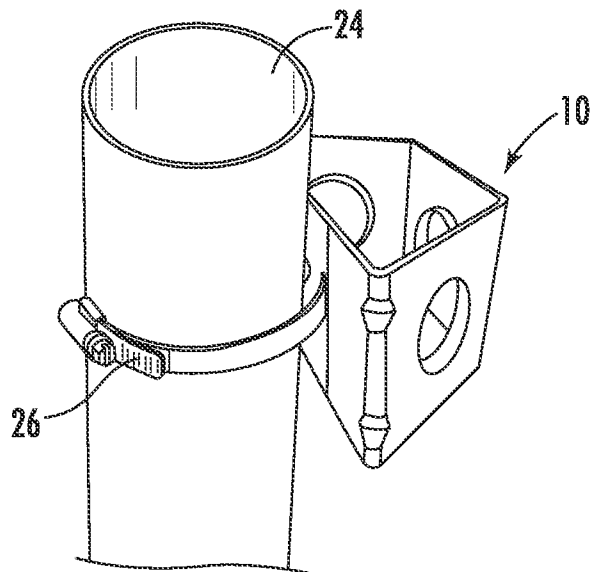

FIG. 3

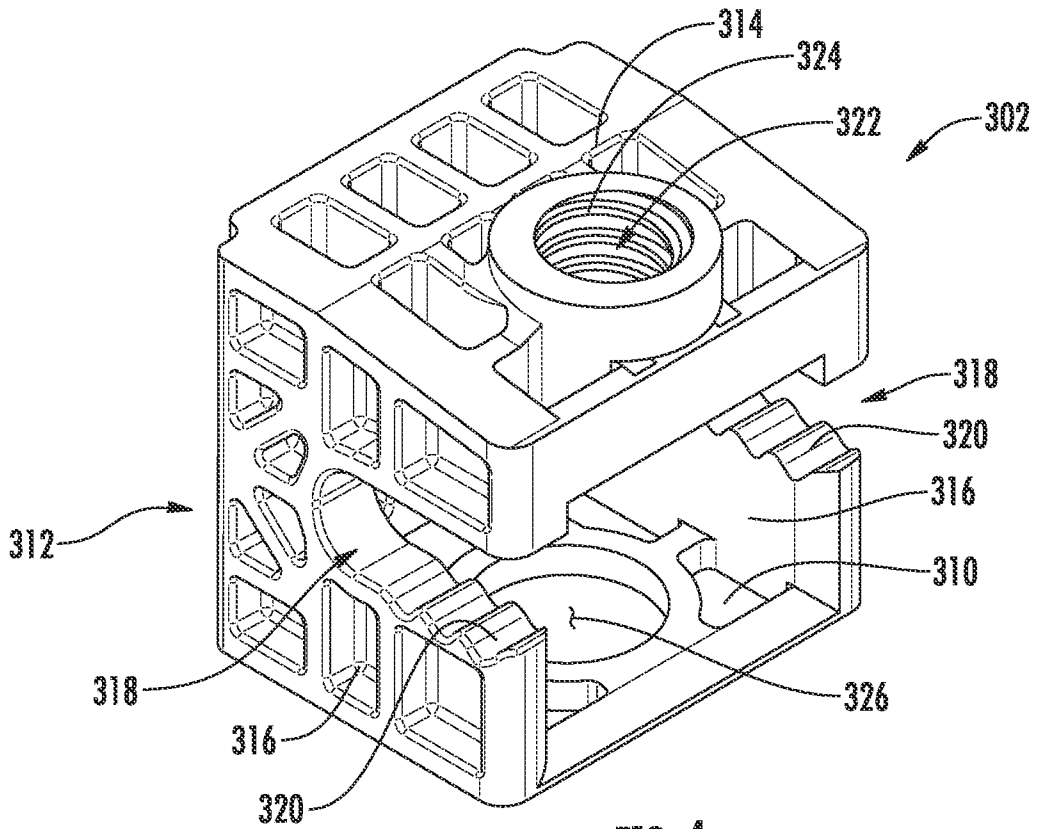

FIG. 4

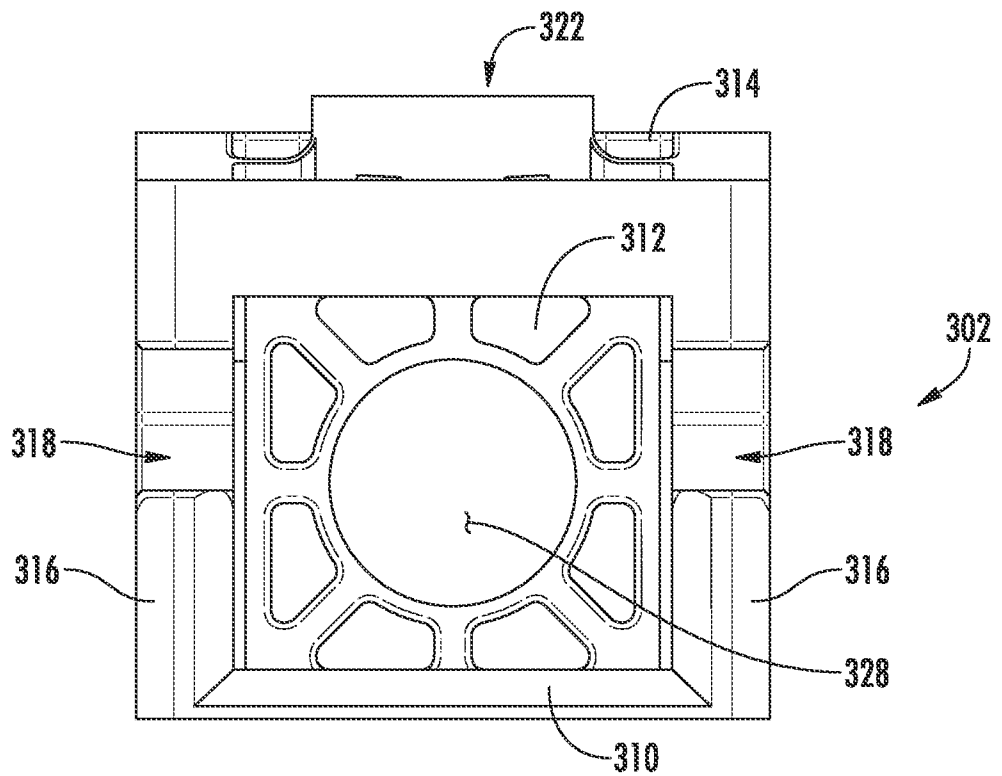

FIG. 5

3/12

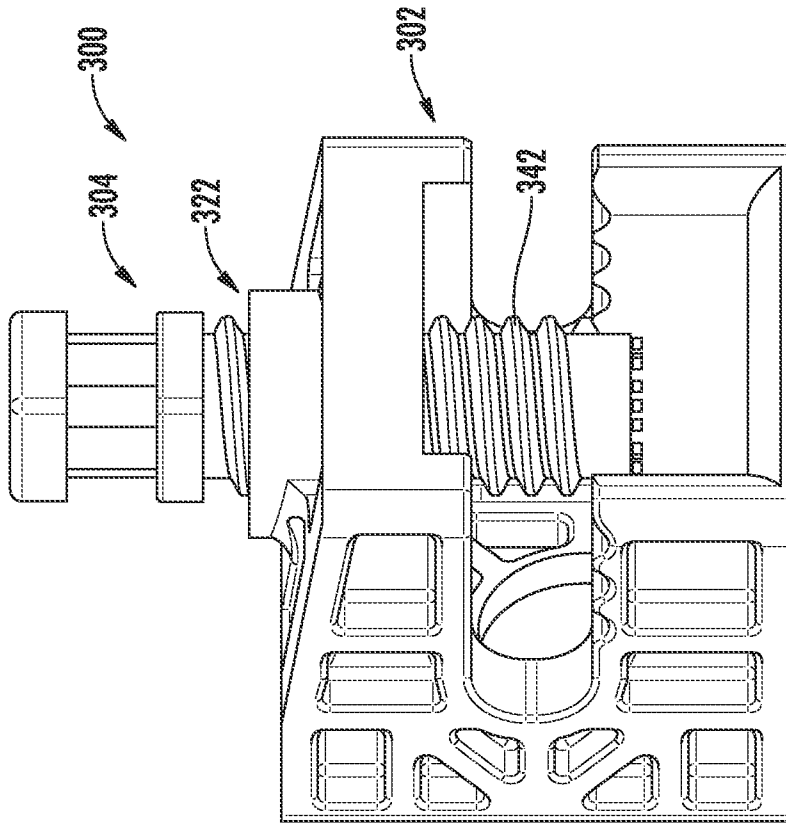

FIG. 6

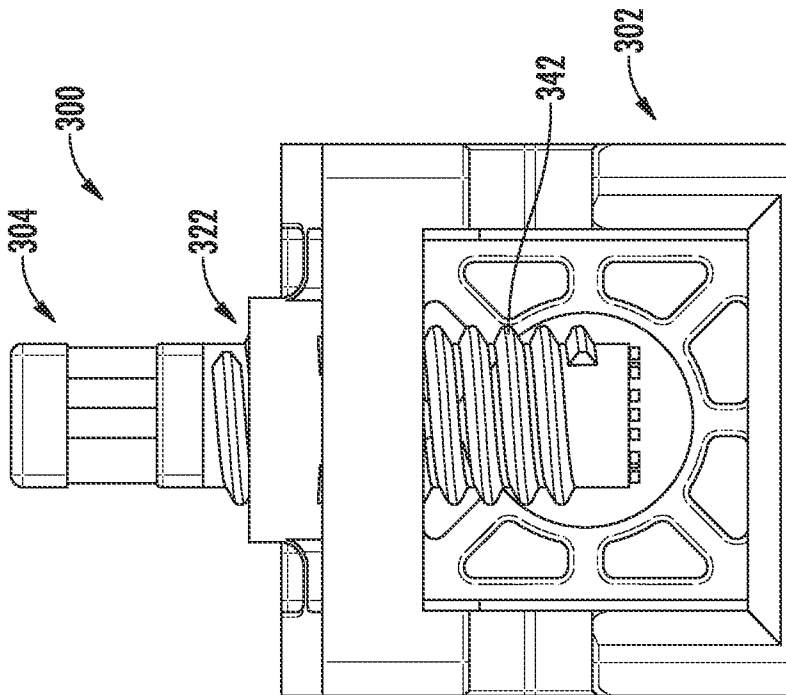

FIG. 7

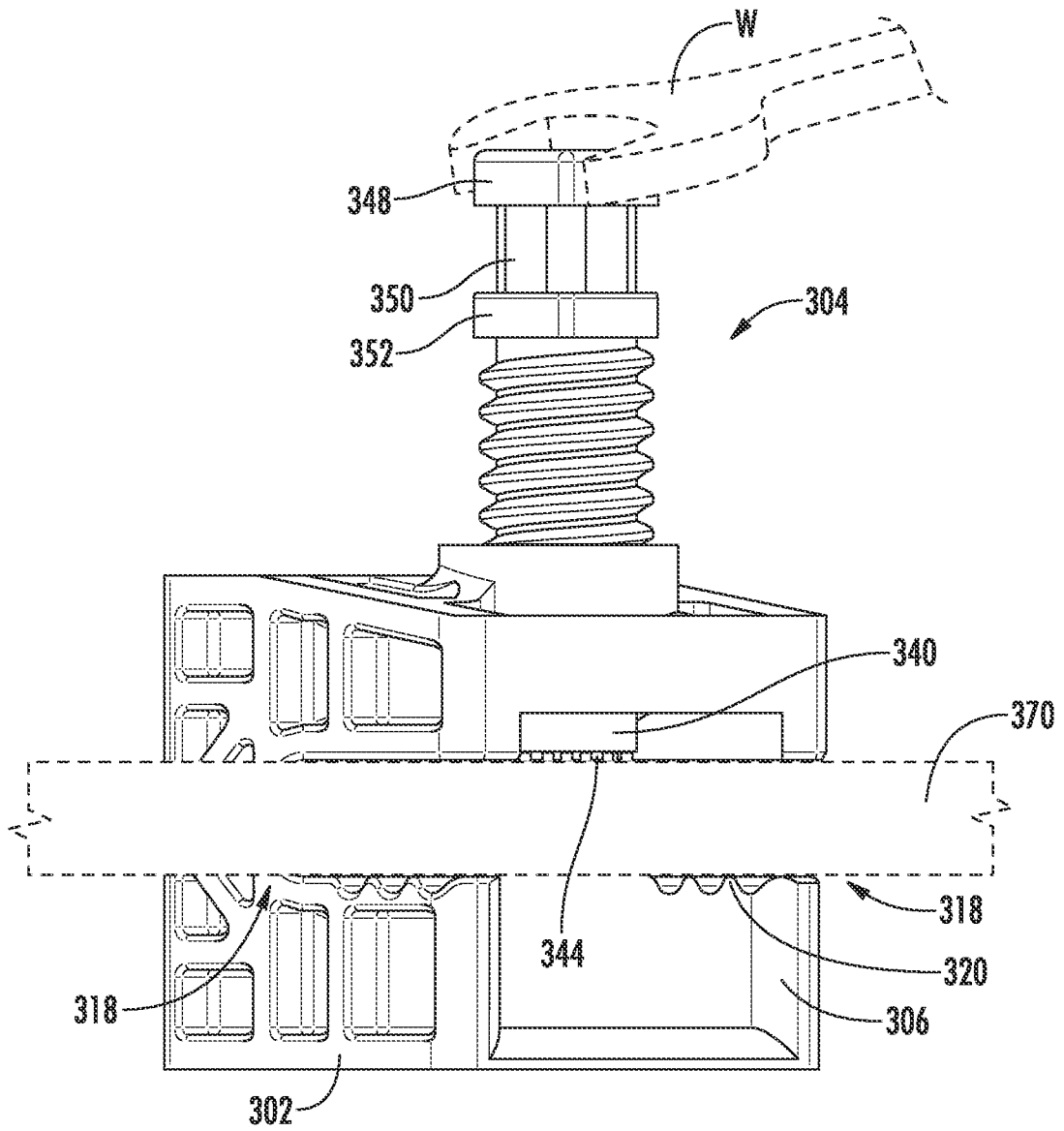

FIG. 8

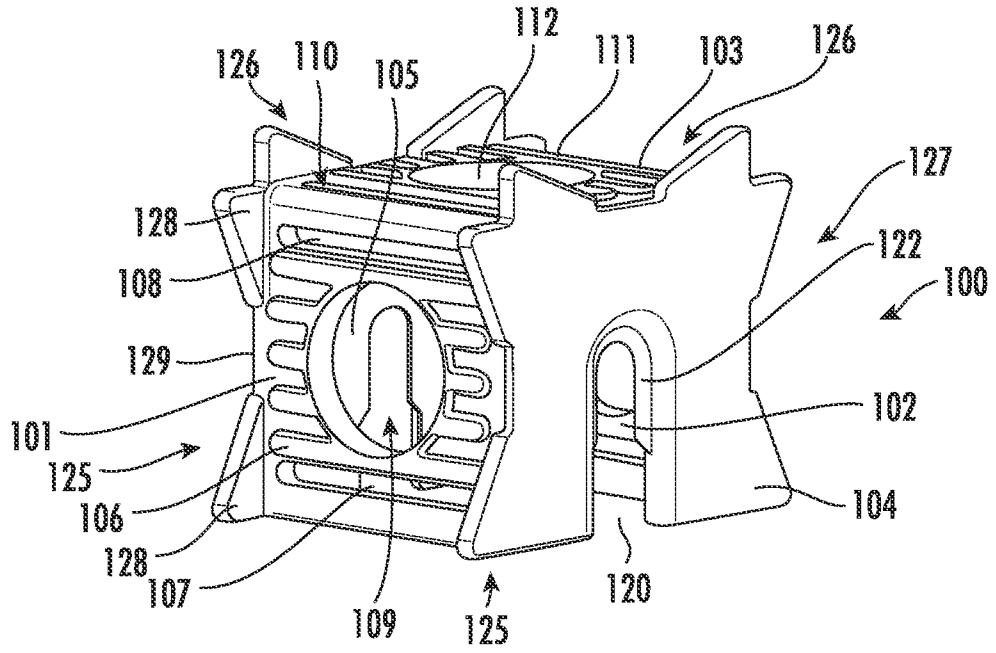

FIG. 9

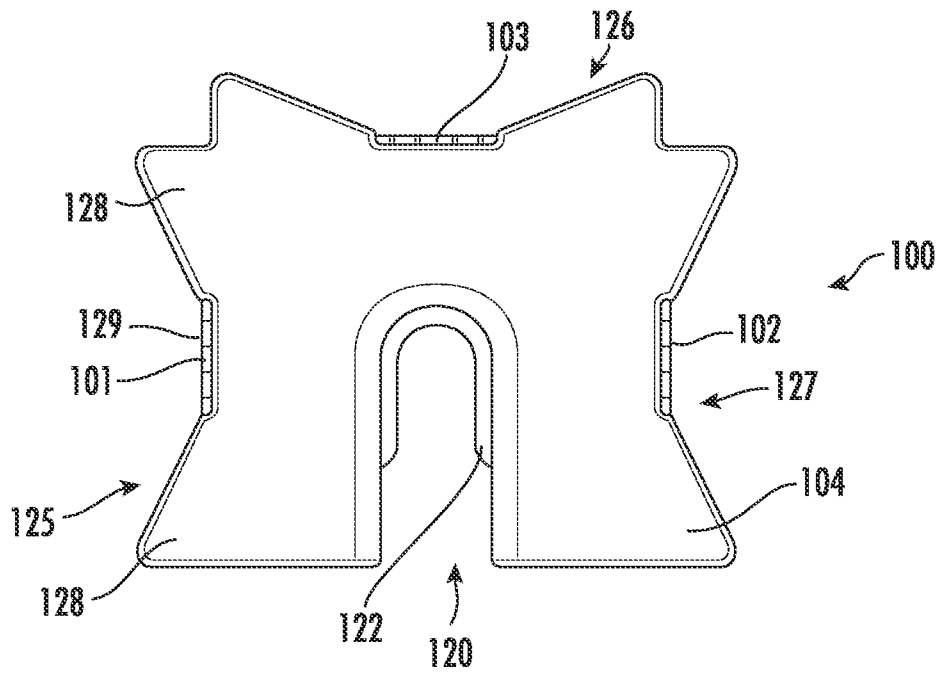

FIG. 10

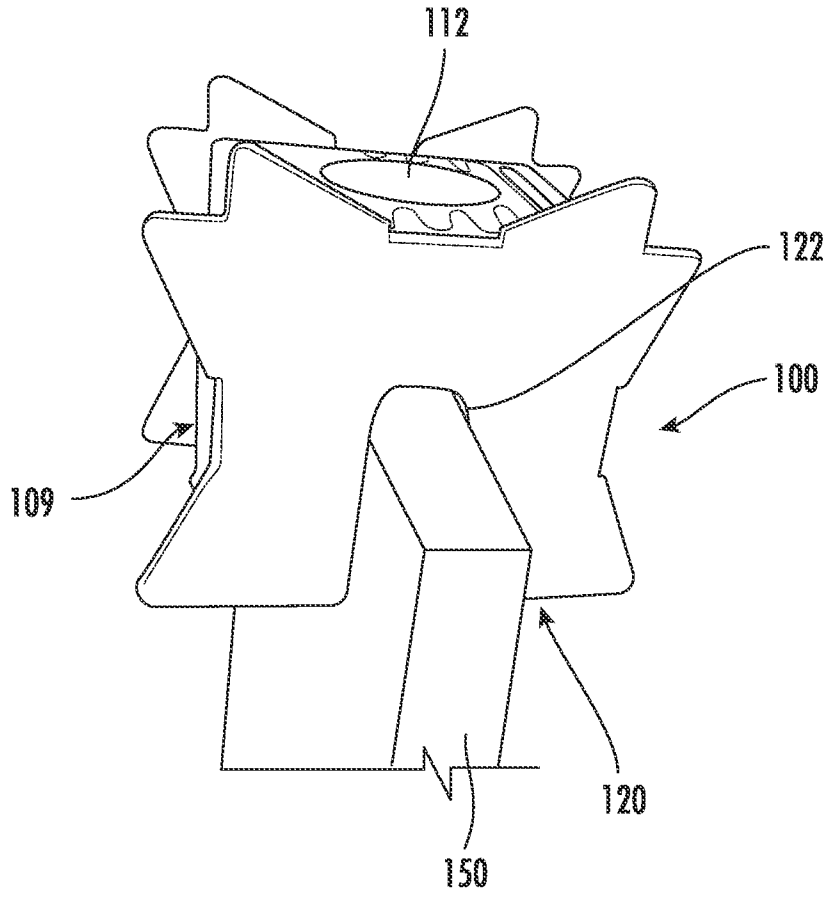

FIG. 11

7/12

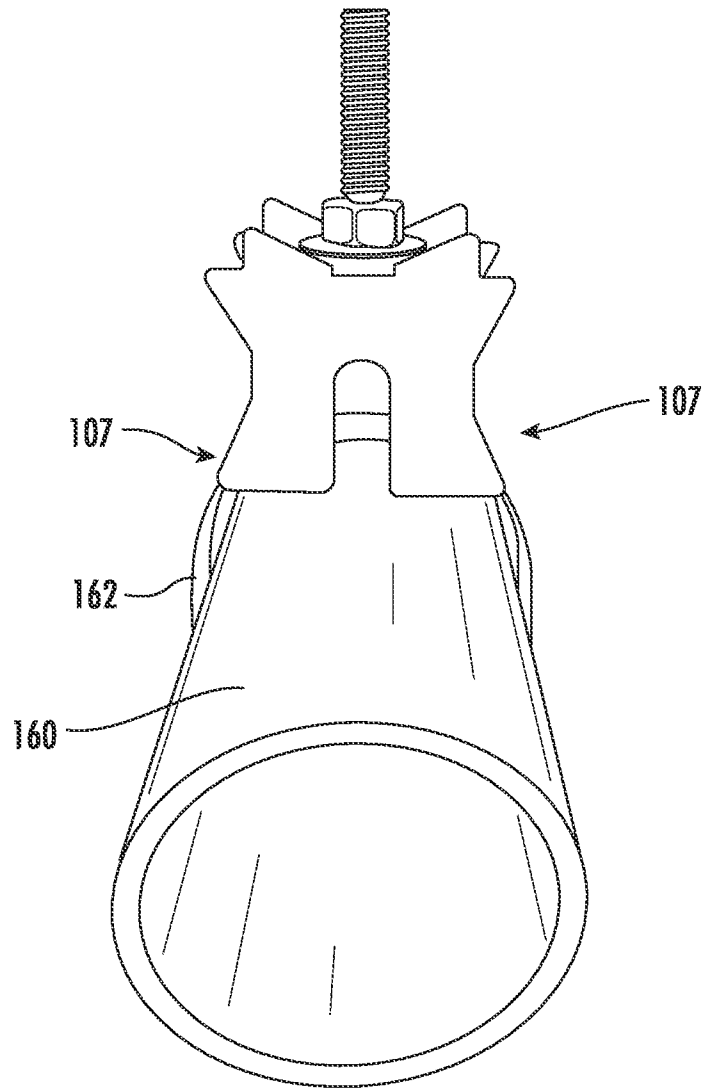

FIG. 12

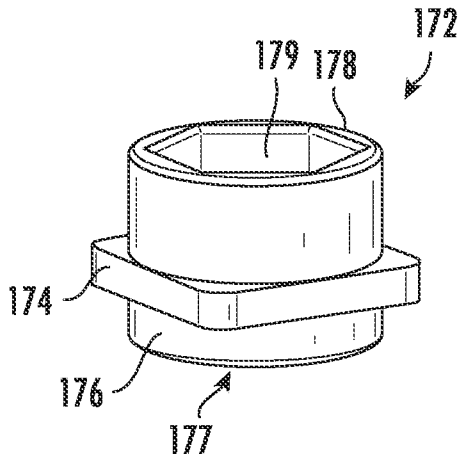

FIG. 13

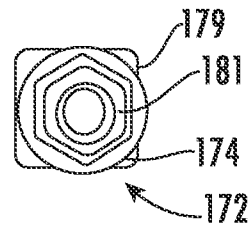

FIG. 14

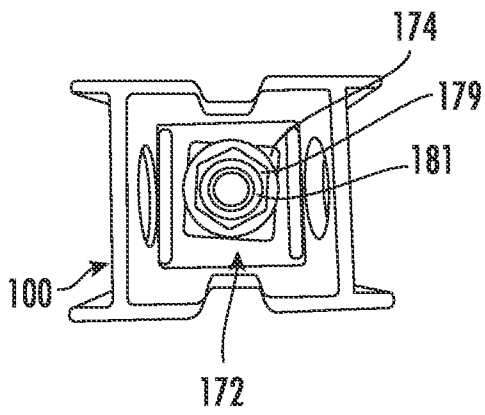

FIG. 15

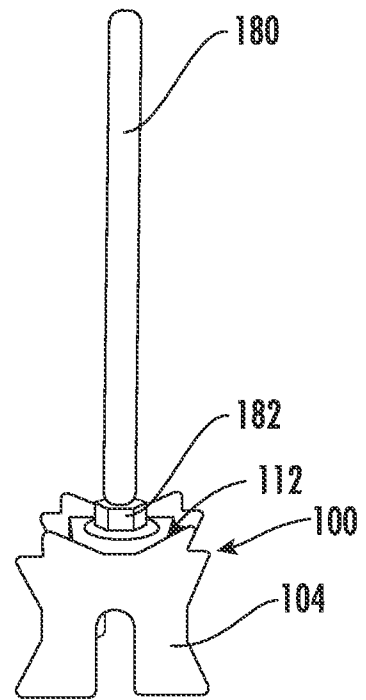

FIG. 16

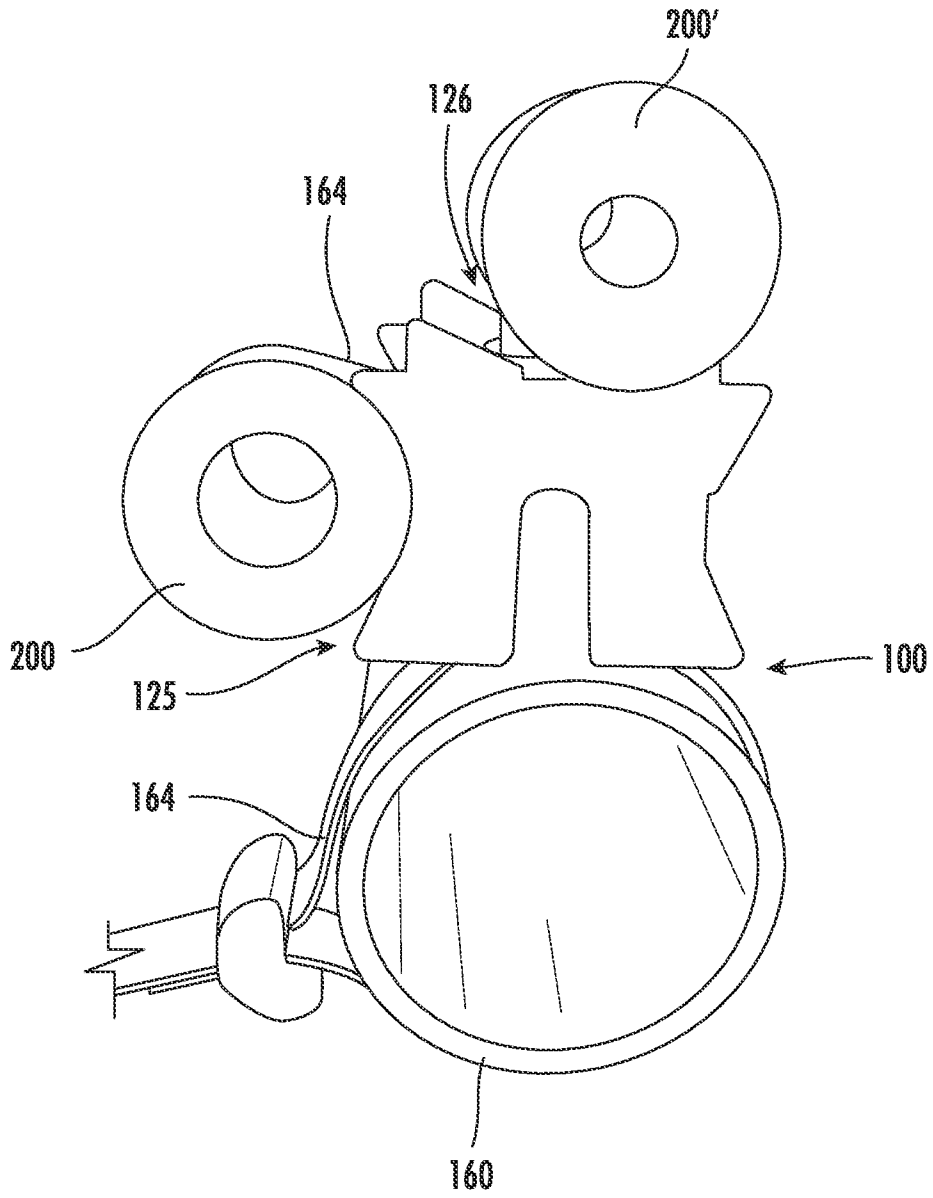

FIG. 17

10/12

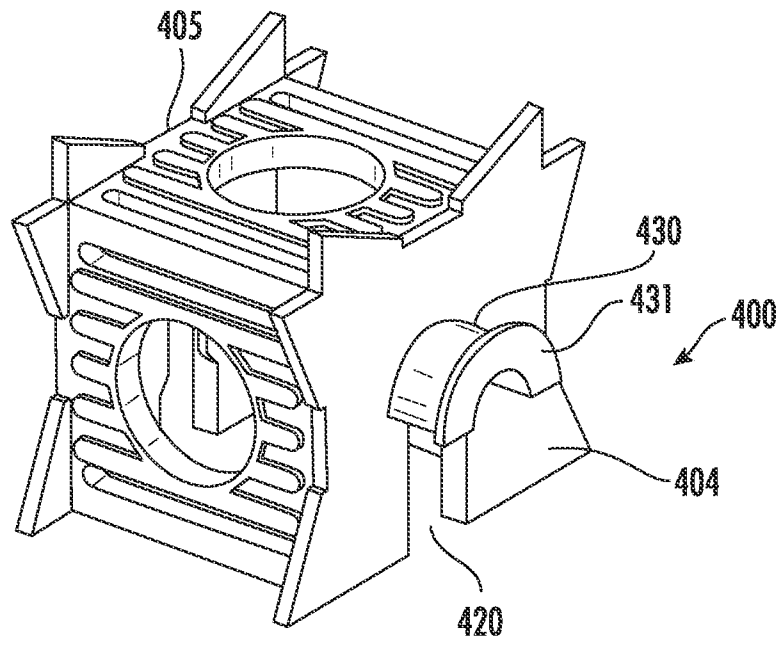

FIG. 18

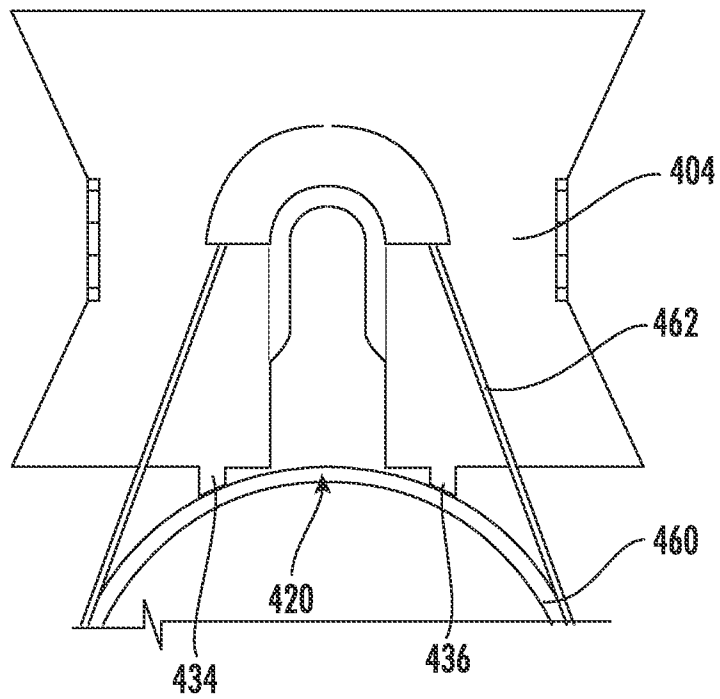

FIG. 19

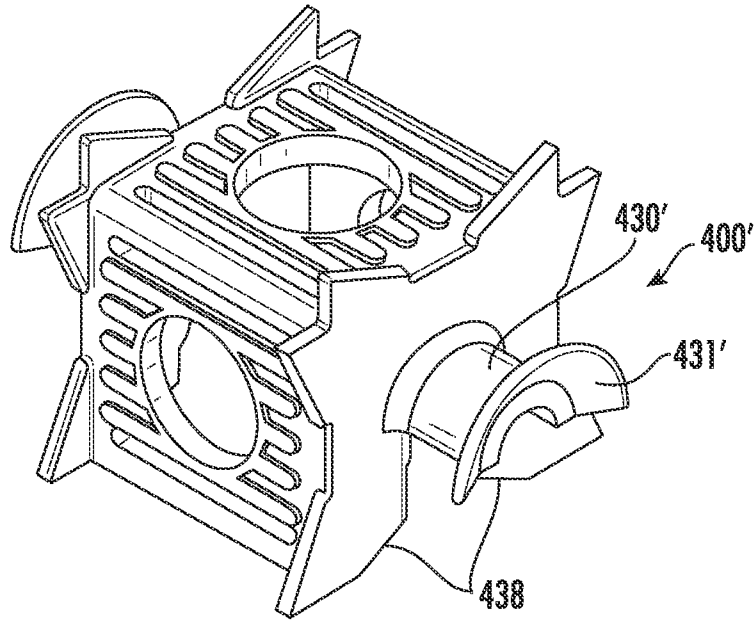

FIG. 20

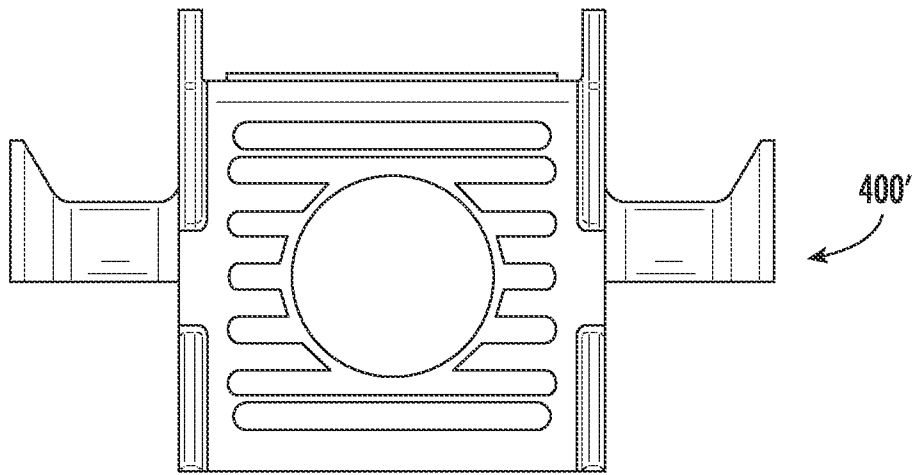

FIG. 21

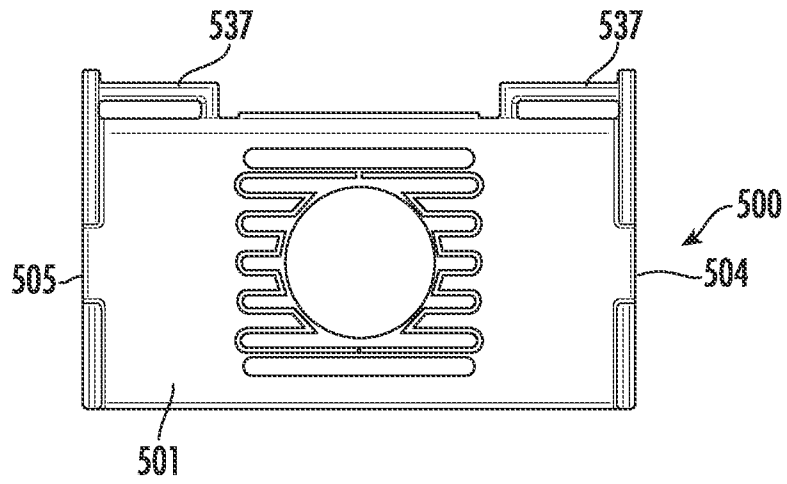

FIG. 22

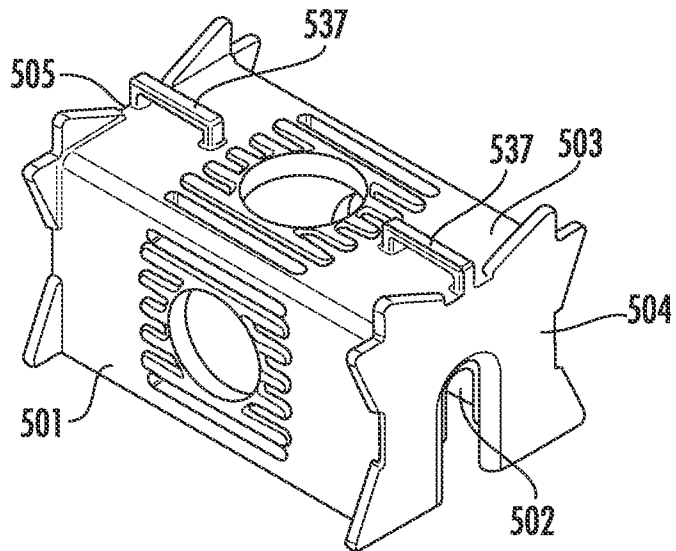

FIG. 23

INTERNATIONAL SEARCH REPORT

International application No.

PCT/US2022/019930

A. CLASSIFICATION OF SUBJECT MATTER		
F16B 2/08(2006.01)i; H02G 3/32(2006.01)i; F16L 3/00(2006.01)i; F16B 2/06(2006.01)i		
According to International Patent Classification (IPC) or to both national classification and IPC		
B. FIELDS SEARCHED		
Minimum documentation searched (classification system followed by classification symbols) F16B 2/08(2006.01); F16B 9/00(2006.01); F16G 11/02(2006.01); F16G 11/14(2006.01); F16L 3/00(2006.01); F16L 3/13(2006.01); H02G 1/04(2006.01); H02G 3/32(2006.01)		
Documentation searched other than minimum documentation to the extent that such documents are included in the fields searched Korean utility models and applications for utility models Japanese utility models and applications for utility models		
Electronic data base consulted during the international search (name of data base and, where practicable, search terms used) eKOMPASS(KIPO internal) & Keywords: adapter, cable hanger, mounting hole, open-ended recess, thin lip, slot		
C. DOCUMENTS CONSIDERED TO BE RELEVANT		
Category*	Citation of document, with indication, where appropriate, of the relevant passages	Relevant to claim No.
Y	US 2012-0124782 A1 (ELSNER et al.) 24 May 2012 (2012-05-24) paragraphs [0032]-[0035] and figures 1-4f	1-20
Y	US 2019-0390796 A1 (COMMSCOPE TECHNOLOGIES LLC.) 26 December 2019 (2019-12-26) paragraph [0006] and figures 1-3	1-20
Y	US 2020-0240489 A1 (ATTACHMOUNT, LLC.) 30 July 2020 (2020-07-30) paragraph [00026] and figures 1, 6	20
A	US 2020-0185899 A1 (MAXDAO LIMITED et al.) 11 June 2020 (2020-06-11) figure 1	1-20
A	US 2019-0081469 A1 (HUBBELL INCORPORATED) 14 March 2019 (2019-03-14) figures 1-10	1-20
<input type="checkbox"/> Further documents are listed in the continuation of Box C. <input checked="" type="checkbox"/> See patent family annex.		
* Special categories of cited documents: "A" document defining the general state of the art which is not considered to be of particular relevance "D" document cited by the applicant in the international application "E" earlier application or patent but published on or after the international filing date "L" document which may throw doubts on priority claim(s) or which is cited to establish the publication date of another citation or other special reason (as specified) "O" document referring to an oral disclosure, use, exhibition or other means "P" document published prior to the international filing date but later than the priority date claimed "T" later document published after the international filing date or priority date and not in conflict with the application but cited to understand the principle or theory underlying the invention "X" document of particular relevance; the claimed invention cannot be considered novel or cannot be considered to involve an inventive step when the document is taken alone "Y" document of particular relevance; the claimed invention cannot be considered to involve an inventive step when the document is combined with one or more other such documents, such combination being obvious to a person skilled in the art "&" document member of the same patent family		
Date of the actual completion of the international search 29 June 2022		Date of mailing of the international search report 29 June 2022
Name and mailing address of the ISA/KR Korean Intellectual Property Office 189 Cheongsa-ro, Seo-gu, Daejeon 35208, Republic of Korea Facsimile No. +82-42-481-8578		Authorized officer HWANG, Chan Yoon Telephone No. +82-42-481-3347

INTERNATIONAL SEARCH REPORT
Information on patent family members

International application No.

PCT/US2022/019930

Patent document cited in search report			Publication date (day/month/year)	Patent family member(s)			Publication date (day/month/year)
US	2012-0124782	A1	24 May 2012	DE	102008059360	A1	10 June 2010
				DE	102008059360	B4	09 October 2014
				EP	2371046	A2	05 October 2011
				EP	2371046	B1	10 January 2018
				US	9004417	B2	14 April 2015
				WO	2010-060634	A2	03 June 2010
				WO	2010-060634	A3	29 July 2010
US	2019-0390796	A1	26 December 2019	CN	109923745	A	21 June 2019
				CN	112838535	A	25 May 2021
				EP	3539190	A1	18 September 2019
				EP	3539190	A4	01 July 2020
				US	10415723	B2	17 September 2019
				US	2018-135778	A1	17 May 2018
				WO	2018-089154	A1	17 May 2018
US	2020-0240489	A1	30 July 2020	US	10837518	B2	17 November 2020
US	2020-0185899	A1	11 June 2020	CN	209767104	U	10 December 2019
				US	1133658	B2	28 September 2021
US	2019-0081469	A1	14 March 2019	WO	2019-051259	A1	14 March 2019