

No. 872,071

PATENTED NOV. 26, 1907.

J. W. LITTLE.
QUICK DROP MECHANISM.
APPLICATION FILED JUNE 15, 1905.

2 SHEETS—SHEET 1.

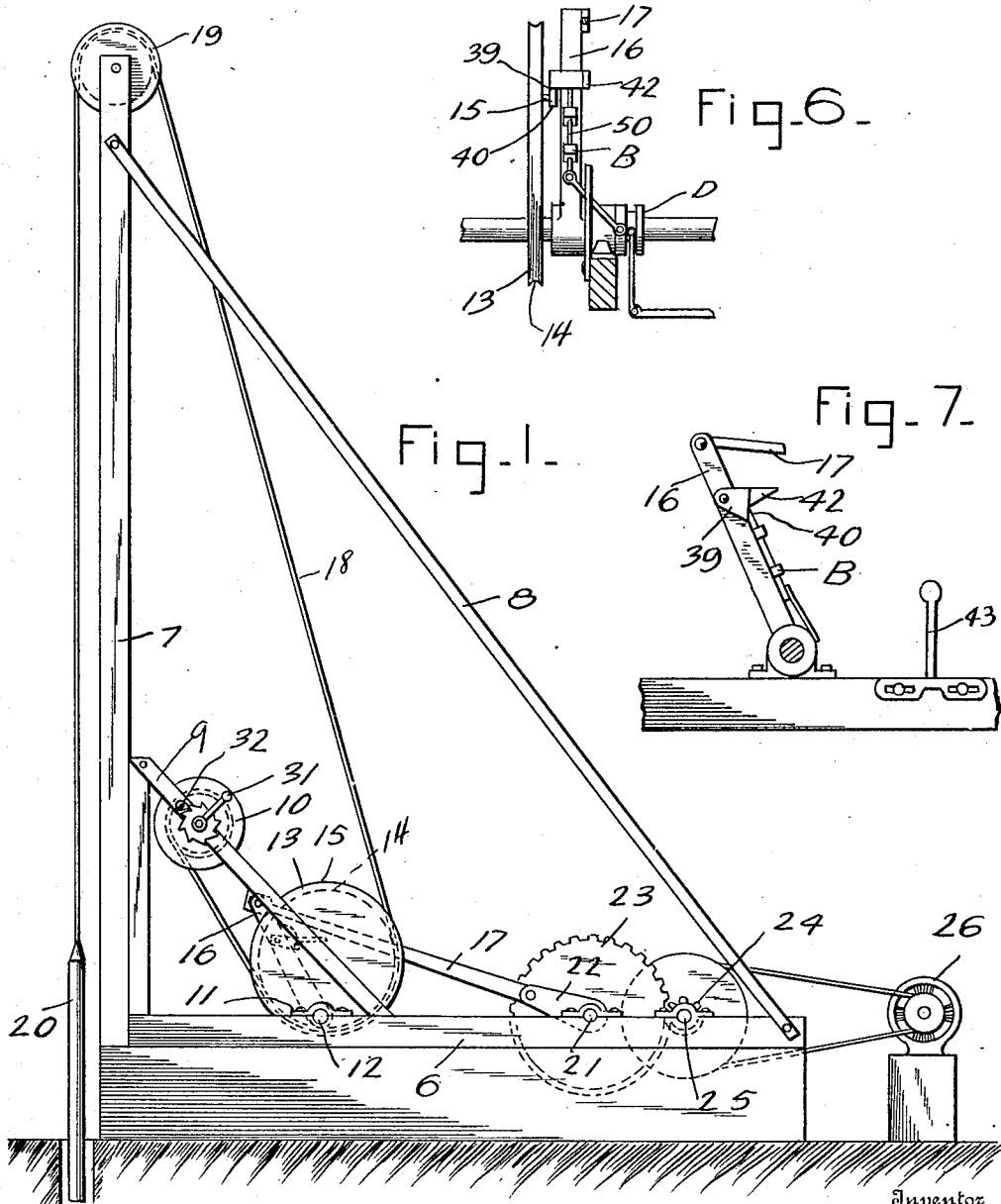

Inventor

J. W. Little

Witnesses

W. M. Rockwell
M. F. Miller

By

Charles Chandler

Attorneys

No. 872,071.

PATENTED NOV. 26, 1907.

J. W. LITTLE.
QUICK DROP MECHANISM.
APPLICATION FILED JUNE 15, 1905.

2 SHEETS—SHEET 2.

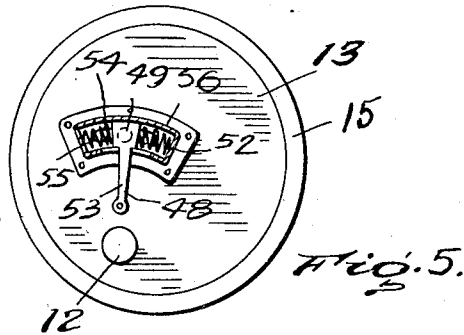
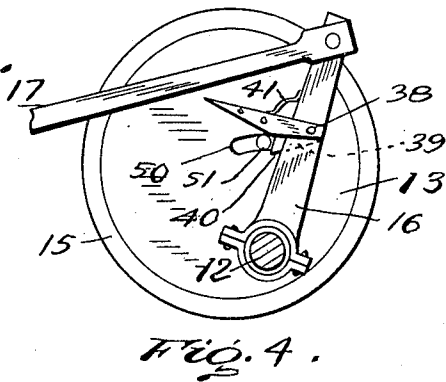
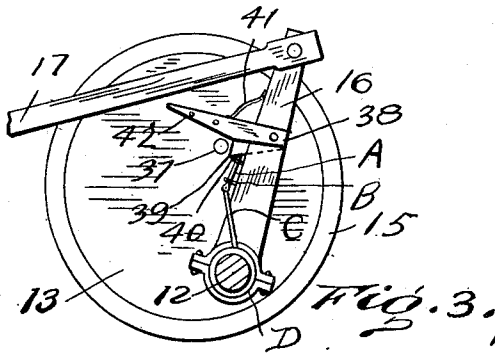
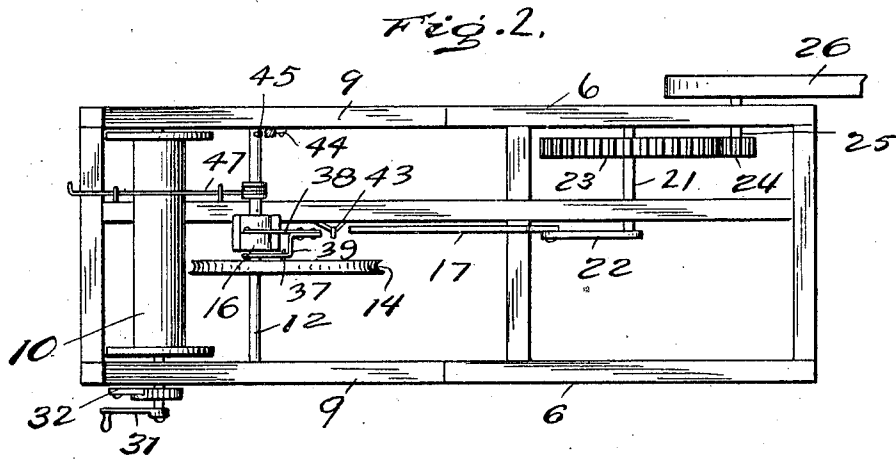

Witnesses

G. P. Thomas
E. M. Dalford

Inventor

J. W. Little

334 Chandler Chandler
Attorneys

UNITED STATES PATENT OFFICE.

JAMES W. LITTLE, OF DEERTRAIL, WASHINGTON.

QUICK-DROP MECHANISM.

No. 872,071.

Specification of Letters Patent.

Patented Nov. 26, 1907.

Application filed June 15, 1905. Serial No. 265,335.

To all whom it may concern:

Be it known that I, JAMES W. LITTLE, a citizen of the United States, residing at Deertrail, in the county of Stevens, State of Washington, have invented certain new and useful Improvements in Quick-Drop Mechanism; and I do hereby declare the following to be a full, clear, and exact description of the invention, such as will enable others skilled in the art to which it appertains to make and use the same.

This invention relates to boring machines and more particularly to quick-drop mechanisms therefor, and has for its object to provide a mechanism of this kind arranged to permit the bit of the mechanism to drop under its own weight when raised to a predetermined point, another object being to provide a mechanism including a novel arrangement of parts, and one which will not be likely to become deranged.

Other objects and advantages will be apparent from the following description, and it will be understood that modifications of the specific construction shown may be made, and any suitable materials may be used without departing from the spirit of the invention.

In the drawings forming a portion of this specification and in which like numerals of reference indicate similar parts in the several views, Figure 1 is a side elevation of the complete mechanism. Fig. 2 is a top plan view of the structure shown in Fig. 1. Fig. 3 is an enlarged detail view showing the disk and operating arm in side elevation. Fig. 4 is a view similar to Fig. 3 showing the disk provided with a modified form of pin. Fig. 5 is a view of the opposite side of the disk shown in Fig. 4, the spring casing being broken away. Fig. 6 is an end elevation of a connection between the pulley and a pitman for operating the same, such connection to be hereinafter specifically described, and Fig. 7 is a side elevation thereof.

Referring now to the drawings, there are shown parallel sills 6 having uprights 7 at their forward ends which are braced from their upper ends to the rearward ends of the sills by means of tie rods 8. Secured to the sills 6, adjacent to their forward ends are frames 9, between which there is journaled a winding drum 10. Mounted for oscillation in bearings 11 upon the sills 6 is a shaft 12 which is disposed below and slightly rearwardly of the drum 10, and eccentrically

mounted upon the shaft 12 is a disk 13 having a peripheral groove 14, formed in a peripheral wear strap 15. Secured to the drum 10 is a bit cable 18 which is engaged in the groove 14 of the disk 13 and extends upwardly rearwardly of the disk and is engaged over a sheave 19 which is revolubly mounted between the upper ends of the uprights 7, the cable descending forwardly of the sheave, and having the bit stock 20 secured to its free end. Journaled between the sills rearwardly of the shaft 12 is a shaft 21 having a crank 22 thereon with which is pivotally connected the end of a pitman 17, the other end of said pitman being operatively connected with the shaft 12, so that when said shaft is oscillated, the disk 13 will be oscillated therewith, the eccentricity of this disk causing the bit stock 20 to rise and fall, as will be readily understood. Mounted upon the shaft 21 is a gear wheel 23 with which is meshed a pinion 24 carried by a shaft 25 which is connected with a source of power 26 and is revolved thereby. The drum 10 is provided with a handle 31 by which it may be revolved to vary the length of the cable 18 and the drum 10 is provided with a suitable detent 32.

The shaft 12 has an upwardly extending rock arm 16 loosely mounted thereupon, this rock arm being connected with the crank 22 by the pitman 17, the arrangement being such that the arm 16 is oscillated as the crank revolves. A laterally extending pin 37 is mounted upon a face of the eccentric disk 13 and extends in the direction of the arm 16 and pivoted to this arm for vertical movement there is a latch 38 having a portion 39 lying in the direction of the disk 13 as shown, to bring the shoulder 40 carried by this portion into the vertical plane occupied by the pin 37, and the vertical movement of the latch is such that this shoulder may be brought into and out of the arc through which the pin 37 travels when the disk 13 is moved, the latch, when in this position, being adapted for engagement of its shoulder with the pin through movement of the arm 16 upon the shaft. A spring 41 holds the latch yieldably in position for engagement of its shoulder with the pin.

In operation, it being assumed that the shoulder 40 is engaged with the pin 37, the crank 22 is revolved to move the arm 16 rearwardly and the eccentric disk is also moved to raise the bit stock. When the stock has been raised to the upward limit of its movement, a rearwardly extending beveled por-

tion 42 of the latch engages the upper end of an upright 43 by which the latch is raised to release the pin 37 and the disk 13 is returned to its original position by the weight of the bit stock, after which further rotation of the crank 22 moves the arm 16 forwardly to bring its latch again into position for engagement of the pin 37. Continued rotation of the crank 22 results in repetition of the just described operation, as will be readily understood, and the upright 43 is movable toward and away from the arm 16 to vary the point at which the latch 38 releases the pin 37, it being thus possible to adjust the movement of the bit stock 20. A resilient bumper 44 is secured to one of the sills in position to receive thereagainst an arm 45 carried by the shaft 12, thus limiting the return movement of the disk 13 when released. A lever mechanism 47 is provided and is connected with the latch 38 for movement of the latch into inoperative position to release the pin 37 whenever it may be desired to do so. This lever mechanism consists of a rod A which is mounted in guides B upon the arm 16, this rod extending vertically and lying below the latch 38 and in position to engage this latch with its upper end when the rod is moved upwardly to move the latch upon its pivot. The lower end of the rod A is pivoted to a slanting rod C, the latter being pivoted in turn to a collar D slidably mounted upon the shaft 12. It will thus be apparent that when the collar D is moved in the direction of the operative movement of the arm 16, the rod A will be moved upwardly to raise the latch 38 and disengage it from the pin 37.

In Figs. 4 and 5, there is shown a form in which the pin 37 is replaced by a member 48, which is pivoted upon the face of the disk 13 and which has an end 49 for engagement by the latch 38. An arcuate slot 50 is formed through the disk 13 and lies concentrically with the pivot point of the member 48, and a pin 51 is carried by the head y of this member and extends through the slot, this pin lying in position for engagement by the shoulder 40 of the latch 38, the pin projecting beyond the opposite surface of the disk from the member as shown. A casing 52 is secured to the side of the disk to which the member 48 is

pivoted and is of arcuate form, this casing lying concentric with the pivot point of the member 48 and receiving within itself the head 49 of the member, the stem 53 of the member at one end of which it is pivoted, extending through a slot 54 formed in the concave surface of the casing and disposed within the casing between the ends thereof and the head 49 of the member, there are helical springs 55 which hold the member 48 yieldably against movement upon its pivot, so as to lessen the sudden strain upon the cable when the member is engaged by the latch 38, and this arrangement of springs also reduced the strain incident to sudden stopping of the machine should the bit become caught in the well.

What is claimed is:

1. A machine of the class described comprising a frame, a rock shaft in the frame, an arm carried by the rock shaft, a disk eccentrically mounted upon the rock shaft for oscillation and arranged for engagement of a cable therearound, a projection carried by the disk, a latch carried by the arm and arranged for engagement of the projection to move the disk with the rock shaft in one direction, means for disengaging the latch from the projection at a predetermined point of rotation of the disk, and means for rocking the shaft.

2. A machine of the class described comprising a frame, a rock shaft in the frame, an arm carried by the rock shaft, a disk eccentrically mounted upon the rock shaft for oscillation, a projection carried by the disk, a latch carried by the arm and arranged for engagement of the projection to move the disk with the rock shaft in one direction to raise the bit, said projection being movable with respect to the disk, means for holding the projection yieldably against such movement, and means for disengaging the latch from the projection at a predetermined point in the rotation of the disk.

In testimony whereof, I affix my signature, in presence of two witnesses.

JAMES W. LITTLE.

Witnesses:

DANIEL R. SNYDER,
W. P. DAVIS.