



US011550247B2

(12) **United States Patent**
Kikuchi

(10) **Patent No.:** **US 11,550,247 B2**

(45) **Date of Patent:** **Jan. 10, 2023**

(54) **HEAT REFLECTION USING REFLECTOR IN FIXING DEVICE AND IMAGE FORMING APPARATUS**

(56) **References Cited**

U.S. PATENT DOCUMENTS

(71) Applicant: **TOSHIBA TEC KABUSHIKI KAISHA**, Tokyo (JP)

5,528,351 A 6/1996 Tsuji
9,229,392 B2 1/2016 Nakano
(Continued)

(72) Inventor: **Kazuhiko Kikuchi**, Yokohama Kanagawa (JP)

FOREIGN PATENT DOCUMENTS

(73) Assignee: **TOSHIBA TEC KABUSHIKI KAISHA**, Tokyo (JP)

CN 102193433 A 9/2011
JP H08-115003 A 5/1996
(Continued)

(*) Notice: Subject to any disclaimer, the term of this patent is extended or adjusted under 35 U.S.C. 154(b) by 0 days.

OTHER PUBLICATIONS

(21) Appl. No.: **17/699,882**

Chinese First Office Action dated Mar. 31, 2022, mailed in corresponding Chinese Patent Application No. 201811554171.3, 16 pages (with Translation).

(22) Filed: **Mar. 21, 2022**

(Continued)

(65) **Prior Publication Data**

US 2022/0206418 A1 Jun. 30, 2022

Primary Examiner — Susan S Lee

Related U.S. Application Data

(74) *Attorney, Agent, or Firm* — Kim & Stewart LLP

(63) Continuation of application No. 17/210,877, filed on Mar. 24, 2021, now Pat. No. 11,314,187, which is a (Continued)

(57) **ABSTRACT**

(30) **Foreign Application Priority Data**

Jan. 11, 2018 (JP) JP2018-002878

A fixing device includes a belt, a roller, a heater, and a reflector. The belt is rotatable in a rotational direction. The roller is positioned to be in contact with an outer peripheral surface of the belt so as to form a nip between the roller and the belt. The heater is disposed within an inner circumference of the belt. The reflector is configured to reflect heat generated by the heater toward an inner surface of the belt. The reflector includes a first portion that is in contact with the belt at a first region downstream with respect to the nip in the rotational direction. The first portion causes a curvature of the belt at the first region to be greater than the curvature of the belt at regions of the belt adjacent to the first region.

(51) **Int. Cl.**
G03G 15/20 (2006.01)

(52) **U.S. Cl.**
CPC **G03G 15/2039** (2013.01); **G03G 15/2007** (2013.01); **G03G 15/2028** (2013.01); **G03G 15/2053** (2013.01)

(58) **Field of Classification Search**
CPC G03G 15/2039; G03G 15/2007; G03G 15/2028; G03G 15/2053; G03G 15/2017; G03G 15/5045

See application file for complete search history.

20 Claims, 3 Drawing Sheets

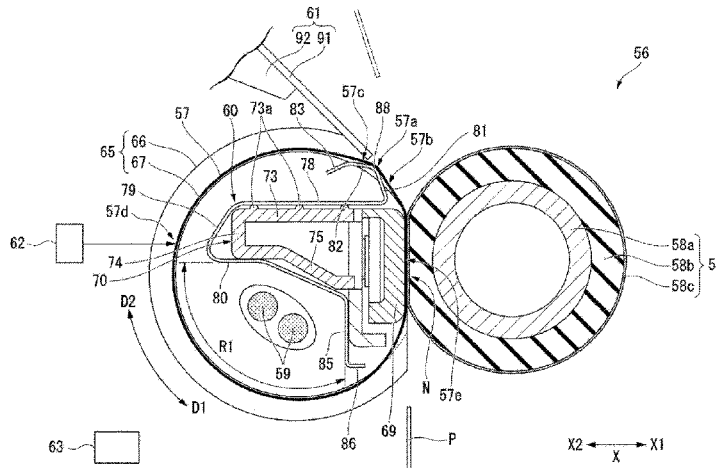

Related U.S. Application Data

continuation of application No. 16/901,408, filed on Jun. 15, 2020, now Pat. No. 10,983,462, which is a continuation of application No. 16/574,615, filed on Sep. 18, 2019, now Pat. No. 10,705,460, which is a continuation of application No. 16/111,399, filed on Aug. 24, 2018, now Pat. No. 10,459,380.

(56)

References Cited

U.S. PATENT DOCUMENTS

9,523,949	B1	12/2016	Kikuchi	
10,459,380	B2	10/2019	Kikuchi	
2008/0292372	A1	11/2008	Han	
2011/0058864	A1*	3/2011	Fujimoto G03G 15/2039 399/329
2011/0217096	A1	9/2011	Kikuchi et al.	
2013/0251390	A1	9/2013	Ishii et al.	
2015/0063882	A1	3/2015	Nakano	
2015/0063883	A1	3/2015	Nakano	

FOREIGN PATENT DOCUMENTS

JP	2013-178511	A	9/2013
JP	2015-045712	A	3/2015
JP	2016-080831	A	5/2016

OTHER PUBLICATIONS

Japanese Notice of Reasons for Refusal dated Jul. 27, 2021, in corresponding Japanese Patent Application No. 2018-002878, 6 pages (with Translation).

* cited by examiner

FIG. 2

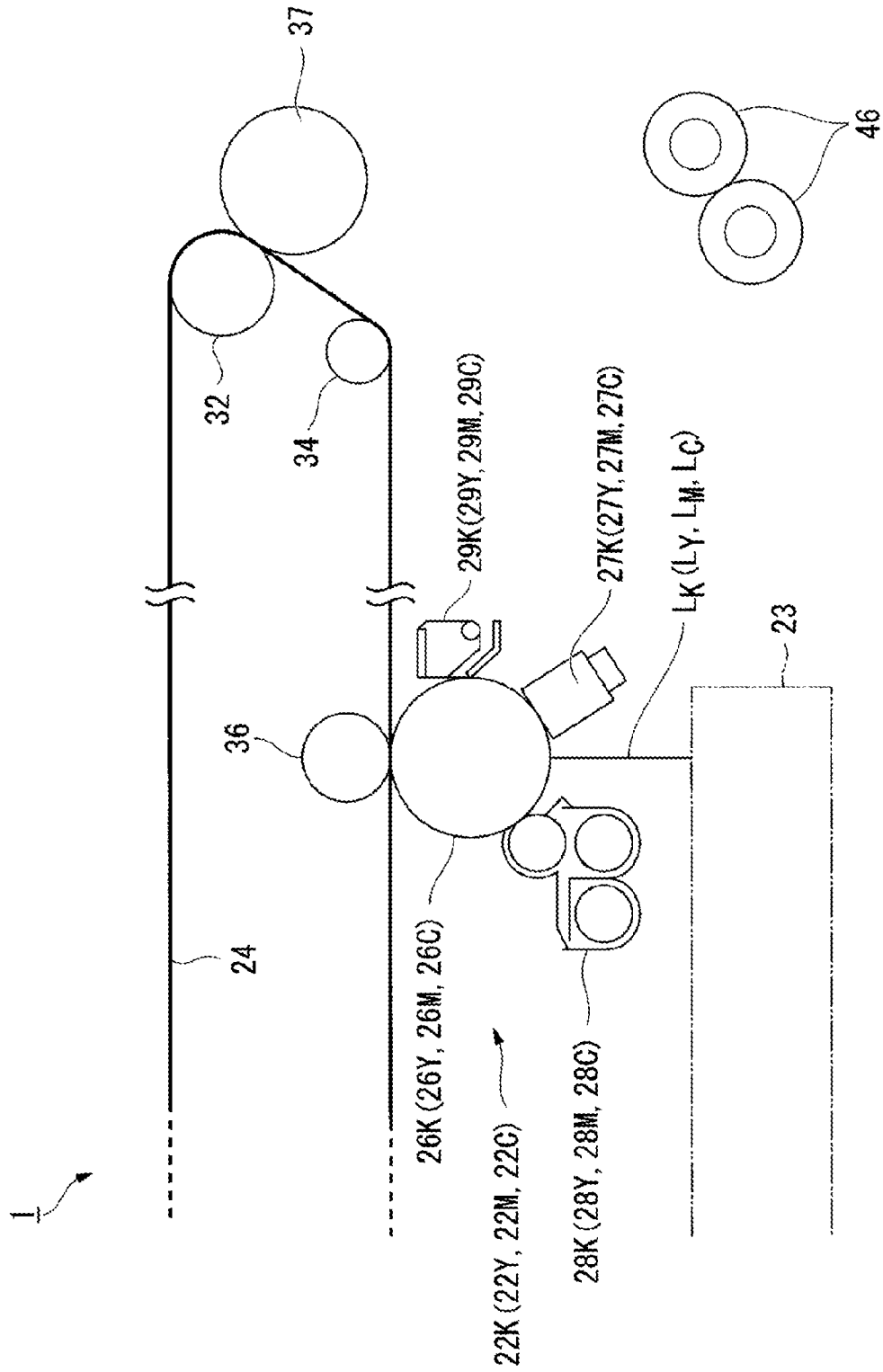

HEAT REFLECTION USING REFLECTOR IN FIXING DEVICE AND IMAGE FORMING APPARATUS

CROSS-REFERENCE TO RELATED APPLICATIONS

This application is a continuation of U.S. patent application Ser. No. 17/210,877, filed on Mar. 24, 2021, which is a continuation of U.S. patent application Ser. No. 16/901,408, filed on Jun. 15, 2020, now U.S. Pat. No. 10,983,462, issued on Apr. 20, 2021, which is a continuation of U.S. patent application Ser. No. 16/574,615, filed on Sep. 18, 2019, now U.S. Pat. No. 10,705,460, issued on Jul. 7, 2020, which is a continuation of U.S. patent application Ser. No. 16/111,399, filed on Aug. 24, 2018, now U.S. Pat. No. 10,459,380, issued on Oct. 29, 2019, which is based upon and claims the benefit of priority from Japanese Patent Application No. 2018-002878, filed on Jan. 11, 2018, the entire contents of each of which are incorporated herein by reference.

FIELD

Embodiments described herein relate generally to a fixing device and an image forming apparatus.

BACKGROUND

A fixing device of the related art includes a fixing belt, a pressure roller, a heating unit, and a reflecting unit.

The fixing belt is formed in a cylindrical shape. The roller presses against the fixing belt so as to form a fixing nip. The heating unit radiates heat. The heating unit is surrounded by the fixing belt. The reflecting unit is also surrounded by the fixing belt. The reflecting unit reflects heat generated from the heating unit.

Paper is conveyed to the fixing nip between the fixing belt and the roller. The paper is heated through the fixing belt due to heat, which is generated from the heating unit and is reflected from the reflecting unit as needed. Accordingly, a toner transferred to the paper is fixed to the paper.

However, the fixing device having such a configuration may be used for an image forming apparatus for high-speed printing which requires relatively high electric power of the heating unit. In this case, heat transfer efficiency from the heating unit to the belt may decrease as a result of the temperature of the reflecting member becoming too high.

BRIEF DESCRIPTION OF THE DRAWINGS

FIG. 1 is a sectional view illustrating a configuration example of an image forming apparatus of an embodiment.

FIG. 2 is a sectional view in which a part of the image forming apparatus of the embodiment is enlarged.

FIG. 3 is a sectional view illustrating a fixing unit in the image forming apparatus of the embodiment.

DETAILED DESCRIPTION

Embodiments provide a fixing device capable of improving heat transfer efficiency from a heating unit to a belt, and an image forming apparatus comprising the fixing device.

In general, according to one embodiment, there is provided a fixing device including a belt having a cylindrical shape, a roller, a heater, and a reflector. The roller is positioned to be in contact with an outer peripheral surface of the belt so as to form a nip between the roller and the belt.

The heater is disposed within an inner circumference the belt. The reflector is disposed within the inner circumference the belt and in contact with the belt and configured to reflect heat generated by the heater toward an inner surface of the belt.

Hereinafter, the fixing device and the image forming apparatus of the embodiment will be described with reference to drawings.

An image forming apparatus of the embodiment is illustrated in FIG. 1 (as image forming apparatus 1) and may be, for example, a multi-function peripheral (MFP), printer, copy machine, and the like. Hereinafter, an example of a case in which the image forming apparatus is the MFP will be described.

A configuration of the image forming apparatus of the embodiment is not particularly limited. For example, the image forming apparatus 1 includes a main body 11. A document platen 12 including transparent glass is provided on an upper portion of the main body 11. An automatic document feeder (ADF) 13 is provided on the document platen 12. An operation unit 14 is provided on the upper portion of the main body 11. The operation unit 14 includes an operation panel 14a including various keys and a touch panel display 14b.

A scanner unit 15 is provided on a lower portion of the ADF 13. The scanner unit 15 reads a document conveyed by the ADF 13 or a document placed on the document platen 12. The scanner unit 15 generates image data of the document. For example, the scanner unit 15 includes an image sensor 16. For example, the image sensor 16 may be a contact type image sensor.

The image sensor 16 moves parallel to a surface of the document platen 12 when reading an image of a document placed on the document platen 12.

The main body 11 includes a printer unit 17 at the center in a height direction. The main body 11 includes paper feeding cassettes 18A and 18B on a lower portion thereof and a manual paper feeding unit 18C.

The paper feeding cassettes 18A and 18B are disposed inside the main body 11. The paper feeding cassettes 18A and 18B are disposed to be overlapped with each other in this order from an upper side to a lower side.

The manual paper feeding unit 18C protrudes from a side of the main body 11 down below a reverse conveyance path 52 to be described later.

The paper feeding cassettes 18A and 18B and the manual paper feeding unit 18C accommodate sheets of paper P having various sizes. The paper feeding cassettes 18A and 18B and the manual paper feeding unit 18C accommodate the sheets of paper P having different sizes so that the center axis of the sheets in the conveying direction are the same even though the sheets of different sizes are accommodated therein.

The paper feeding cassette 18A (18B) includes paper feeding mechanisms 19A (19B). Also, the paper feeding cassette 18A (18B) including the paper feeding mechanisms 19A (19B) means both the paper feeding cassette 18A including the paper feeding mechanisms 19A and the paper feeding cassette 18B including the paper feeding mechanism 19B. Meaning described above applies in the same way in the description hereinafter.

The paper feeding mechanisms 19A (19B) pick up the sheet P from the paper feeding cassette 18A (18B) one by one and sends the sheet to a conveyance path of the sheet P. For example, the paper feeding mechanisms 19A (19B) may include pickup rollers, separating rollers, and paper feeding rollers.

The manual paper feeding unit **18C** includes a manual paper feeding mechanism **19C**. The manual paper feeding mechanism **19C** picks up the sheet P from the manual paper feeding unit **18C** one by one and sends the sheet to the conveyance path.

The printer unit **17** forms an image on the sheet P based on image data read by the scanner unit **15** or image data generated by a personal computer or the like. The printer unit **17** is, for example, a tandem type color printer.

The printer unit **17** includes image generating units **22Y**, **22M**, **22C**, and **22K** for each color of yellow (Y), magenta (M), cyan (C), and black (K) corresponding to color separating components of a color image, an exposure unit **23**, and an intermediate transfer belt **24**. In the embodiment, the printer unit **17** includes the four image generating units **22Y**, **22M**, **22C**, and **22K**.

Also, a configuration of the printer unit **17** is not limited to the above description, and the printer unit may include two or three image generating units, or may include five or more image generating units.

The image generating units **22Y**, **22M**, **22C**, and **22K** are disposed below the intermediate transfer belt **24**. The image generating units **22Y**, **22M**, **22C**, and **22K** are disposed in parallel along a downstream side from an upstream side in a moving direction of the intermediate transfer belt **24** below the intermediate transfer belt **24** (direction from left side toward right side in drawing).

In the exposure unit **23**, light sources, a polygon mirror, an f- θ lens, a reflecting mirror, and the like (none of which are illustrated) are included. The exposure unit **23** irradiates a front surface of a photoconductor **26K** and the like to be described later of each of the image generating units **22Y**, **22M**, **22C**, and **22K** with each of exposure light beams L_y , L_m , L_c , and L_k based on the image data.

The exposure unit **23** in one example generates a laser scanning beam as exposure light. The exposure unit **23** in another example includes a solid scanning element such as LED which generates exposure light.

A configuration of each of the image generating units **22Y**, **22M**, **22C**, and **22K** is the same as one another except toner colors which are different from each other. As a toner, either of a general color toner and a decolorable toner may be used. Decolorable toner is a toner which becomes transparent when the toner is heated at a certain temperature or more. The image forming apparatus **1** may be an image forming apparatus capable of using the decolorable toner, or may be an image forming apparatus not capable of using the decolorable toner.

Hereinafter, regarding a common configuration of each of the image generating units **22Y**, **22M**, **22C**, and **22K**, the image generating unit **22K** is given as an example.

As illustrated in FIG. 2, the image generating unit **22K** includes the photoconductor **26K**, a charger **27K**, a developer **28K**, and a cleaner **29K**. Also, in FIG. 1, with respect to only the image generating unit **22K**, reference numerals of the photoconductor **26K**, the charger **27K**, the developer **28K**, and the cleaner **29K** are illustrated.

As illustrated in FIG. 2, the photoconductor **26K** is formed in a drum shape. The photoconductor **26K** includes an electrostatic latent image formed by the exposure light beam L_k . The charger **27K** charges the front surface of the photoconductor **26K**. The developer **28K** supplies toner to the front surface of the photoconductor **26K**, and develops the electrostatic latent image. The cleaner **29K** cleans the front surface of the photoconductor **26K**.

As illustrated in FIG. 1, the intermediate transfer belt **24** is a belt with an endless shape. The intermediate transfer belt

24 is supported by a secondary transfer backup roller **32**, a cleaning backup roller **33**, and a tension roller **34**. In this example, when the secondary transfer backup roller **32** is rotated and driven, the intermediate transfer belt **24** circulates and travels in a direction illustrated by an arrow in FIG. 1.

Primary transfer rollers **36**, a secondary transfer roller **37**, and a belt cleaning mechanism **38** are disposed around the intermediate transfer belt **24**.

As illustrated in FIG. 2, the primary transfer roller **36** forms a primary transfer nip with the intermediate transfer belt **24** pinched between the photoconductor **26K** and the like and the roller. In addition, a power supply which is not illustrated is connected to the primary transfer roller **36**, and at least one of a predetermined direct current voltage (DC) and alternating current voltage (AC) is applied to the primary transfer roller **36**.

The secondary transfer roller **37** forms a secondary transfer nip with the intermediate transfer belt **24** pinched between the secondary transfer backup roller **32** and the roller. In addition, in the same manner as the primary transfer roller **36**, a power supply which is not illustrated is also connected to the secondary transfer roller **37**. At least one of a predetermined direct current voltage and alternating current voltage is applied to the secondary transfer roller **37**.

The belt cleaning mechanism **38** includes a cleaning brush and a cleaning blade which are provided to come into contact with the intermediate transfer belt **24**. A waste toner transfer hose, which is not illustrated, extending from the belt cleaning mechanism **38** is connected to an entrance of a waste toner container which is not illustrated.

As illustrated in FIG. 1, a supplying unit **41** is disposed on an upper portion of each of the image generating units **22Y**, **22M**, **22C**, and **22K**.

The supplying unit **41** supplies toner to each of the image generating units **22Y**, **22M**, **22C**, and **22K**. The supplying unit **41** includes toner cartridges **42Y**, **42M**, **42C**, and **42K**. The toner cartridges **42Y**, **42M**, **42C**, and **42K** respectively accommodate yellow, magenta, cyan, and black toners.

Each of the toner cartridges **42Y**, **42M**, **42C**, and **42K** includes a sign portion, which is not illustrated and causes a main controller **53** to be described later to detect the types of toners accommodated in each of the toner cartridges **42Y**, **42M**, **42C**, and **42K**. The sign portion includes at least information relating to colors of the toners of the toner cartridges **42Y**, **42M**, **42C**, and **42K** and information for identifying whether or not a toner is a general toner or a decolorable toner.

A supply passage which is not illustrated is provided between each of the toner cartridges **42Y**, **42M**, **42C**, and **42K** and the developers **28Y**, **28M**, **28C**, and **28K**. A toner is supplied to the developers **28Y**, **28M**, **28C**, and **28K** from a corresponding one of the toner cartridges **42Y**, **42M**, **42C**, and **42K** through the supply passage.

Paper feeding rollers **45A** and registration rollers **46** are provided on the conveyance path from the paper feeding cassette **18A** to the secondary transfer roller **37**. The paper feeding roller **45A** carries the sheet P picked up from the inside of the paper feeding cassette **18A** by the paper feeding mechanisms **19A**.

The registration rollers **46** adjust a position of a tip end of the sheet P fed from the paper feeding rollers **45A** at a position with which the registration rollers come into contact. The registration rollers **46** convey the sheet P to a secondary transfer nip.

Paper feeding rollers **45B** are provided on the conveyance path from the paper feeding cassette **18B** to the paper

feeding rollers 45A. The paper feeding rollers 45B convey the sheet P picked up from the paper feeding cassette 18B by the paper feeding mechanism 19B toward the paper feeding rollers 45A.

The conveyance path is formed between the manual paper feeding mechanism 19C and the registration rollers 46 by a conveying guide 48. The manual paper feeding mechanism 19C carries the sheet P taken out from the manual paper feeding unit 18C toward the conveying guide 48. The sheet P moving along the conveying guide 48 reaches the registration rollers 46.

A fixing unit 56 of the embodiment is disposed on a downstream side (upper side in drawing) of the secondary transfer roller 37 in the conveying direction of the sheet P.

Conveying rollers 50 are disposed on a downstream side (upper left side in drawing) of the fixing unit 56 in the conveying direction of the sheet P. The conveying rollers 50 discharge the sheet P to a paper discharging unit 51.

The reverse conveyance path 52 is disposed on a downstream side (right side in drawing) of the fixing unit 56 in the conveying direction of the sheet P. The reverse conveyance path 52 causes the sheet P to be reversed and guides the sheet to the secondary transfer roller 37 side. The reverse conveyance path 52 is used for duplex printing.

The image forming apparatus 1 includes the main controller 53 which controls the entire of the image forming apparatus 1. The main controller 53 includes a central processing unit (CPU), memory, and the like.

Next, the fixing unit 56 will be described in detail. The fixing unit 56 is a so-called direct heating type fixing unit.

As illustrated in FIG. 3, the fixing unit 56 includes a fixing belt 57, a pressure roller 58, a halogen heater 59, a reflector 60, a peeling unit 61, a temperature sensor 62, and a fixing controller 63.

The fixing belt 57 is formed of a material having flexibility, in a thin cylindrical shape. The fixing belt 57 is a belt having an endless shape. The fixing belt 57 includes a cylindrical shaped base material and a release layer which is disposed on an outer peripheral surface of the base material, neither of which is illustrated. The base material is made of a metal material such as nickel or stainless steel, or a resin material such as polyimide (PI). For the release layer, tetrafluoroethylene-perfluoroalkyl vinyl ether copolymer (PFA), polytetrafluoroethylene (PTFE), or the like is used.

Also, an elastic layer, which is made of a rubber material such as silicone rubber, expandable silicone rubber, or fluororubber, may be interposed between the base material and the release layer.

A supporting member 65 is fit at both end portions of the fixing belt 57 in a shaft direction (hereinafter, simply referred to as shaft direction). The supporting member 65 includes a disk shaped large diameter portion 66 and a cylindrical shaped small diameter portion 67. The diameter of the large diameter portion 66 is greater than the diameter of the small diameter portion 67. The small diameter portion 67 is coaxially fixed to the large diameter portion 66. The small diameter portion 67 is inserted into an end portion of the fixing belt 57 in the shaft direction. The supporting member 65 maintains a shape of both end portions of the fixing belt 57 in the shaft direction. However, an intermediate portion of the fixing belt 57 in the shaft direction is easily deformed because the supporting member 65 is not fit thereto.

The fixing belt 57 is rotatable around a shaft of the fixing belt 57 in a state of being supported by the supporting member 65.

In the embodiment, the pressure roller 58 and the fixing belt 57 extend in parallel directions along a horizontal plane. Hereinafter, a direction from the fixing belt 57 toward the pressure roller 58 along the horizontal plane is referred to as a right side X1. A direction from the pressure roller 58 toward the fixing belt 57 along the horizontal plane is referred to as a left side X2.

The pressure roller 58 includes a core metal 58a, an elastic layer 58b, and a release layer 58c.

The core metal 58a is formed of a metal or the like in a cylindrical shape. Both end portions of the core metal 58a are supported by a supporting member (not illustrated) in the fixing unit 56 through a bearing (not illustrated). The core metal 58a is rotatable around the supporting member through the bearing.

The elastic layer 58b is made of expandable silicone rubber, silicon rubber, fluororubber, or the like, and is provided on the outer peripheral surface of the core metal 58a. The release layer 58c is made of PFA, PTFE, or the like, and is provided on the outer peripheral surface of the elastic layer 58b.

The pressure roller 58 is pressurized by a pressurizing unit, which is not illustrated, toward the left side X2 (fixing belt 57 side) so as to be in contact with an outer peripheral surface of the fixing belt 57. The pressure roller 58 presses against a nip forming member 69 through the fixing belt 57. The nip forming member 69 is disposed inside a circumference of the fixing belt 57. The nip forming member 69 will be described later.

In a part of the pressure roller 58 that presses against the fixing belt 57, the elastic layer 58b of the pressure roller 58 is compressed, and thus a fixing nip N having a predetermined width is formed in the conveying direction of the sheet P. In the fixing nip N, the pressure roller 58 presses the sheet P against the fixing belt 57. Hereinafter, the part of the fixing belt 57 for forming the fixing nip N is referred to as a nip forming portion 57e.

The pressure roller 58 is rotated and driven by a driving source such as a motor, which is not illustrated, provided in the main body 11. When the pressure roller 58 is rotated and driven, a driving force thereof is transmitted to the fixing belt 57 through the fixing nip N, and the fixing belt 57 is driven and rotated. The fixing belt 57 is rotated in a first circumferential direction D1 of the fixing belt 57 when conveying the sheet P.

Also, a heating source such as a halogen heater may be provided inside the core metal 58a of the pressure roller 58. In addition, if the pressure roller 58 does not include the elastic layer 58b, heat capacity of the pressure roller decreases such that fixing property is improved.

Meanwhile, when unfixed toner is compressed to be fixed, minute undulations on the front surface of the fixing belt 57 are transferred to the image, and it is possible for gloss unevenness to be generated on a solid portion of the image. In order to prevent transferring of the minute undulations and generating of the gloss unevenness, it is preferable that the elastic layer 58b having a thickness of 150 μm (micrometer) or more is provided on the pressure roller 58. When the elastic layer 58b having the thickness of 150 μm or more is provided, the minute undulations can be absorbed due to elastic deformation of the elastic layer 58b, and thereby making it possible to avoid generation of the gloss unevenness.

The elastic layer 58b may be made of solid rubber, but if there is no heating source inside the pressure roller 58, the elastic layer 58b may be made of sponge rubber. It is desirable that the elastic layer 58b is made of sponge rubber,

because a heat insulating property of the elastic layer **58b** is high so that heat of the fixing belt **57** is not easily transferred to the pressure roller **58**.

The pressure roller **58** may be configured to be hollow, or may be configured to be solid.

The fixing unit **56** includes a plurality of the halogen heaters **59** (two in this embodiment). Also, the number of the halogen heaters **59** included in the fixing unit **56** may be one or three or more.

The halogen heaters **59** are disposed inside the fixing belt **57** along a shaft direction of the fixing belt **57**. Each end portion of the halogen heaters **59** is fixed to the small diameter portion **67** or the like of the supporting member **65**. The halogen heaters **59** are disposed to face the inner circumference of the fixing belt **57**. The halogen heaters **59** generate heat for heating the fixing belt **57** by controlling an output of a power source (not illustrated) provided in the main body **11**.

It is not illustrated, but the nip forming member **69** includes a base pad and a sliding sheet.

The base pad is formed of a heat resistance member having a heat resistant temperature 200° C. or more. Accordingly, in a toner fixing temperature range, deformation of the base pad due to heat is prevented. Further, a stable state of the fixing nip N is secured, and stabilization of output image quality is achieved.

The base pad has a function of determining a shape of the fixing nip N, which is formed by the pressure roller **58**, facing the base pad pinching the sliding sheet between the roller and the pad. Therefore, a surface of the fixing nip N facing the base pad is substantially flat.

In order to maintain such a shape of the base pad, hard material is used for the base pad. Specifically, crystalline thermoplastic plastics being used for liquid crystal polymer (LCP) or the like, for example, molded articles such as aramid fibers are used. In addition, instead of resin, materials such as metals or ceramics which are capable of maintaining the shape thereof may be used.

Also, to the base pad, general heat resistant resin may be used, such as polyether sulfone (PES), polyphenylene sulfide (PPS), liquid crystal polymer (LCP), polyether nitrile (PEN), polyamide imide (PAI), and polyether ether ketone (PEEK).

The sliding sheet is a low friction sheet and covers the front surface of the base pad. The sliding sheet is made of, for example, PTFE. When the fixing belt **57** is rotated, the fixing belt **57** is slid on a front surface of the sliding sheet. Therefore, a driving torque being generated in the fixing belt **57** when the fixing belt **57** slides along the sliding sheet is reduced, and thereby making it possible to reduce load being generated due to a frictional force to the fixing belt **57**.

The nip forming member **69** is disposed to extend along the shaft direction. The nip forming member **69** is supported by the stay **70**.

The stay **70** is disposed at the center of an inner circumference area of the fixing belt **57**. The stay **70** includes an upper supporting plate **73**, a connecting member **74**, and a lower supporting plate **75**. The upper supporting plate **73** is disposed so that a thickness direction thereof is along a vertical direction (i.e., the upper supporting plate **73** is along a horizontal plane). A plurality of protruding portions **73a** which protrude from the upper supporting plate **73** toward the upper side are provided on an upper surface of the upper supporting plate **73**. The plurality of protruding portions **73a** are disposed with intervals therebetween along a horizontal direction X on an upper surface of the upper supporting plate **73**.

The connecting member **74** protrudes downward from a left end portion of the upper supporting plate **73**. The lower supporting plate **75** is partially inclined downward along a direction toward the right side X1 from a lower end portion of the connecting member **74**. In the stay **70** having such a configuration, when viewed along the shaft direction, the stay **70** is formed in a U-letter shape with its right side opened.

When the nip forming member **69** is supported by the stay **70**, bending of the nip forming member **69** due to pressure from the pressure roller **58** is prevented, and uniform width of the fixing nip N along the shaft direction can be obtained. Also, the stay **70** is desirably formed of a metal material having a high mechanical rigidity such as stainless steel (SUS) or iron in order to prevent the nip forming member **69** from being bent. Alternatively, the stay **70** may be formed of resin.

The reflector **60** includes a top board **78**, a connecting board **79**, a bottom board **80**, a first overhanging board **81**, a second overhanging board **82**, and an evacuation board **83**. The reflector **60** is formed by bending a board material. The board material for forming the reflector **60** is preferably, for example, a metal material having a relatively high melting point such as aluminum or stainless steel. The reflector **60** is disposed within the inner circumference of the fixing belt **57**, and reflects heat generated from the plurality of halogen heaters **59** toward the fixing belt **57**.

The top board **78** is disposed on the upper side of the upper supporting plate **73** of the stay **70** so as to face the upper supporting plate **73**. The lower surface of the top board **78** is in contact with the plurality of protruding portions **73a** of the upper supporting plate **73**. A gap is formed between the top board **78** and the upper supporting plate **73**. Because of the gap, heat of the reflector **60** is not easily transmitted to the upper supporting plate **73** of the stay **70**.

The connecting board **79** is gradually inclined toward the left side X2 from the left end portion of the top board **78** to the bottom. The connecting board **79** is disposed on the left side X2 of the connecting member **74**.

The bottom board **80** is partially inclined downward from the lower end portion of the connecting board **79** toward the right side X1. The bottom board **80** is in contact with the lower supporting plate **75** from the bottom of the lower supporting plate **75**. A first extension board **85** extending downward is provided on a right end portion of the bottom board **80**. A second extension board **86** protruding toward the right side X1 is provided on a lower end portion of the first extension board **85**. The second extension board **86** is an end portion of the reflector **60** in a second circumferential direction D2 of the fixing belt **57** from where the fixing nip N is pinched. The second direction D2 is a direction opposite to the first direction D1 in the circumferential direction.

The halogen heaters **59** described above are disposed on the left side X2 of the first extension board **85** down below the bottom board **80**. The bottom board **80** and the first extension board **85** of the reflector **60** reflect heat generated from the plurality of halogen heaters **59** toward a range R1 of the fixing belt **57**. That is, the range R1 is a range where heat is reflected by the reflector **60** in the fixing belt **57**.

When heat is reflected by the reflector **60**, amount of heat being applied to the fixing belt **57** from the halogen heaters **59** can be increased, and the fixing belt **57** can be efficiently heated. In addition, transmission of radiation heat from the halogen heaters **59** to the stay **70** or the like is suppressed, and thus energy saving is achieved.

Also, reflectance of a reflective surface of the reflector **60** or the stay **70** is desirably 90% or more.

It is not possible to freely select a shape or a material of the stay **70** in order to ensure strength thereof. Therefore, when the reflector **60** is separately provided from the stay **70** as in the embodiment, a degree of freedom in selecting the shape or the material of the stay **70** is increased. Further, it is possible to specialize each function of the reflector **60** and the stay **70**.

In addition, when the reflector **60** is provided between the halogen heaters **59** and the stay **70**, a distance between the halogen heaters **59** and the reflector **60** is shortened, and thus the fixing belt **57** can be efficiently heated due to heat reflected by the reflector **60**.

The first overhanging board **81** is gradually inclined toward the left side X2 from a right end portion of the top board **78** toward the upper side. The second overhanging board **82** is gradually inclined upward from the upper end portion of the first overhanging board **81** toward the left side X2. The second overhanging board **82** is inclined toward the left side X2 of the first overhanging board **81**. The evacuation board **83** is inclined downward from a left end portion of the second overhanging board **82** toward the left side X2. The evacuation board **83** is an end portion of the reflector **60** in the first circumferential direction D1 from where the fixing nip N is pinched. The second overhanging board **82** is a part adjacent and connected to the evacuation board **83** in the reflector **60** in the second circumferential direction D2.

The evacuation board **83** is disposed within the inner circumference of the fixing belt **57** in a radial direction relative to the second overhanging board **82**.

A connection part **88** between the first overhanging board **81** and the second overhanging board **82** protrudes to the outside in the radial direction more than other parts of the overhanging boards **81** and **82**. The connection part **88** comes into contact with the inner circumference of the fixing belt **57**. Hereinafter, the part of the fixing belt with which the connection part **88** comes into contact is referred to as an overhanging portion **57a**. The overhanging portion **57a** is disposed on a downstream side of the fixing nip N in the fixing belt **57** in the conveying direction of the sheet P.

The connection part **88** causes the overhanging portion **57a** to protrude outwardly in the radial direction more than parts **57b** and **57c** adjacent to the overhanging portion **57a** in the fixing belt **57**, and to increase a curvature (to decrease curvature radius) thereof.

The evacuation board **83** is separated in the radial direction from the fixing belt **57** (i.e., is not in contact with the fixing belt **57**). Also, the top board **78**, the connecting board **79**, the bottom board **80**, the first extension board **85**, and the second extension board **86** of the reflector **60** are also separated from the fixing belt **57** in the radial direction.

The first overhanging board **81**, the second overhanging board **82**, and the evacuation board **83** may be disposed along the entire length of the fixing belt **57** in the shaft direction or just the center portions along the length of the fixing belt **57** in the shaft direction.

The reflector **60** having such a configuration is fixed to the stay **70** by a screw or the like which is not illustrated.

A shape of the peeling unit **61** is not particularly limited. In the embodiment, the peeling unit **61** includes a main body **91** and a supporting member **92**. The main body **91** is formed in a board shape using resin, a metal, or the like. A distal end portion of the main body **91** is disposed on a downstream side of the overhanging portion **57a** in a conveying direction so as to be adjacent to the overhanging portion **57a**. The distal end portion of the main body **91** is preferably disposed

at the same position as that of the overhanging portion **57a** in the radial direction or inwardly of the overhanging portion **57a** in the radial direction. The main body **91** preferably extends in a tangential direction of the fixing belt **57** at the part of the fixing belt **57** that is adjacent to the distal end portion of the main body **91**.

The supporting member **92** supports a base end portion of the main body **91**.

As the temperature sensor **62**, a non-contact type sensor is used in the embodiment. Also, a contact type sensor may be used as a temperature sensor.

The temperature sensor **62** measures a temperature of a measuring target portion **57d** in the fixing belt **57**. The measuring target portion **57d** is the part of the fixing belt **57** on the first circumferential direction D1 side of the nip forming portion **57e**, and the second circumferential direction D2 side of the range R1. The nip forming portion **57e**, the overhanging portion **57a**, and the measuring target portion **57d** are arranged in the first circumferential direction D1 in that order.

The temperature sensor **62** periodically transmits a temperature measurement result to the fixing controller **63**.

The fixing controller **63** includes a central processing unit (CPU), a memory, and the like. The fixing controller **63** controls the fixing unit **56**.

Next, operations of the image forming apparatus **1** having such a configuration will be described based on operations of the fixing unit **56**.

For example, an operator reads image data by reading a document using the scanner unit **15**. The main controller **53** transmits an instruction for starting a warm-up operation to the fixing controller **63** of the fixing unit **56**.

The fixing controller **63** drives the halogen heaters **59**. Heat generated from the halogen heaters **59** directly heats the fixing belt **57**. Meanwhile, the heat which is generated from the halogen heaters **59** and reflected by the reflector **60** indirectly heats a part of the fixing belt **57** in the range R1. That is, a temperature of the part of the fixing belt **57** in the range R1 is increased more than that of the other parts of the fixing belt **57**.

The temperature of the reflector **60** is increased due to the heat generated from the halogen heaters **59**. Heat of the reflector **60** is transmitted to the overhanging portion **57a** of the fixing belt **57** in contact with the connection part **88** from the connection part **88** of the reflector **60**.

The fixing controller **63** adjusts outputting of the halogen heaters **59** based on the measured result of the temperature sensor **62**, and adjusts the temperature of the measuring target portion **57d** of the fixing belt **57** to become a predetermined temperature.

The main controller **53** rotates and drives the pressure roller **58** by a driving source. With a driving force thereof, the fixing belt **57** is rotated in the first circumferential direction D1.

The main controller **53** transfers each toner image generated by the image generating units **22Y**, **22M**, **22C**, and **22K** of the printer unit **17** to the sheet P inside the paper feeding cassette **18A** based on the image data read by the scanner unit **15**. The sheet P to which each toner image is transferred is conveyed into the fixing unit **56** from the bottom of the fixing unit **56** as illustrated in FIG. 3. When the sheet passes through the fixing nip N of the fixing unit **56**, the sheet P and each toner image are heated, and each toner image is fixed onto the sheet P. When the sheet P passes through the overhanging portion **57a** of the fixing belt **57**, the distal end portion of the main body **91** of the peeling unit **61** is inserted between the fixing belt **57** and the sheet

11

P. The peeling unit **61** separates the sheet P from the fixing belt **57**. The separated sheet P is moved to a position illustrated by two-dot chain line in FIG. **3**.

The main controller **53** discharges the sheet P passed through the fixing unit **56** to the paper discharging unit **51** by the conveying rollers **50**.

As described above, in the fixing unit **56** of the embodiment, the reflector **60** is in contact with the fixing belt **57**. Heat generated by the halogen heaters **59** and reflected from the reflector **60** is transmitted to the fixing belt **57**, and thus heat transfer efficiency from the halogen heaters **59** to the fixing belt **57** can be improved.

Even when reflectance of the reflector **60** is 90% or more, as the halogen heaters **59** become a higher output power, the temperature of the reflector **60** is increased so as to exceed, for example, 300° C. In this case, efficiency of the halogen heaters **59** for heating the fixing belt **57** decreases. When the connection part **88** in contact with the fixing belt **57** is formed in the reflector **60**, heat energy accumulated in the reflector **60** is supplied to the fixing belt **57**, and the fixing unit **56** can be correspond to the image forming apparatus **1** performing high speed printing.

The fixing unit **56** includes the peeling unit **61** in which a distal end portion adjacent to the overhanging portion **57a** is disposed on a downstream side of the overhanging portion **57a** in the conveying direction. Accordingly, the peeling unit **61** is inserted between the fixing belt **57** and the sheet P, and it is possible to easily peel off the sheet P from the fixing belt **57**.

The measuring target portion **57d** in which the temperature is measured by the temperature sensor **62** in the fixing belt **57** is positioned on the first circumferential direction D1 side of the overhanging portion **57a** in the fixing belt **57** to which heat is transmitted by the reflector **60**, and on the second circumferential direction D2 side of a part of the fixing belt **57** in the range R1. Accordingly, based on a temperature of the measuring target portion **57d** of the fixing belt **57** before being indirectly heated by the reflector **60** after being heated by the connection part **88** of the reflector **60**, it is possible to stably control the temperature of the fixing belt **57**.

In the reflector **60**, the evacuation board **83** is disposed in the inside of the second overhanging board **82** in the radial direction. Accordingly, the evacuation board **83** cannot be easily hooked by the fixing belt **57**.

In addition, according to the image forming apparatus **1** of the embodiment, it is possible to configure the image forming apparatus **1** using the fixing unit **56** in which heat transfer efficiency from the halogen heaters **59** to the fixing belt **57** is improved.

Also, the heating unit is the halogen heater **59**. However, the heating unit is not limited thereto, and an induction heating (IH) heater or the like may be used.

In alternative embodiments, the fixing unit **56** may not include the peeling unit **61**, the temperature sensor **62**, the evacuation board **83** of the reflector **60**. If the fixing unit **56** does not include the temperature sensor **62**, a position where the reflector **60** is in contact with the fixing belt **57** is not particularly limited.

According to at least one of the embodiments described above, the reflector **60** is included, and thus heat transfer efficiency from the halogen heaters **59** to the fixing belt **57** can be improved.

While certain embodiments have been described, these embodiments have been presented by way of example only, and are not intended to limit the scope of the inventions. Indeed, the novel embodiments described herein may be

12

embodied in a variety of other forms; furthermore, various omissions, substitutions and changes in the form of the embodiments described herein may be made without departing from the spirit of the inventions. The accompanying claims and their equivalents are intended to cover such forms or modifications as would fall within the scope and spirit of the inventions.

What is claimed is:

1. A fixing device comprising:

- a belt that is rotatable in a rotational direction;
- a roller positioned to be in contact with an outer peripheral surface of the belt so as to form a nip between the roller and the belt;
- a heater disposed within an inner circumference of the belt; and
- a reflector configured to reflect heat generated by the heater toward an inner surface of the belt, the reflector including a first portion that is in contact with the belt at a first region downstream with respect to the nip in the rotational direction, the first portion causing a curvature of the belt at the first region to be greater than the curvature of the belt at regions of the belt adjacent to the first region.

2. The fixing device according to claim **1**, wherein the reflector is bent to form a concave reflecting surface that faces the heater.

3. The fixing device according to claim **1**, wherein the reflector comprises a board material that is bent a plurality of times.

4. The fixing device according to claim **1**, wherein the reflector is in contact with the first region of the belt and no other regions of the belt.

5. The fixing device according to claim **1**, further comprising:

- a fixed support against which the roller presses the belt, wherein

the reflector covers the fixed support, and

- a plurality of gaps are formed between the reflector and the fixed support so as to suppress heat conduction from the reflector to the fixed support.

6. The fixing device according to claim **5**, wherein the reflector is not provided between the belt and the roller at the nip.

7. The fixing device according to claim **5**, further comprising:

- a peeling unit configured to peel a sheet that has been fed into the nip and pressed against the belt by the roller at a position adjacent to the first region of the belt.

8. The fixing device according to claim **5**, further comprising:

- a temperature sensor positioned to measure a temperature of a measuring target portion of the belt, wherein the measuring target portion is downstream with respect to the first region of the belt in the rotational direction.

9. The fixing device according to claim **5**, wherein the reflector comprises a board material that is bent a plurality of times.

10. The fixing device according to claim **5**, wherein the reflector is in contact with the first region of the belt and no other regions of the belt.

11. The fixing device according to claim **5**, wherein the reflector is bent to form a concave reflecting surface that faces the heater.

12. The fixing device according to claim **5**, wherein the reflector is bent to form a concave reflecting surface that faces the heater.

13

13. An image forming apparatus comprising:
 a cassette; and
 an image forming unit configured to form a toner image
 on a sheet supplied from the cassette,
 wherein the image forming unit includes a fixing unit
 configured to fix the toner image on the sheet, the fixing
 unit including:
 a belt that is rotatable in a rotational direction,
 a roller positioned to be in contact with an outer
 peripheral surface of the belt so as to form a nip
 between the roller and the belt,
 a heater disposed within an inner circumference of the
 belt,
 a reflector configured to reflect heat generated by the
 heater toward an inner surface of the belt, the reflec-
 tor including a first portion that is in contact with the
 belt at a first region downstream with respect to the
 nip in the rotational direction, the first portion caus-
 ing a curvature of the belt at the first region to be
 greater than the curvature of the belt at regions of the
 belt adjacent to the first region, and
 a fixed support against which the roller presses the belt,
 wherein
 the reflector covers the fixed support, and
 a plurality of gaps are formed between the reflector and
 the fixed support so as to suppress heat conduction
 from the reflector to the fixed support.

14

14. The image forming apparatus according to claim 13,
 wherein the reflector is not provided between the belt and the
 roller at the nip.
 15. The image forming apparatus according to claim 13,
 wherein the fixing unit further includes a peeling unit
 configured to peel a sheet that has been fed into the nip and
 pressed against the belt by the roller at a position adjacent to
 the first region of the belt.
 16. The image forming apparatus according to claim 13,
 further comprising:
 a temperature sensor positioned to measure a temperature
 of a measuring target portion of the belt, wherein
 the measuring target portion is downstream with respect
 to the first region of the belt in the rotational direction.
 17. The image forming apparatus according to claim 13,
 wherein the reflector comprises a board material that is bent
 a plurality of times.
 18. The image forming apparatus according to claim 13,
 wherein the reflector is in contact with the first region of the
 belt and no other regions of the belt.
 19. The image forming apparatus according to claim 13,
 wherein the reflector is bent to form a concave reflecting
 surface that faces the heater.
 20. The image forming apparatus according to claim 13,
 wherein the reflector is bent to form a concave reflecting
 surface that faces the heater.

* * * * *