

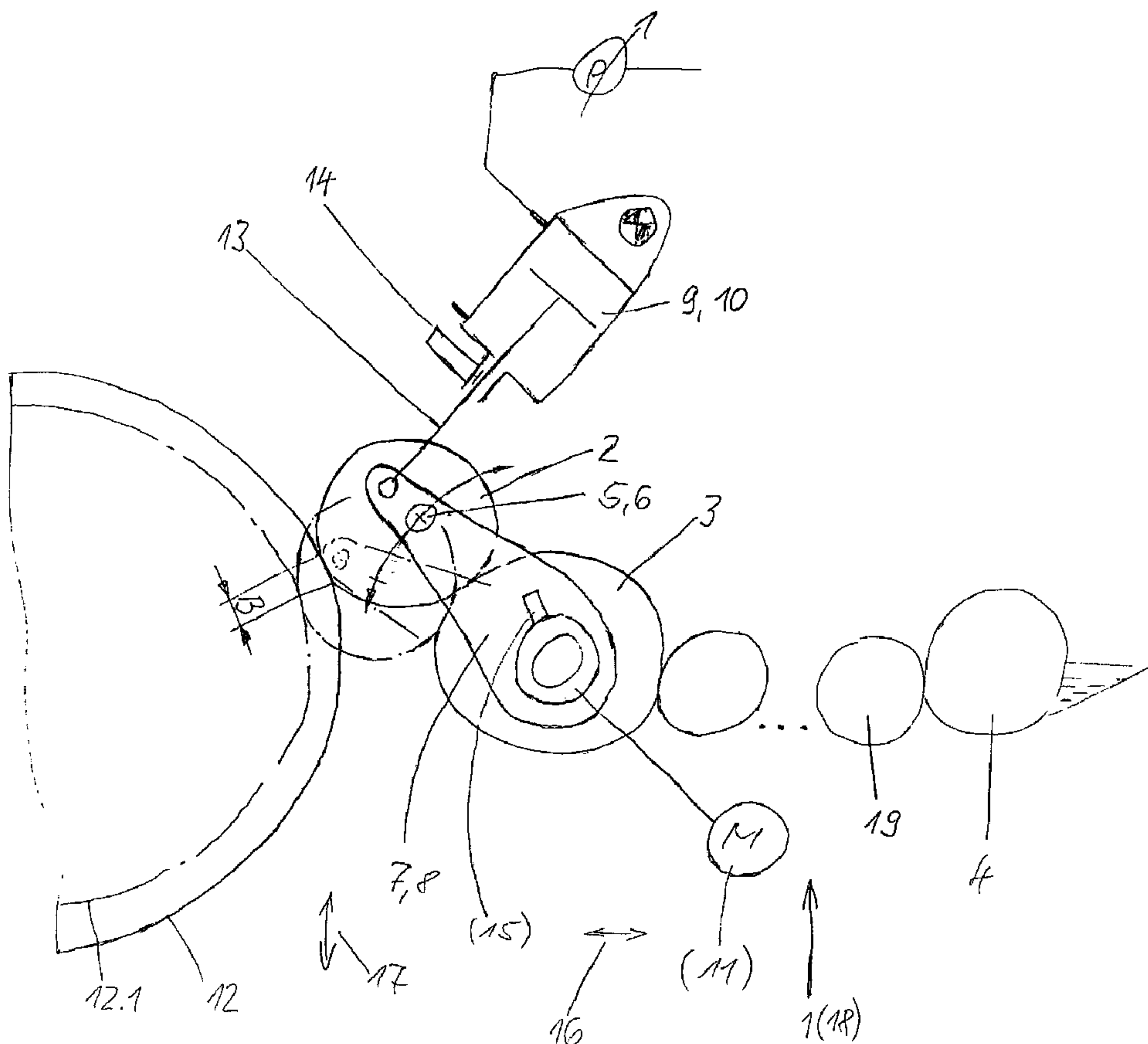

(86) Date de dépôt PCT/PCT Filing Date: 2003/04/03
 (87) Date publication PCT/PCT Publication Date: 2003/10/16
 (45) Date de délivrance/Issue Date: 2008/12/30
 (85) Entrée phase nationale/National Entry: 2004/09/28
 (86) N° demande PCT/PCT Application No.: EP 2003/003455
 (87) N° publication PCT/PCT Publication No.: 2003/084754
 (30) Priorité/Priority: 2002/04/08 (DE102 15 422.8)

(51) Cl.Int./Int.Cl. *B41F 31/30* (2006.01),
B41F 31/26 (2006.01), *B41F 31/36* (2006.01)
 (72) Inventeur/Inventor:
BACHMEIR, XAVER, DE
 (73) Propriétaire/Owner:
MANROLAND AG, DE
 (74) Agent: OGILVY RENAULT LLP/S.E.N.C.R.L.,S.R.L.

(54) Titre : DISPOSITIF D'ENCRAGE OU DE MOUILLAGE D'UNE PRESSE ROTATIVE
 (54) Title: INKING OR DAMPENING UNIT OF A ROTARY PRESS



(57) Abrégé/Abstract:

An inking or dampening unit includes an applicator roll mounted on levers so that the application roll can be pivoted about a distributor cylinder onto a form cylinder with a controlled throwing-on force.

Abstract

An inking or dampening unit includes an applicator roll mounted on levers so that the application roll can be pivoted about a distributor cylinder onto a form cylinder with a controlled throwing-on force.

Inking or dampening unit of a rotary pressFIELD OF THE INVENTION

The invention relates to an inking or dampening unit of
5 a rotary press, having at least one applicator roll
pivotally mounted on levers so that the applicator roll
is pivotable onto a form cylinder of the rotary press.

BACKGROUND OF THE INVENTION

10 GB 2132944 discloses an inking unit, in which an ink
applicator roll can be pivoted about a distributor
cylinder and can be thrown onto a form cylinder at the
same time. The applicator roll is mounted on both sides
in levers. Adjustable stops against which the levers
15 can be moved serve to adjust the applicator roll on the
form cylinder. A disadvantage is the complexity of the
setting and subsequent adjustment of the stops.

SUMMARY OF THE INVENTION

20 It is an object of the invention to provide an inking
or dampening unit which is distinguished by low setting
and adjusting complexity of the applicator rolls.

In accordance with a first broad aspect of the present
25 invention, there is provided an inking or dampening
unit of a rotary press, having at least one applicator
roll which is mounted on both sides in levers and can
be set against a form cylinder in a pivotable manner
about a distributor cylinder by means of the levers,
30 characterized in that the applicator roll can be
pivoted against the form cylinder with a controlled
throwing-on force by means of at least one motor.

- 2 -

The applicator roll is thrown onto the form cylinder with a defined force by performing the throwing-on action with a controlled force. The contact force (reaction force) is in equilibrium with the throwing-on
5 force and is automatically set. The contact force can be selected by varying the throwing-on force and it is thus easier to set what is known as the imprint width. The throwing-on action is not sensitive to positional deviations of the inking or dampening unit with respect
10 to the form cylinder, as the applicator roll finds its equilibrium automatically by an appropriate pivoting movement. Subsequent adjustments can also be performed automatically in this way, for example in the event of swelling or shrinking of the applicator roll or changes
15 in diameter as a result of thermal expansion.

The applicator roll can also follow limited movements of the form cylinder, for example the print throwing-on and throwing-off movement, while maintaining its
20 setting.

The proposed throwing-on action also makes it possible to use form cylinders of different diameter, onto which the applicator roll can be thrown in a self-adjusting
25 manner. As a result, it is no longer necessary to rebuild the inking or dampening unit if the format of the printing press is changed, and it is possible to realize a uniform inking and dampening unit configuration for a range of formats of form cylinders.

30

BRIEF DESCRIPTION OF THE DRAWINGS

The invention is to be explained in greater detail in the following text using an exemplary embodiment.

Figure 1 diagrammatically shows an inking unit of a rotary press, having an applicator roll which can be thrown onto a form cylinder.

5

DETAILED DESCRIPTION OF THE PREFERRED EMBODIMENTS

Figure 1 shows an inking unit 1, of which only an applicator roll 2 and a distributor cylinder 3 are shown. Furthermore, a wedge-shaped ink fountain 4 is shown, by way of example, as the ink source, ink transport rolls 19 which are only indicated diagrammatically transporting ink from said ink fountain 4 to the distributor cylinder 3.

15 The applicator roll 2 is mounted at both ends with its journals 5, 6 in levers 7, 8. The levers 7, 8 can be pivoted about the rotational axis of the distributor cylinder 3. For this purpose, they are mounted, for example, on the journals of the distributor cylinder 3 or in side walls (not shown), in which the distributor cylinder 3 is also mounted.

In each case one linear motor in the form of an operating cylinder 9, 10 acts in a pivotably mounted manner on the levers 7, 8. A spring or an electric attraction magnet, for example, could also be used as linear motor. Instead of by means of operating cylinders, the levers 7, 8 can also be acted on by means of a rotary motor, for example by means of an electric, pneumatic or hydraulic motor or in a manner based on spring force. A rotary motor 11 of this type is indicated in the figure in thin lines with an item number in brackets.

30

The applicator roll 2 can be pivoted against a form cylinder 12 by pivoting the levers 7, 8. For this purpose, a fluid, preferably compressed air, is supplied to the operating cylinders 9, 10 at a selected pressure p , the piston rods 13 of said operating cylinders 9, 10 extending and the levers 7, 8 moving into the drawn position together with the applicator roll 2. The pressure p is selected here in such a way that the throwing-on force which acts on the levers 7, 8 produces a contact force which brings about the desired imprint width B of the applicator roll 2 on the form cylinder 12. Subsequently, the position of the applicator roll 2 is locked by means of a locking apparatus 14. Instead of this, locking apparatuses 15 (denoted in the figure by thin lines and an item number in brackets) can also be arranged on the levers 7, 8.

The locking apparatus 14 can also be released temporarily during continuous printing, as a result of which the thrown-on position of the applicator roll 2 is subsequently adjusted automatically, that is to say the levers 7, 8 are thrown on further or moved back in the event, for example, of a swollen or shrunk applicator roll 2 or a change in diameter as a consequence of thermal expansion. It is also possible to operate the inking unit 1 without locking the thrown-on position of the applicator roll 2, as a result of which automatic subsequent adjustment is performed constantly. After it has been thrown onto the form cylinder 12, it is also possible to operate the applicator roll 2 initially at a defined speed during the running-in period of the inking unit 1 and

without locking its position for a defined time period. As a result, the applicator roll 2 can, for example, yield to initial imbalances due to non-uniform colour distribution. Advantageously, the applicator roll 2 is
5 initially thrown on with a higher throwing-on force compared with later operation, in that the operating cylinders 9, 10 are fed initially at a higher pressure p. As a result, throwing-on actions which are too brief as a consequence of static friction are avoided.

10

In a further design variant, it is also possible to displace the inking unit 1 in the direction 16 toward the form cylinder 12 after the applicator roll 2 has been thrown onto the form cylinder 12 and this position
15 has been locked. This procedure also compensates for the throwing-on actions which are too brief as a consequence of static friction.

It is also possible to throw the applicator roll 2 onto
20 the form cylinder 12 situated in the print thrown-off position, to lock this position, and to move the form cylinder 12 into the print thrown-on position in the direction 17 and in the process to move the inking unit 1 simultaneously in the direction 17. Means for moving
25 an inking unit are disclosed in US Patent No. 6,502,509.

The applicator roll 2 can also be thrown onto a form cylinder 12.1 having a different diameter while
30 retaining the position of the inking unit 1. This case is also illustrated in the figure using a dash-dotted line. Here, the pivoting levers 7, 8 follow a greater pivoting path during the throwing-on action, until the

- 6 -

applicator roll 2 then comes into contact with the form cylinder 12.1, which contact then occurs with approximately the same contact force and imprint width B as on the larger form cylinder 12.

5

The applicator roll 2 can also be a dampening solution applicator roll of a dampening unit 18 (denoted with an item number in brackets).

The embodiments of the invention in which an exclusive property or privilege is claimed are defined as follows:

5

1. An inking or dampening unit of a rotary press, having at least one applicator roll which is mounted on both sides in levers and can be set against a form cylinder in a pivotable manner
10 about a distributor cylinder by means of the levers, characterized in that the applicator roll can be pivoted against the form cylinder with a controlled throwing-on force by means of at least one motor, and the applicator roll and distributor
15 cylinder remain in constant contact with one another.

2. The inking or dampening unit as claimed in claim 1, characterized in that the applicator roll can
20 be pivoted by means of one of linear motors and a rotary motor.

3. The inking or dampening unit as claimed in claim 1, characterized in that the setting force of the
25 motor can be adjusted to set desired imprint widths (B).

4. The inking or dampening unit as claimed in any one of claims 1 to 3, characterized in that the
30 applicator roll can initially be thrown on with a higher throwing-on force compared with later operation.

- 8 -

5. The inking or dampening unit as claimed in any one of claims 1 to 4, characterized in that the setting force of the motor is variable so as to compensate for various reaction effects of the weight of the applicator roll in different operating states.
6. The inking or dampening unit as claimed in any one of claims 1 to 5, characterized in that it is possible to lock the position of the applicator roll in the thrown-on position.
7. The inking or dampening unit as claimed in claim 1, characterized in that it is possible to lock the motor.
8. The inking or dampening unit as claimed in claim 6, characterized in that it is possible to lock the levers.
9. The inking or dampening unit as claimed in any one of claims 6 to 8, characterized in that the applicator roll can be locked immediately after it is thrown onto the form cylinder or after a running-in period.
10. The inking or dampening unit as claimed in any one of claims 6 to 9, characterized in that it is possible to adjust the applicator roll, which has been thrown against the form cylinder and locked, with respect to the form cylinder together with the inking unit or dampening unit.

- 9 -

11. The inking or dampening unit as claimed in any one of claims 6 to 10, characterized in that it is possible to throw the applicator roll against the form cylinder situated in the print thrown-off position, to lock it in this position and to displace it together with the form cylinder into the print thrown-on position of the latter.
- 5
- 10 12. The inking or dampening unit as claimed in any one of claims 1 to 11, characterized in that it is possible to throw the applicator roll against form cylinders having different diameters.

