

(19) World Intellectual Property Organization
International Bureau



(43) International Publication Date
22 October 2009 (22.10.2009)

PCT

(10) International Publication Number
WO 2009/129329 A1

(51) International Patent Classification:
A61N 1/05 (2006.01)

(21) International Application Number:
PCT/US2009/040700

(22) International Filing Date:
15 April 2009 (15.04.2009)

(25) Filing Language: English

(26) Publication Language: English

(30) Priority Data:
12/104,230 16 April 2008 (16.04.2008) US

(71) Applicant (for all designated States except US): **NEVRO CORPORATION** [US/US]; 411 Acacia Avenue, Palo Alto, CA 94306 (US).

(72) Inventors; and

(75) Inventors/Applicants (for US only): **BOLING, C., Lance** [US/US]; 4615 Royal Grove Court, San Jose, CA 95136 (US). **MAKOUS, James** [US/US]; 22024 Jeffers Lane, Santa Clarita, CA 91350 (US).

(74) Agent: **WECHKIN, John, M.**; Perkins Coie LLP, P.O. Box 1247, Seattle, WA 98111-1247 (US).

(81) Designated States (unless otherwise indicated, for every kind of national protection available): AE, AG, AL, AM, AO, AT, AU, AZ, BA, BB, BG, BH, BR, BW, BY, BZ, CA, CH, CN, CO, CR, CU, CZ, DE, DK, DM, DO, DZ, EC, EE, EG, ES, FI, GB, GD, GE, GH, GM, GT, HN, HR, HU, ID, IL, IN, IS, JP, KE, KG, KM, KN, KP, KR, KZ, LA, LC, LK, LR, LS, LT, LU, LY, MA, MD, ME, MG, MK, MN, MW, MX, MY, MZ, NA, NG, NI, NO, NZ, OM, PG, PH, PL, PT, RO, RS, RU, SC, SD, SE, SG, SK, SL, SM, ST, SV, SY, TJ, TM, TN, TR, TT, TZ, UA, UG, US, UZ, VC, VN, ZA, ZM, ZW.

(84) Designated States (unless otherwise indicated, for every kind of regional protection available): ARIPO (BW, GH, GM, KE, LS, MW, MZ, NA, SD, SL, SZ, TZ, UG, ZM, ZW), Eurasian (AM, AZ, BY, KG, KZ, MD, RU, TJ, TM), European (AT, BE, BG, CH, CY, CZ, DE, DK, EE, ES, FI, FR, GB, GR, HR, HU, IE, IS, IT, LT, LU, LV, MC, MK, MT, NL, NO, PL, PT, RO, SE, SI, SK, TR), OAPI (BF, BJ, CF, CG, CI, CM, GA, GN, GQ, GW, ML, MR, NE, SN, TD, TG).

Published:

— with international search report (Art. 21(3))

(54) Title: TREATMENT DEVICES WITH DELIVERY-ACTIVATED INFLATABLE MEMBERS, AND ASSOCIATED SYSTEMS AND METHODS FOR TREATING THE SPINAL CORD AND OTHER TISSUES

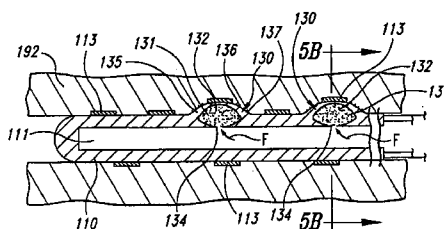

Fig. 5A

(57) Abstract: Treatment systems with delivery-activated inflatable members, and associated systems and methods for treating the spinal cord and other tissues are disclosed. A treatment system in accordance with one embodiment includes a lead body having an opening, an inner surface position around the opening, and an inflatable member carried by the lead body, with at least one of the inflatable member and the lead body including a frangible portion accessible from the opening. The inflatable member can have an expandable interior volume bounded at least in part by the frangible portion. The system can further include a delivery device received in the opening of the lead body and positioned to open a passage through the frangible portions between the interior volume of the inflatable member and the opening of the lead body when the delivery device is removed from the opening of the lead body.

WO 2009/129329 A1

TREATMENT DEVICES WITH DELIVERY-ACTIVATED
INFLATABLE MEMBERS, AND ASSOCIATED SYSTEMS AND
METHODS FOR TREATING THE SPINAL CORD AND OTHER
TISSUES

TECHNICAL FIELD

[0001] The present disclosure is directed generally to treatment devices with delivery-activated inflatable members, and associated systems and methods for treating the spinal cord and other tissues.

BACKGROUND

[0002] Neurological stimulators have been developed to treat pain, movement disorders, functional disorders, spasticity, cancer, cardiac disorders, and several other medical conditions. Implantable neurological stimulation systems generally have an implantable pulse generator and one or more electrode leads that deliver electrical pulses to neurological tissue or muscle tissue. For example, several neurological stimulation systems for spinal cord stimulation (SCS) have cylindrical leads that include a lead body with a circular cross-sectional shape and one or more conductive rings spaced apart from each other at the distal end of the lead body. The conductive rings operate as individual electrodes. In many cases, the SCS leads are implanted percutaneously through a large needle inserted into the epidural space, with or without the assistance of a stylet. One concern of such leads is that the leads may not remain in the desired position after being implanted. This is undesirable because, if the leads migrate from the initial implantation site, the stimulation provided by the electrodes may no longer be directed to the appropriate target tissue. Accordingly, the efficacy of the treatment can be significantly compromised.

[0003] Another type of stimulation lead is a paddle lead. Paddle leads typically have a relatively flat body with electrodes arranged on one side of the body. Paddle leads are commonly used for cortical stimulation and SCS applications. Large paddle leads are desirable because they cover more neurological structures and, in

at least some cases, may be more stable and less subject to migration than cylindrical leads. However, large paddle leads are not well suited to percutaneous implantation. As a result, large paddle leads are often surgically implanted using highly invasive procedures that are costly and can lead to patient complications.

BRIEF DESCRIPTION OF THE DRAWINGS

[0004] Figure 1 is a schematic diagram of an implantable spinal stimulator with a lead body positioned at the spine in accordance with an embodiment of the present disclosure.

[0005] Figure 2 is a partially schematic, cross-sectional side view of a lead body and delivery device configured in accordance with a particular embodiment of the disclosure.

[0006] Figure 3A is a partially schematic cross-sectional side view of the lead body shown in Figure 2 implanted in patient tissue in accordance with a particular embodiment of the disclosure.

[0007] Figure 3B is a partially schematic sectional view of the lead body taken substantially along line 3B-3B of Figure 3A.

[0008] Figure 4 is a partially schematic illustration of the lead body shown in Figure 3A as an associated delivery device is withdrawn in accordance with a particular embodiment of the disclosure.

[0009] Figure 5A is a partially schematic cross-sectional side view of the lead body shown in Figure 4 after inflatable members have been inflated in accordance with a particular embodiment of the disclosure.

[0010] Figure 5B is a partially schematic sectional view of the lead body taken substantially along line 5B-5B of Figure 5A.

[0011] Figure 6 is a flow diagram illustrating a process for positioning a delivery lead in accordance with a particular embodiment of the disclosure.

[0012] Figure 7 is a cross-sectional illustration of the spinal cord and adjacent tissue, illustrating representative implantation locations for lead bodies in accordance with particular embodiments of the disclosure.

[0013] Figure 8 is a flow diagram illustrating a method for manufacturing a patient treatment device in accordance with a particular embodiment of the disclosure.

[0014] Figure 9 is a partially schematic, cross-sectional side view of a lead body temporarily attached to a delivery device with an adhesive in accordance with a particular embodiment of the disclosure.

[0015] Figure 10 is a partially schematic, cross-sectional side view of a lead body temporarily attached to a delivery device with an adhesive that forms a frangible portion in accordance with a particular embodiment of the disclosure.

[0016] Figure 11 is a partially schematic, cross-sectional side view of a delivery device having a barb for piercing the frangible portion of a lead body in accordance with another embodiment of the disclosure.

DETAILED DESCRIPTION

A. Overview

[0017] Specific details of several embodiments of the disclosure are described below with reference to implantable leads for stimulating neural structures, methods for implanting leads, methods for manufacturing leads, and methods for stimulating a target neural site of a patient. Although selected embodiments are described below with respect to stimulating the dorsal root and/or neighboring regions of the spinal column to control pain, the leads may be used for stimulating the brain, peripheral neurological structures, and/or other tissue (e.g., muscle tissue). Several embodiments can have different configurations, components or procedures than those described in this section, and other embodiments may eliminate particular components or procedures. A person of ordinary skill in the relevant art, therefore, will understand that the invention may have other embodiments with additional elements, and/or may have other embodiments without several of the features shown and described below with reference to Figures 1-11.

[0018] A patient treatment system in accordance with a particular embodiment of the disclosure includes a lead body having an opening and an inner surface positioned around the opening. An inflatable member is carried by the lead body, and the inflatable member and/or the lead body include a frangible portion

accessible from the opening. The inflatable member has an expandable interior volume bounded at least in part by the frangible portion. A delivery device is received in the opening of the lead body and is positioned to open a passage through the frangible portion between the interior volume of the inflatable member and the opening of the lead body when the delivery device is removed from the opening of the lead body. Accordingly, the delivery device can be used to position the lead body at the appropriate location in a patient and then, as the delivery device is removed from the lead body, it can open up communication between the inflatable member and the opening in the lead body. The inflatable member can be filled with a self-expanding material, so that it "automatically" inflates once the frangible portion has been broken. In another arrangement, a fluid can be driven into the inflatable member via the opening to inflate or further inflate the inflatable member. The lead body can have one or more electrical contacts that provide electrical stimulation to the patient, while the inflatable member secures or assists in securing the lead body at the appropriate patient location.

[0019] A representative method for positioning a lead in a patient includes percutaneously passing a lead into the patient's body while the lead is carried by a delivery device. The lead can have an inflatable volume, and the delivery device can be received in an opening of the lead. The method can further include forming a passage between the opening of the lead and the inflatable volume by at least partially removing the delivery device from the opening. The inflatable volume can then be expanded. In particular embodiments, forming the passage between the opening in the lead and the inflatable volume can include tearing a wall between the opening and the inflatable volume as the delivery device is removed. In a particular arrangement, an adhesive connection between the lead and the delivery device is broken as the delivery device is removed. In another embodiment, the delivery device can include a barb or other sharpened member that penetrates the wall between the opening in the lead and the inflatable volume as the delivery device is removed.

[0020] Yet another aspect of the disclosure includes a method for manufacturing a patient treatment device. A representative method includes positioning a delivery device proximate to a lead body and juxtaposing the delivery device and the lead body with the delivery device located within an opening of the

lead body. The delivery device is positioned so that removing the delivery device from the opening forms a fluid passage between the opening and an interior volume of an expandable member carried by the lead body. The lead body can accordingly be adhered to the delivery device in one arrangement. The expandable member can be collapsed and/or evacuated prior to being attached to the delivery device, or it (along with an interior self-expanding material) can be collapsed around the delivery device while the delivery device is positioned within the lead body.

B. Embodiments of Implantable Neural Stimulation Systems and Associated Methods

[0021] Figure 1 schematically illustrates a representative treatment system 100 for providing relief from chronic pain and/or other conditions, arranged relative to the general anatomy of a patient's spinal cord 191. The system 100 can include a pulse generator 101 implanted subcutaneously within the patient 190 and coupled to a lead 109. The lead 109 can include a lead body 110 that carries features for delivering therapy to the patient 190 and resisting the ability of the lead body 110 to move relative to the patient 190 after implantation. The pulse generator 101 can be connected directly to the lead body 110 or it can be coupled to the lead body 110 via a communication link 102. As used herein, the term lead body includes any of a number of suitable substrates and/or support members that carry devices for providing therapy signals to the patient 190. For example, the lead body 110 can include one or more electrodes or electrical contacts that direct electrical signals into the patient's tissue to provide for patient relief. In other embodiments, the lead body 110 can carry other devices that direct electrical and/or other types of signals to the patient.

[0022] The pulse generator 101 can transmit signals to the lead body 110 that up-regulate (e.g., stimulate) and/or down-regulate (e.g., block) target nerves. Accordingly, the pulse generator 101 can include a computer-readable medium containing instructions for generating and transmitting suitable therapy signals. The pulse generator 101 and/or other elements of the system 100 can include one or more processors, memories, and/or input/output devices. The pulse generator 101 can include multiple portions, e.g., for directing signals in accordance with multiple signal delivery parameters, housed in a single housing (as shown in Figure 1), or in multiple housings. Representative signal delivery parameters are disclosed in

pending U.S. Provisional Application No. 60/985,353, filed November 5, 2007, assigned to the assignee of the present application, and incorporated herein by reference.

[0023] In some embodiments, the pulse generator 101 can obtain power to generate the therapy signals from an external power source 103. The external power source 103 can transmit power to the implanted pulse generator 101 using electromagnetic induction (e.g., RF signals). For example, the external power source 103 can include an external coil 104 that communicates with a corresponding internal coil (not shown) within the implantable pulse generator 101. The external power source 103 can be portable for ease of use.

[0024] In another embodiment, the pulse generator 101 can obtain the power to generate therapy signals from an internal power source. For example, the implanted pulse generator 101 can include a non-rechargeable battery or a rechargeable battery to provide such power. When the internal power source includes a rechargeable battery, the external power source 103 can be used to recharge the battery. The external power source 103 can in turn be recharged from a suitable power source (e.g., conventional wall power).

[0025] In still further embodiments, an external programmer (not shown) can communicate with the implantable pulse generator 101 via electromagnetic induction. Accordingly, a practitioner can update the therapy instructions provided by the pulse generator 101. Optionally, the patient may also have control over at least some therapy functions, e.g., starting and/or stopping the pulse generator 101.

[0026] Figure 2 is a partially schematic, cross-sectional side view of a portion of the system 100 described above with reference to Figure 1, including the lead body 110 temporarily carried by a delivery device 120. The lead body 110 can be elongated along an axis A and can have an opening 111 that receives the delivery device 120. The delivery device 120 can accordingly include a stylet, guidewire, and/or other suitable device that is releasably positioned within the opening 111. The lead body 110 can have a generally annular arrangement with an inner surface 112 bounding the opening 111, and an outer surface 114 facing outwardly from the inner surface 112. The lead body 110 can carry one or more electrodes 113 at the outer surface 114, and one or more wires 115 or other suitable links can provide a

signal path by which therapy signals are directed from the pulse generator 101 (Figure 1) to the electrodes or electrical contacts 113. The lead body 110 can be formed from any of a variety of known, suitable, biocompatible, and generally insulating materials, e.g., biocompatible plastics. The electrical contacts 113 can be formed from any of a variety of known, suitable, biocompatible and generally conductive materials, e.g., palladium, iridium, stainless steel, titanium or platinum.

[0027] The system 100 can further include one or more inflatable and/or expandable members 130 (two are shown in solid lines in Figure 2 for purposes of illustration) carried by the lead body 110. The inflatable members 130 can be formed from a suitable, biocompatible, balloon-type material, and can be made integral with the lead body 110 or formed separately and attached to the lead body 110. The material forming the inflatable member 130 can be elastic in some embodiments and generally inelastic (though still flexible enough to collapse and expand) in others. Individual inflatable members 130 can include an interior volume 131 bounded at least in part by an outwardly facing exterior portion 135, and an inwardly facing frangible portion 133 that faces toward the delivery device 120. In some cases, the interior volume 131 can be empty and in other cases the interior volume 131 can be filled with a self-inflating material 132 (e.g., an open-cell foam or other suitable material). Suitable materials can include biocompatible foams that are generally similar in physical properties to the open-cell foams used in camping mattresses. In either of these embodiments, the interior volume 131 can have a collapsed state (shown in Figure 2) and an expanded state (described further below with reference to Figures 5A and 5B). When the lead body 110 is carried by the delivery device 120 and placed percutaneously in the patient, the inflatable members 130 are generally collapsed to reduce the diameter of the lead body 110 and therefore ease its entry into the patient. The inflatable members 130 can be axially aligned with corresponding electrodes 113, as shown in solid lines in Figure 2, and/or one or more inflatable members 130 can be axially offset from corresponding electrodes 113, as shown in dashed lines in Figure 2.

[0028] Figure 3A schematically illustrates the lead body 110 and the delivery device 120 after both have been inserted as a unit into patient tissue 192. Arrow P indicates the insertion direction. As shown in Figure 3A, the inflatable members 130 remain collapsed during this process.

[0029] Figure 3B is a partially schematic, sectional view of the delivery device 120 and the lead body 110, taken substantially along line 3B-3B of Figure 3A. As shown in this view, the frangible portion 133 can be relatively thin and/or weak when compared to the exterior portion 135 of the inflatable member 130 located outwardly from the interior volume 131. In a particular arrangement, the frangible portion 133 can be the weakest portion of the inflatable member 130. In any of the foregoing embodiments, and as described further below, the frangible portion 133 can be positioned and configured to be broken, disrupted, penetrated, and/or otherwise opened as the delivery device 120 is withdrawn.

[0030] Figure 4 is a cross-sectional illustration of the lead body 110 as the delivery device 120 is being withdrawn from the opening 111 in which it is received. During the withdrawal process, the practitioner can hold the proximal end of the lead body 110 (which, at this point, extends outside the patient's body) in place, while withdrawing the delivery device 120. As the delivery device 120 is withdrawn (indicated by arrow W), the action of withdrawing the delivery device 120 can open up passages 134 between individual interior volumes 131 and the central opening 111 in the lead body 110. For example, as will be discussed in greater detail later with reference to Figures 9-11, each of the frangible portions 133 may be attached to the delivery device 120 with a volume of adhesive material. As the delivery device 120 is withdrawn, the relative motion between the delivery device 120 and the lead body 110 tears an opening in the frangible portion 133, allowing for fluid communication between the opening 111 in the lead body 110 and the interior volumes 131 of individual inflatable members 130. The inflatable members 130 can then be inflated, expanded, and/or otherwise increased in size and/or changed in shape, as described below with reference to Figures 5A and 5B.

[0031] Figure 5A is a side cross-sectional illustration of the lead body 110 after the delivery device 120 (Figure 4) has been removed. The open passages 134 between the interior volumes 131 of individual inflatable members 130 and the opening 111 within the lead body 110 allow for a flow of fluid into the interior volumes 131, as indicated by arrows F. When the interior volumes 131 include a self-inflating material 132, the expansion of the self-inflating material 132 can draw fluid into the interior volumes 131 to further support the expanded shape of the inflatable members 130 shown in Figure 5A. For example, if the opening 111 of the lead body

110 is in communication with bodily fluids in the patient tissue 192, such fluids can be drawn into the inflatable members 130 by the expanding action of the self-inflating material 132. In another embodiment, a practitioner can specifically direct fluids into the interior volumes 131 via the opening 111 in the lead body 110 and the passages 134. For example, the practitioner can direct a liquid, gas, foam, gel, or other flowable material into the interior volume 131 using a syringe or other suitable fluid delivery device. In a particular embodiment, the fluid directed into the inflatable members 130 can include an adhesive or other material that hardens once inside the inflatable members 130 to further solidify the expanded shape of the inflatable members 130. The fluid can be directed into the inflatable members 130 to supplement the action of the self-inflating material 132, or, (e.g., if the inflatable members 130 do not include a self-inflating material 132), the directed fluid alone can expand the inflatable members 130.

[0032] Figure 5B is a partially schematic, sectional view of the lead body 110 taken substantially along line 5B-5B of Figure 5A, and illustrates one of the inflatable members 130 in its inflated or otherwise expanded state. Referring to Figures 5A and 5B together, the inflatable members 130 in the expanded state can fix, secure, and/or otherwise at least partially restrict relative movement between the lead body 110 and the patient tissue 192 by projecting outwardly from the main contour of the lead body 110 and against the patient tissue 192. In a particular embodiment, the ability of the inflatable members 130 to secure the lead body 110 to the patient tissue 192 can be enhanced by roughness elements 136 positioned at an exterior surface 137 of the inflatable members 130. In other embodiments, the roughness elements 136 may be eliminated.

[0033] The degree (if any) to which the inflatable members 130 apply a force to the patient tissue 192 can be selected depending upon the characteristics of the particular implantation site. For example, if the inflatable members 130 carry electrodes 113 and are positioned so that the electrodes 113 contact target neural sites (e.g., neurons), then it may be desirable to arrange the inflatable members 130 so that the electrodes 113 touch and/or mate with the adjacent tissue, but do not apply a significant force to the adjacent tissue, so as to avoid creating a patient sensation and/or other potentially undesirable side effect. In another embodiment, for example, if the electrodes 113 are spaced apart from the inflatable members

130, the inflatable members 130 can apply some force to the tissue 192 to secure the lead body 110 in position. For example, if the inflatable members 130 bear against bony tissue or other tissue that is less sensitive than neural tissue, it may be acceptable to both patient and practitioner to have the inflatable members 130 apply some (e.g., low level) force to the tissue.

[0034] Figure 6 is a flow diagram illustrating a process 600 for positioning a lead in a patient. The process 600 can include percutaneously passing a lead into the patient's body while the lead is carried by a delivery device (process portion 602). The lead includes an inflatable volume and the delivery device is received in an opening of the lead. Process portion 604 includes forming a passage between the opening in the lead and the inflatable volume by at least partially removing the delivery device from the opening. For example, the passage can be formed when an adhesive connection between the lead and the delivery device is broken or otherwise disturbed. In process portion 606, the inflatable volume is expanded, for example, via a self-inflating material and/or an actively delivered fluid. Once the lead is in place, the implantable pulse generator (Figure 1) can be activated to deliver therapeutic signals to the patient via electrodes carried by the lead.

[0035] Figure 7 is a cross-sectional illustration of the spinal cord 191 and an adjacent vertebra 195, along with selected representative locations for representative lead bodies 110 (shown as lead bodies 110a-110c) in accordance with several embodiments of the disclosure. The spinal cord 191 is located between a ventrally located vertebral body 196 and the dorsally located transverse process 198 and spinous process 197. Arrows V and D identify ventral and dorsal directions, respectively. The spinal cord itself 191 is located within the dura mater 199, which also surrounds portions of the nerves exiting the spinal cord 191, including the dorsal roots 193 and dorsal root ganglia 194. In a particular embodiment, a lead body 110a can be positioned centrally in a lateral direction (e.g., aligned with the spinal cord midline 189) to provide signals directly to the spinal cord 191. In other embodiments, the lead body can be located laterally from the midline 189. For example, the lead body can be positioned proximate to the dorsal root 193 (as indicated by lead body 110b) and/or proximate to the dorsal root ganglion 194 (as indicated by lead body 110c). Other suitable locations for the lead body 110 include the "gutter," also located laterally from the midline 189, and the dorsal root entry

zone. In still further embodiments, the lead bodies may have other locations proximate to the spinal cord 191 and/or proximate to other target neural populations e.g., laterally from the midline 189 and medially from the dorsal root ganglion 194. In yet further embodiments, devices having any of the characteristics described herein may be used to direct signals (e.g., electrical current) to tissues outside the patient's nervous system.

[0036] Figure 8 is a flow diagram illustrating a process 800 for manufacturing a treatment system in accordance with a particular embodiment. The process 800 can include positioning a delivery device proximate to a lead body (process portion 802) and juxtaposing the delivery device and the lead body with the delivery device located within an opening of the lead body (process portion 804). The delivery device and the lead body are juxtaposed so that removal of the delivery device from the opening forms a fluid passage between the opening and an interior volume of an expandable member carried by the lead body. Further details of representative processes are described below with reference to Figures 9-11.

[0037] Figure 9 illustrates the lead body 110 attached to the delivery device 120 with one or more adhesive volumes 121 (two are shown in Figure 9), in accordance with a particular embodiment. In one aspect of this embodiment, the inflatable members 130 can be pre-evacuated so as to assume the collapsed shape shown in Figure 9. With the inflatable members 130 in the collapsed configuration, the delivery device 120 can be inserted into the opening 111. The adhesive volumes 121 can be applied to the delivery device 120 and/or the lead body 110 prior to insertion. In a particular arrangement, the delivery device 120 can include recesses in which the adhesive volumes 121 are positioned, so as to avoid smearing the adhesive over the inner surface 112 of the lead body 110. In another embodiment, a recess can be located in the frangible portion 133 of the lead body 110, in addition to or in lieu of a recess located in the delivery device 120. In any of these embodiments, the adhesive volumes 121 can be allowed to set, cure or partially cure once the delivery device 120 is inserted to the desired location. When the lead body 110 and the delivery device 120 are inserted together into the patient, the adhesive volumes 121 can maintain the lead body 110 in a fixed position relative to the delivery device 120. When the delivery device 120 is then withdrawn, the adhesive volumes 121 can tear the frangible portions 133 and create the passages 134

described above. The inflatable members 130 then inflate, autonomously and/or via active fluid delivery, to secure or at least partially secure the lead body 110 in position.

[0038] Figure 10 schematically illustrates another arrangement for temporarily attaching the lead body 110 to the delivery device 120. In this arrangement, the delivery device 120 can be inserted into the lead body 110 while the inflatable members 130 are in the inflated state, as indicated in dashed lines in Figure 10. An adhesive 121 can be positioned at the appropriate locations on the delivery device 120 and/or the inflatable members 130 prior to insertion. When the lead body 110 has the correct axial position relative to the delivery device 120, the inflatable members 130 can be compressed, as indicated by arrows C to both collapse the inflatable members 130 and adhere the lead body 110 to the delivery device 120. The lead body 110 can then be percutaneously delivered into the patient, and the delivery device 120 can be withdrawn in a manner generally similar to that discussed above with reference to Figure 9.

[0039] In one aspect of the arrangement described above with reference to Figure 10, the inflatable members 130 include a pre-formed frangible portion 133, generally similar to the frangible portions shown in Figures 2-3B. In another embodiment, the adhesive 121 itself can form the frangible portion 133. In other words, the inflatable volumes 130 can initially have interior volumes 131 that open inwardly toward the delivery device 120. When the lead body 110 is attached to the delivery device 120, the adhesive 121 seals the interior volumes 131. When the delivery device 120 is later withdrawn (after the lead body 110 is implanted), the adhesive 121 disbonds or otherwise fails, forming the passages that allow the inflatable volumes 130 to inflate.

[0040] Figure 11 illustrates still another embodiment in which the delivery device 120 includes a barb or other sharpened element 122 that can puncture, penetrate, and/or otherwise disturb the frangible portion 133. In one aspect of this embodiment, the delivery device 120 can be slid into the opening 111 in the lead body 110 from right to left, without the element 122 disturbing the frangible portions 133. Accordingly, the element can face proximally (e.g., to the right in Figure 11). As the delivery device 120 is withdrawn from the lead body 110, the element 122 can puncture the frangible portions 133, allowing the inflatable members 130 to

inflate and/or be inflated. The material of the lead body 110 can be thick enough to withstand any scoring that may be produced by the element 122 as it passes along other portions of the inner surface 112 (aside from the frangible portion 133), without compromising the integrity of the lead body 110. The element 122 can include one or more barbs, or other puncturing or hole-creating structures, e.g., a sharp-edged, rightward facing cup.

[0041] One feature of at least some of the foregoing embodiments is that the lead body can include one or more inflatable or otherwise expandable members having frangible portions that are opened as the associated delivery device is removed from the lead body. An advantage of this arrangement is that it can allow the inflatable member to have a collapsed (e.g., low-profile) shape as it is delivered into the patient's body, and an expanded shape (e.g., one that can secure the lead body in position) once the delivery tool has been removed. In particular embodiments, the inflatable member can assume the expanded shape automatically, e.g., when the inflatable member includes a self-inflating material and when the frangible portion is disrupted such that fluid can fill or at least partially fill the self-inflating material during inflation. This particular arrangement can reduce the number of tasks a practitioner performs when fixing or at least partially fixing the lead body in position in the patient's body. Another expected advantage of this particular arrangement is that the self-inflating material does not require continuous fluid pressure for the inflatable member to retain its expanded shape. Accordingly, the practitioner need not seal the inflatable member after it has expanded, and, if the inflatable member develops a leak (e.g., at its exterior surface), it can still retain its expanded shape.

[0042] From the foregoing, it will be appreciated that specific embodiments of the disclosure have been described herein for purposes of illustration, but that various modifications may be made without deviating from the disclosure. For example, the lead bodies may have arrangements other than those specifically shown and discussed above, including flatter or otherwise non-isodiametric cross-sectional shapes. As noted above, the lead body can be connected directly to an implanted pulse generator, or an additional signal communication link can be connected between the lead body and the implanted pulse generator. The lead body can include any of a variety of support structures that carry the appropriate

signal delivery elements. Such elements can include electrical contacts, as discussed above, or other elements (e.g., ultrasonic or optical elements). Any of these elements may be carried by the inflatable member(s) and/or by other portions of the lead body. The inflatable members can extend around a portion of the perimeter of the lead body (as shown in Figures 3B and 5B) or around the entire perimeter at a given axial location. In other embodiments, one inflatable member at one axial location can have one circumferential position (e.g., centered at a 12:00 position) and another inflatable member can have another circumferential position (e.g., centered at a 6:00 position).

[0043] Certain aspects of the disclosure described in the context of particular embodiments may be combined or eliminated in other embodiments. For example, the barb or other sharpened element described above with reference to Figure 11 may be combined with the adhesive described with reference to previous figures. Further, while advantages associated with certain embodiments have been described in the context of those embodiments, other embodiments may also exhibit such advantages, and not all embodiments need necessarily exhibit such advantages to fall within the scope of the invention. Accordingly, the disclosure can include other embodiments not expressly shown or described above.

CLAIMS

I/We claim:

1. A patient treatment system, comprising:
a lead body having an opening and an inner surface positioned around the opening;
an inflatable member carried by the lead body, with at least one of the inflatable member and the lead body including a frangible portion accessible from the opening, the inflatable member having an expandable interior volume bounded at least in part by the frangible portion; and
a delivery device received in the opening of the lead body, the delivery device being positioned to open a passage through the frangible portion between the interior volume of the inflatable member and the opening of the lead body when the delivery device is removed from the opening of the lead body.
2. The treatment system of claim 1 wherein the frangible portion is adhesively coupled to the delivery device.
3. The treatment system of claim 1 wherein the delivery device includes a sharp element positioned to puncture the frangible portion as the delivery device is withdrawn from the opening of the lead body.
4. The treatment system of claim 1 wherein the lead body is elongated along an axis and wherein the opening is aligned along the axis.
5. The treatment system of claim 1 wherein an exterior surface of the inflatable body includes roughness elements positioned to contact and engage with adjacent patient tissue.

6. The treatment system of claim 1 wherein the inflatable member is one of multiple inflatable members carried by the lead body.

7. The treatment system of claim 1, further comprising a self-inflating material positioned in the interior volume of the inflatable member.

8. The treatment system of claim 1 wherein the lead body and the inflatable member form a unitary structure.

9. The treatment system of claim 1 wherein the self-inflating material is evacuated while the delivery device is received in the opening of the lead body and the frangible portion is closed.

10. The treatment system of claim 1, further comprising at least one electrical contact carried by the inflatable member and movable with the inflatable member as the inflatable member changes between an inflated and deflated configuration.

11. The treatment system of claim 1, further comprising at least one electrical contact carried by the lead body and spaced apart from the inflatable member.

12. A patient treatment system, comprising:
a lead body having an opening and an inner surface positioned around the opening;
an inflatable member carried by the lead body, with at least one of the inflatable member and the lead body including a frangible portion accessible from the opening, the inflatable member having an expandable interior volume bounded at least in part by the frangible portion; and
an electrical contact carried by the inflatable member.

13. The treatment system of claim 12, further comprising a delivery device slideably received in the opening of the lead body.

14. The treatment system of claim 12 wherein the inflatable member includes an exterior surface carrying the electrical contact, and wherein the frangible portion is structurally weaker than the exterior surface, and wherein the system further includes a self-inflating material in the interior volume.

15. The treatment system of claim 12 wherein the frangible portion is the weakest portion of the inflatable member.

16. A method for positioning a delivery lead in a patient, comprising:
percutaneously passing a lead into the patient's body while the lead is carried by a delivery device, the lead having an inflatable volume, the delivery device being received in an opening of the lead;
forming a passage between the opening in the lead and the inflatable volume by at least partially removing the delivery device from the opening; and
expanding the inflatable volume.

17. The method of claim 16 wherein forming a passage includes tearing a wall between the opening in the lead and the inflatable volume by at least partially removing the delivery device from the opening.

18. The method of claim 16 wherein expanding the inflatable volume includes directing a flowable material into the opening and through the passage into the inflatable volume.

19. The method of claim 18 wherein expanding the inflatable volume includes directing a liquid into the inflatable volume.

20. The method of claim 18 wherein expanding the inflatable member includes directing at least one of a gas, a foam, a liquid, a gel, and a curable material into the inflatable volume.

21. The method of claim 16 wherein expanding the inflatable volume includes allowing a self-expanding material within the inflatable volume to expand after the passage has been formed.

22. The method of claim 16 wherein forming a passage includes puncturing a material bounding the inflatable volume.

23. The method of claim 16 wherein forming a passage includes disrupting an adhesive between the lead and the delivery device.

24. The method of claim 16 wherein expanding the inflatable member includes positioning the inflatable member against adjacent tissue to at least restrict motion between the treatment lead and the tissue.

25. The method of claim 24 wherein positioning the inflatable member against adjacent tissue includes positioning the inflatable member against bone tissue.

26. The method of claim 24 wherein the inflatable member carries an electrical contact, and wherein positioning the inflatable member against the adjacent tissue includes positioning the electrical contact against the adjacent tissue.

27. The method of claim 16 wherein the lead body has an electrical contact, and wherein passing the lead into the patient's body includes positioning the electrical contact in electrical communication with neurons in a spinal cord region of the patient.

28. The method of claim 27 wherein the neurons include spinal cord neurons.

29. The method of claim 27 wherein the neurons include dorsal root neurons.

30. The method of claim 27 wherein passing the lead into the patient's body includes positioning the lead in a gutter along the spinal cord.

31. The method of claim 27 wherein passing the lead into the patient's body includes positioning the lead in a dorsal root entry zone.

32. A method for manufacturing a patient treatment system, comprising:

positioning a delivery device proximate to a lead body; and
juxtaposing the delivery device and the lead body with the delivery device located within an opening of a lead body, so that removal of the delivery device from the opening forms a fluid passage between the opening and an interior volume of an expandable member carried by the lead body.

33. The method of claim 32 wherein juxtaposing includes positioning a frangible portion of the lead body adjacent to the delivery device.

34. The method of claim 32, further comprising adhering the lead body to the delivery device.

35. The method of claim 32, further comprising collapsing the expandable member around the delivery device.

36. The method of claim 35, further comprising collapsing the self-expanding material within the expandable member as the expandable member is collapsed around the delivery device.

37. The method of claim 35, further comprising evacuating the expandable member prior to inserting delivery device in the lead body.

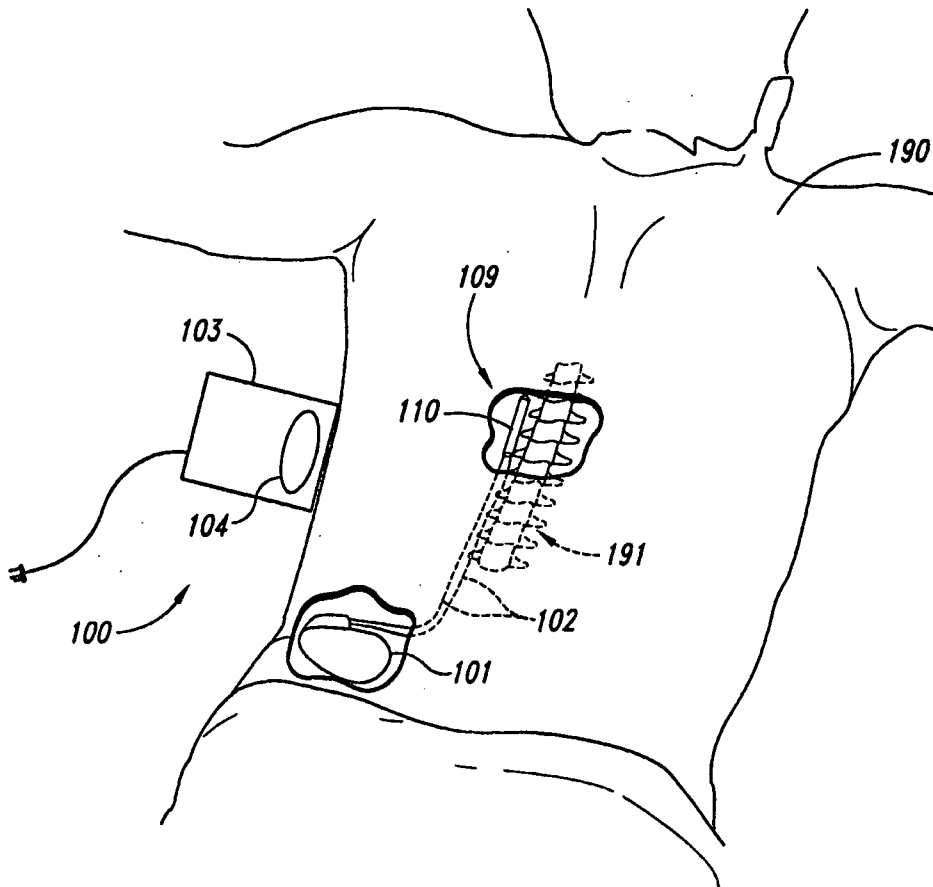

Fig. 1

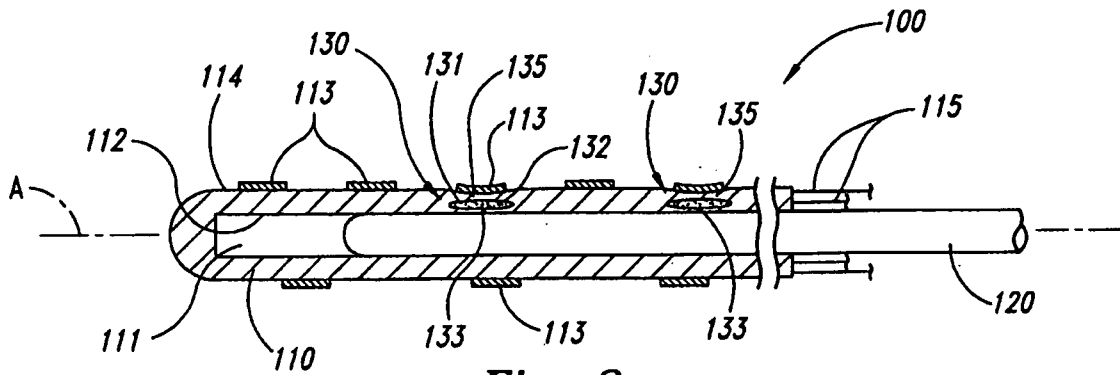

Fig. 2

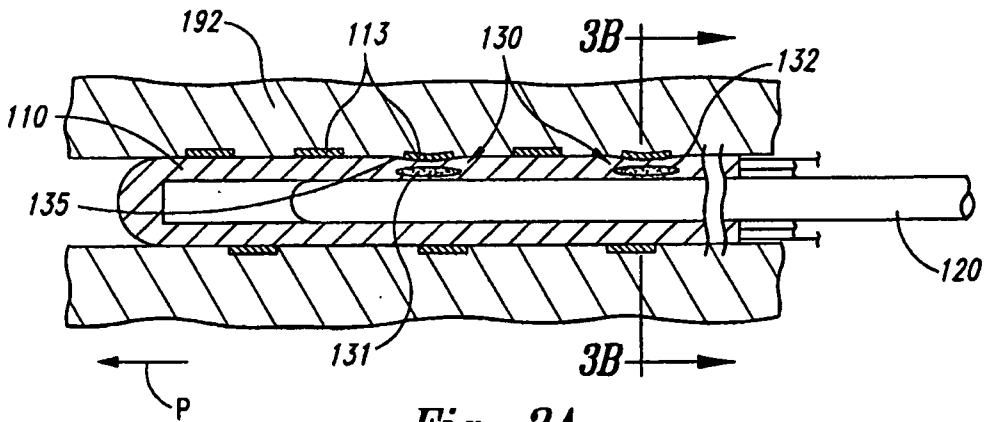

Fig. 3A

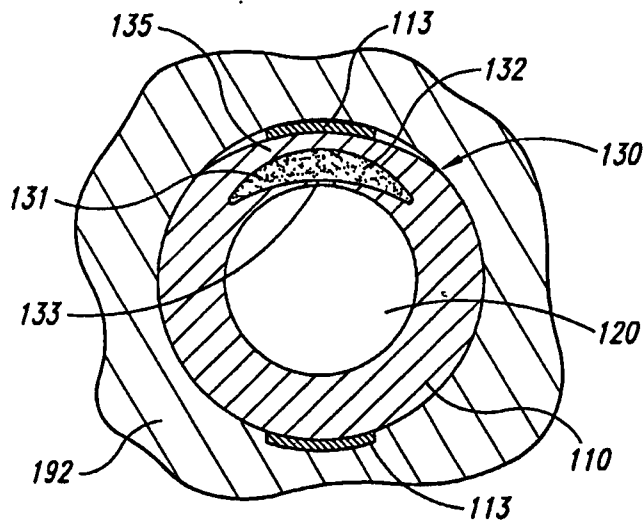

Fig. 3B

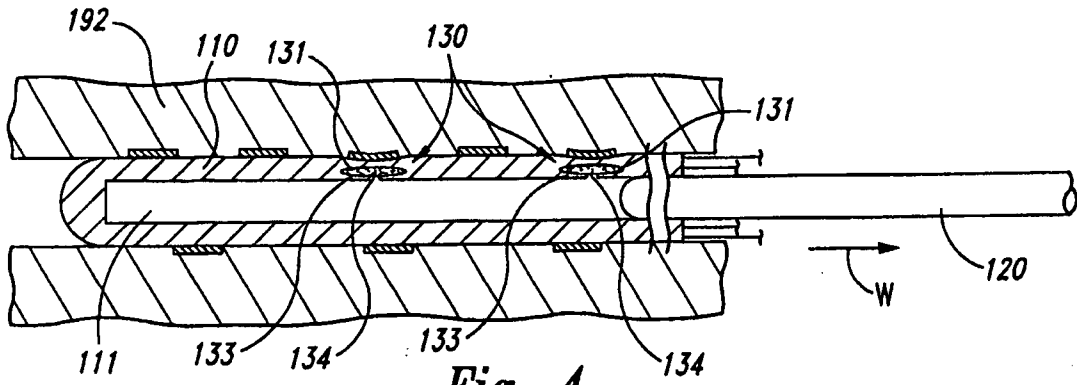

Fig. 4

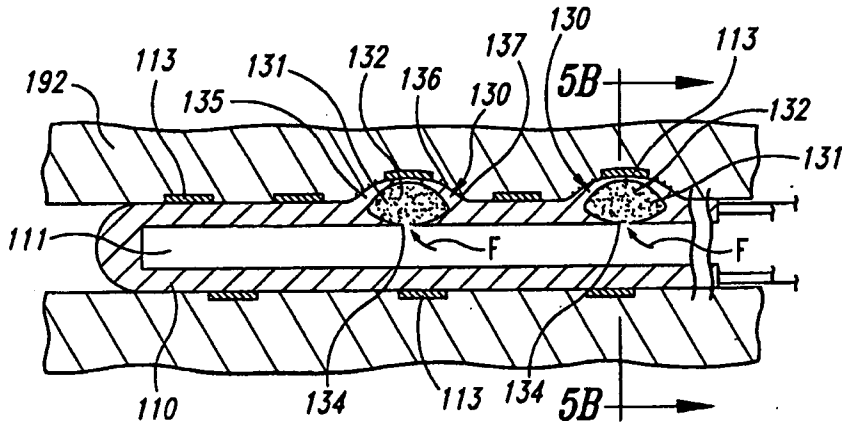

Fig. 5A

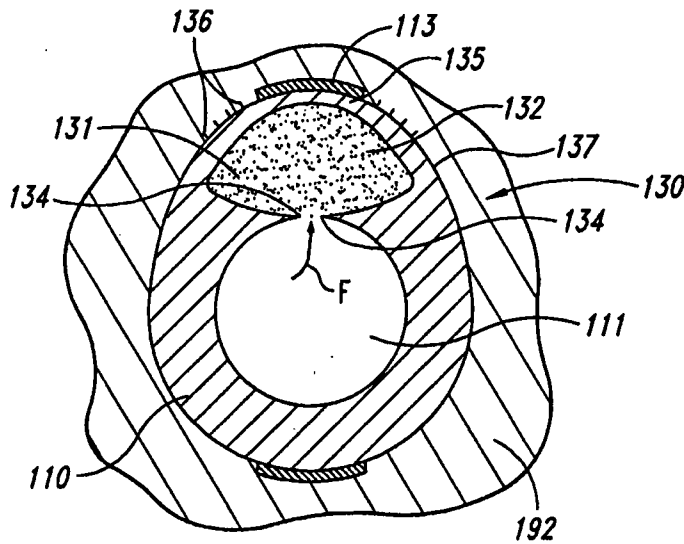

Fig. 5B

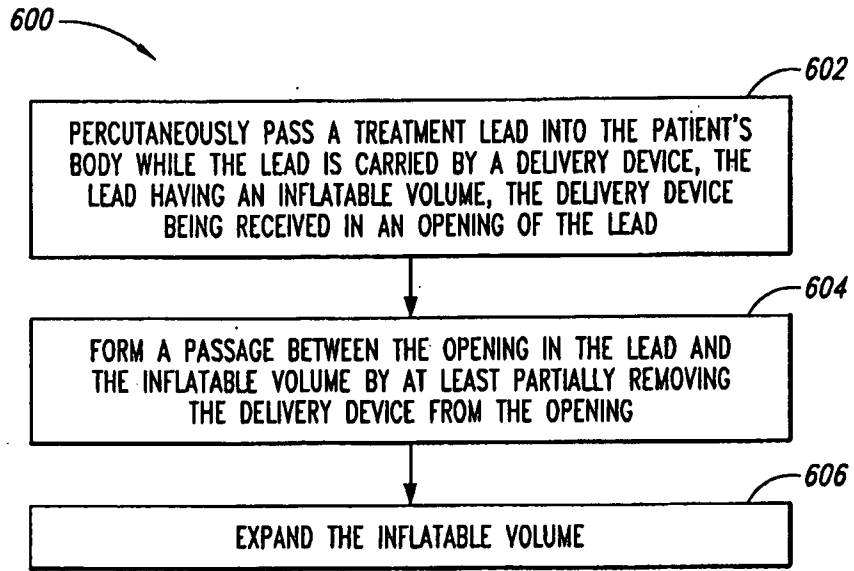

Fig. 6

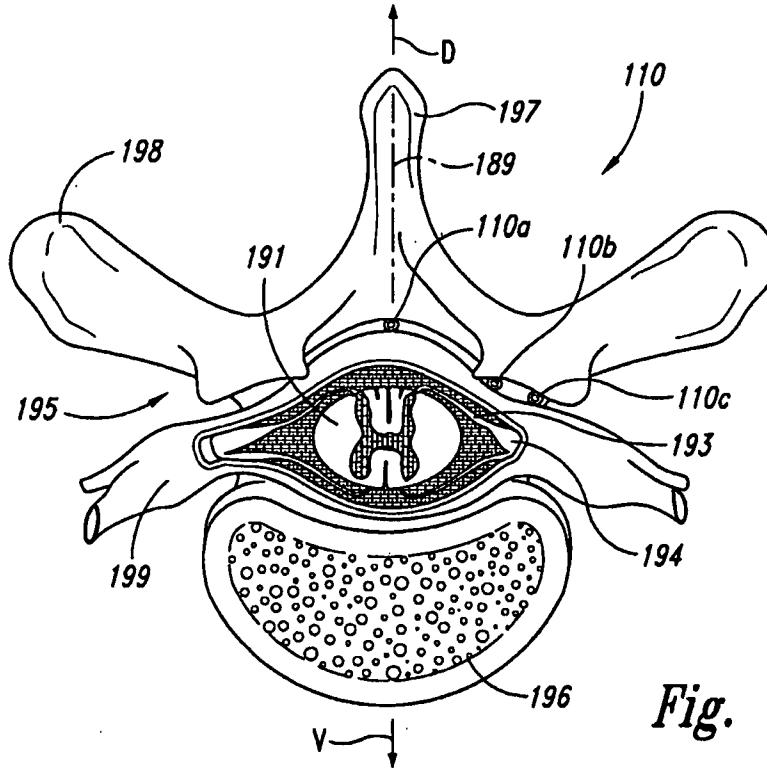

Fig. 7

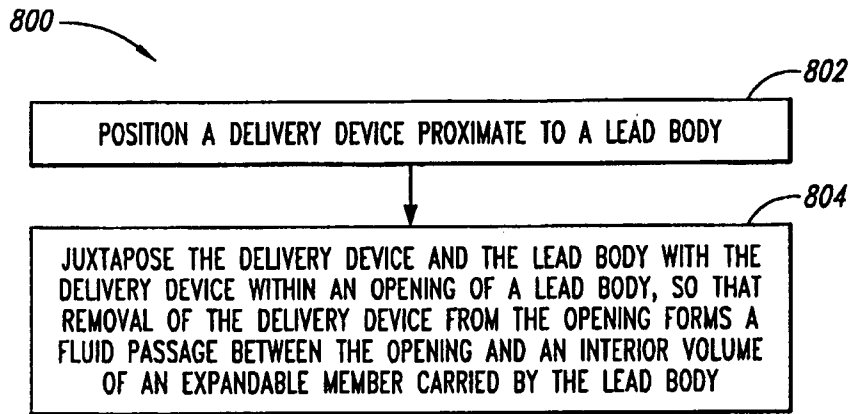

Fig. 8

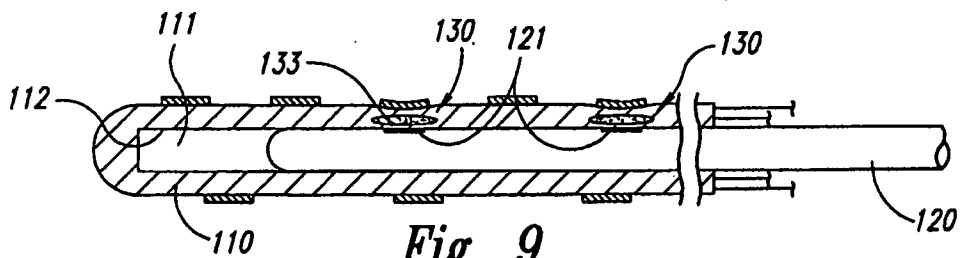

Fig. 9

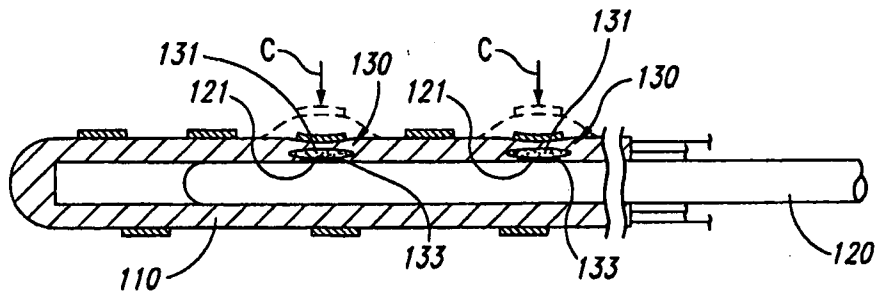

Fig. 10

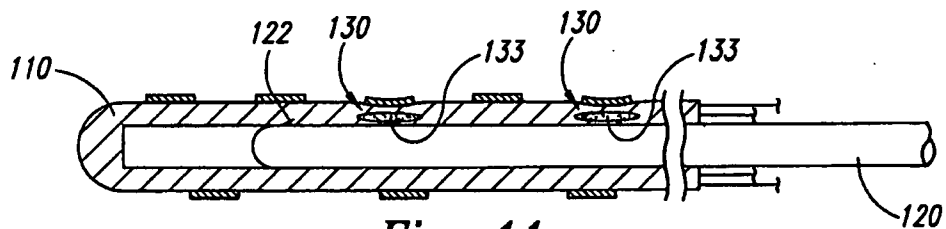

Fig. 11

INTERNATIONAL SEARCH REPORT

International application No.
PCT/US2009/040700

A. CLASSIFICATION OF SUBJECT MATTER IPC(8) - A61N 1/05 (2009.01) USPC - 607/117 According to International Patent Classification (IPC) or to both national classification and IPC				
B. FIELDS SEARCHED Minimum documentation searched (classification system followed by classification symbols) IPC(8) - A61N 1/05 (2009.01) USPC - 607/2, 46, 116, 117 Documentation searched other than minimum documentation to the extent that such documents are included in the fields searched Electronic data base consulted during the international search (name of data base and, where practicable, search terms used) PatBase				
C. DOCUMENTS CONSIDERED TO BE RELEVANT				
Category*	Citation of document, with indication, where appropriate, of the relevant passages	Relevant to claim No.		
Y	US 2008/0027505 A1 (LEVIN et al) 31 January 2008 (31.01.2008) entire document	16, 18-21, 24-32, 35-37		
Y	US 6,325,778 B1 (ZADNO-AZIZI et al) 04 December 2001 (04.12.2001) entire document	16, 18-21, 24-32, 35-37		
Y	US 5,549,662 A (FORDENBACHER) 27 August 1996 (27.08.1996) entire document	21, 36		
Y	US 7,099,718 B1 (THACKER et al) 29 August 2006 (29.08.2006) entire document	25, 27-31		
<input type="checkbox"/> Further documents are listed in the continuation of Box C.				
<table style="width: 100%; border: none;"> <tr> <td style="width: 50%; border: none;"> * Special categories of cited documents: "A" document defining the general state of the art which is not considered to be of particular relevance "E" earlier application or patent but published on or after the international filing date "L" document which may throw doubts on priority claim(s) or which is cited to establish the publication date of another citation or other special reason (as specified) "O" document referring to an oral disclosure, use, exhibition or other means "P" document published prior to the international filing date but later than the priority date claimed </td> <td style="width: 50%; border: none;"> "T" later document published after the international filing date or priority date and not in conflict with the application but cited to understand the principle or theory underlying the invention "X" document of particular relevance; the claimed invention cannot be considered novel or cannot be considered to involve an inventive step when the document is taken alone "Y" document of particular relevance; the claimed invention cannot be considered to involve an inventive step when the document is combined with one or more other such documents, such combination being obvious to a person skilled in the art "&" document member of the same patent family </td> </tr> </table>			* Special categories of cited documents: "A" document defining the general state of the art which is not considered to be of particular relevance "E" earlier application or patent but published on or after the international filing date "L" document which may throw doubts on priority claim(s) or which is cited to establish the publication date of another citation or other special reason (as specified) "O" document referring to an oral disclosure, use, exhibition or other means "P" document published prior to the international filing date but later than the priority date claimed	"T" later document published after the international filing date or priority date and not in conflict with the application but cited to understand the principle or theory underlying the invention "X" document of particular relevance; the claimed invention cannot be considered novel or cannot be considered to involve an inventive step when the document is taken alone "Y" document of particular relevance; the claimed invention cannot be considered to involve an inventive step when the document is combined with one or more other such documents, such combination being obvious to a person skilled in the art "&" document member of the same patent family
* Special categories of cited documents: "A" document defining the general state of the art which is not considered to be of particular relevance "E" earlier application or patent but published on or after the international filing date "L" document which may throw doubts on priority claim(s) or which is cited to establish the publication date of another citation or other special reason (as specified) "O" document referring to an oral disclosure, use, exhibition or other means "P" document published prior to the international filing date but later than the priority date claimed	"T" later document published after the international filing date or priority date and not in conflict with the application but cited to understand the principle or theory underlying the invention "X" document of particular relevance; the claimed invention cannot be considered novel or cannot be considered to involve an inventive step when the document is taken alone "Y" document of particular relevance; the claimed invention cannot be considered to involve an inventive step when the document is combined with one or more other such documents, such combination being obvious to a person skilled in the art "&" document member of the same patent family			
Date of the actual completion of the international search 29 May 2009	Date of mailing of the international search report 09 JUN 2009			
Name and mailing address of the ISA/US Mail Stop PCT, Attn: ISA/US, Commissioner for Patents P.O. Box 1450, Alexandria, Virginia 22313-1450 Facsimile No. 571-273-3201	Authorized officer: Blaine R. Copenheaver PCT Helpdesk: 571-272-4300 PCT OSP: 571-272-7774			