

A. WÜNSCHE.
 SEARCH LIGHT PROJECTILE.
 APPLICATION FILED MAY 17, 1911.

1,011,002.

Patented Dec. 5, 1911.

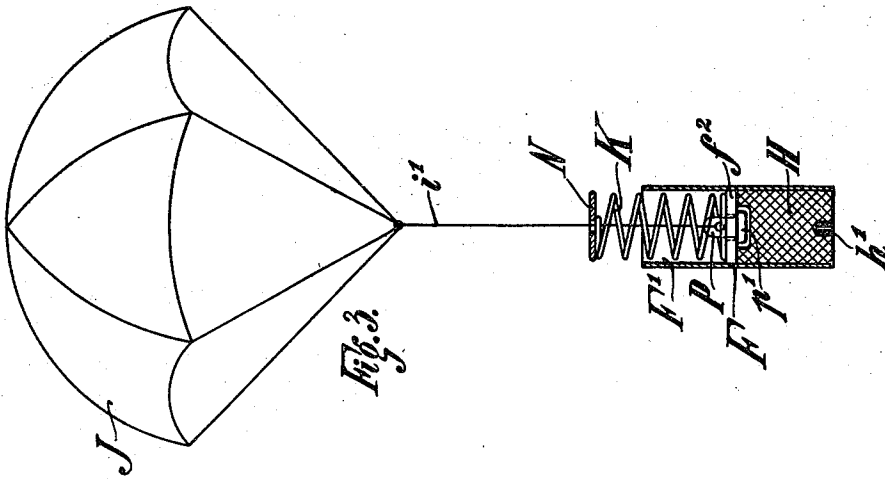

Fig. 3.

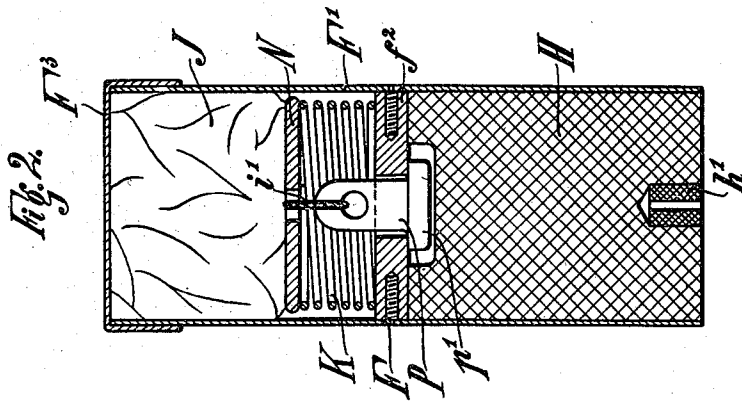

Fig. 2.

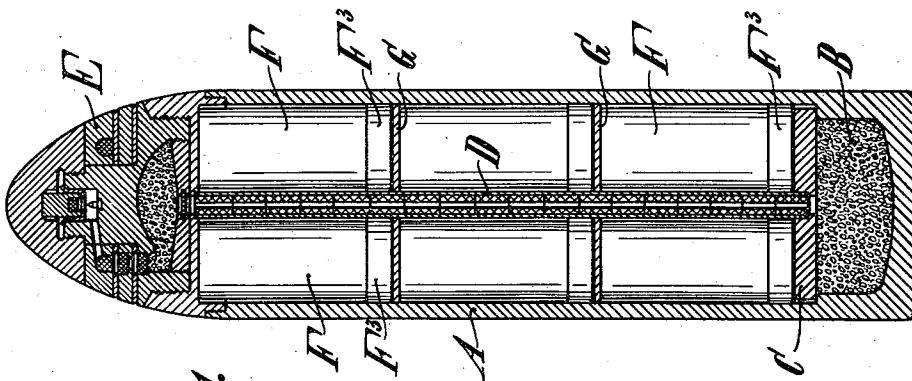

Fig. 1.

Witnesses
 J. M. Wynkoop.
 Edw. Stanley.

Inventor,
 Adolf Wünsche
 By Knights
 Attorneys.

UNITED STATES PATENT OFFICE.

ADOLF WÜNSCHE, OF BERGE-RORBECK, GERMANY, ASSIGNOR TO FRIED. KRUPP
AKTIENGESELLSCHAFT, OF ESSEN-ON-THE-RUHR, GERMANY.

SEARCH-LIGHT PROJECTILE.

1,011,002.

Specification of Letters Patent.

Patented Dec. 5, 1911.

Application filed May 17, 1911. Serial No. 627,698.

To all whom it may concern:

Be it known that I, ADOLF WÜNSCHE, a subject of the Emperor of Germany, and a resident of Berge-Rorbeck, Germany, have invented certain new and useful Improvements in Search-Light Projectiles, of which the following is a specification.

The present invention relates to search light projectiles that are provided with parachutes, and the object of the invention is to supply an illuminating body of great compactness and at the same time to provide a perfectly sure unfolding of the parachute.

One embodiment of my invention has been shown in the accompanying drawing, wherein:—

Figure 1 is an axial section of the search light projectile; Fig. 2, in larger scale, an axial section of one of the illuminating bodies or "candles" with a folded parachute, and Fig. 3, an axial section of one of the illuminating bodies or "candles" with unfolded parachute in the same scale as Fig. 1.

The search light projectile represented in Fig. 1 is, generally speaking, constructed on the lines of a base chamber shrapnel. A is the shell, B the bursting charge, C the ejecting disk, and D the igniting tube, connecting the time-fuse E with the bursting charge B. In several layers, separated by diaphragms G, the "candles" or illuminating bodies F are distributed around the igniting tube D in the hollow chamber of the shell A. The principal parts of the "candle" are the illuminating material H, a parachute J, made of strong material, suitable to be folded, and inserted between the two, a compression spring or other power source K (Figs. 2 and 3). These several parts of the candle are inclosed in a casing F¹. Said casing is divided into two compartments by a partition f², one of these compartments inclosing the illuminating material H and a match h¹ for igniting the same. The other compartment of the casing F¹ is closed during transportation by a loosely fitting lid F³ making a housing for the compression spring K, as well as for the folded parachute J (Fig. 2), the said spring K resting with one end against the partition f² and with the other against a loose disk N, constituting a support for the parachute J. A chord z¹ connects the parachute J with

the casing F¹ in the manner indicated in Figs. 2 and 3, by means of a collar p¹ on the bolt P engaging with the opposite side of the partition f².

As shown in Fig. 1, the candles F are arranged in the projectile in such a manner, that the lids F³ are placed toward the base of the projectile. The height of the layers in which the candles are stacked in the projectile, is identical with the height of one "candle" including its lid, so that the lids F³ although subjected to the pressure of the springs K, will easily be kept in position by the rear walls in the hollow cells provided for the candles in the projectile.

In operation the time-fuse of the now described search light projectile, is set to ignite the bursting charge when the projectile is on the descending part of the trajectory. When the bursting charge B has been ignited, the flame sets fire to the match h¹ and subsequently to each separate candle. As soon as the candle is set free, the spring K throws off the lid F³ from the casing F¹ and ejects the parachute. Directly the parachute is outside the casing, the resistance of the air, acting thereon, unfolds it. Owing to the fact that the compartment of the casing F, inclosing the parachute, and capped by the lid, is turned toward the base of the projectile while inclosed therein, and that the ejection of the "candle" takes place on the descending part of the trajectory, when the rear end lies higher than the front end of the candle, the unfolding of the parachute is greatly facilitated. After their ejection, the candles fall slowly to the ground while the lighting material is burning.

Having thus described my invention, what I claim as new therein and desire to secure by Letters Patent, is:—

1. A search light projectile comprising a plurality of illuminating bodies and means for sustaining said bodies in the air after liberation; said means comprising a parachute, folded and housed in a compartment of the illuminating bodies, while said bodies are deposited in the projectile chamber.

2. A search light projectile comprising a plurality of illuminating bodies and means for sustaining said bodies in the air after liberation; said means comprising a parachute, folded and housed in a compartment of the illuminating bodies, while said bod-

ies are deposited in the projectile chamber, and said illuminating bodies containing a power source acting on said parachute for ejection.

3. A search light projectile comprising a plurality of illuminating bodies and means for sustaining said bodies in the air after liberation; said means comprising a parachute, folded and housed in a compartment of the illuminating bodies, said bodies constructed to fill entirely the cells intended for them in the projectile, and deposited therein with the end containing the parachute turned toward the base of the projectile.

4. A search light projectile comprising a shell body, a time-fuse, and a bursting charge, in combination with a plurality of illuminating bodies shaped to conform with

the shape of the cells of said shell body, parachutes for said bodies, folded and contained in a compartment of the illuminating bodies; while housed in the projectile; a power source also contained in said bodies and made to act on the parachute when the illuminating body has been liberated from the projectile on exploding the time-fuse, said parachutes sustaining the several illuminating bodies in the air while the illuminating material is burning.

The foregoing specification signed at Barmen, Germany, this 21st day of April, 1911.

ADOLF WÜNSCHE. [L. s.]

In presence of—
CHAS. J. WRIGHT,
ALFRED HENKEL.