



(19) **United States**
(12) **Patent Application Publication**
Shen et al.

(10) **Pub. No.: US 2009/0070679 A1**
(43) **Pub. Date: Mar. 12, 2009**

(54) **METHOD AND SYSTEM FOR SOCIAL NETWORK ANALYSIS**

Related U.S. Application Data

(75) Inventors: **Zeqian Shen**, Alameda, CA (US);
Neelakantan Sundaresan,
Mountain View, CA (US)

(60) Provisional application No. 60/971,904, filed on Sep. 12, 2007, provisional application No. 60/984,677, filed on Nov. 1, 2007.

Publication Classification

Correspondence Address:
SCHWEGMAN, LUNDBERG & WOESSNER,
P.A.
P.O. BOX 2938
MINNEAPOLIS, MN 55402 (US)

(51) **Int. Cl.**
G06F 3/00 (2006.01)
(52) **U.S. Cl.** **715/733**
(57) **ABSTRACT**

Methods and system for social network analysis are described. In one embodiment, user interaction data of a time period for a plurality of users in a social network may be accessed. Network analysis may be performed on the user interaction data. A necktie-shaped graph may be generated from the user interaction data in accordance with the performing of the network analysis. The necktie-shaped graph may be utilized for analysis of the social network.

(73) Assignee: **eBay Inc.**, San Jose, CA (US)

(21) Appl. No.: **11/967,221**

(22) Filed: **Dec. 30, 2007**

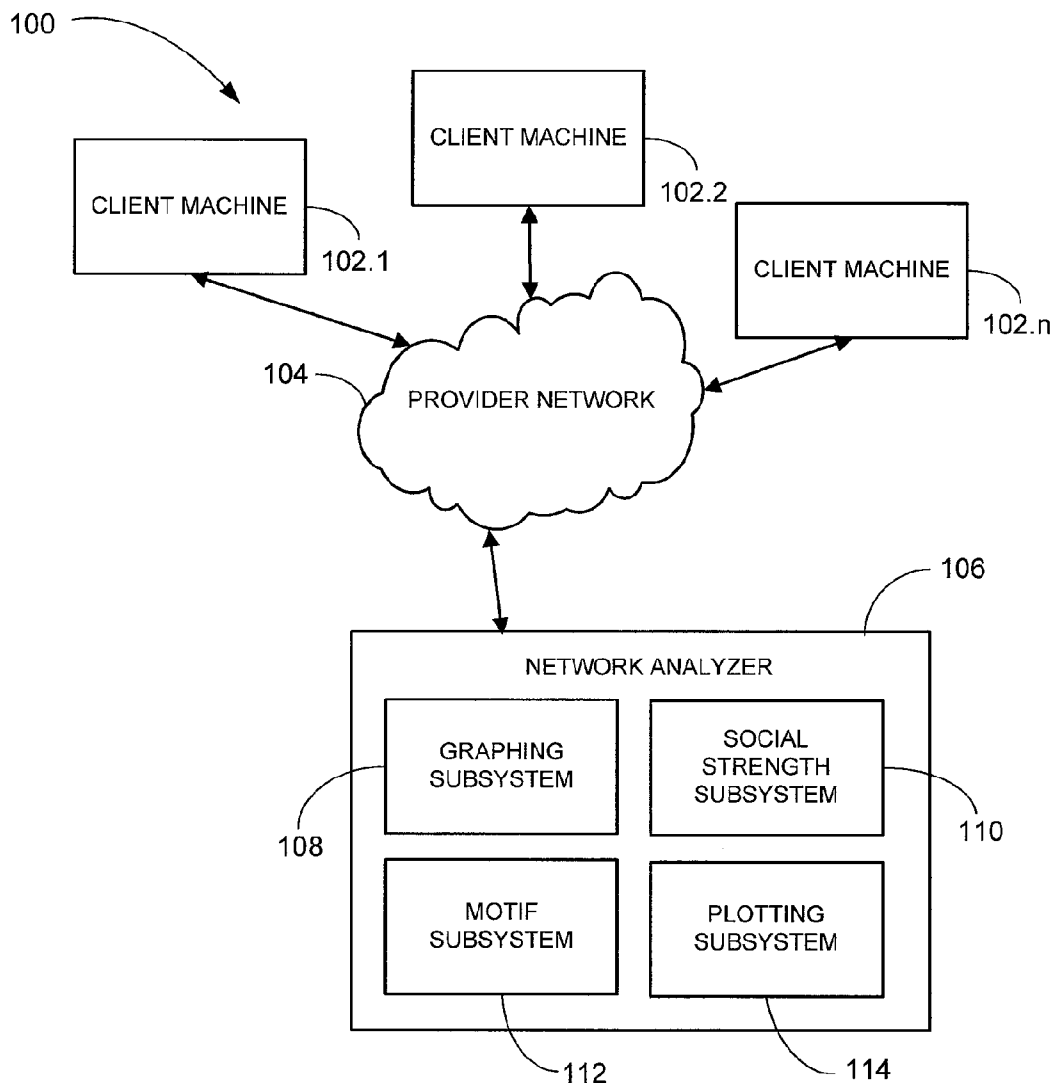

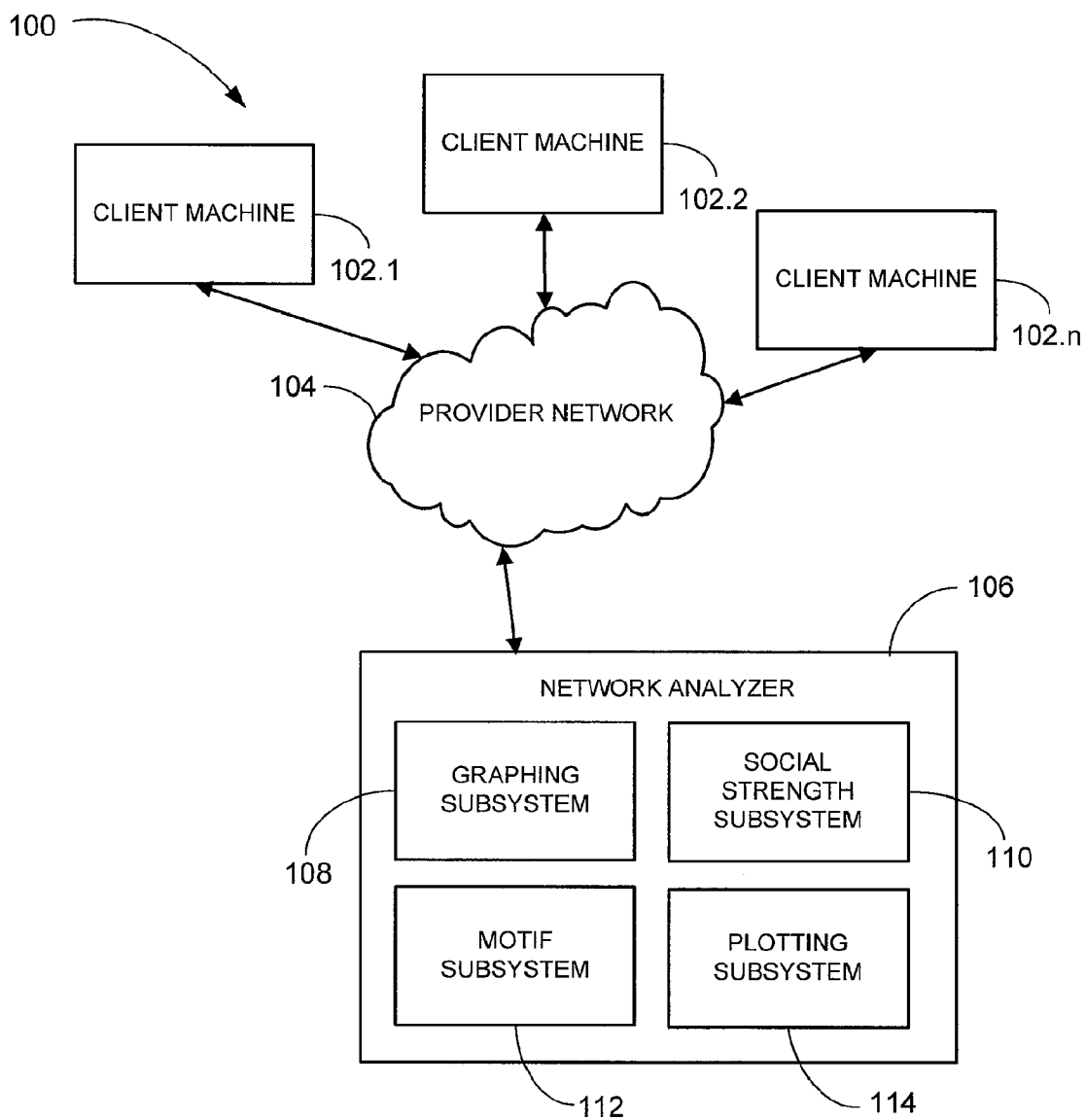

FIGURE 1

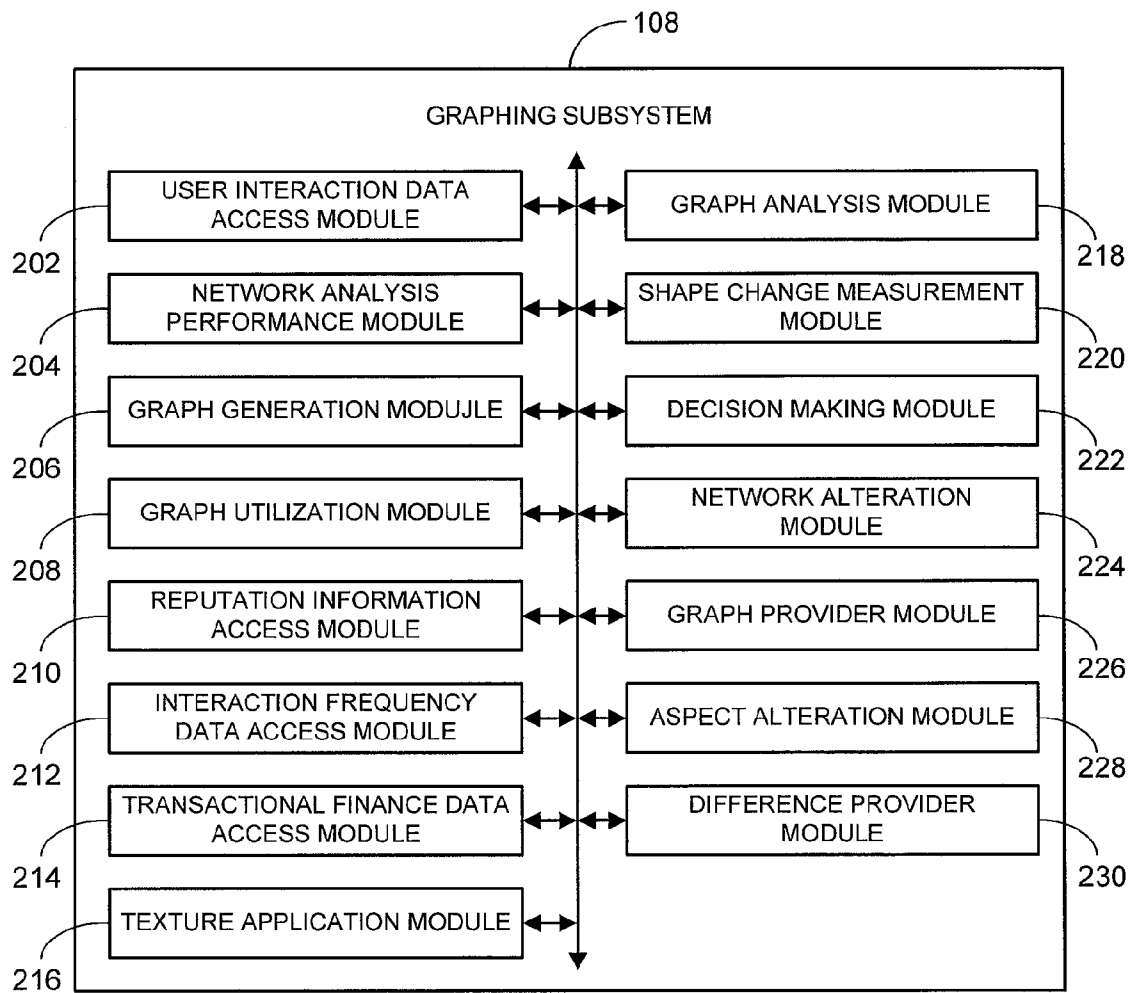

FIGURE 2

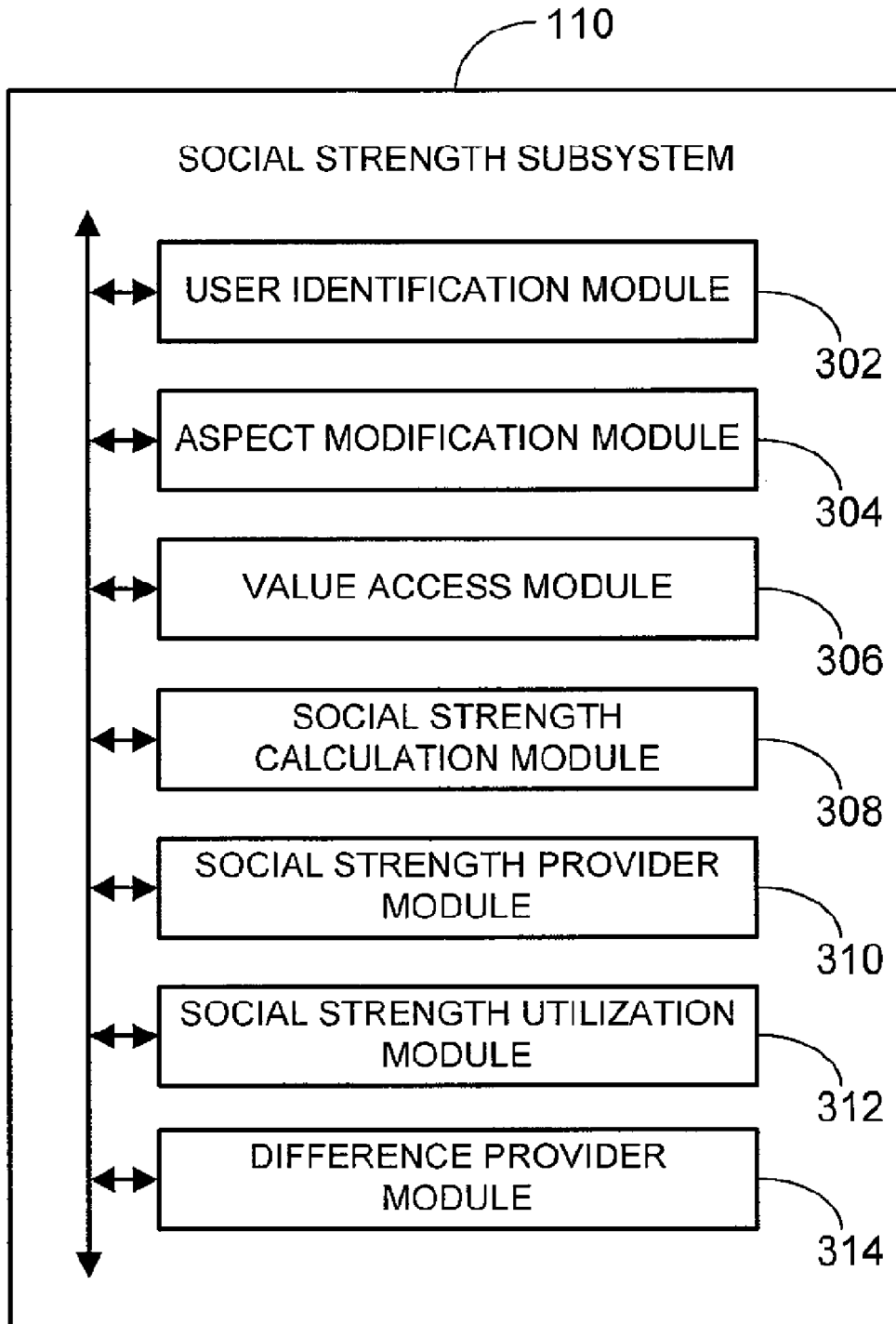

FIGURE 3

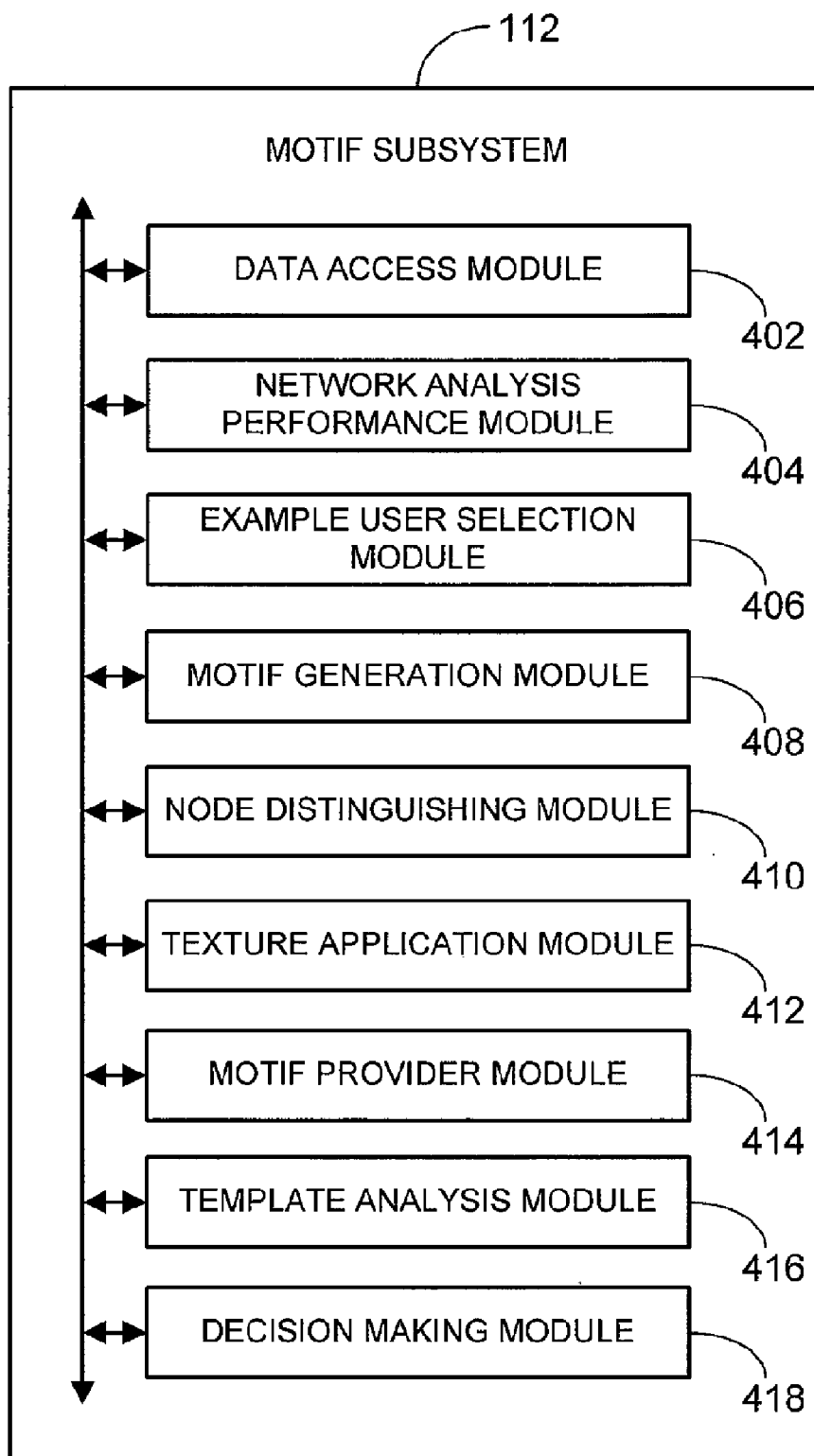

FIGURE 4

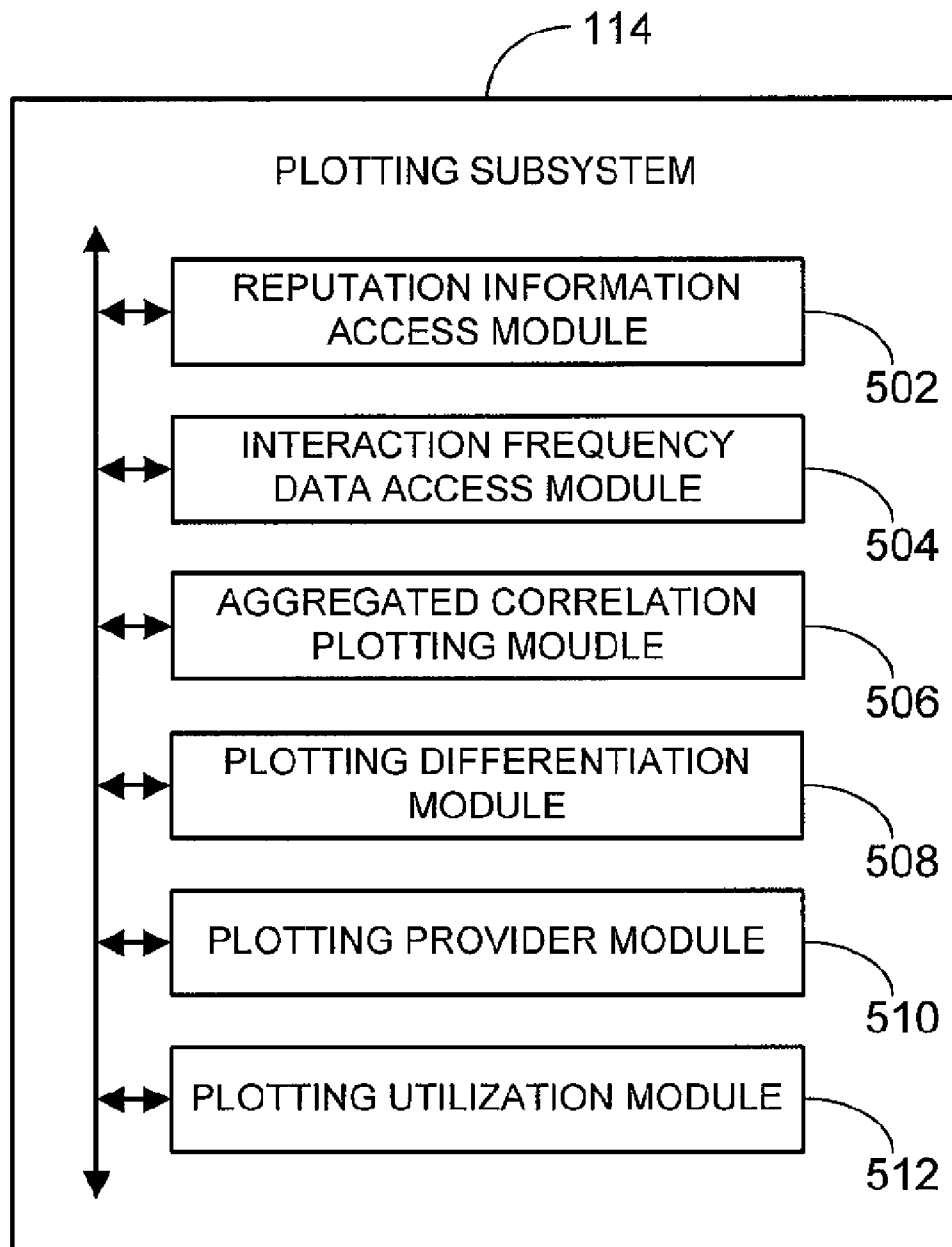

FIGURE 5

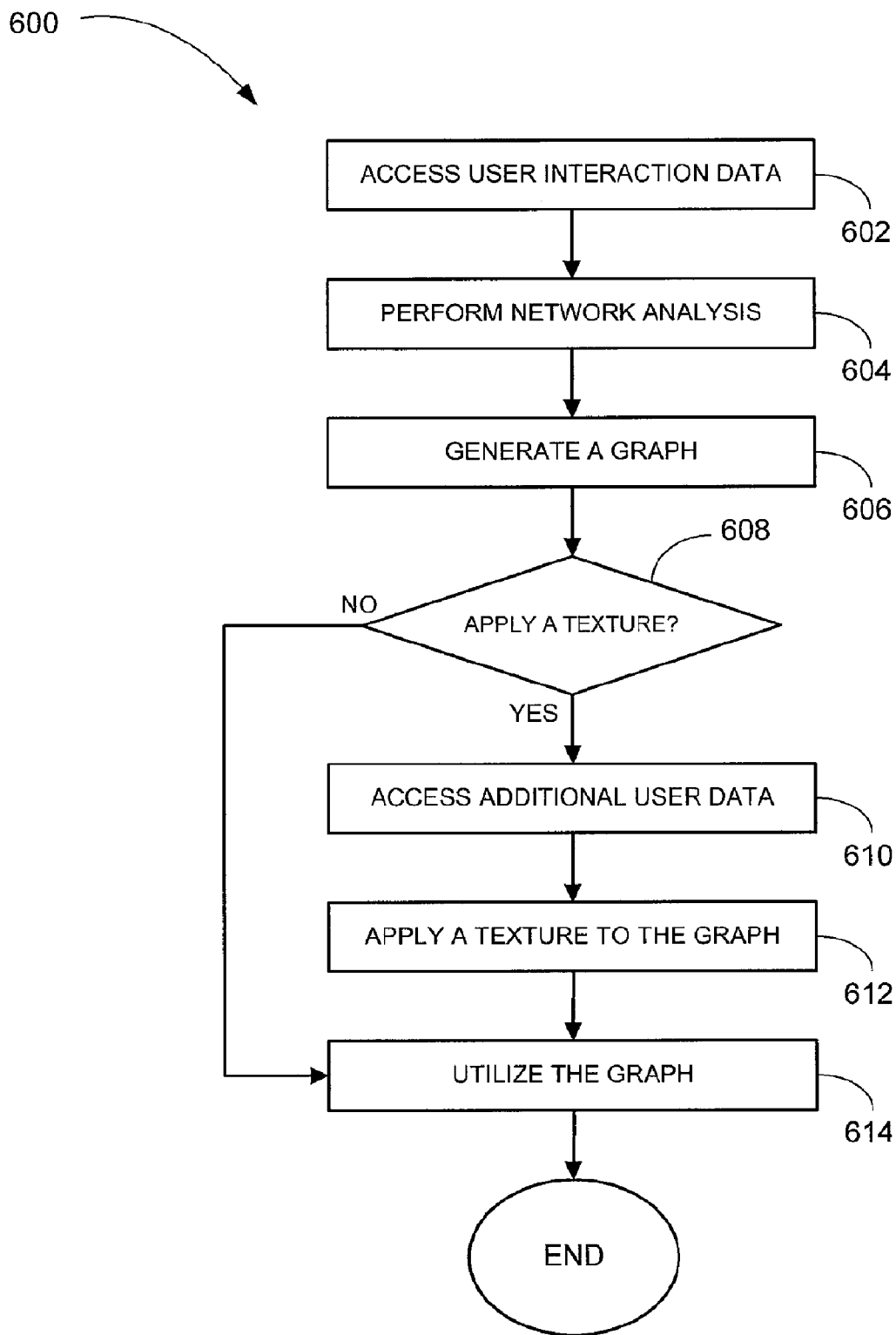

FIGURE 6

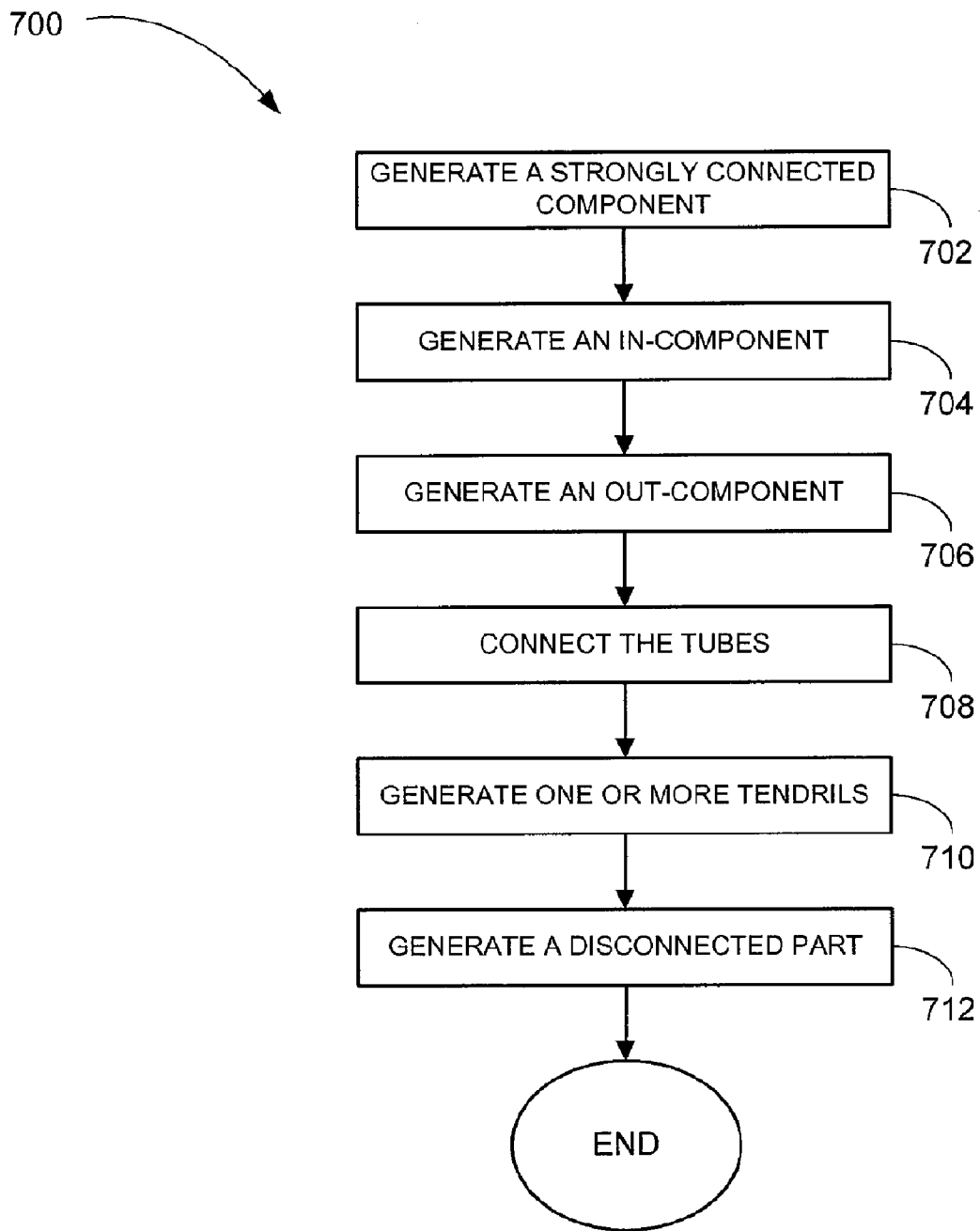

FIGURE 7

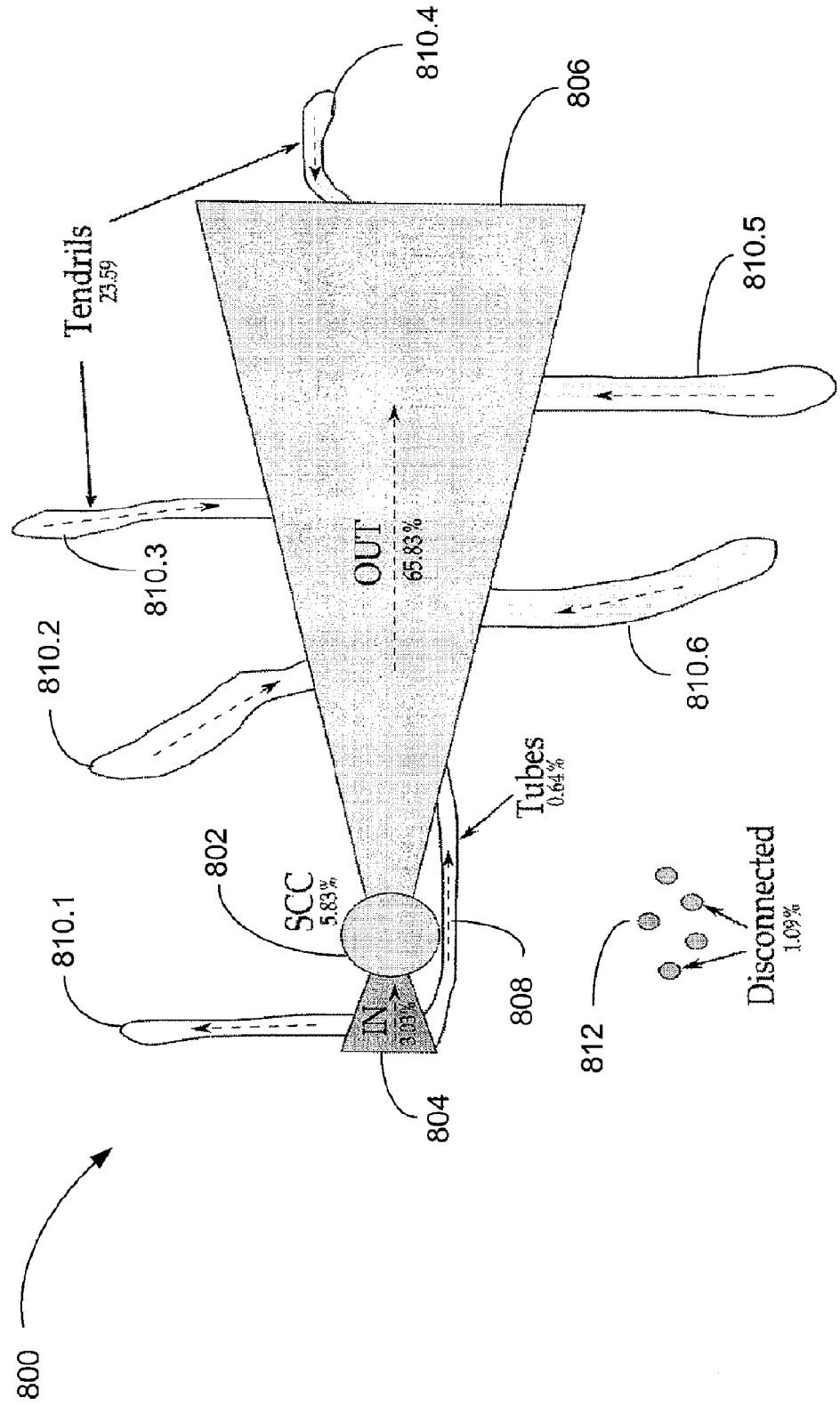

FIGURE 8A

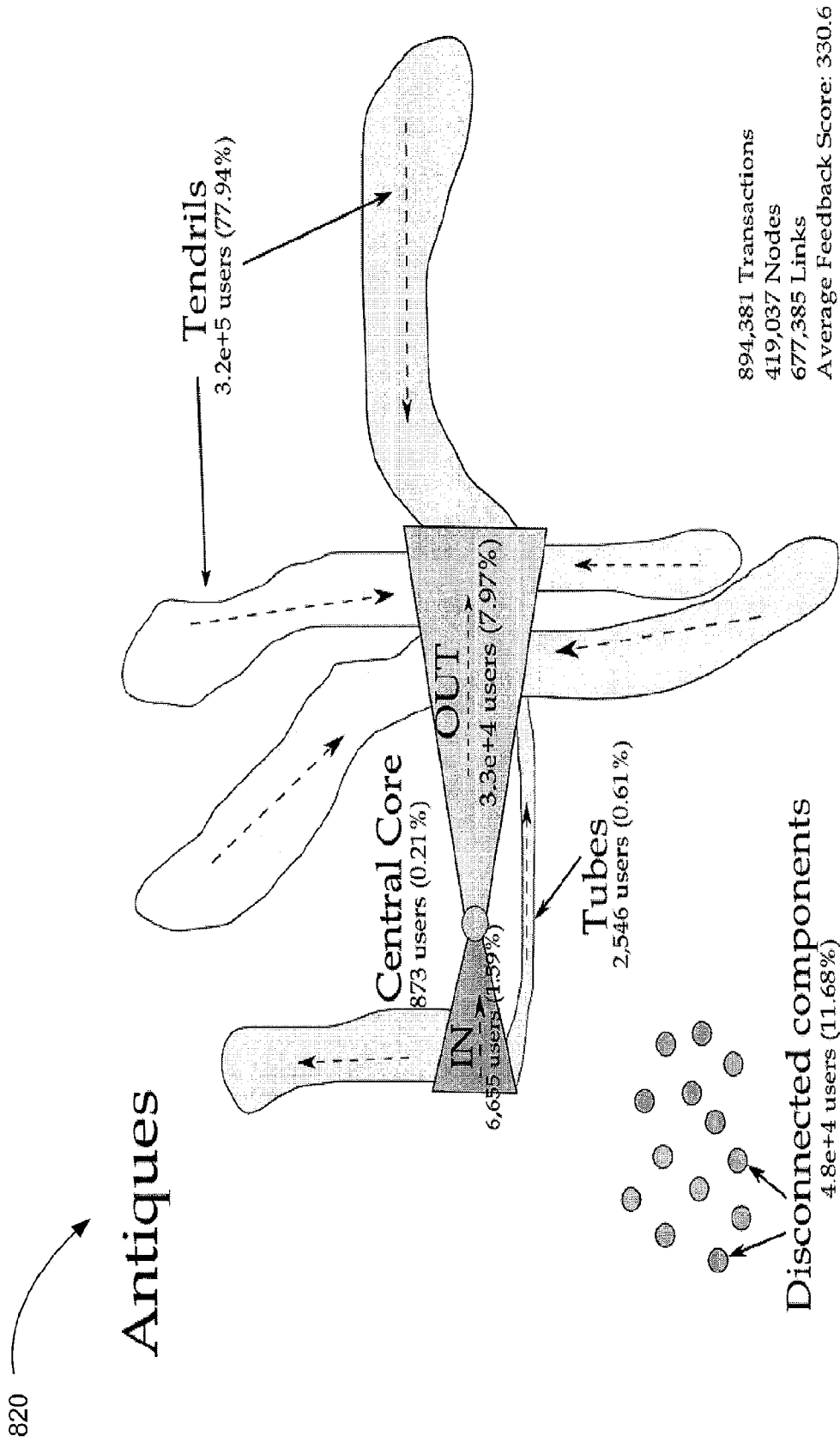

FIGURE 8B

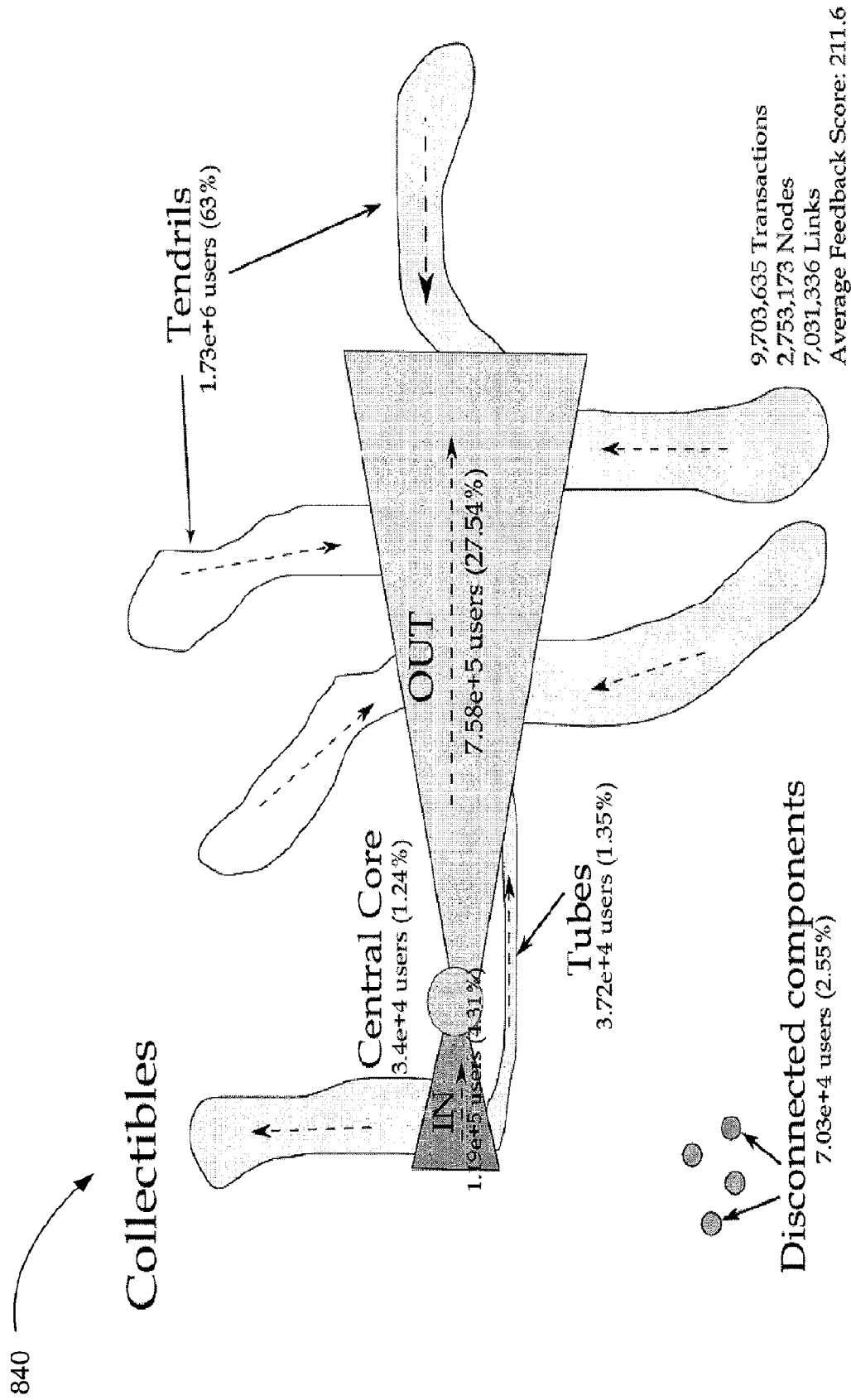

FIGURE 8C

860
Sports Mem, Cards & Fan Shop

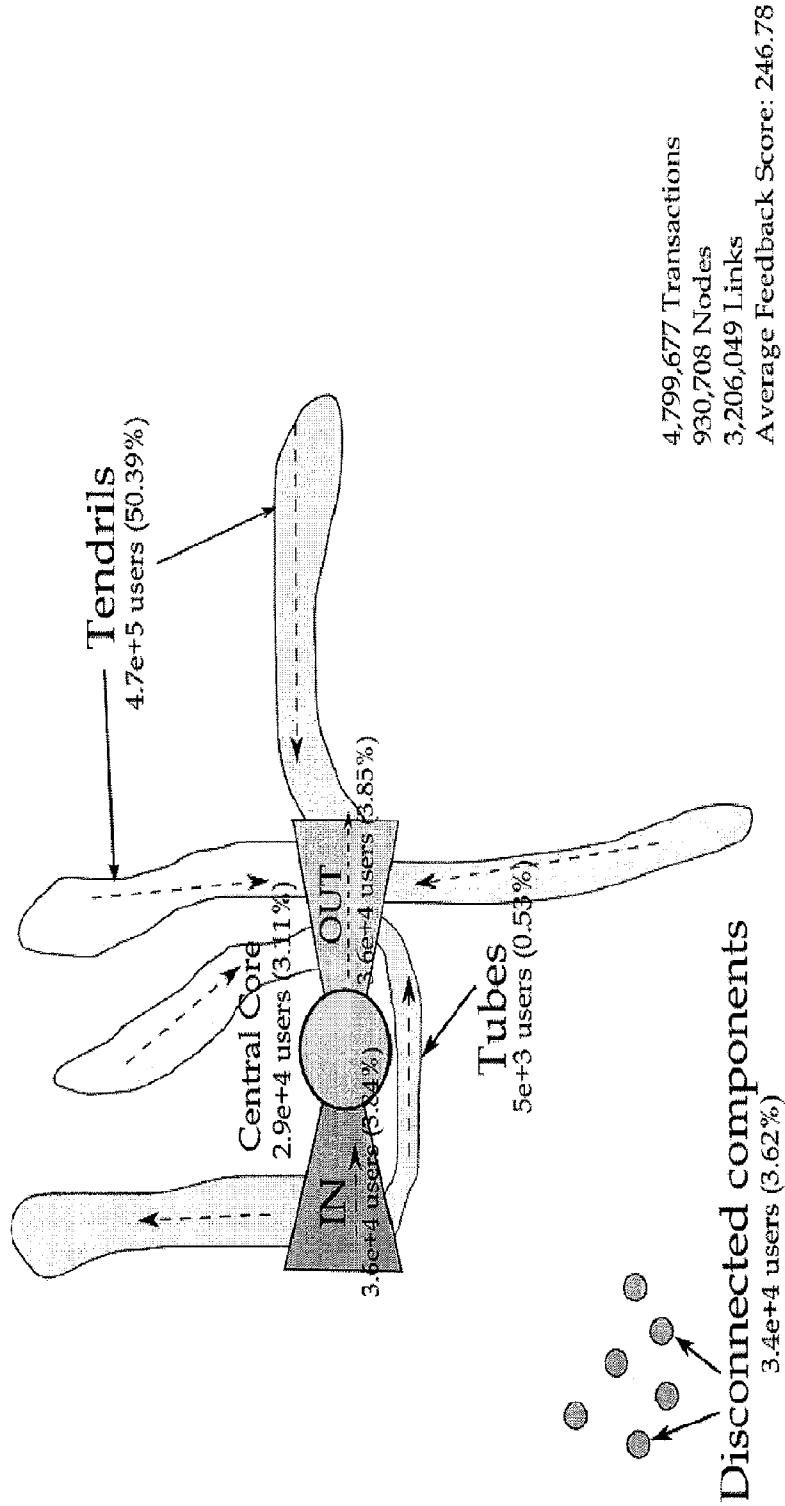

FIGURE 8D

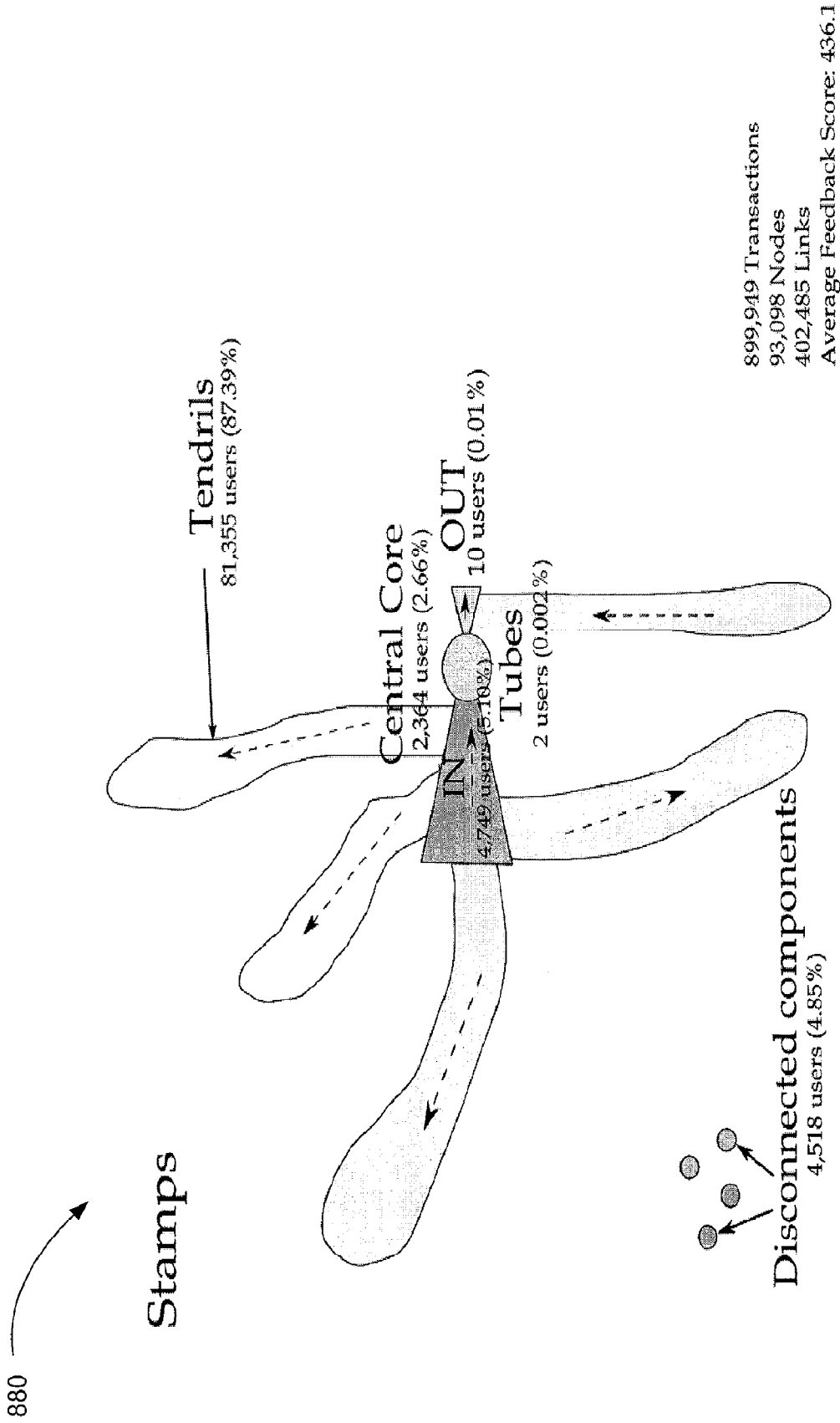

FIGURE 8E

900

	910	912	914	916	918	920
	SCC	IN	OUT	Tndrls	Tube	Disc
902	5.8	3.03	65.8	23.6	0.6	1.09
Av. fdbck	475.7	456.4	66.8	43.6	112.3	56.28
Prch	15.2	0.23	78.4	5.9	0.2	0.11
Av	14.2	0.42	6.5	1.4	1.8	0.56
Sale	59.8	35.5	2.5	1.7	0.4	0.11
Av	55.8	63.8	0.2	0.4	3.2	0.56

908

FIGURE 9

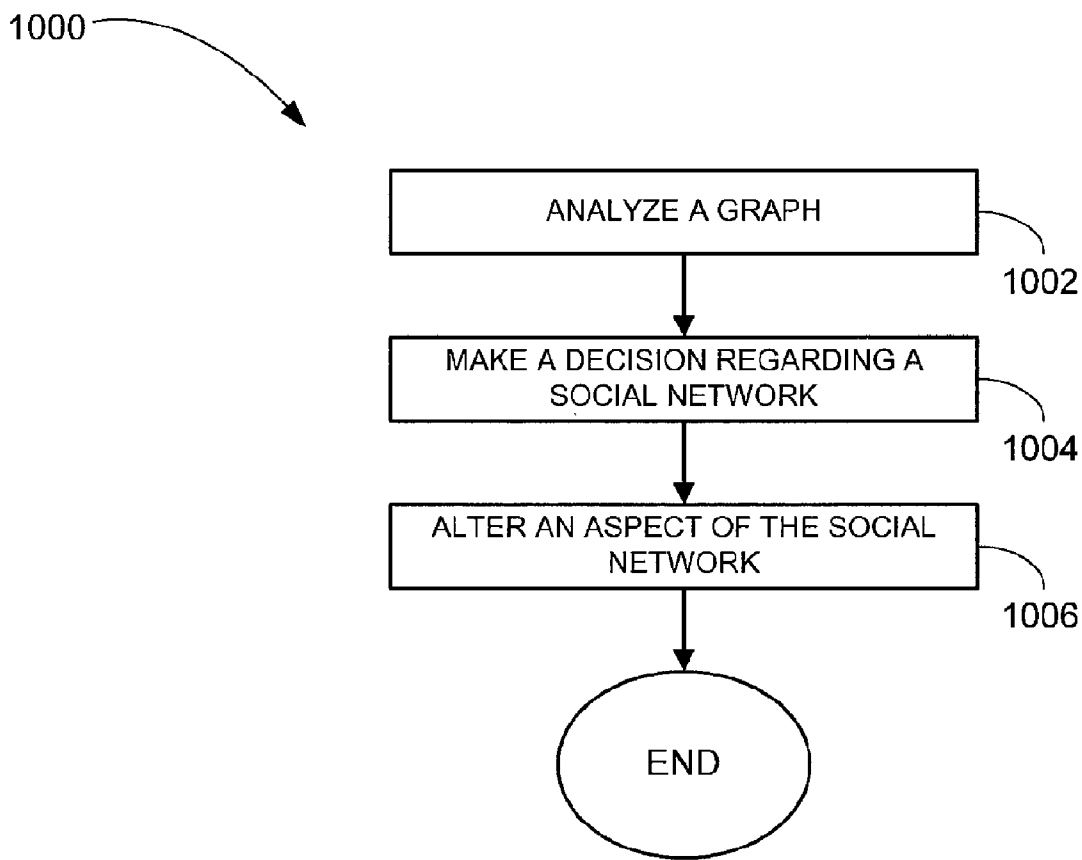

FIGURE 10

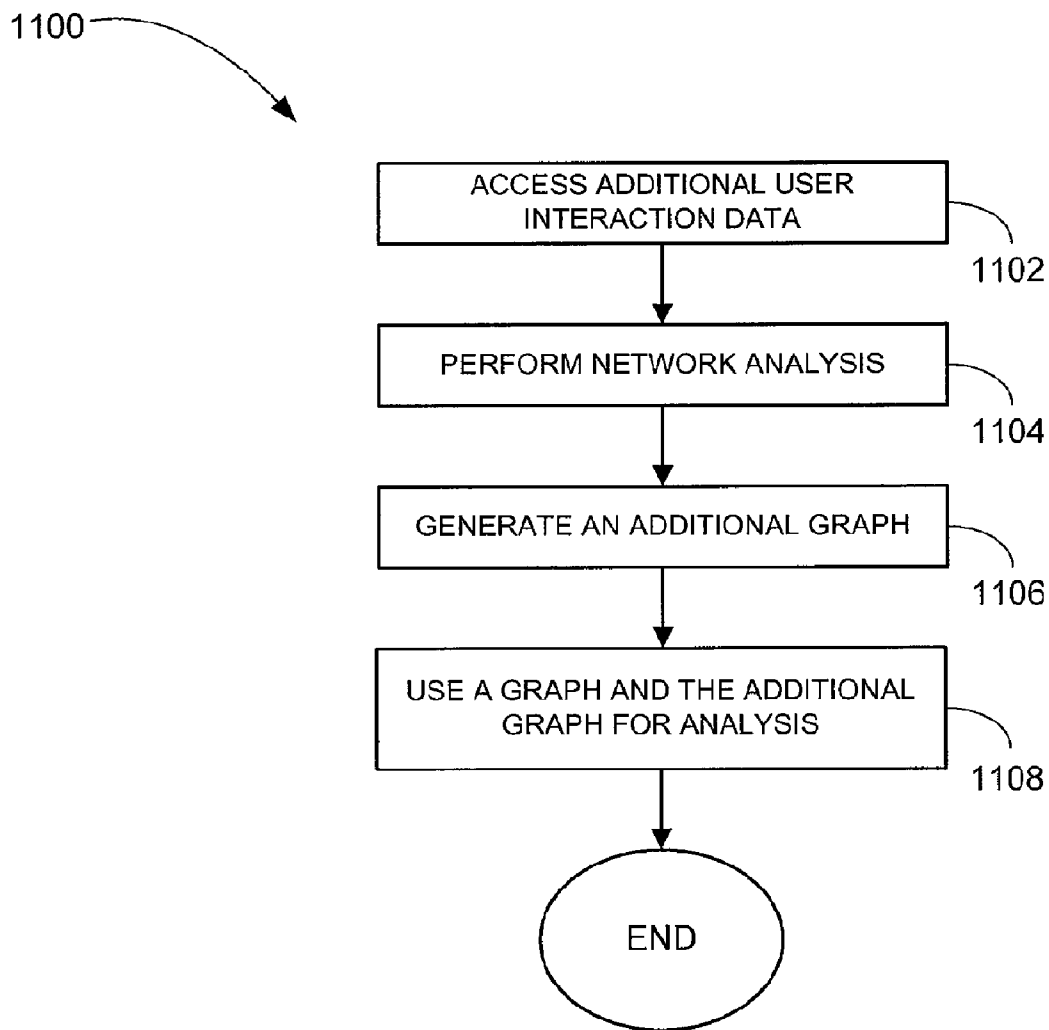

FIGURE 11

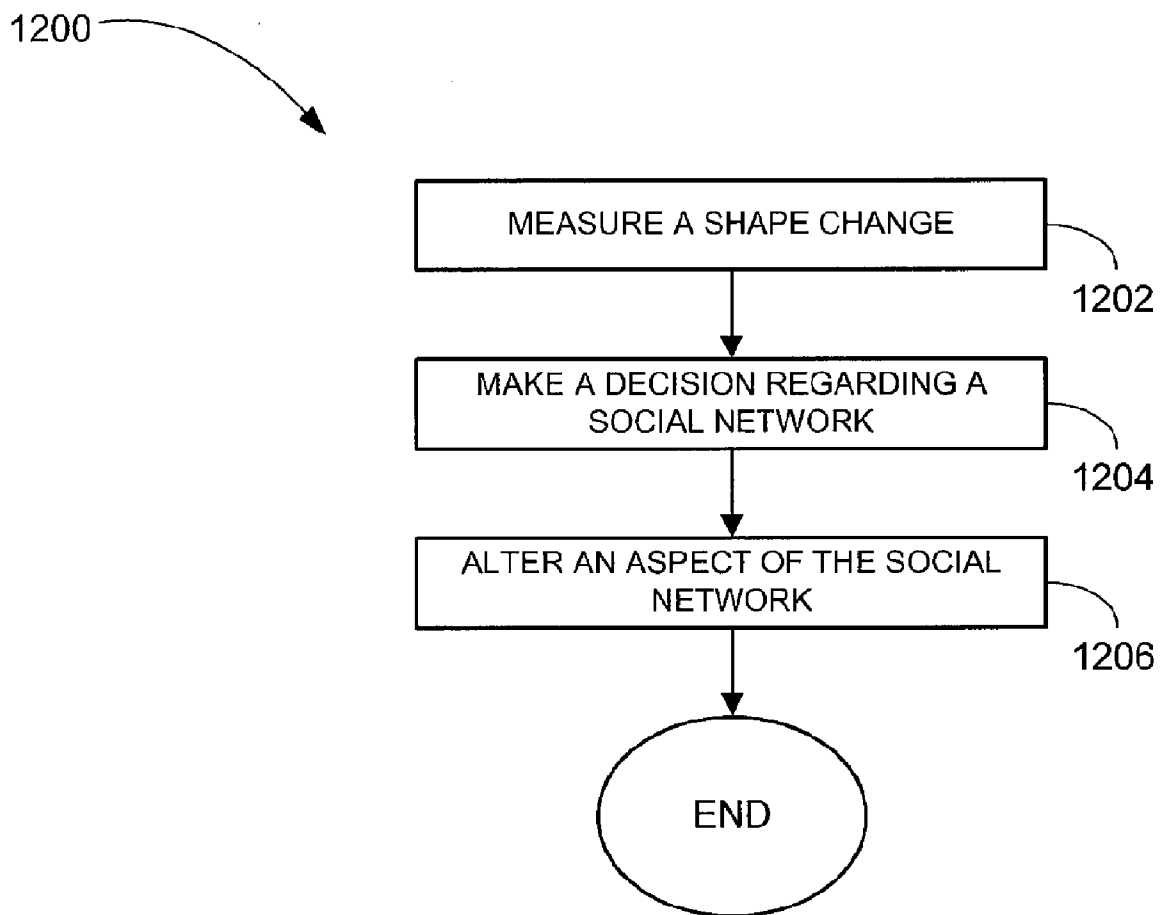

FIGURE 12

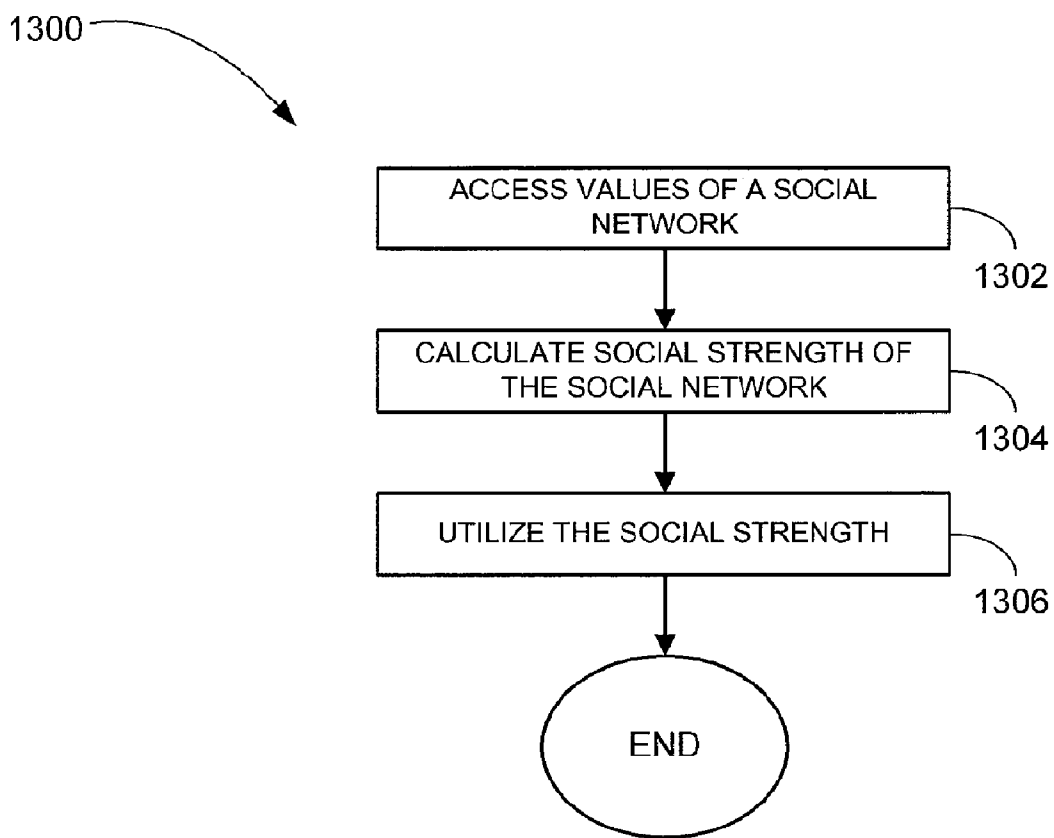

FIGURE 13

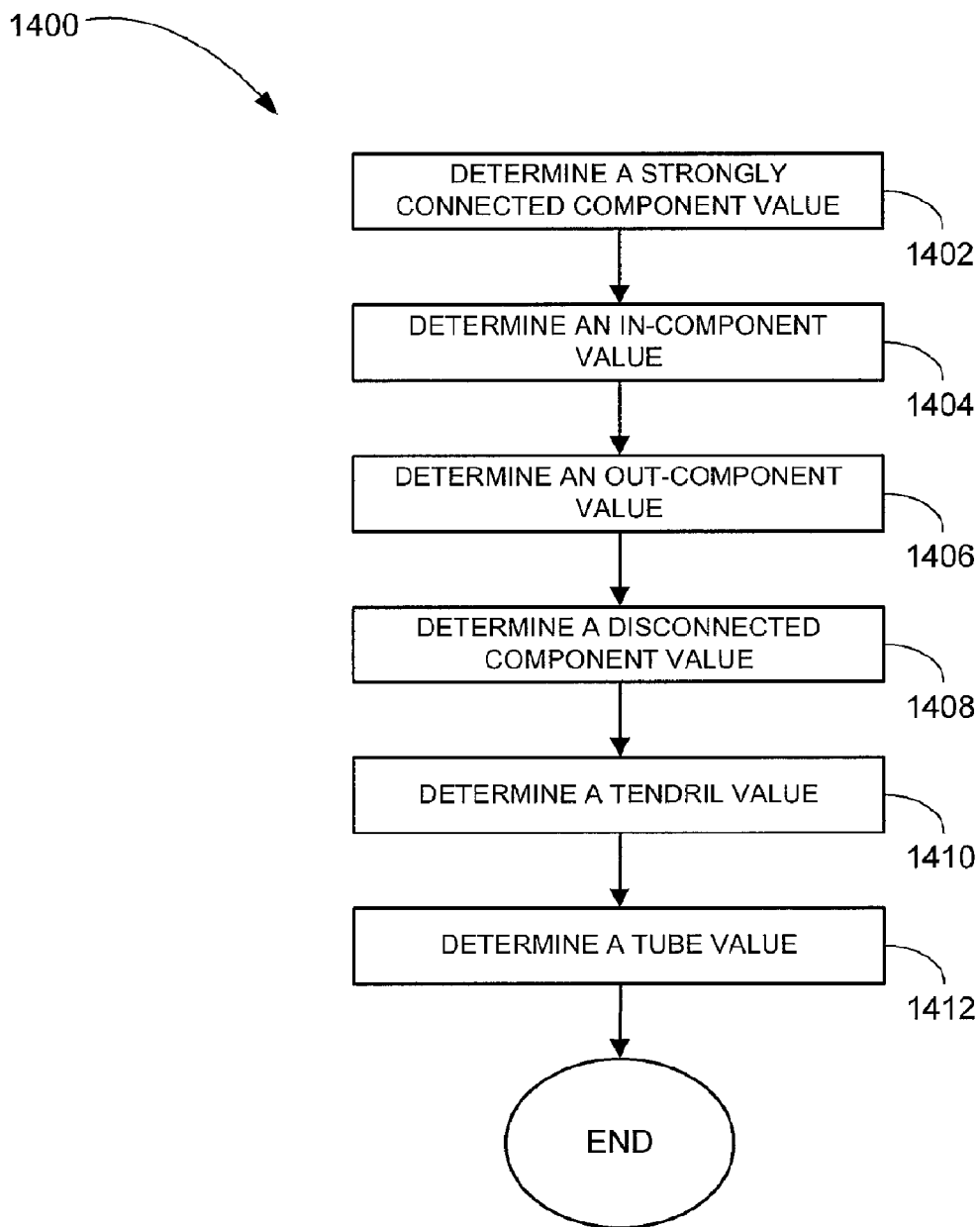

FIGURE 14

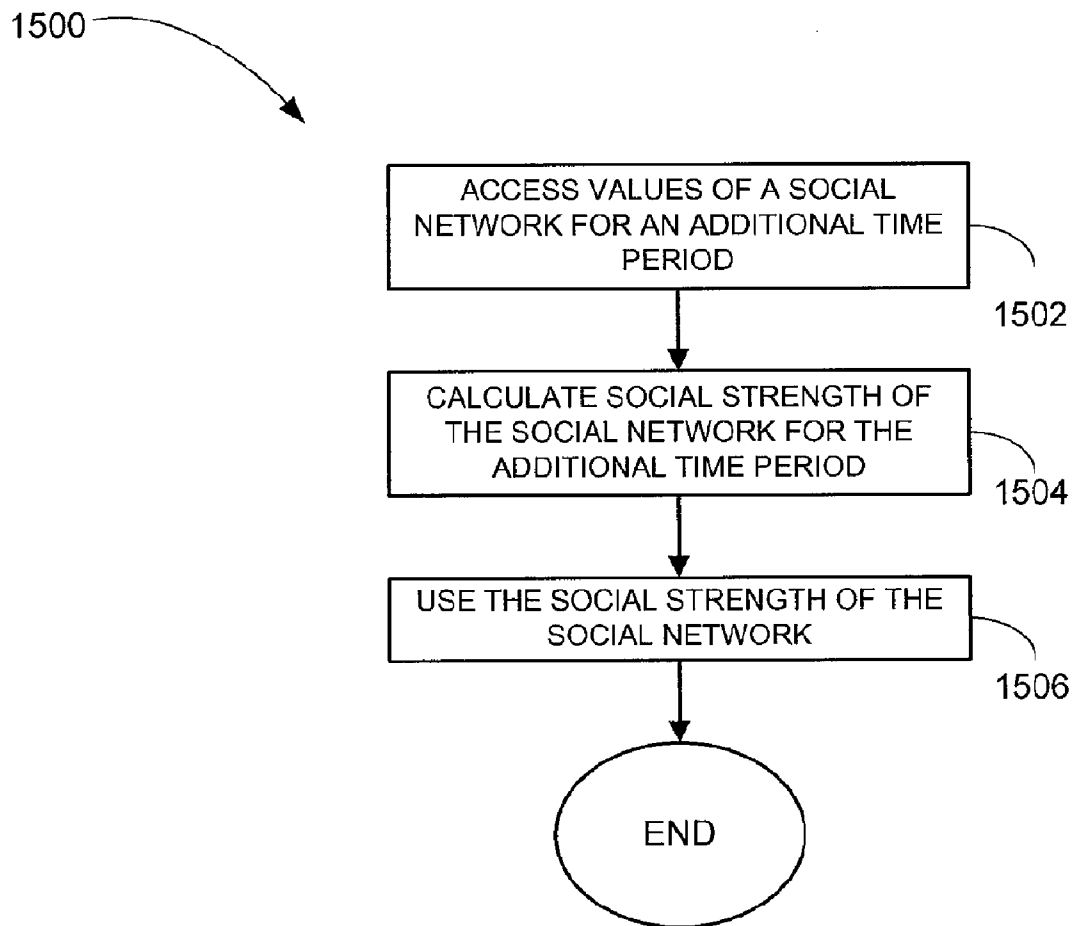

FIGURE 15

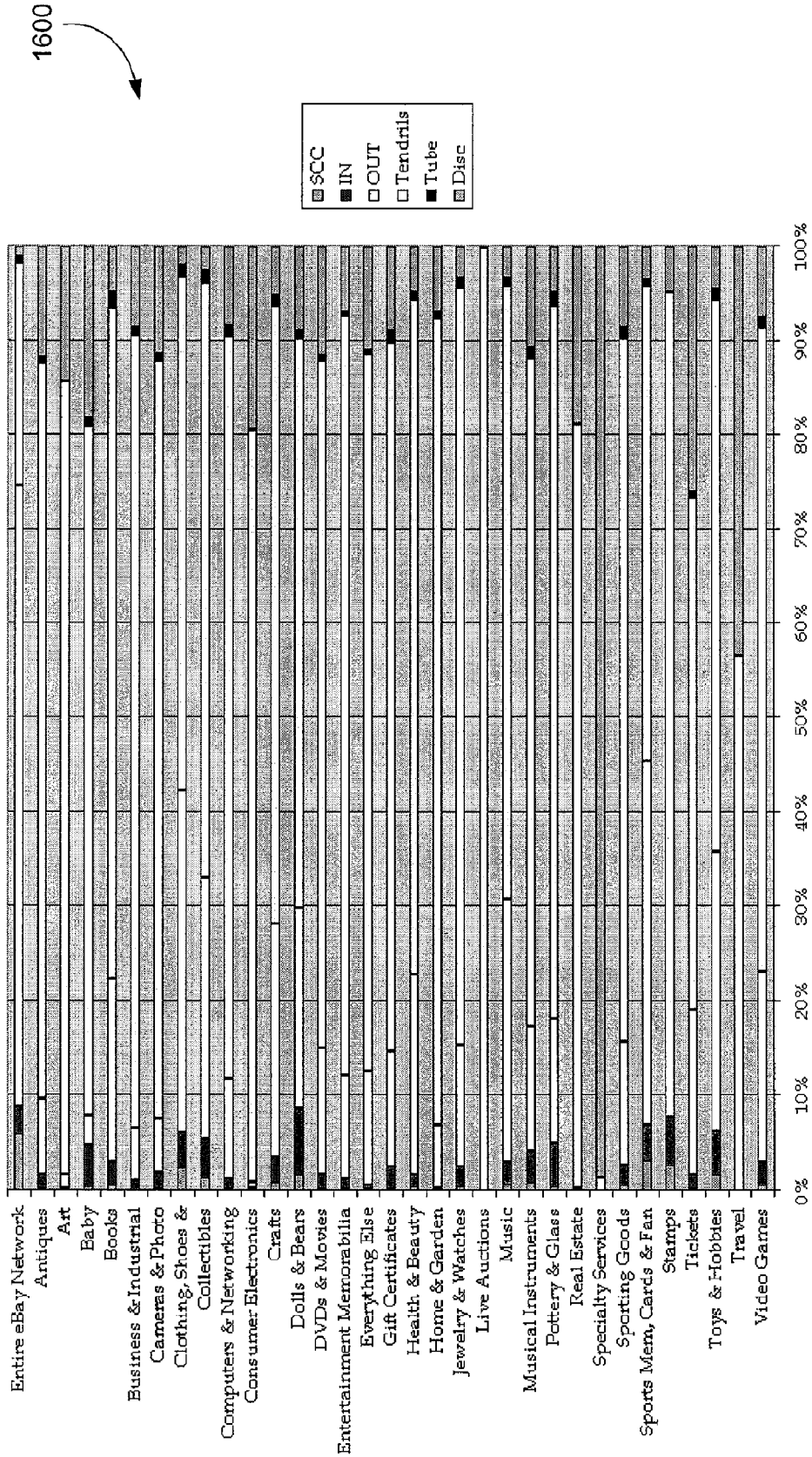

FIGURE 16

1700

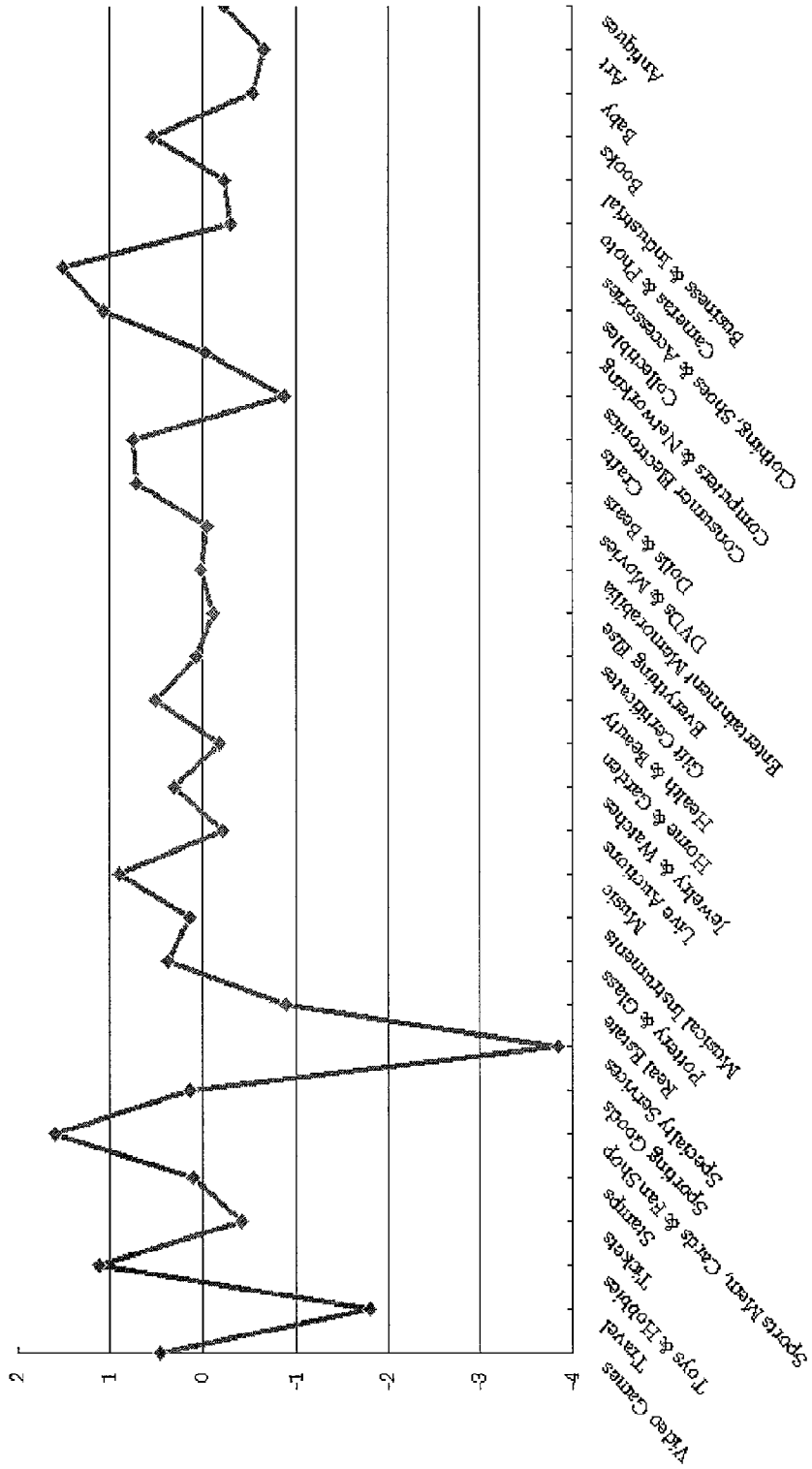

FIGURE 17

1800

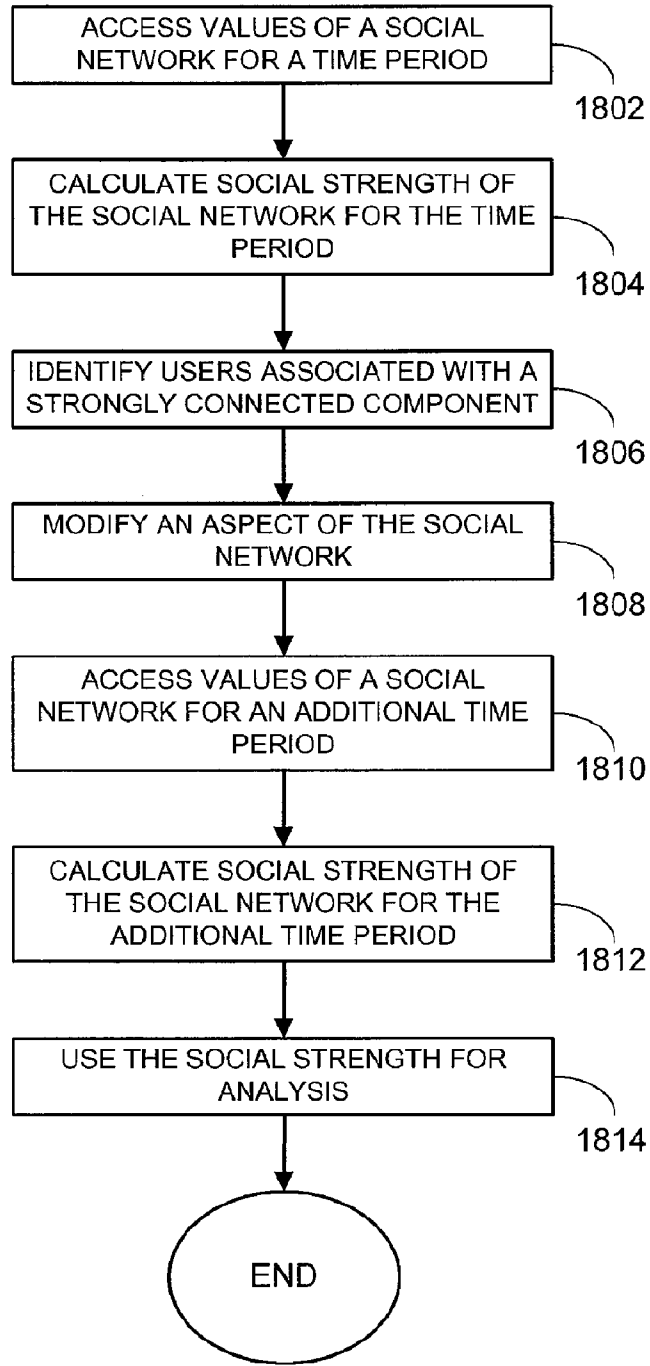

FIGURE 18

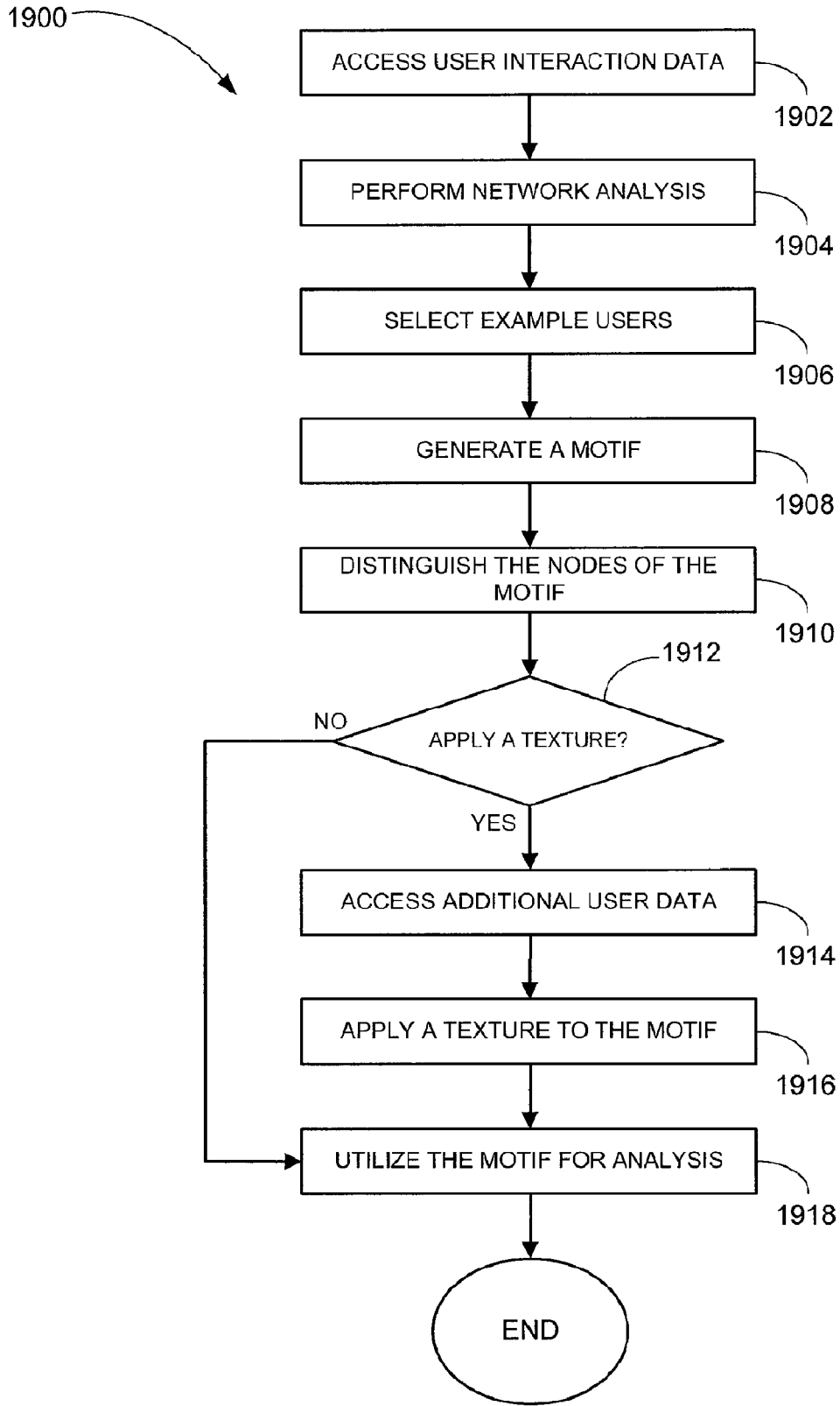

FIGURE 19

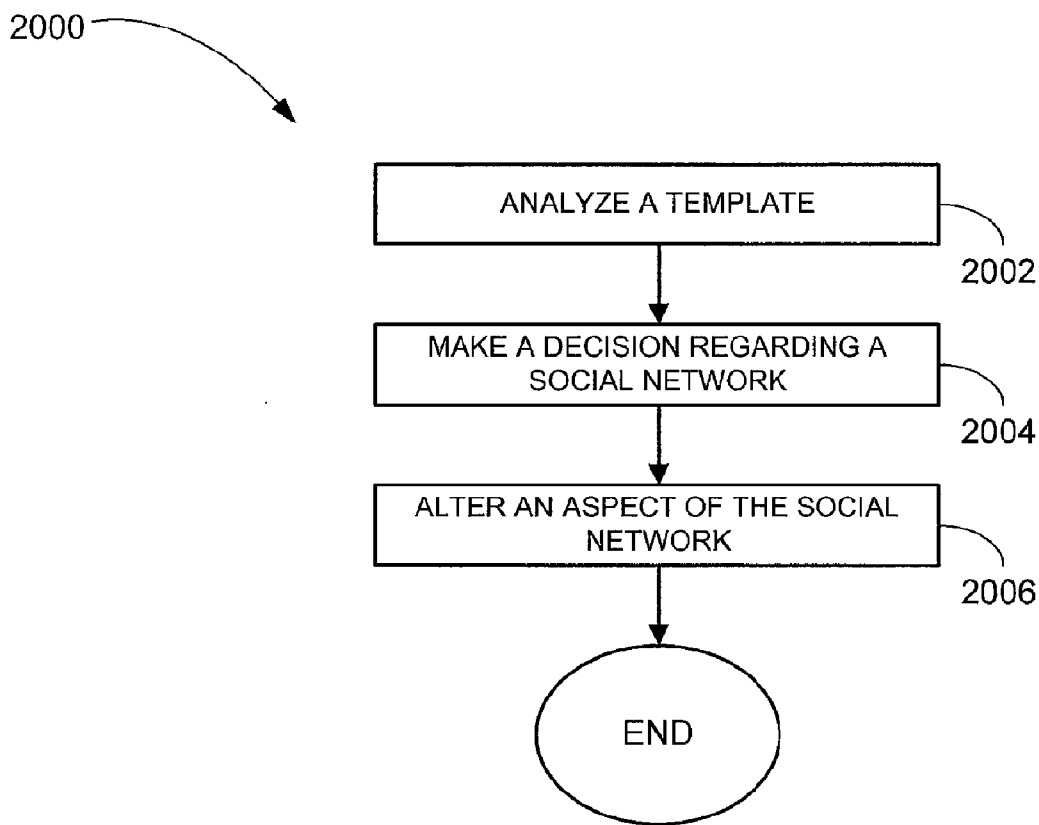

FIGURE 20

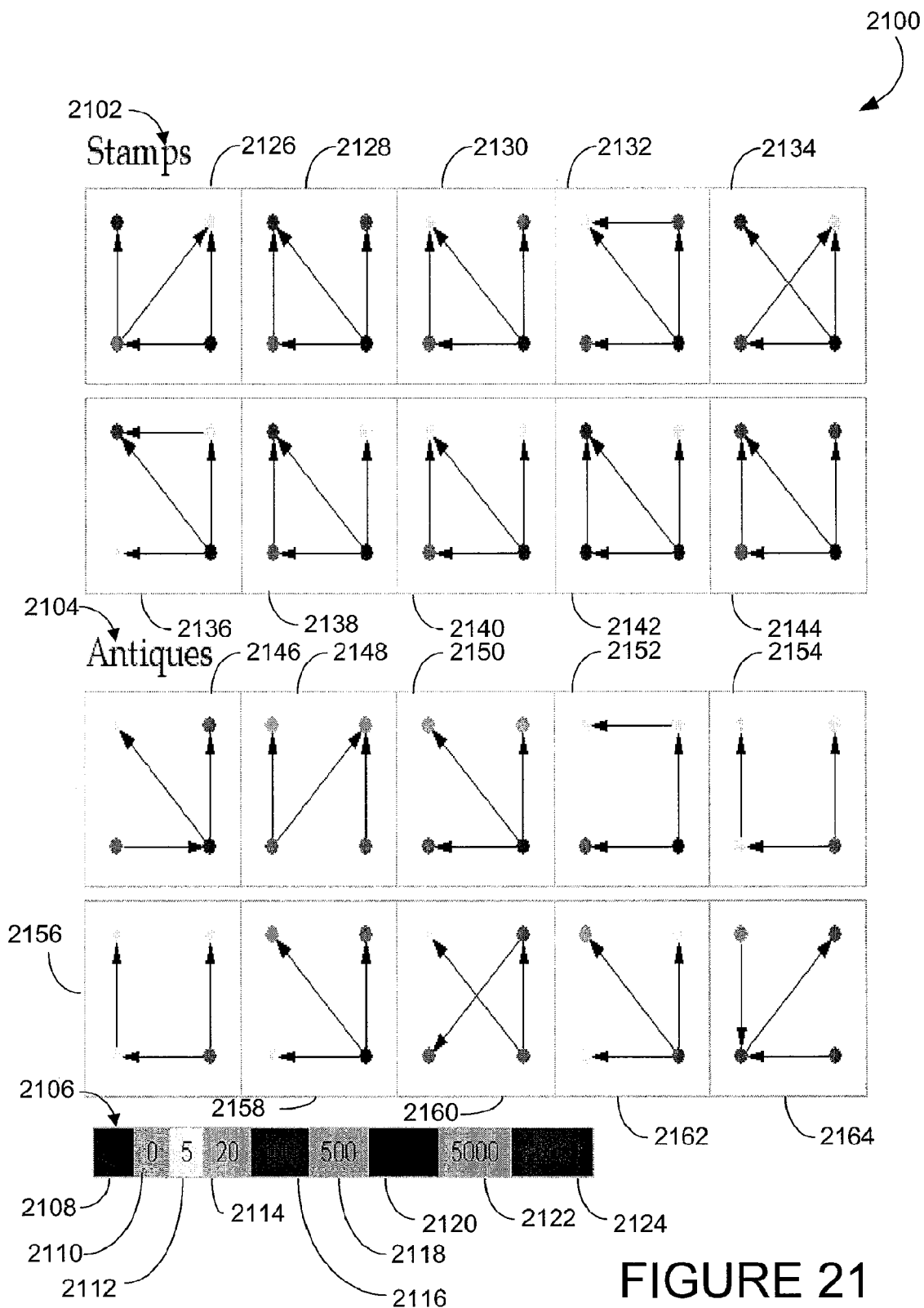

FIGURE 21

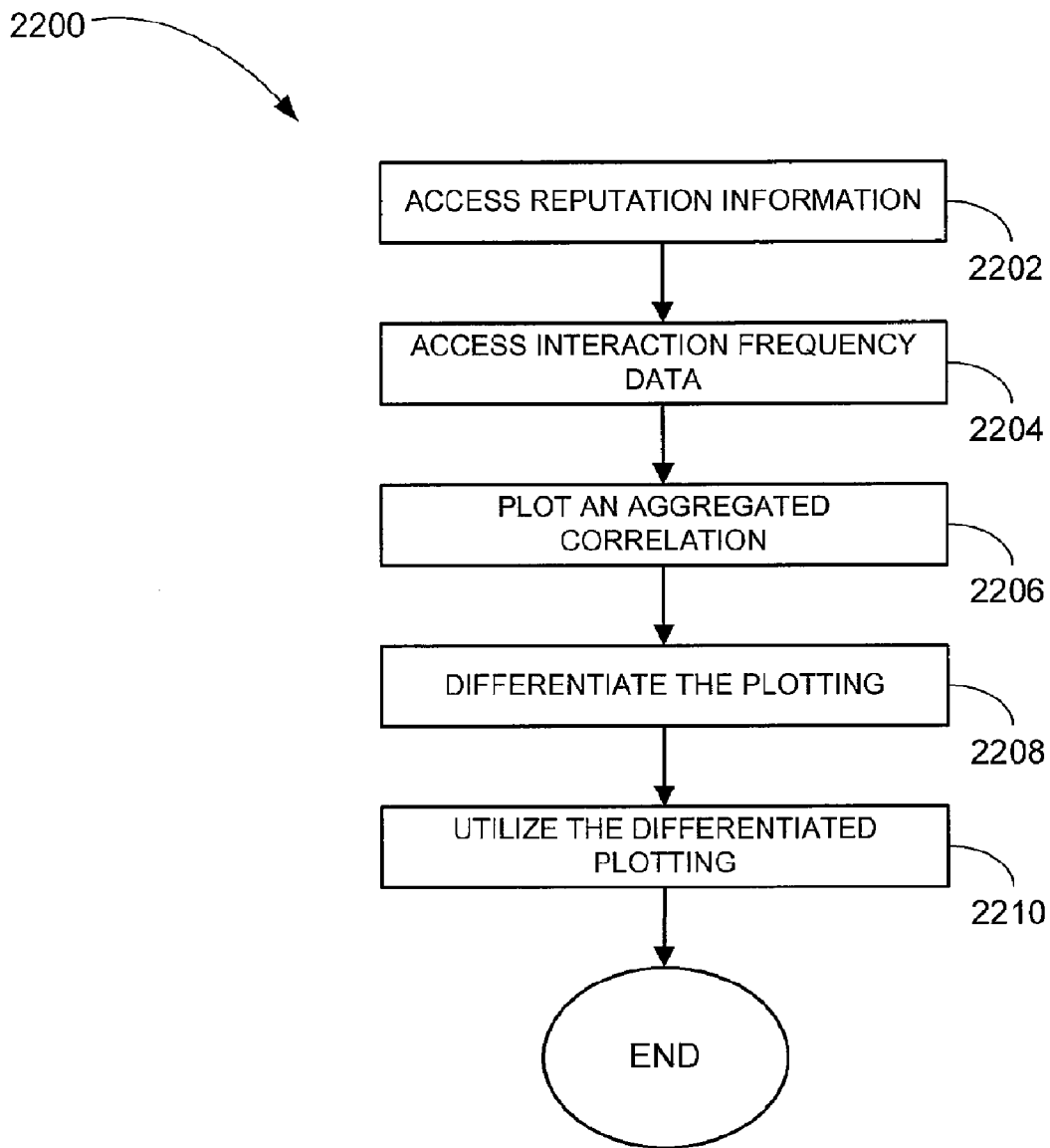

FIGURE 22

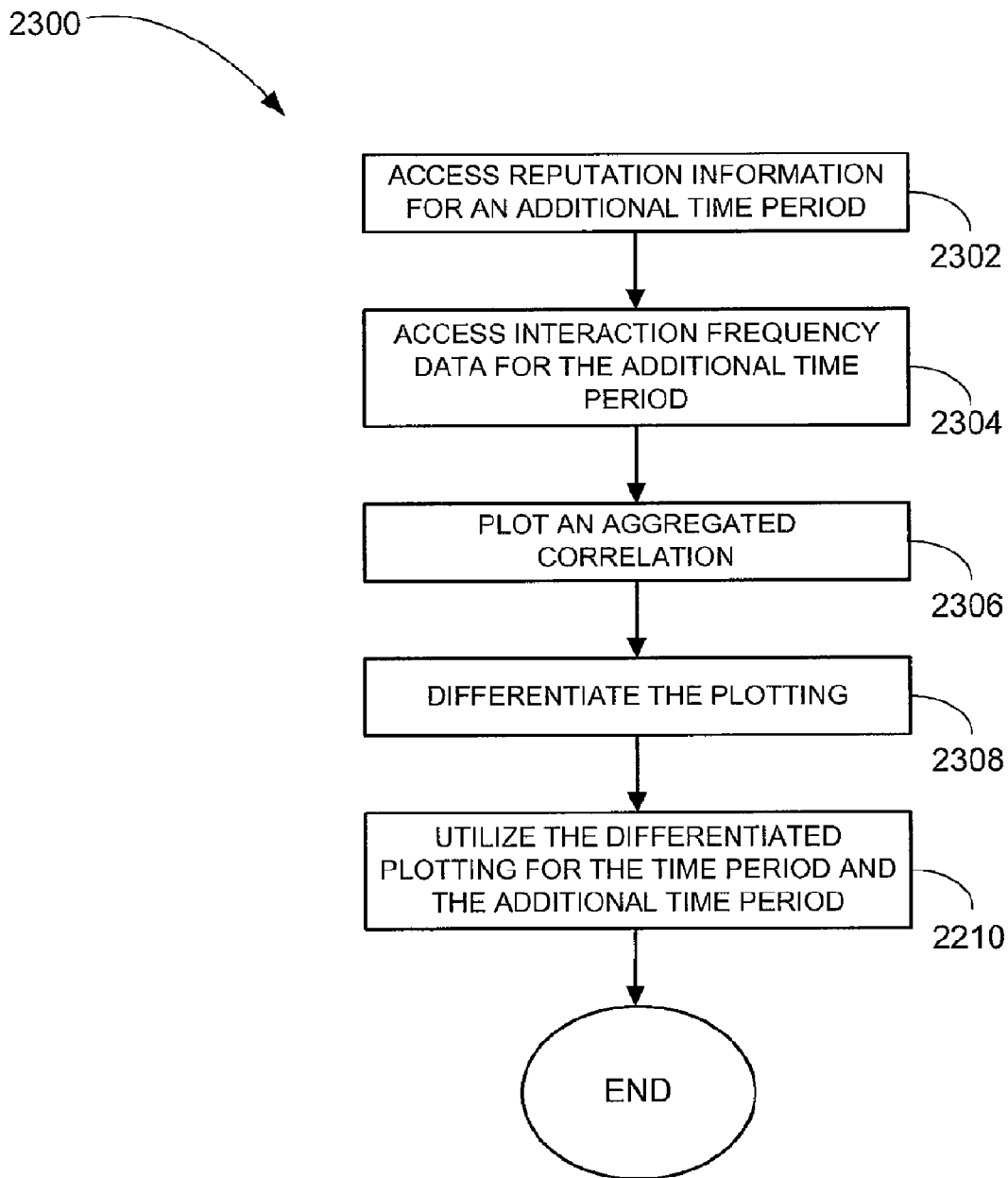

FIGURE 23

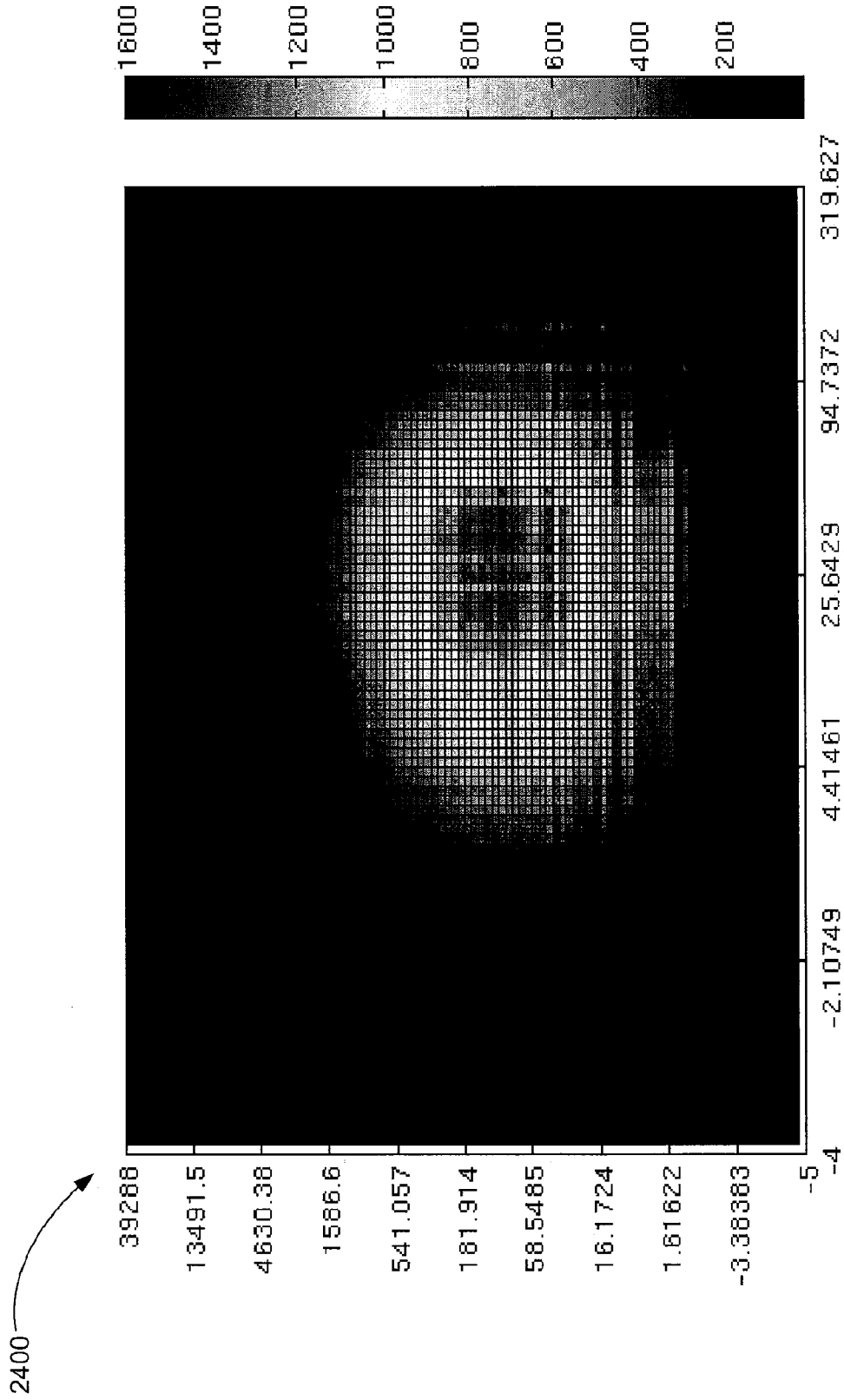

FIGURE 24

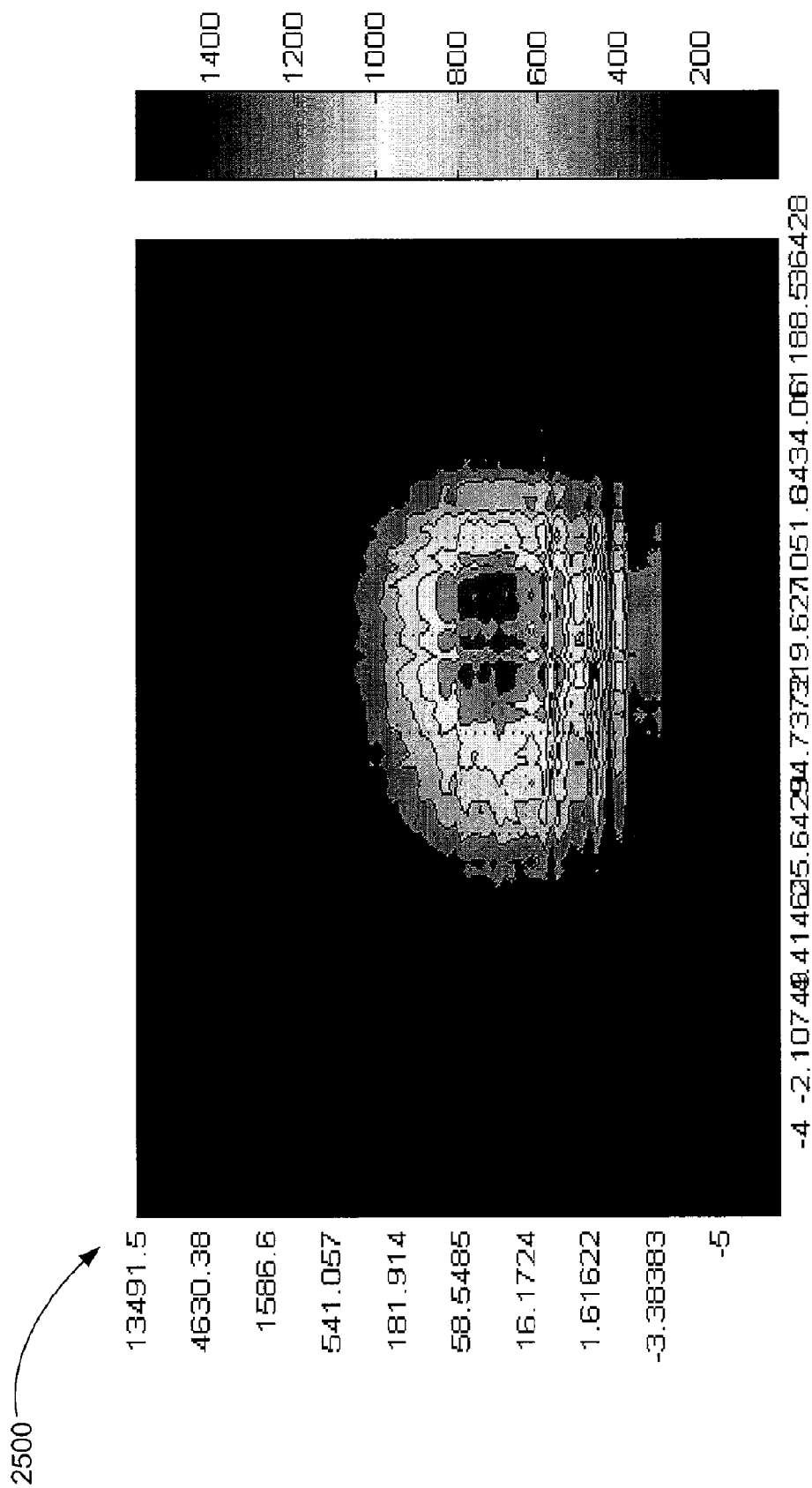

FIGURE 25

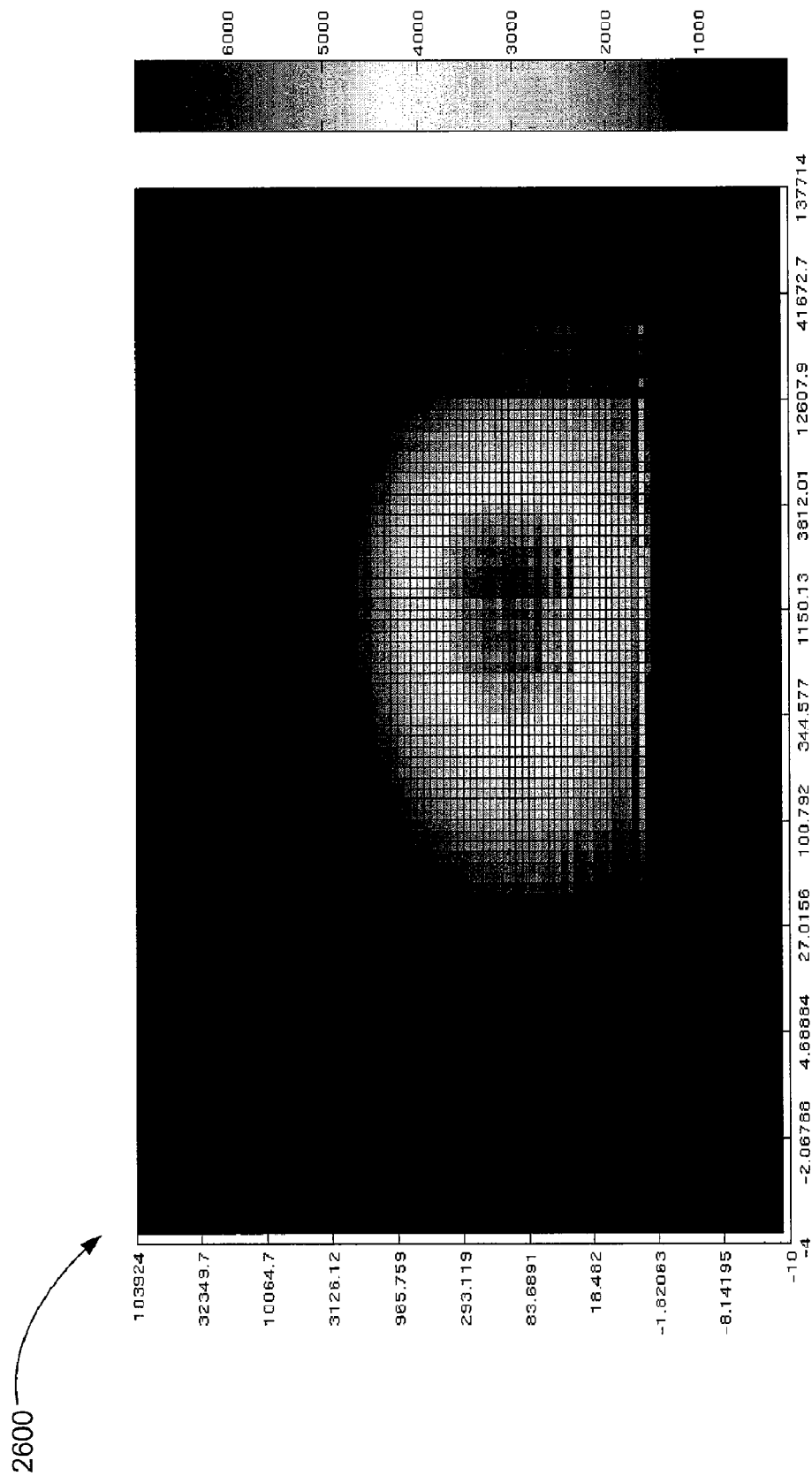

FIGURE 26

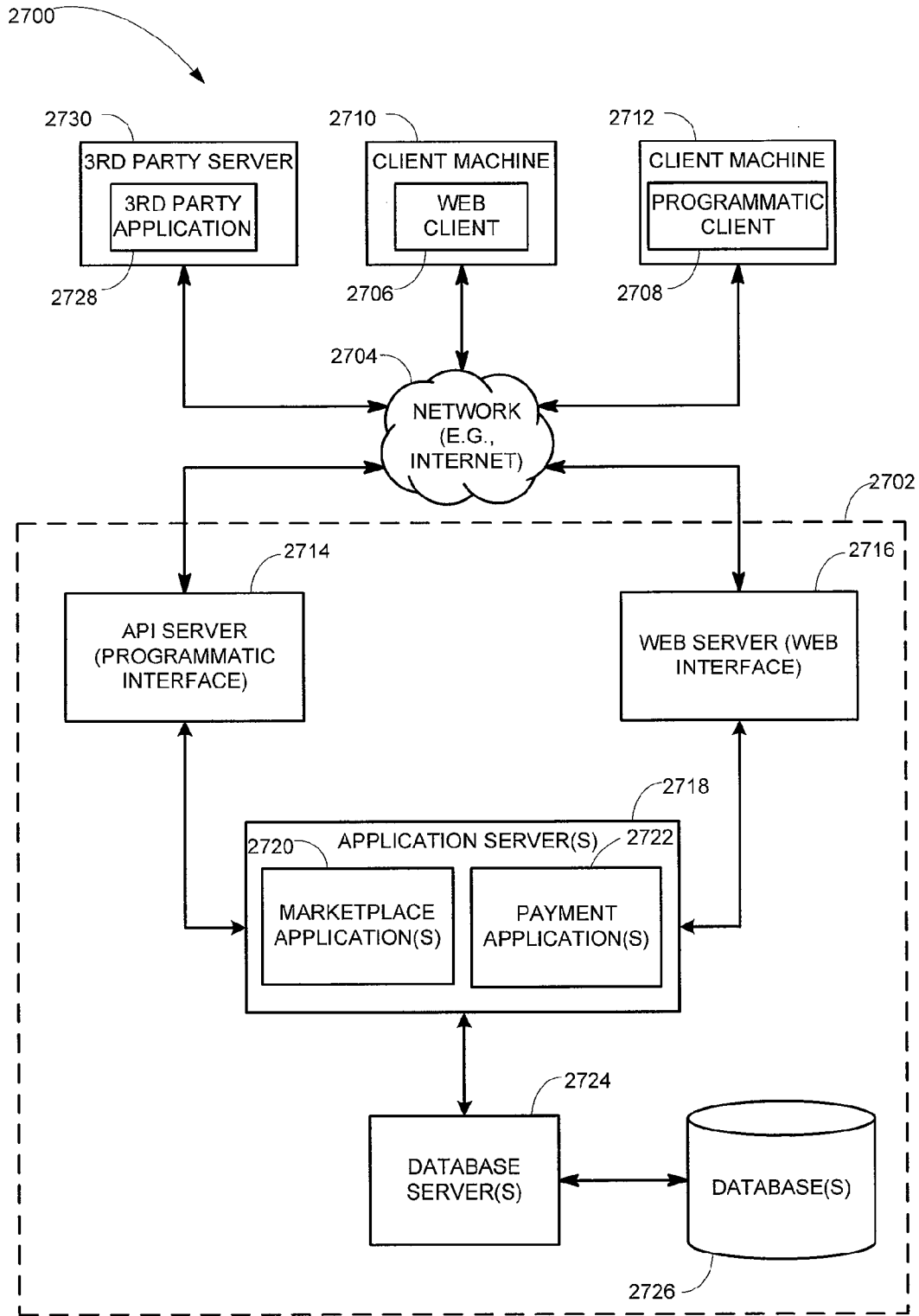

FIGURE 27

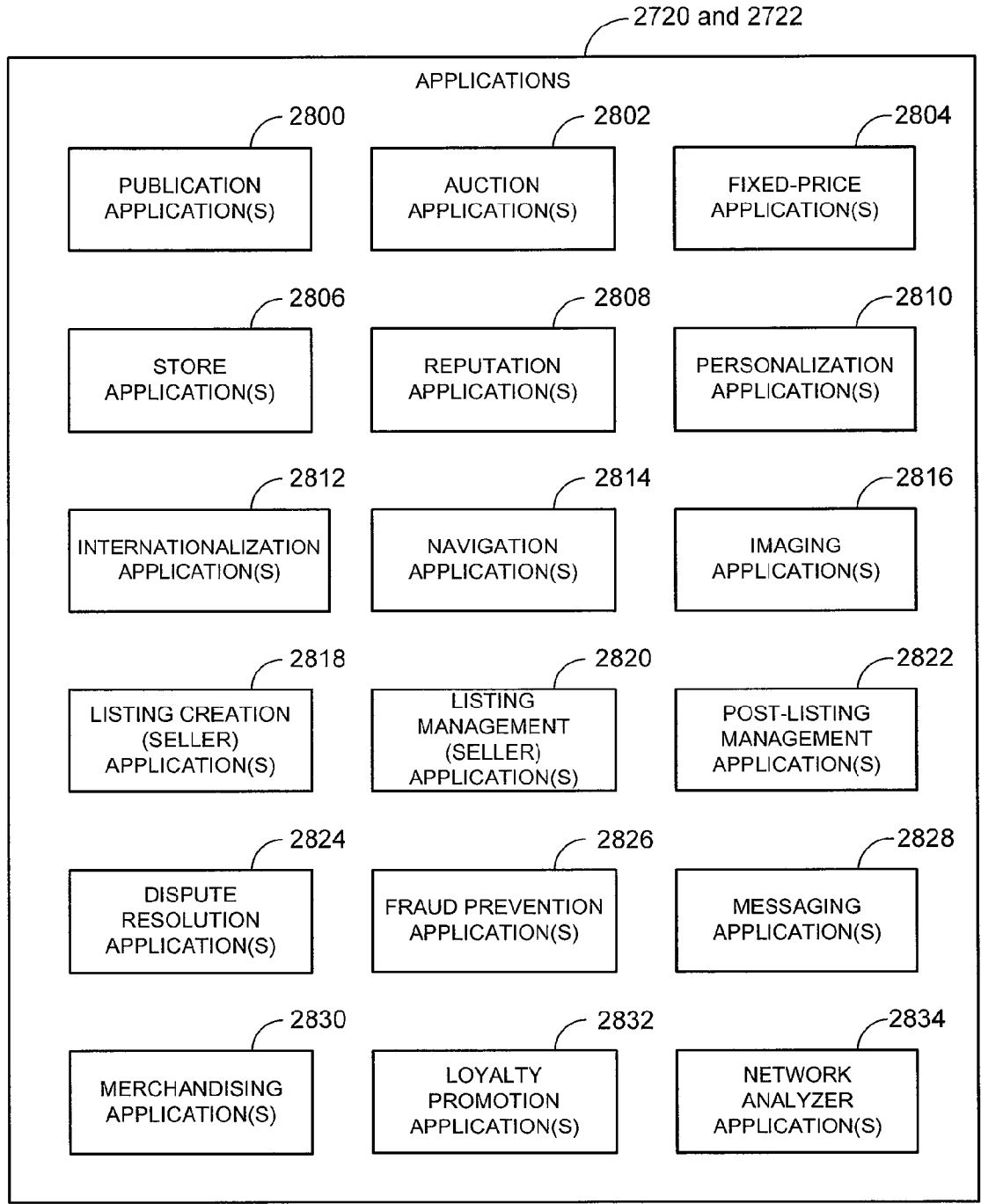

FIGURE 28

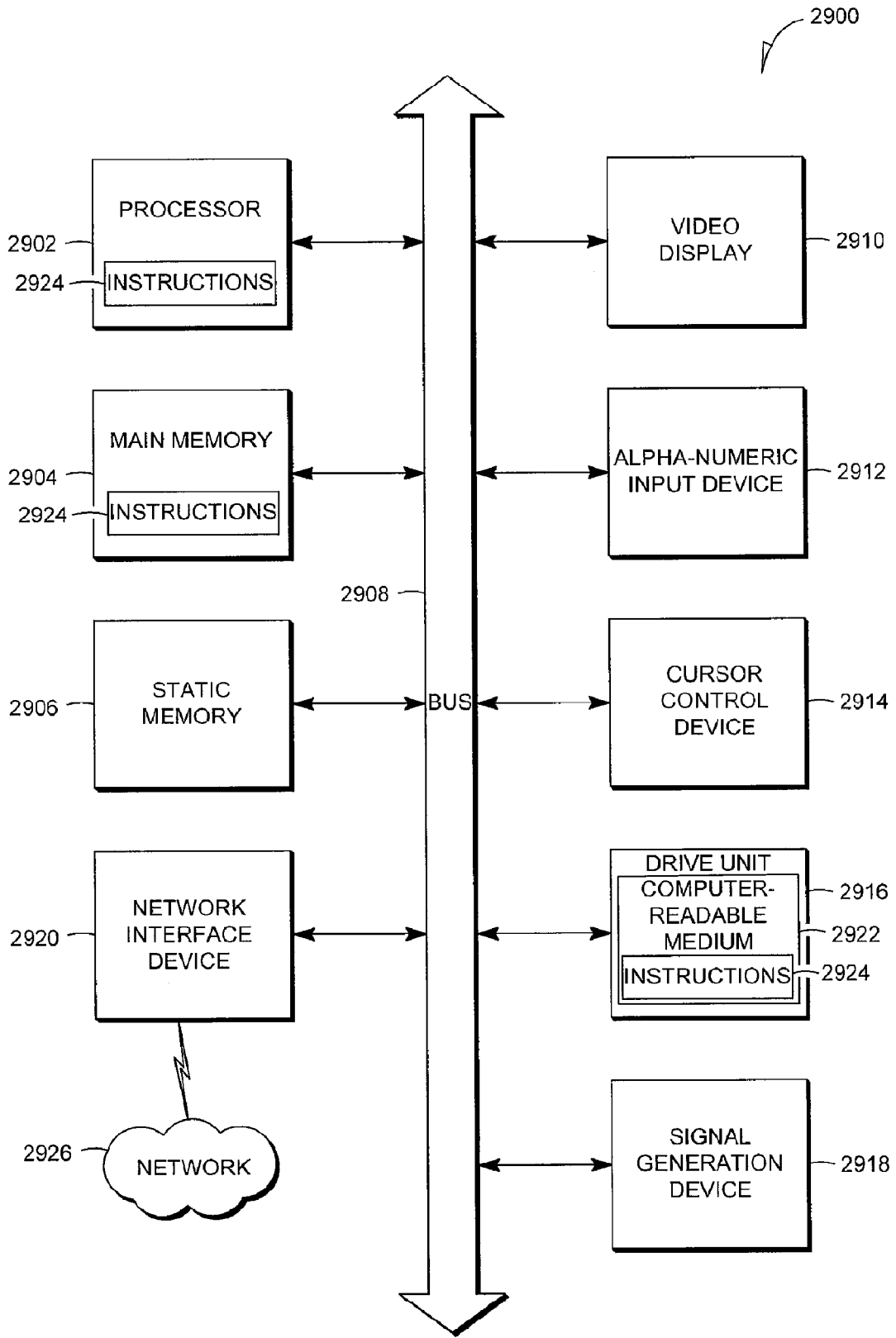

FIGURE 29

METHOD AND SYSTEM FOR SOCIAL NETWORK ANALYSIS

CROSS-REFERENCE TO RELATED APPLICATIONS

[0001] This application claims the benefit of United States Provisional Patent Applications entitled “Social Network Analysis”, Ser. No. 60/971,904, filed Sep. 12, 2007 and entitled “Analysis of a Social Commerce Network”, Ser. No.: 60/984,677, filed Nov. 1, 2007, the entire contents of which are herein incorporated by reference.

BACKGROUND

[0002] The web is evolving from a content and commerce space to a space of social interactions. With the space of social interactions, users may interact with one another in both commercial settings and non-commercial settings (e.g., an information only exchange).

BRIEF DESCRIPTION OF THE DRAWINGS

[0003] Some embodiments are illustrated by way of example and not limitation in the figures of the accompanying drawings in which:

[0004] FIG. 1 is a block diagram of a system, according to an example embodiment;

[0005] FIG. 2 is a block diagram of an example graphing subsystem that may be deployed within the system of FIG. 1 according to an example embodiment;

[0006] FIG. 3 is a block diagram of an example social strength subsystem that may be deployed within the system of FIG. 1 according to an example embodiment;

[0007] FIG. 4 is a block diagram of an example motif subsystem that may be deployed within the system of FIG. 1 according to an example embodiment;

[0008] FIG. 5 is a block diagram of an example plotting subsystem that may be deployed within the system of FIG. 1 according to an example embodiment;

[0009] FIG. 6 is a flowchart illustrating a method for graphing according to an example embodiment;

[0010] FIG. 7 is a flowchart illustrating a method for graph generation according to an example embodiment;

[0011] FIGS. 8A-8E are block diagrams of graphs according to an example embodiment;

[0012] FIG. 9 is a block diagram of a table according to an example embodiment;

[0013] FIGS. 10 and 11 are flowcharts illustrating a method for graph utilization according to an example embodiment;

[0014] FIG. 12 is a flowchart illustrating a method for graph usage according to an example embodiment;

[0015] FIG. 13 is a flowchart illustrating a method for conducting social strength analysis according to an example embodiment;

[0016] FIG. 14 is a flowchart illustrating a method for accessing social network values according to an example embodiment;

[0017] FIG. 15 is a flowchart illustrating a method for social strength utilization according to an example embodiment;

[0018] FIGS. 16 and 17 are block diagrams of charts according to an example embodiment;

[0019] FIG. 18 is a flowchart illustrating a method for conducting social strength analysis according to an example embodiment;

[0020] FIG. 19 is a flowchart illustrating a method for conducting motif analysis according to an example embodiment;

[0021] FIG. 20 is a flowchart illustrating a method for motif utilization according to an example embodiment;

[0022] FIG. 21 is a block diagram of an example motif display according to an example embodiment;

[0023] FIG. 22 is a flowchart illustrating a method for differentiated plotting analysis according to an example embodiment;

[0024] FIG. 23 is a flowchart illustrating a method for differentiated plotting utilization according to an example embodiment;

[0025] FIGS. 24-26 are diagrams of example differentiated plottings according to an example embodiment;

[0026] FIG. 27 is a network diagram depicting a network system, according to one embodiment, having a client server architecture configured for exchanging data over a network;

[0027] FIG. 28 is a block diagram illustrating an example embodiment of multiple network and marketplace applications, which are provided as part of the network-based marketplace; and

[0028] FIG. 29 is a block diagram diagrammatic representation of machine in the example form of a computer system within which a set of instructions for causing the machine to perform any one or more of the methodologies discussed herein may be executed.

DETAILED DESCRIPTION

[0029] Example methods and systems for social network analysis are described. In the following description, for purposes of explanation, numerous specific details are set forth in order to provide a thorough understanding of example embodiments. It will be evident, however, to one skilled in the art that the present invention may be practiced without these specific details.

[0030] In an example embodiment, user interaction data of a time period for a plurality of users in a social network may be accessed. Network analysis may be performed on the user interaction data. A necktie-shaped graph may be generated from the user interaction data in accordance with the performing of the network analysis. The necktie-shaped graph may be utilized for analysis of the social network.

[0031] In an example embodiment, a strongly connected component value, an in-component value, an out-component value, a disconnected component value, a tendril value, and a tube value of a social network for a time period may be accessed. A social strength of the social network for the time period may be calculated by combining the strongly connected component value, the in-component value, the out-component value, the disconnected component value, the tendril value, and the tube value. The social strength of the social network for the time period may be utilized for analysis of the social network. The strongly connected component value may have a greatest weight and the disconnected component value may have the lowest weight in the combining.

[0032] In an example embodiment, a strongly connected component value, an in-component value, an out-component value, a disconnected component value, a tendril value, and a tube value of a social network for a time period may be accessed. A social strength of the social network for the time period may be calculated by combining the strongly connected component value, the in-component value, the out-component value, the disconnected component value, the tendril value, and the tube value. One or more users associated

with the strongly connected component may be identified. The strongly connected component value may be a value of the strongly connected component for the time period. An aspect of the social network associated with the one or more users may be modified. The strongly connected component value, the in-component value, the out-component value, the disconnected component value, the tendrill value, and the tube value of the social network for an additional time period may be accessed. The additional time period may be after the modifying of the aspect. The social strength of the social network for the additional time period may be calculated by combining the strongly connected component value, the in-component value, the out-component value, the disconnected component value, the tendrill value, and the tube value. The social strength of the social network for the time period and the additional time period may be utilized for analysis in accordance with the modifying of the aspect of the social network.

[0033] In an example embodiment, user interaction data associated for a plurality of users for a time period in a social network may be accessed. Network analysis may be performed on the user interaction data. A plurality of example users within the social network may be selected. Each of the example users may be associated with reputation information. A motif may be generated for the plurality of example users for the time period in accordance with the performing of the network analysis. A node of the motif may be associated with a particular example user of the example users. The motif may define an expected relationship between the plurality of example users in the social network. The node of the plurality of example users may be distinguished in accordance with the reputation information of a respective example user. The motif with a plurality of distinguished nodes may be utilized for analysis of the social network.

[0034] In an example embodiment, reputation information associated with a plurality of initiating users and a plurality of responding users in a social network for a time period may be accessed. Interaction frequency data associated with the plurality of initiating users and the plurality of responding users for the time period may be accessed. An aggregated correlation between the plurality of initiating users and the plurality of responding users may be plotted in accordance with the reputation information. The plotting of the aggregated correlation may be differentiated in accordance with the interaction frequency data. The differentiated plotting of the aggregated correlation may be utilized.

[0035] FIG. 1 illustrates an example system 100 in which a community of users may use a number of client machines 102.1-102.*n* to be involved in a social network. The client machine 102 may be a computing system, mobile phone, a personal digital assistant (PDA), a gaming unit, a portable computing unit, and the like. The social network may be a social commerce network over with the users operating the machines may be involved in commercial exchange (e.g., buying or selling). However, other types of social networks (e.g., informational social networks) may also be used.

[0036] In an example embodiment, the social network may be a social structure made of nodes (e.g., individuals or organizations) that are tied by one or more specific types of interdependency including, by way of example, values, visions, idea, commerce, friends, kinship, dislike, conflict, web links, sexual relations, disease transmission, or airline routes. For example, a social commerce network may be a network that includes a commercial interdependency.

[0037] The client machines 102.1-102.*n* may participate in the social network by communicating over a provider network 104 with a network analyzer 106. The provider network 104 may be a Global System for Mobile Communications (GSM) network, an Internet Protocol (IP) network, a Wireless Application Protocol (WAP) network, a WiFi network, or a IEEE 802.11 standards network as well as various combinations thereof. Other conventional and/or later developed wired and wireless networks may also be used.

[0038] The network analyzer 106 may enable the social network to be provided to the users of the client machines 102.1-102.*n*. The network analyzer 106 may be used to analyze the social network by using a graphing subsystem 108, a social strength subsystem 110, a motif subsystem 112, and/or a plotting subsystem 114. Example embodiments of the subsystems 108-114 are described in greater detail below.

[0039] FIG. 2 is an example of a graphing subsystem 108 that may be deployed in the network analyzer 106 of the system 100 (see FIG. 1) or another system according to an example embodiment.

[0040] The graphing subsystem 108 may include a user interaction data access module 202, a network analysis performance module 204, a graph generation module 206, a graph utilization module 208, a reputation information access module 210, a interaction frequency data access module 212, a transactional financial data access module 214, a texture application module 216, a graph analysis module 218, a shape change measurement module 220, a decision making module 222, a network alteration module 224, a graph provider module 226, an aspect alteration module 228, and/or a difference provider module 230. Other modules may also be used.

[0041] The user interaction data access module 202 accesses user interaction data of a time period for a number of users in a social network and/or accesses additional user interaction data associated with the social network during a different time period.

[0042] The network analysis performance module 204 performs network analysis on user interaction data and/or additional user interaction data. The user interaction data may be based on communications between users. For example, the user interaction data may include, by way of example, transactional relationship data that relates to a transaction (e.g., a sale or item exchange) that has occurred between users, communication interaction data that relates to a communication (e.g., an e-mail, an instant message, or a voice over IP call) that has occurred between users, and the like.

[0043] The graph generation module 206 generates a graph (e.g., a necktie-shaped graph) from the user interaction data and/or an additional graph from the additional user interaction data in accordance with the performing of the network analysis.

[0044] The graph utilization module 208 uses a graph and/or an additional graph for analysis of the social network. The reputation information access module 210 accesses reputation information associated with the number of users. The reputation information may include, by way of example, user feedback (e.g., as provided by eBay Inc., of San Jose, Calif.), a rating of a posting, or the like.

[0045] The interaction frequency data access module 212 accesses interaction frequency data associated with the number of users. The transactional financial data access module 214 accesses transactional financial data associated with the number of users.

[0046] The texture application module 216 applies a texture to the graph in accordance with reputation information, interaction frequency data and/or transactional financial data. The graph analysis module 218 analyzes the graph.

[0047] The shape change measurement module 220 measures a shape change between the graph and the additional graph. The decision making module 222 makes a decision regarding the social network in accordance with the analyzing of the graph and/or the measuring of the shape change.

[0048] The network alteration module 224 alters an aspect of the social network in accordance with the making of the decision. The graph provider module 226 provides the graph and/or the additional graph for presentation.

[0049] The aspect alteration module 228 alters an aspect of the social network in accordance with the making of the decision. The difference provider module 230 provides a difference between the graph and the additional graph for presentation.

[0050] FIG. 3 is an example of a social strength subsystem 110 that may be deployed in the network analyzer 106 of the system 100 (see FIG. 1) or another system according to an example embodiment.

[0051] The social strength subsystem 110 may include a user identification module 302, an aspect modification module 304, a value access module 306, a social strength calculation module 308, a social strength provider module 310, a social strength utilization module 312, and/or a difference provider module 314. Other modules may also be used.

[0052] The user identification module 302 identifies one or more users associated with the strongly connected component. The strongly connected component value may be a value of the strongly connected component for the time period. The aspect modification module 304 modifies an aspect of the social network associated with the one or more users.

[0053] The value access module 306 accesses a strongly connected component value, an in-component value, an out-component value, a disconnected component value, a tendril value, and a tube value of a social network for a time period and/or an additional time period.

[0054] The social strength calculation module 308 calculates a social strength of the social network or the social strength of the social network for the categories for the time period and/or an addition time period by combining the strongly connected component value, the in-component value, the out-component value, the disconnected component value, the tendril value, and the tube value. The combination may be by a linear combination, a quadratic equation, or the like.

[0055] The social strength provider module 310 provides the social strength of the social network and/or one or more categories in the social network for the time period and/or an addition time period for presentation. The social strength utilization module 312 uses the social strength of the social network and/or for a number of categories of the social network for the time period and/or the additional time period for analysis of the social network.

[0056] The difference provider module 314 provides a difference between the social strength of the social network for the time period and the additional time period for presentation.

[0057] FIG. 4 is an example of a motif subsystem 112 that may be deployed in the network analyzer 106 of the system 100 (see FIG. 1) or another system according to an example embodiment.

[0058] The motif subsystem 112 may include a data access module 402, a network analysis performance module 404, an example user selection module 406, a motif generation module 408, a node distinguishing module 410, a texture application module 412, a motif provider module 414, a template analysis module 416, and/or a decision making module 418. Other modules may also be used.

[0059] The data access module 402 accesses user interaction data, interaction frequency data, and/or transactional financial data associated for a number of users for a time period in a social network.

[0060] The network analysis performance module 404 performs network analysis on the user interaction data. The example user selection module 406 selects a number of example users within the social network, each of the example users being associated with reputation information.

[0061] The motif generation module 408 generates a motif for the number of example users for the time period in accordance with the performing of the network analysis. The node distinguishing module 410 distinguishes a node of the example users in accordance with the reputation information of a respective example user.

[0062] The texture application module 412 applies a texture to at least one connecting line of the motif in accordance with the interaction frequency data and/or the transactional financial data. The interaction frequency data may include the number of times with which users interacted with one another.

[0063] The motif provider module 414 provides the motif with the number of distinguished nodes for presentation. The template analysis module 416 analyzes a template including the motif and a number of additional motifs. The decision making module 418 makes a decision regarding the social network in accordance with the analyzing of the template.

[0064] FIG. 5 is an example of a plotting subsystem 500 that may be deployed in the network analyzer 106 of the system 100 (see FIG. 1) or another system according to an example embodiment.

[0065] The plotting subsystem 500 may include a reputation information access module 502, a interaction frequency data access module 504, an aggregated correlation plotting module 506, a plotting differentiation module 508, a plotting provider module 510, and/or a plotting utilization module 512. Other modules may also be used.

[0066] The reputation information access module 502 accesses reputation information associated with initiating users (e.g., buyers) and responding users (e.g., sellers) in a social network for a time period and/or an additional time period.

[0067] The interaction frequency data access module 504 accesses interaction frequency data associated with the initiating users and the responding users for the time period and/or the additional time period.

[0068] The aggregated correlation plotting module 506 plots an aggregated correlation between the initiating users and the receiving users in accordance with the reputation information and/or the assorted initiating users and the assorted initiating users in accordance with the reputation information. The assorted initiating users may include one or

more of the initiating users. The assorted receiving users may include one or more of the receiving users.

[0069] The plotting differentiation module 508 differentiates the plotting of the aggregated correlation in accordance with the interaction frequency data. The plotting provider module 510 provides the differentiated plotting of the aggregated correlation for presentation. The plotting utilization module 512 uses the differentiated plotting of the aggregated correlation for the time period and the additional time period for the analysis of the social network.

[0070] Necktie-Shape Graphing

[0071] FIG. 6 illustrates a method 600 for graphing according to an example embodiment. The method 600 may be performed by the network analyzer 106 (see FIG. 1) in the system 100 or another system.

[0072] User interaction data of a time period for users in a social network (e.g., a social commerce network) is accessed at block 602. The user interaction data may be associated with a single transaction category or multiple transaction categories.

[0073] Network analysis is performed on the user interaction data at block 604. A graph is generated from the user interaction data in accordance with the performing of the network analysis at block 606. The graph may be a necktie-shaped graph, a bowtie shaped graph, or be in a different shape. In addition, the graphs may have different sized dimensions based on a particular representation.

[0074] At decision block 608, a determination may be made whether to apply a texture to the graph. If a determination is made to apply a texture, additional user data may be accessed at block 610 and a texture may be applied to the graph in accordance with the additional user data at block 612. The additional user data may include, by way of example, interaction frequency data, reputation information, transactional financial data, or other data associated with the users.

[0075] The texture applied to the graph may include colorization, striping, and the like. The texture may better enable a user to more easily understand more about the relationship of the users reflected in the graph. For example, users in a particular component of the graph may be making a large number of interactions or a small number of interactions.

[0076] If a determination is made at decision block 608 not to apply a texture or upon completion of the operations at block 612, the method 600 may proceed to block 614.

[0077] The graph is utilized for analysis of the social network at block 614. For example, the graph may be provided for presentation.

[0078] FIG. 7 illustrates a method 700 for graph generation according to an example embodiment. The method 700 may be performed at block 604 or otherwise performed.

[0079] A strongly connected component of the graph is generated in accordance with the performing of the network analysis at block 702. An in-component of the graph is generated in accordance with the performing of the network analysis at block 704.

[0080] An out-component of the graph is generated in accordance with the performing of the network analysis at block 706. The in-component of the graph may be smaller than the out-component of the graph.

[0081] At block 708, a tube is used to connect the in-component to the out-component. One or more tendrils may be generated in accordance with the performing of the network analysis at block 710. The one or more tendrils may be connected to the in-component or the out-component.

[0082] A disconnected part may be generated in accordance with the performing of the network analysis at block 712. The disconnected part may be disconnected from the strongly connect component, the in-component, and the out-component in the graph.

[0083] FIG. 8A is a diagram of an example necktie-shaped graph 800 according to an example embodiment. The necktie-shaped graph 800 is an example representation of a graph that may be generated in accordance with the method 700 (see FIG. 7). However, other representations of the same or different types of graphs may also be generated.

[0084] A strongly connected component 802 may be connected to an in-component 804 and an out-component 806. While the representation of the example necktie-shaped graph 800 reflects a strongly connected component value of 5.83%, an in-component value of 3.03%, and an out-component value of 65.83%, other values may be used in other representations.

[0085] The in-component 804 and the out-component 806 may be connected through a tube 808. The tube value in the presentation representation is 0.64%, however other values may be used in other representations.

[0086] One or more tendrils 810.1-810.6 may be connected to the in-component 804 or the out-component 806. However, a different number of tendrils 810.1-810.6 may be used in a different representation. The tendril value in the presentation representation is 23.59%, however other values may be used in other representations.

[0087] A disconnected component 812 may not be connected to the strongly connected component 802, the in-component 804, the out-component 806, the tube 808, and/or the tendrils 810.1-810.6. The disconnected component value in the presentation representation is 1.09%, however other values may be used in other representations.

[0088] FIGS. 8B-8E are diagrams of example graphs 820, 840, 860, 880 according to example embodiments. Each of the graphs 820, 840, 860, 880 include a strongly connected component, an in-component, an out-component, a tube, one or more tendrils, and a disconnected component. The graph 820 may represent an Antiques category, the graph 840 may represent a Collectibles category, the graph 860 may represent a Sports Memorabilia and Cards category, and the graph 880 may represent a Stamps category.

[0089] FIG. 9 illustrates a block diagram of an example table 900 according to an example embodiment. The table 900 is an example representation that may reflect a distribution of various components of a graph (e.g., the necktie-shaped graph 800 of FIG. 8). However, other representations containing different values and/or components may also be used.

[0090] The size row 902 of the table 900 may reflect a size percentage of various components of a graph. The average feedback row 904 may contain values that reflect an average feedback store of users associated with a particular component. The purchases row 906 may contain values that reflect an average and percentage of purchases associated with a particular component. The sales row 908 may contain values that reflect an average and percentage of sales associated with a particular component. The columns 910-029 are associated with particular components of a graph.

[0091] FIG. 10 illustrates a method 1000 for graph utilization according to an example embodiment. The method 1000 may be performed at block 614 or otherwise performed.

[0092] The graph is analyzed at block 1002. A decision regarding the social network is made in accordance with the analyzing of the graph at block 1004. For example, an area of weakness may be identified in the social network.

[0093] At block 1006, an aspect of the social network is altered in accordance with the making of the decision.

[0094] FIG. 11 illustrates a method 1100 for graph utilization according to an example embodiment. The method 1100 may be performed at block 614 or otherwise performed.

[0095] At block 1102, additional user interaction data associated with the social network is accessed during a different time period. Network analysis is performed on the additional user interaction data at block 1104.

[0096] An additional graph is generated from the additional user interaction data in accordance with the performing of the network analysis at block 1106.

[0097] At block 1108, the graph and the additional graph are used for analysis of the social network. For example, the graph and the additional graph may be provided for presentation and/or a difference between the graph and the additional graph may be provided for presentation.

[0098] FIG. 12 illustrates a method 1200 for graph usage according to an example embodiment. The method 1200 may be performed at block 1108 or otherwise performed.

[0099] A shape change between the graph and the additional graph is measured at block 1202. A decision regarding the social network is made in accordance with the measuring of the shape change at block 1204. For example, the decision may include providing one or more users with an incentive to become associated with a component, to exclude users from the social network, or the like. An aspect of the social network is altered in accordance with the making of the decision at block 1206.

[0100] Social Strength Analysis

[0101] FIG. 13 illustrates a method 1300 for conducting social strength analysis according to an example embodiment. The method 1300 may be performed by the network analyzer 106 (see FIG. 1) in the system 100 or another system.

[0102] A strongly connected component value, an in-component value, an out-component value, a disconnected component value, a tendrill value, and/or a tube value of a social network (e.g., a social commerce network) for a time period is accessed at block 1302.

[0103] At block 1304, social strength of the social network is calculated for the time period by combining the strongly connected component value, the in-component value, the out-component value, the disconnected component value, the tendrill value, and/or the tube value. The social strength may be calculated for the entire social network and/or a number of categories in the social network for the time period. The combination may be through a linear combination or a different type of function.

[0104] The strongly connected component value may have greatest weight in the combination. The disconnected component value may have the lowest weight in the combination. The weight of the in-component, the out-component, and the tube may be equally weighted. For example, the weight of the strongly connected component value may be double the weight of the in-component and the out-component and the weight of the disconnected component value may be half the weight of the in-component and the out-component in the linear combination. However, other weightings in the combination may also be used.

[0105] The social strength of the social network for the time period is utilized for analysis of the social network at block 1306. For example, the social strength of the social network for the time period may be provided for presentation.

[0106] FIG. 14 illustrates a method 1400 for accessing social network values according to an example embodiment. The method 1400 may be performed at block 614, block 1302, or otherwise performed.

[0107] A strongly connected component value is determined in accordance with a graph percentage of a strongly connected component of the social network at block 1402.

[0108] An in-component value is determined in accordance with the graph percentage of an in-component of the social network at block 1404. An out-component value is determined in accordance with the graph percentage of an out-component of the social network at block 1406. A disconnected component value may be determined in accordance with the graph percentage of a disconnected component of the social network at block 1408.

[0109] A tendrill value may be determined in accordance with the graph percentage of one or more tendrills of the social network at block 1410. A tube value may be determined in accordance with the graph percentage of a tube of the social network at block 1412.

[0110] FIG. 15 illustrates a method 1500 for accessing social strength utilization according to an example embodiment. The method 1500 may be performed at block 1306 or otherwise performed.

[0111] The strongly connected component value, the in-component value, the out-component value, the disconnected component value, the tendrill value, and/or the tube value of the social network is accessed for an additional time period at block 1502.

[0112] At block 1504, the social strength of the social network is calculated for the additional time period by taking the linear combination of the strongly connected component value, the in-component value, the out-component value, the disconnected component value, the tendrill value, and/or the tube value. The social strength may be calculated for the entire social network and/or a number of categories in the social network for the additional time period.

[0113] The social strength of the social network for the time period and the additional time period is used for analysis of the social network at block 1506. For example, the social strength of the social network for the time period and the additional time period and/or a difference between the social strength of the social network for the time period and the additional time period may be provided for presentation. The provided social strength may be for one or more categories of the social network or the entire social network.

[0114] FIG. 16 is a block diagram of a chart 1600 according to an example embodiment. The chart 1600 is an example comparison of the network shapes of multiple categories of an example social network. For example, the categories reflected in the social network of the chart 1600 include an entire network, Antiques, Art, Baby, Books, Business & Industrial, Cameras & Photo, Clothing, Shoes & Apparel, Collectibles, Computers & Networking, Consumer Electronics, Crafts, Dolls & Bears, DVDs & Movies, Entertainment Memorabilia, Everything Else, Gift Certificates, Health & Beauty, Home & Garden, Jewelry & Watches, Live Auctions, Music, Musical Instruments, Pottery & Glass, Real Estate, Specialty Services, Sporting Goods, Sports Memorabilia & Cards, Stamps, Tickets, Toys & Hobbies, Travel, and Video Games.

Other social networks may be categorized with a different number of categories and/or different types of categories.

[0115] FIG. 17 is a block diagram of a chart 1700 according to an example embodiment. The chart 1700 is an example comparison of the social strength of multiple categories in a social network. However, other comparisons may also be used. For example, other social networks may be categorized with a different number of categories and/or different types of categories.

[0116] FIG. 18 illustrates a method 1800 for conducting social strength analysis according to an example embodiment. The method 1800 may be performed by the network analyzer 106 (see FIG. 1) in the system 100 or another system.

[0117] A strongly connected component value, an in-component value, an out-component value, a disconnected component value, a tendrill value, and/or a tube value of a social network for a time period is accessed at block 1802.

[0118] At block 1804, a social strength of the social network for the time period is calculated by taking a linear combination of the strongly connected component value (e.g., a value of a strongly connected component), the in-component value, the out-component value, the disconnected component value, the tendrill value, and the tube value.

[0119] One or more users associated with the strongly connected component are identified at block 1806. An aspect of the social network associated with the one or more users may be modified at block 1808. For example, the one or more users may be provided with an incentive to have a number of other users utilize a feature of the social network and/or with a designated status in the social network. Other aspects of the social network may also be modified.

[0120] At block 1810, the strongly connected component value, the in-component value, the out-component value, the disconnected component value, the tendrill value, and the tube value of the social network may be accessed for an additional time period. The additional time period may be after the modifying of the aspect performed at the block 1808.

[0121] At block 1812, the social strength of the social network is calculated for the additional time period by taking the linear combination of the strongly connected component value, the in-component value, the out-component value, the disconnected component value, the tendrill value, and/or the tube value.

[0122] The social strength of the social network for the time period and the additional time period is used for analysis at block 1814.

[0123] Motifs

[0124] FIG. 19 illustrates a method 1900 for conducting motif analysis according to an example embodiment. The method 1900 may be performed by the network analyzer 106 (see FIG. 1) in the system 100 or another system.

[0125] User interaction data associated for users for a time period in a social network (e.g., a social commerce network) is accessed at block 1902. Network analysis is performed on the user interaction data at block 1904.

[0126] Example users within the social network are selected at block 1906. The example users may be associated with reputation information (e.g., user feedback).

[0127] A motif for the example users for the time period is generated in accordance with the performing of the network analysis at block 1908. A node of the motif may be associated with an example user. The motif may define an expected relationship between a number of example users in the social network. For example, a four node motif may be generated.

[0128] The node of the example users may be distinguished in accordance with the reputation information of a respective example user at block 1910. For example, the node of the example users may be colored in accordance with the reputation information.

[0129] At decision block 1912, a determination may be made whether to apply a texture to the motif. If a determination is made to apply a texture, additional user data may be accessed at block 1914 and the texture may be applied to one or more connected lines of the motif in accordance with the additional user data at block 1916. For example, the additional user data may include interaction frequency data and/or transaction financial data associated with the users. If a determination is made not to apply the texture at decision block 1912 or upon completion of the operations at block 1916, the method 1900 may proceed to the block 1918.

[0130] The motif with the distinguished nodes may be utilized for analysis of the social network at block 1918. For example, the motif with the distinguished nodes may be provided for presentation.

[0131] FIG. 20 illustrates a method 2000 for motif utilization according to an example embodiment. The method 2000 may be performed at block 1918 or otherwise performed.

[0132] The method 2000 may be performed at block 1918 or otherwise performed. A template including the motif and a number of additional motifs is analyzed at block 2002.

[0133] A decision regarding the social network is made in accordance with the analyzing of the template at block 2004. At block 2006, at least one aspect of the social network is altered in accordance with the making of the decision.

[0134] FIG. 21 is a block diagram of example motif display 2100 according to an example embodiment. The motif display 2100 is an example representation of four node motifs from two categories of a social network. However, motifs may be made for other categories of the social network or the entire social network. Motifs containing a different number of nodes may also be used.

[0135] The motif display 2100 includes a number of motifs 2126-2144 for a first category 2102 and a number of motifs 2146 for a second category 2164.

[0136] A distinguishing legend 2106 may include a series of distinguishing levels 2180-2124 that reflect different reputation information associated with users of the motifs 2126-2164. For example, the nodes of the motif 2126 includes a first node with a distinguishing level 2118, a second node with a distinguishing level 2120, a third node with a distinguishing level 2122, and a fourth node with a distinguishing level 2124.

[0137] Differentiated Plotting

[0138] FIG. 22 illustrates a method 2200 for differentiated plotting analysis according to an example embodiment. The method 2200 may be performed by the network analyzer 106 (see FIG. 1) in the system 100 or another system.

[0139] Reputation information associated with a number of initiating users and a number of responding users in a social network for a time period is accessed at block 2202.

[0140] Interaction frequency data associated with the initiating users and the responding users for the time period is accessed at block 2204. An aggregated correlation between the initiating users and the responding users is plotted in accordance with the reputation information at block 2206.

[0141] The plotting of the aggregated correlation is differentiated in accordance with the interaction frequency data at block 2208. The differentiated plotting of the aggregated

correlation is utilized at block **2210**. For example, the differentiated plotting of the aggregated correlation may be provided for presentation.

[0142] In an example embodiment, the differentiated plotting may be used to determine users' tendency to interact with others with respect of their reputation information (e.g., feedback scores). For example, the differentiated plotting may help identify whether users with high reputation information (e.g., high feedback scores) tend to interact with other users that also have high reputation information. Assortative mixing may be used to show the extent to which nodes (e.g., users) connect preferentially to other nodes with similar characteristics.

[0143] FIG. 23 illustrates a method **2300** for differentiated plotting utilization according to an example embodiment. The method **2300** may be performed at block **2210** or otherwise performed.

[0144] Reputation information associated with assorted initiating users and a assorted responding users in a social network for an additional time period is accessed at block **2302**.

[0145] At block **2304**, interaction frequency data associated with the assorted initiating users and the assorted responding users for the additional time period is accessed.

[0146] The plotting of the aggregated correlation of the additional time period is differentiated in accordance with the interaction frequency data at block **2206**.

[0147] The aggregated correlation between the assorted initiating users and the assorted initiating users is plotted in accordance with the reputation information at block **2308**.

[0148] The differentiated plotting of the aggregated correlation for the time period and the additional time period is used for the analysis of the social network at block **2310**.

[0149] FIGS. 24-26 are diagrams of example differentiated plottings **2400**, **2500**, **2600**. The differentiated plottings **2400**, **2500**, **2600** are example representations of differentiated plottings that may be plotted in accordance with the method **2200** and/or the method **2300**. However, other representations of the differentiated plottings may also be used.

[0150] The differentiated plottings **2400**, **2500**, **2600** plot the aggregated correlation between initiating users' reputation information (e.g., sellers' feedback scores) and receiving users' reputation information (e.g., buyers' feedback scores).

[0151] The x axis of the differentiated plottings **2400**, **2500**, **2600** denotes users' reputation information, and the y axis denotes receiving users reputation information. The axes of the differentiated plottings **2400**, **2500**, **2600** may be logarithmically binned.

[0152] The differentiation on the differentiated plottings **2400**, **2500**, **2600** based on interaction frequency data may be color. For example, a score of zero to two hundred is reflected by a dark blue color, a score of two hundred to four hundred is reflect by a medium blue color, a score of four hundred to six hundred is reflected by a light blue color, a score of six hundred to eight hundred is reflected by a blue/green color, a score of eight hundred to one thousand is reflected by a green/yellow color, a score of one thousand to one thousand two hundred is reflect by a yellow/orange color, a score of one thousand two hundred to one thousand four hundred is reflect by an orange/red color, and one thousand four hundred is reflected by a red color. The colors in the legend are shown in the differentiated plottings **2400**, **2500**, **2600** as being gradient. However other types of representations of the differentiation may be used.

[0153] The color of each block of the differentiated plottings **2400**, **2500**, **2600** may be determined by the number of interactions (e.g., transactions) that happed between pairs of users with corresponding reputation information.

[0154] The differentiated plotting **2400** may represent a number of transactions of a particular category (e.g., crafts) in which most interactions (e.g., transactions) are between initiating users (e.g., buyers) that have a feedback score between twenty and five hundred and responding users (e.g., sellers) that have a feedback score between ten and ninety.

[0155] The differentiated plotting **2500** may represent a number of transactions of a particular category in which most interactions are between initiating users that have a feedback score between sixteen and sixty and responding users that have a feedback score between one hundred fifty and two seven hundred.

[0156] The differentiated plotting **2600** may represent a number of transactions of a particular category (e.g., collectables) in which most interactions are between initiating users that have a feedback score between ten and seventy and responding users that have a feedback score between one hundred and three thousand.

[0157] Platform

[0158] FIG. 27 is a network diagram depicting a client-server system **2700**, within which one example embodiment may be deployed. By way of example, a network **2704** may include the functionality of the provider network **104**, the network analyzer **106** may be deployed within an application server **2718**, and the client machines **102.1-102.n** may include the functionality of a client machine **2710** or a client machine **2712**. The system **100** may also be deployed in other systems.

[0159] A networked system **2702**, in the example forms of a network-based marketplace or publication system, provides server-side functionality, via a network **2704** (e.g., the Internet or Wide Area Network (WAN)) to one or more clients. FIG. 27 illustrates, for example, a web client **2706** (e.g., a browser, such as the Internet Explorer browser developed by Microsoft Corporation of Redmond, Wash. State), and a programmatic client **2708** executing on respective client machines **2710** and **2712**.

[0160] An Application Program Interface (API) server **2714** and a web server **2716** are coupled to, and provide programmatic and web interfaces respectively to, one or more application servers **2718**. The application servers **2718** host one or more marketplace applications **2720** and authentication providers **2722**. The application servers **2718** are, in turn, shown to be coupled to one or more databases servers **2724** that facilitate access to one or more databases **2726**.

[0161] The marketplace applications **2720** may provide a number of marketplace functions and services to users that access the networked system **2702**. The authentication providers **2722** may likewise provide a number of payment services and functions to users. The authentication providers **2722** may allow users to accumulate value (e.g., in a commercial currency, such as the U.S. dollar, or a proprietary currency, such as "points") in accounts, and then later to redeem the accumulated value for products (e.g., goods or services) that are made available via the marketplace applications **2720**. While the marketplace and authentication providers **2720** and **2722** are shown in FIG. 27 to both form part of the networked system **2702**, in alternative embodiments

the authentication providers 2722 may form part of a payment service that is separate and distinct from the networked system 2702.

[0162] Further, while the system 2700 shown in FIG. 27 employs a client-server architecture, the present invention is of course not limited to such an architecture, and could equally well find application in a distributed, or peer-to-peer, architecture system, for example. The various marketplace and authentication providers 2720 and 2722 could also be implemented as standalone software programs, which need not have networking capabilities.

[0163] The web client 2706 accesses the various marketplace and authentication providers 2720 and 2722 via the web interface supported by the web server 2716. Similarly, the programmatic client 2708 accesses the various services and functions provided by the marketplace and authentication providers 2720 and 2722 via the programmatic interface provided by the API server 2714. The programmatic client 2708 may, for example, be a seller application (e.g., the TurboLister™ application developed by eBay Inc., of San Jose, Calif.) to enable sellers to author and manage listings on the networked system 2702 in an off-line manner, and to perform batch-mode communications between the programmatic client 2708 and the networked system 2702.

[0164] FIG. 27 also illustrates a third party application 2728, executing on a third party server machine 2730, as having programmatic access to the networked system 2702 via the programmatic interface provided by the API server 2714. For example, the third party application 2728 may, utilizing information retrieved from the networked system 2702, support one or more features or functions on a website hosted by the third party. The third party may, for example, provide one or more promotional, marketplace or payment functions that are supported by the relevant applications of the networked system 2702.

[0165] FIG. 28 is a block diagram illustrating multiple applications 2720 and 2722 that, in one example embodiment, are provided as part of the networked system 2702 (see FIG. 27). The applications 2720 may be hosted on dedicated or shared server machines (not shown) that are communicatively coupled to enable communications between server machines. The applications themselves are communicatively coupled (e.g., via appropriate interfaces) to each other and to various data sources, so as to allow information to be passed between the applications or so as to allow the applications to share and access common data. The applications may furthermore access one or more databases 2726 via the database servers 2724.

[0166] The networked system 2702 may provide a number of publishing, listing and price-setting mechanisms whereby a seller may list (or publish information concerning) goods or services for sale, a buyer can express interest in or indicate a desire to purchase such goods or services, and a price can be set for a transaction pertaining to the goods or services. To this end, the marketplace applications 2720 are shown to include at least one publication application 1110 and one or more auction applications 2802 which support auction-format listing and price setting mechanisms (e.g., English, Dutch, Vickrey, Chinese, Double, Reverse auctions etc.). The various auction applications 2802 may also provide a number of features in support of such auction-format listings, such as a reserve price feature whereby a seller may specify a reserve price in connection with a listing and a proxy-bidding feature whereby a bidder may invoke automated proxy bidding.

[0167] A number of fixed-price applications 2804 support fixed-price listing formats (e.g., the traditional classified advertisement-type listing or a catalogue listing) and buyout-type listings. Specifically, buyout-type listings (e.g., including the Buy-It-Now (BIN) technology developed by eBay Inc., of San Jose, Calif.) may be offered in conjunction with auction-format listings, and allow a buyer to purchase goods or services, which are also being offered for sale via an auction, for a fixed-price that is typically higher than the starting price of the auction.

[0168] Store applications 2806 allow a seller to group listings within a “virtual” store, which may be branded and otherwise personalized by and for the seller. Such a virtual store may also offer promotions, incentives and features that are specific and personalized to a relevant seller.

[0169] Reputation applications 2808 allow users that transact, utilizing the networked system 2702, to establish, build and maintain reputations, which may be made available and published to potential trading partners. Consider that where, for example, the networked system 2702 supports person-to-person trading, users may otherwise have no history or other reference information whereby the trustworthiness and credibility of potential trading partners may be assessed. The reputation applications 2808 allow a user, for example through feedback provided by other transaction partners, to establish a reputation within the networked system 2702 over time. Other potential trading partners may then reference such a reputation for the purposes of assessing credibility and trustworthiness.

[0170] Personalization applications 2810 allow users of the networked system 2702 to personalize various aspects of their interactions with the networked system 2702. For example a user may, utilizing an appropriate personalization application 2810, create a personalized reference page at which information regarding transactions to which the user is (or has been) a party may be viewed. Further, a personalization application 2810 may enable a user to personalize listings and other aspects of their interactions with the networked system 2702 and other parties.

[0171] The networked system 2702 may support a number of marketplaces that are customized, for example, for specific geographic regions. A version of the networked system 2702 may be customized for the United Kingdom, whereas another version of the networked system 2702 may be customized for the United States. Each of these versions may operate as an independent marketplace, or may be customized (or internationalized and/or localized) presentations of a common underlying marketplace. The networked system 2702 may accordingly include a number of internationalization applications 2812 that customize information (and/or the presentation of information) by the networked system 2702 according to predetermined criteria (e.g., geographic, demographic or marketplace criteria). For example, the internationalization applications 2812 may be used to support the customization of information for a number of regional websites that are operated by the networked system 2702 and that are accessible via respective web servers 2716.

[0172] Navigation of the networked system 2702 may be facilitated by one or more navigation applications 2814. For example, a search application (as an example of a navigation application) may enable key word searches of listings published via the networked system 2702. A browse application may allow users to browse various category, catalogue, or system inventory structures according to which listings may

be classified within the networked system **2702**. Various other navigation applications may be provided to supplement the search and browsing applications.

[0173] In order to make listings available via the networked system **2702** as visually informing and attractive as possible, the marketplace applications **2720** may include one or more imaging applications **2816** utilizing which users may upload images for inclusion within listings. An imaging application **2816** also operates to incorporate images within viewed listings. The imaging applications **2816** may also support one or more promotional features, such as image galleries that are presented to potential buyers. For example, sellers may pay an additional fee to have an image included within a gallery of images for promoted items.

[0174] Listing creation applications **2818** allow sellers conveniently to author listings pertaining to goods or services that they wish to transact via the networked system **2702**, and listing management applications **2820** allow sellers to manage such listings. Specifically, where a particular seller has authored and/or published a large number of listings, the management of such listings may present a challenge. The listing management applications **2820** provide a number of features (e.g., auto-relisting, inventory level monitors, etc.) to assist the seller in managing such listings. One or more post-listing management applications **2822** also assist sellers with a number of activities that typically occur post-listing. For example, upon completion of an auction facilitated by one or more auction applications **2802**, a seller may wish to leave feedback regarding a particular buyer. To this end, a post-listing management application **2822** may provide an interface to one or more reputation applications **2808**, so as to allow the seller conveniently to provide feedback regarding multiple buyers to the reputation applications **2808**.

[0175] Dispute resolution applications **2824** provide mechanisms whereby disputes arising between transacting parties may be resolved. For example, the dispute resolution applications **2824** may provide guided procedures whereby the parties are guided through a number of steps in an attempt to settle a dispute. In the event that the dispute cannot be settled via the guided procedures, the dispute may be escalated to a merchant mediator or arbitrator.

[0176] A number of fraud prevention applications **2826** implement fraud detection and prevention mechanisms to reduce the occurrence of fraud within the networked system **2702**.

[0177] Messaging applications **2828** are responsible for the generation and delivery of messages to users of the networked system **2702**, such messages for example advising users regarding the status of listings at the networked system **2702** (e.g., providing “outbid” notices to bidders during an auction process or to provide promotional and merchandising information to users). Respective messaging applications **2828** may utilize any one have a number of message delivery networks and platforms to deliver messages to users. For example, messaging applications **2828** may deliver electronic mail (e-mail), instant message (IM), Short Message Service (SMS), text, facsimile, or voice (e.g., Voice over IP (VoIP)) messages via the wired (e.g., the Internet), Plain Old Telephone Service (POTS), or wireless (e.g., mobile, cellular, WiFi, WiMAX) networks.

[0178] Merchandising applications **2830** support various merchandising functions that are made available to sellers to enable sellers to increase sales via the networked system **2702**. The merchandising applications **2830** also operate the

various merchandising features that may be invoked by sellers, and may monitor and track the success of merchandising strategies employed by sellers.

[0179] The networked system **2702** itself, or one or more parties that transact via the networked system **2702**, may operate loyalty programs that are supported by one or more loyalty/promotions applications **2832**. For example, a buyer may earn loyalty or promotions points for each transaction established and/or concluded with a particular seller, and may be offered a reward for which accumulated loyalty points can be redeemed.

[0180] A network analyzer application **2834** may analyze the social network amount a number of users of the system **100**.

[0181] FIG. **29** shows a diagrammatic representation of machine in the example form of a computer system **2900** within which a set of instructions may be executed causing the machine to perform any one or more of the methods, processes, operations, or methodologies discussed herein. The network analyzer **106** may operate on or more computer systems **2900** and/or the client machines **102.1-102.n** may include the functionality of the computer system **2900**.

[0182] In an example embodiment, the machine operates as a standalone device or may be connected (e.g., networked) to other machines. In a networked deployment, the machine may operate in the capacity of a server or a client machine in server-client network environment, or as a peer machine in a peer-to-peer (or distributed) network environment. The machine may be a server computer, a client computer, a personal computer (PC), a tablet PC, a set-top box (STB), a Personal Digital Assistant (PDA), a cellular telephone, a web appliance, a network router, switch or bridge, or any machine capable of executing a set of instructions (sequential or otherwise) that specify actions to be taken by that machine. Further, while only a single machine is illustrated, the term “machine” shall also be taken to include any collection of machines that individually or jointly execute a set (or multiple sets) of instructions to perform any one or more of the methodologies discussed herein.

[0183] The example computer system **2900** includes a processor **2902** (e.g., a central processing unit (CPU) a graphics processing unit (GPU) or both), a main memory **2904** and a static memory **2906**, which communicate with each other via a bus **2908**. The computer system **2900** may further include a video display unit **2910** (e.g., a liquid crystal display (LCD) or a cathode ray tube (CRT)). The computer system **2900** also includes an alphanumeric input device **2912** (e.g., a keyboard), a cursor control device **2914** (e.g., a mouse), a drive unit **2916**, a signal generation device **2918** (e.g., a speaker) and a network interface device **2920**.

[0184] The drive unit **2916** includes a machine-readable medium **2922** on which is stored one or more sets of instructions (e.g., software **2924**) embodying any one or more of the methodologies or functions described herein. The software **2924** may also reside, completely or at least partially, within the main memory **2904** and/or within the processor **2902** during execution thereof by the computer system **2900**, the main memory **2904** and the processor **2902** also constituting machine-readable media.

[0185] The software **2924** may further be transmitted or received over a network **2926** via the network interface device **2920**.

[0186] While the machine-readable medium **2922** is shown in an example embodiment to be a single medium, the term

“machine-readable medium” should be taken to include a single medium or multiple media (e.g., a centralized or distributed database, and/or associated caches and servers) that store the one or more sets of instructions. The term “machine-readable medium” shall also be taken to include any medium that is capable of storing, encoding or carrying a set of instructions for execution by the machine and that cause the machine to perform any one or more of the methodologies of the present invention. The term “machine-readable medium” shall accordingly be taken to include, but not be limited to, solid-state memories, optical and magnetic media, and carrier wave signals.

[0187] Certain systems, apparatus, applications or processes are described herein as including a number of modules or mechanisms. A module or a mechanism may be a unit of distinct functionality that can provide information to, and receive information from, other modules. Accordingly, the described modules may be regarded as being communicatively coupled. Modules may also initiate communication with input or output devices, and can operate on a resource (e.g., a collection of information). The modules be implemented as hardware circuitry, optical components, single or multi-processor circuits, memory circuits, software program modules and objects, firmware, and combinations thereof, as appropriate for particular implementations of various embodiments.

[0188] Thus, methods and systems for social network analysis have been described. Although the present invention has been described with reference to specific example embodiments, it will be evident that various modifications and changes may be made to these embodiments without departing from the broader spirit and scope of the invention. Accordingly, the specification and drawings are to be regarded in an illustrative rather than a restrictive sense.

[0189] The Abstract of the Disclosure is provided to comply with 37 C.F.R. §1.72(b), requiring an abstract that will allow the reader to quickly ascertain the nature of the technical disclosure. It is submitted with the understanding that it will not be used to interpret or limit the scope or meaning of the claims. In addition, in the foregoing Detailed Description, it can be seen that various features are grouped together in a single embodiment for the purpose of streamlining the disclosure. This method of disclosure is not to be interpreted as reflecting an intention that the claimed embodiments require more features than are expressly recited in each claim. Rather, as the following claims reflect, inventive subject matter lies in less than all features of a single disclosed embodiment. Thus the following claims are hereby incorporated into the Detailed Description, with each claim standing on its own as a separate embodiment.

What is claimed is:

1. A method comprising:

accessing user interaction data of a time period for a plurality of users in a social network;
performing network analysis on the user interaction data;
generating a necktie-shaped graph from the user interaction data in accordance with the performing of the network analysis; and
utilizing the necktie-shaped graph for analysis of the social network.

2. The method of claim **1**, further comprising:

accessing reputation information associated with the plurality of users; and

applying a texture to the necktie-shaped graph in accordance with the reputation information.

3. The method of claim **1**, further comprising:

accessing interaction frequency data associated with the plurality of users; and

applying a texture to the necktie-shaped graph in accordance with the interaction frequency data.

4. The method of claim **1**, further comprising:

accessing transactional financial data associated with the plurality of users; and

applying a texture to the necktie-shaped graph in accordance with the transactional financial data.

5. The method of claim **1**, wherein the generating comprises:

generating a strongly connected component of the necktie-shaped graph in accordance with the performing of the network analysis;

generating an in-component of the necktie-shaped graph in accordance with the performing of the network analysis; and

generating an out-component of the necktie-shaped graph in accordance with the performing of the network analysis; and

using a tube to connect the in-component to the out-component,

wherein the in-component of the necktie-shaped graph is smaller than the out-component of the necktie-shaped graph.

6. The method of claim **5**, further comprising:

generating one or more tendrils in accordance with the performing of the network analysis, a particular tendril of the one or more tendrils connected to the in-component or the out-component.

7. The method of claim **5**, further comprising:

generating a disconnected part in accordance with the performing of the network analysis, the disconnected part being disconnected from the strongly connect component, the in-component, and the out-component in the necktie-shaped graph.

8. The method of claim **1**, wherein the utilizing comprises: analyzing the necktie-shaped graph;

making a decision regarding the social network in accordance with the analyzing of the necktie-shaped graph; and

altering an aspect of the social network in accordance with the making of the decision.

9. The method of claim **1**, wherein the utilizing comprises: providing the necktie-shaped graph for presentation.

10. The method of claim **1**, wherein the utilizing comprises:

accessing additional user interaction data associated with the social network during a different time period;

performing the network analysis on the additional user interaction data;

generating an additional necktie-shaped graph from the additional user interaction data in accordance with the performing of the network analysis; and

using the necktie-shaped graph and the additional necktie-shaped graph for analysis of the social network.

11. The method of claim **10**, wherein the using comprises: providing a difference between the necktie-shaped graph and the additional necktie-shaped graph for presentation.

12. The method of claim **1**, wherein the user interaction data is associated with a single transaction category.

13. A method comprising:

accessing user interaction data associated for a plurality of users for a time period in a social network;

performing network analysis on the user interaction data;

selecting a plurality of example users within the social network, each of the example users being associated with reputation information;

generating a motif for the plurality of example users for the time period in accordance with the performing of the network analysis, a node of the motif being associated with a particular example user of the example users, the motif defining an expected relationship between the plurality of example users in the social network;

distinguishing the node of the plurality of example users in accordance with the reputation information of a respective example user; and

utilizing the motif with a plurality of distinguished nodes for analysis of the social network.

14. The method of claim **13**, wherein the utilizing comprises:

providing the motif with the plurality of distinguished nodes for presentation.

15. The method of claim **13**, wherein the utilizing comprises:

analyzing a template including the motif and a plurality of additional motifs; and

making a decision regarding the social network in accordance with the analyzing of the template.

16. The method of claim **13**, further comprising:

accessing interaction frequency data associated with the plurality of users; and

applying a texture to at least one connecting line of the motif in accordance with the interaction frequency data.

17. The method of claim **13**, further comprising:

accessing transactional financial data associated with the plurality of users; and

applying a texture to at least one connecting line of the motif in accordance with the transactional financial data.

18. The method of claim **13**, wherein the distinguishing comprises:

colorizing the node of the plurality of example users in accordance with the reputation information.

19. The method of claim **13**, wherein the social network is a social commerce network.

20. A machine-readable medium comprising instructions, which when implemented by one or more processors perform the following operations:

access user interaction data of a time period for a plurality of users in a social network;

perform network analysis on the user interaction data;

generate a necktie-shaped graph from the user interaction data in accordance with the performing of the network analysis; and

utilize the necktie-shaped graph for analysis of the social network.

21. The machine-readable medium of claim **20**, wherein the one or more operations to generate the necktie-shaped graph include:

generate a strongly connected component of the necktie-shaped graph in accordance with the performing of the network analysis;

generate an in-component of the necktie-shaped graph in accordance with the performing of the network analysis; and

generate an out-component of the necktie-shaped graph in accordance with the performing of the network analysis; and

use a tube to connect the in-component to the out-component;

wherein the in-component of the necktie-shaped graph is smaller than the out-component of the necktie-shaped graph.

22. A machine-readable medium comprising instructions, which when implemented by one or more processors perform the following operations:

access user interaction data associated for a plurality of users for a time period in a social network;

perform network analysis on the user interaction data;

select a plurality of example users within the social network, each of the example users being associated with reputation information;

generate a motif for the plurality of example users for the time period in accordance with the performing of the network analysis, a node of the motif being associated with a particular example user of the example users, the motif defining an expected relationship between the plurality of example users in the social network;

distinguish the node of the plurality of example users in accordance with the reputation information of a respective example user; and

utilize the motif with a plurality of distinguished nodes for analysis of the social network.

23. The machine-readable medium of claim **22** further comprising instructions, which when implemented by one or more processors perform the following operations:

access interaction frequency data associated with the plurality of users; and

apply a texture to at least one connecting line of the motif in accordance with the interaction frequency data.

24. A system comprising:

a transaction relationship data access module to access user interaction data of a time period for a plurality of users in a social network;

a network analysis performance module to perform network analysis on the user interaction data accessed by the transaction relationship data access module;

a graph generation module to generate a necktie-shaped graph from the user interaction data in accordance with the performing of the network analysis by the network analysis performance module; and

a graph provider module to provide the necktie-shaped graph generated by the graph generation module for presentation.

25. The system of claim **24**, further comprising:

a reputation information access module to access reputation information associated with the plurality of users; and

a texture application module to apply a texture to the necktie-shaped graph generated by the graph generation module in accordance with the reputation information.