

(No Model.)

2 Sheets—Sheet 1.

F. H. PECK.
BICYCLE.

No. 523,942.

Patented July 31, 1894.

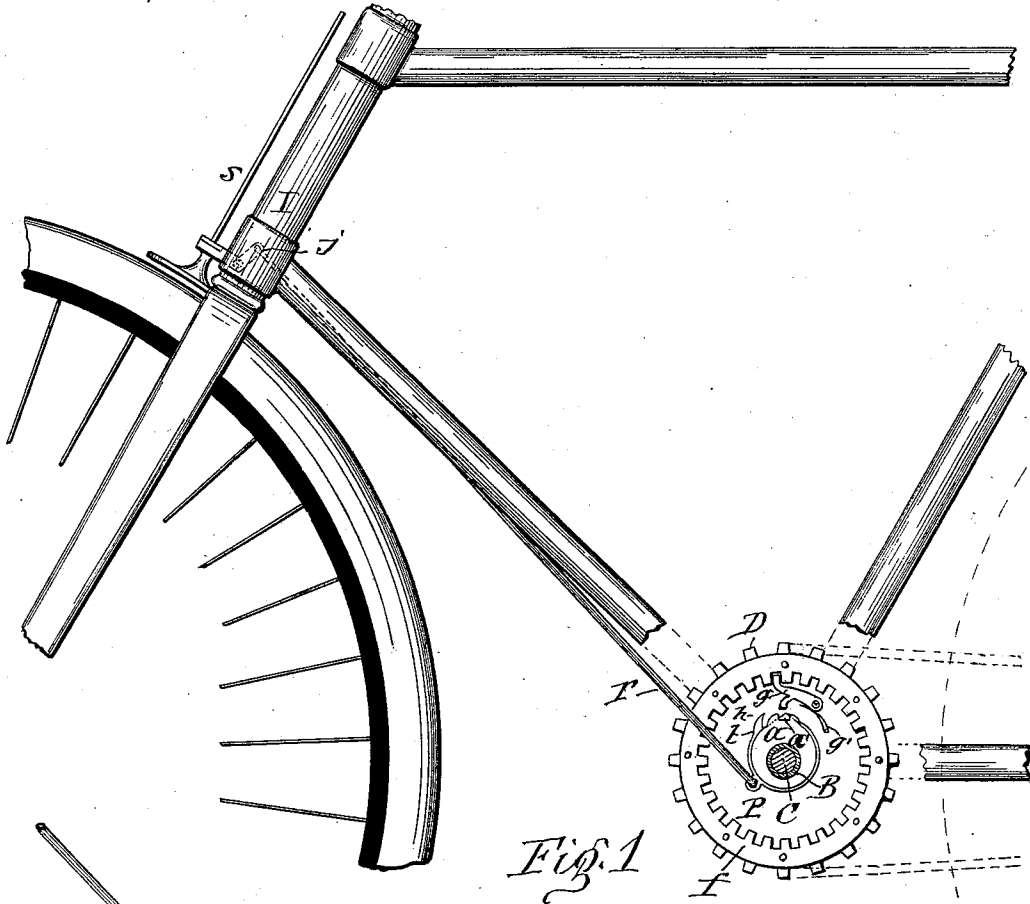

Fig. 1

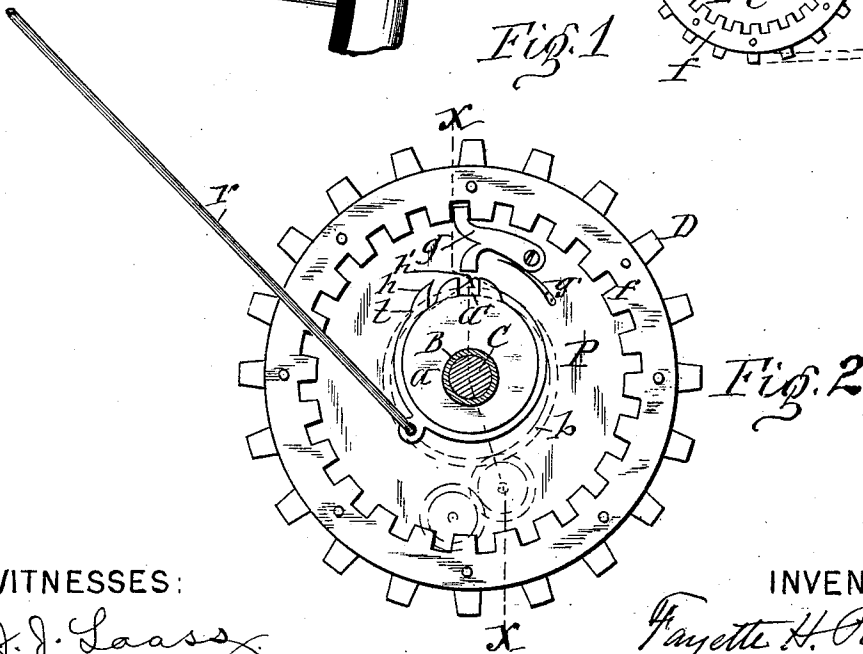

Fig. 2

WITNESSES:

J. J. Laass
C. L. Bondixon

INVENTOR:

Fayette H. Peck
By C. Laass
his ATTORNEY

(No Model.)

2 Sheets—Sheet 2.

F. H. PECK.
BICYCLE.

No. 523,942.

Patented July 31, 1894.

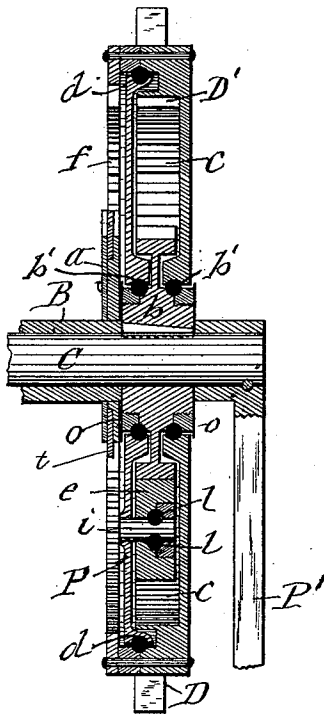

Fig. 3

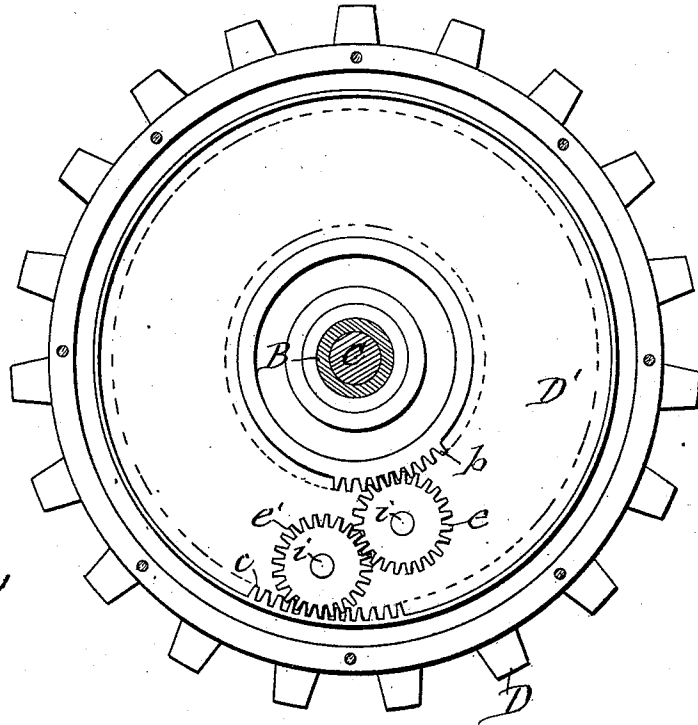

Fig. 4

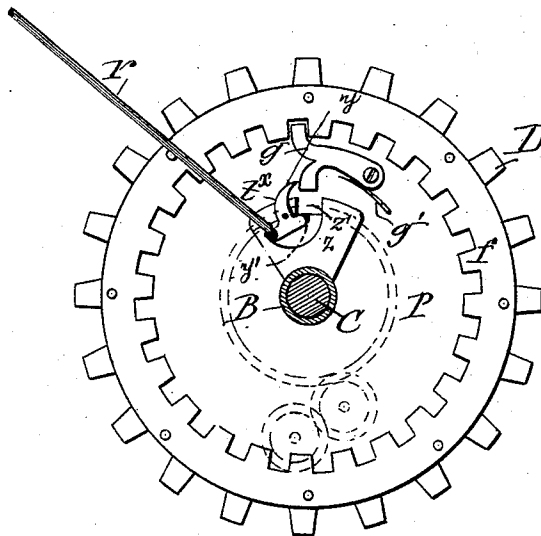

Fig. 5

WITNESSES:

J. J. Laasy
C. L. Bendixon

INVENTOR:

Fayette H. Peck
By E. Laasy
his ATTORNEY

UNITED STATES PATENT OFFICE.

FAYETTE H. PECK, OF CLINTON, NEW YORK.

BICYCLE.

SPECIFICATION forming part of Letters Patent No. 523,942, dated July 31, 1894.

Application filed April 14, 1893. Serial No. 470,322. (No model.)

To all whom it may concern:

Be it known that I, FAYETTE H. PECK, of Clinton, in the county of Oneida, in the State of New York, have invented new and useful
5 Improvements in Bicycles, of which the following, taken in connection with the accompanying drawings, is a full, clear, and exact description.

This invention relates to devices employed
10 for varying the transmission of power from the driving shaft to the propelling wheel so that either rapid motion may be imparted to the wheel with moderate power applied to the shaft while traveling over a smooth level road,
15 or slow motion of the wheel with increased power onto the shaft may be obtained when traveling over an ascending grade.

The object of my present invention is to accomplish the aforesaid results by more compact and more efficient means. And to that
20 end the invention consists in the improved construction and combination of parts hereinafter fully described and specifically set forth in the claims.

In the annexed drawings Figure 1 is, an inner side-view of my improved power transmitter in connection with the brake-rod of the bicycle. Fig. 2 is an enlarged view of the same. Fig. 3 is an enlarged transverse section on line x, x , in Fig. 2. Fig. 4 is a view
30 of the interior of the sprocket wheel, and Fig. 5 is an inner side view of a modification of my invention.

Similar letters of reference indicate corresponding parts.

Referring to Figs. 1, 2, 3 and 4 B— denotes the hanger in which is journaled the driving axle—C— which latter has affixed to its ends the usual cranks—P'. To one end of said
40 hanger is rigidly attached the catch-plate— a — which is provided with the notch— a' — in its periphery. Adjacent to said catch-plate is the driving pinion— b — fastened to the axle. The hub of this pinion is sufficiently
45 elongated to be provided with the ball bearings— $b'-b'$ — at opposite sides of the web of the pinion as shown in Fig. 3 of the drawings. Upon the outer of said ball bearings is mounted the sprocket-wheel—D— which is
50 formed with an annular cavity—D'— on its inner side and formed with the rack— c — on

the interior of the rim of said wheel. Upon the other of the aforesaid ball-bearings is mounted the annular plate—P— the periphery of which is fitted to the interior of the rim
55 of the wheel—D— by ball-bearings— d . The aforesaid ball-bearings not only relieve the sprocket wheel from friction but also serve to sustain said wheel in its requisite plane at right angles to the axle, and by mounting the
60 sprocket-wheel—D— and plate—P— on the hub of the pinion— b —, the said parts are arranged in a most compact and very neat manner.

To the plate—P— are fastened gudgeons
65 — $i-i$ — on which are mounted the intermediate pinions— $e-e'$ — which mesh with each other and with the pinion— b — and rack— c — as shown in Fig. 4 of the drawings. The said intermediate pinions I provide with
70 ball-bearings— $l-l$ — on the gudgeons to obviate friction.

To the inner edge of the rim of the sprocket-wheel is fastened an inwardly toothed annular ratchet plate— f —, and to the plate—P—
75 is pivoted the duplex pawl— g —, one end of which is adapted to engage and release the notch— a' — of the catch plate— a —, and the opposite end is adapted to engage and release the ratchet-plate— f —. A spring— g' — holds
80 said pawl normally in engagement with said ratchet-plate, and when thus engaged it is released from the notch— a' . To the catch plate is connected a suitable tripper— t — which may consist of a disk pivoted to the
85 catch-plate and formed with the tooth— h — and cam— h' — on its periphery as shown in Fig. 2 of the drawings. The said tripper is connected by a rod— r — to one of the arms of a bell-crank lever— j — pivoted to the head
90 —I— of the frame. The other arm of the lever— j — is connected to a rod— s — which may be the brake-rod moved longitudinally by a suitable lever connected to the upper end of the head—I— not necessary to be
95 shown.

Fig. 5 of the drawings shows locking devices differing somewhat in construction from those shown in the other figures, but which operate in substantially the same manner.
100 The part z forming the catch-plate is shown as a segment of a disk integral with the hanger

B, and provided with a notch z' in its edge, for the duplex pawl g , and the part t^x called the tripper consists of a small bar pivoted near its center to the catch plate near and upon one side of the notch, z' , and carrying a tooth y , to engage the duplex pawl. The cam y' for assisting the removal of the said pawl from the notch when the tripper is operated to release the pawl, g , from the catch-plate, is formed by one end of the said tripper-bar, the other end of the bar is connected to the rod r .

All of the ball-bearings of the sprocket-wheel —D— and plates —P— are protected from dust by disks —o—o— of felt or other suitable material secured to the outer sides of the said wheel and plate.

Any matters shown or described herein, but not claimed, are not dedicated to the public, but are claimed in my application, Serial No. 483,028, filed August 12, 1893.

The operation of the described differentiating power-transmitter is as follows: The pawl — g — being held normally engaged with the ratchet-plate — f — locks the plate —P— on the ratchet-wheel, hence the power is transmitted from the driving pinion — b — directly to the sprocket-wheel and compels the same to revolve in unison with the said pinion. The sprocket-wheel is thus geared for high speed and in this condition the power-transmitter is maintained while the bicycle is propelled over a smooth level road. When ascending a grade, the rider of the bicycle applies pressure on the rod — s — and this turns, by means of the lever — j — and rod — r —, the tripper — t — so as to throw the tooth — h — in the path of the inner end of the duplex pawl — g —, which is thereby drawn out of engagement with the ratchet-plate — f — and made to engage the notch — a' — of the catch-plate — a —. This locks the plate —P— to the plate — a — and therefore holds said plate stationary. As soon as this is effected the intermediate pinions — e — e' — are caused to transmit the power from the driving pinion — b — to the rack — c — which is integral with the sprocket-wheel. The speed of the

latter is thus reduced and the power is greatly increased in its transmission. 50

When it is desired to change the gears for high-speed the rider reverses his operation on the rod — s — and thereby turns the tripper — t — back so as to cause the cam — h' — thereof to throw the pawl out of the notch — a' — and allow said pawl to spring into engagement with the ratchet-plate — f —. 55

Having described my invention, what I claim as new, and desire to secure by Letters Patent, is— 60

1. The combination, with the driving axle and hanger, of the pinion on the driving axle, the loosely mounted sprocket wheel provided with the rack, the plate movable independently of the aforesaid pinion and sprocket wheel, the pinions pivoted to said plate and engaging the pinion on the axle and the rack, the annular ratchet rigid on the sprocket-wheel, the catch-plate fastened to the hanger, the duplex pawl adapted to engage alternately the aforesaid ratchet and catch-plate, and the tripper for throwing the said pawl in engagement with the catch-plate, as set forth. 65

2. In combination with the axle —C—, hanger —B—, pinion — b —, loosely mounted sprocket-wheel —D— provided with the rack — c —, plate —P— revoluble on the hub of said pinion, pinions — e — e' — pivoted to said plate, and ratchet — f — fixed to the sprocket-wheel, the catch-plate — a — fastened to the hanger and provided with the notch — a' —, the duplex pawl — g — adapted to engage alternately said ratchet and notch of the catch-plate, a spring holding said pawl normally engaged with the ratchet, and the tripper — t — under control of the operator and provided with the tooth — h —, and cam — h' — for throwing the pawl in and out of engagement with the notch of the catch-plate, as set forth. 75 80 85 90

In testimony whereof I have hereunto signed my name this 29th day of March, 1893.
FAYETTE H. PECK. [L. S.]

Witnesses:

H. M. SEAMANS,
J. J. LAASS.