



(12) **EUROPEAN PATENT APPLICATION**

(43) Date of publication:
17.01.2007 Bulletin 2007/03

(51) Int Cl.:
H01R 4/24 (2006.01)

(21) Application number: **05022336.1**

(22) Date of filing: **13.10.2005**

(84) Designated Contracting States:
AT BE BG CH CY CZ DE DK EE ES FI FR GB GR HU IE IS IT LI LT LU LV MC NL PL PT RO SE SI SK TR
 Designated Extension States:
AL BA HR MK YU

(72) Inventors:
 • **Batet Torras, Jordi**
08206 Sabadell (Barcelona) (ES)
 • **Batet Santcliment, David**
08206 Sabadell (Barcelona) (ES)

(30) Priority: **12.07.2005 ES 200501692**

(74) Representative: **Maldonado Jordan, Julia**
Linares, 7
46018 Valencia (ES)

(71) Applicant: **SISTEL S.A.**
08206 Sabadell (ES)

(54) **Terminal box**

(57) This connection box consists of a cover (2) with facing openings (11) to route an electric cable bundle (3) and side openings (12) for the output of electric bypass cables (3), and a base (1) which has sockets (12) with slots (14) to house connectors (4), which have notches (41) delimited by cutting edges to cut the sheathing of

the cables (3) inserted inside, ensuring the electric contact of the conductive cores of both cables (3) with the connector (4), and the electric interconnection of these cables (3) through the connector (4). The connectors (4) may have various geometric configurations, and the notches (41) may have the same or different widths.

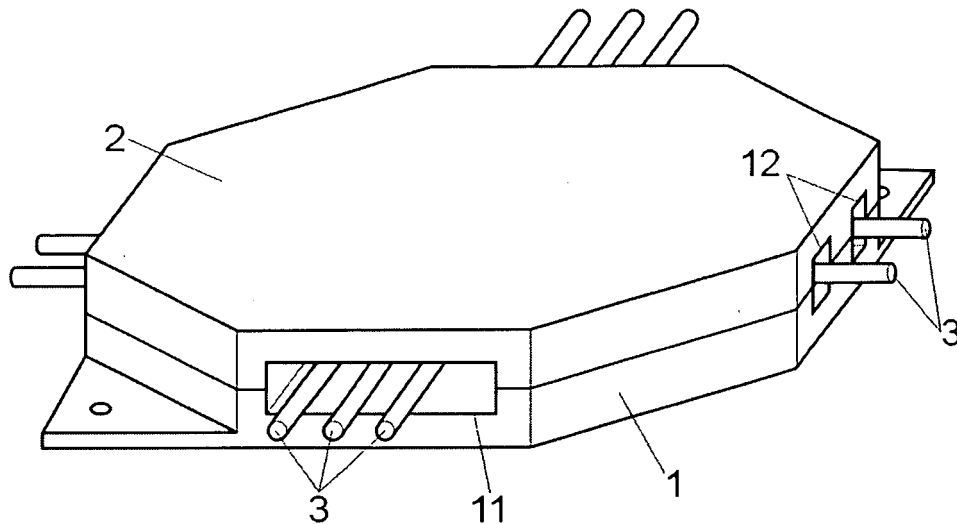

Fig. 1

Description

Purpose of the invention

[0001] This invention refers to a terminal box, of those used in various installations, to route and bypass cables provided with a core and insulation sheathing.

Background to the invention.

[0002] At present there is a wide variety of terminal boxes to establish bypasses and connections between electrical cables of an installation. A typical case is the box used in the bypass of a multiple cable bundle, which consists of a box with an access cover. Splicing and bypassing is carried out inside the box, either manually or using more or less sophisticated splicing devices.

[0003] To place these boxes on the cable bundle, it usually has a set of cable outlets and inlets and outlets for the bypassing cables.

[0004] In these terminal boxes, the cables to be bypassed must be cut in order to splice them to the same line or to the corresponding bypasses, using terminal strips with bolted mechanical splices or similar.

[0005] These splicing terminal strips mean that the cable has to be stripped and a portion of the sheathing has to be removed leaving the conductor cable and the drive of the jackscrews bare. Apart from being particularly slow and laborious, this operation also involves the risk of faulty connections, owing to incorrect tightening of the terminal strip screws or connection elements.

Description of the invention

[0006] The connection box of this invention has special technical features that enable electrical cables to be bypassed in a quick, simple and safe manner, without using coupling screws or clamps on the cable or cables to be connected and without the need to strip the cables to be connected.

[0007] The connection box of the invention consists of a base or box containing one or more sockets with slots to house separate electrical connectors.

[0008] Each connector consists of an electrically conductive metal plate with at least one notch with cutting edges to tightly insert the cable or cables sideways. This notch has a smaller width than the external diameter of the cable and equal or slightly smaller than the diameter of the conductive core, so that when the cable is inserted in the aforementioned notch, the sheathing of the cables to be connected is cut and the core becomes in close contact.

[0009] As the connector is made of electrically conductive material, the conductive cores of all cables inserted in the same connector are directly interconnected.

[0010] To ensure that the cables remain closely fitted and fixed in the connectors, on the opposite side of the notches, the cover of the box has projecting parts, which

press the connected cables sideways, preventing them from coming out of the corresponding notches.

[0011] In the preferential manufacture, the connectors are flat and the notches of each connector are at two levels, in order to place the main cables in one of them and the bypass cables in the other. This means that the insertion position of the main cables and of the bypass cables can be distinguished reducing the risk of error in insertion.

[0012] The connectors can optionally consist of flat parts, folded in a "U", with the connection notches aligned and shaped in the respective sides of the "U" configuration.

[0013] These connectors are placed in the corresponding slots of the base of the box, with the notches facing the upper part of the box in order to easily insert the electric cables.

[0014] To help the operator with the connection, the terminal strip is placed between the inputs and outputs of the cables, in a transversal position, with the connectors in the same direction of these cables. The connection box may have connectors with notches of different widths so that cables with different diameters can be electrically connected in the same box.

[0015] The cover and the base may be joined using complementary press-on elements, threaded tightening elements or any other conventional fastening element, as this does not affect the essence of the invention.

Description of the figures.

[0016] To complement this description and for a better understanding of the characteristics of the invention, a set of illustrative drawings without limitation is herewith attached to the description, which show the following:

- Figure 1 shows a perspective view of the connection box, in position of use, with the cover attached to the base.
- Figure 2 shows a ground view of the base showing the flat connectors and several cables inserted in the slots of the connectors.
- Figure 3 is a detailed view of one of the flat connectors dismantled and opposite the corresponding insertion slot of the socket.
- Figure 4 is a detailed view of a manufacturing variation of the connector, in the shape of a "U".

Preferential manufacture of the invention

[0017] As can be observed in the figures, the box consists of a lower base (1) and a cover (2), which in the assembly position form openings (11), which are longitudinally facing each other for the inlet and outlet of conductor cables (3), and side openings (12) for the outlet of bypass conductor cables (3). At the bottom of the box (1) is a socket (13) with slots (14) to insert the electrical connectors (4).

[0018] In the example shown in figures 2 and 3, each electrical connector (4) consists of a flat, electrically conductive metal part, with two notches (41) with cutting edges to insert the cables (3) to be connected.

[0019] As shown in figure 3, the notches in the connector are placed at two different heights, with the upper notch (41) aligned with a castellated shape projecting part to route the main cable (3), and the lower notch (41) aligned with a housing to place the bypass cable (3).

[0020] The width of the notches (41) is smaller than the outer diameter of the cables (3) to be connected, so that when the cables (3) are inserted inside, the cutting edges cut the sheathing of the cables (3), make contact with the core, and therefore the connector (4) ensures the electrical interconnection of the main and bypass cables (3), inserted in the notches (41).

[0021] These connectors enable a cable (3) to be bypassed without the need to cut its core nor to strip or remove part of the sheathing, as the sheathing is cut by the cutting edges of the connector when the cable is inserted sideways in the notch of the connector.

[0022] The notch (41) is sufficiently deep to house at least one cable (3), although it has also been planned that two or more cables (3) can be inserted in the same notch (41) of the connector (4), so that they are electrically connected by contact of the corresponding cores with the connector (4).

[0023] In an alternative manufacture, shown in figure 4, the connectors (4) consist of flat parts, folded in a "U", with cutting-edged notches (41) on the sides, so that the cables (3) to be connected can be inserted sideways.

[0024] As can be observed in figure 2, there is a coupling (5) in the centre of the box (2), to retain the cable in the insertion position.

[0025] Having described the nature of the invention and an example of preferential manufacture, we would like to state that materials, shape, size and lay-out of elements can be modified, as long as this does not alter the essential characteristics of the invention, the claims to which are given below.

(4), and the electrical interconnection of these cables (3) through the connector (4).

2. A box, in accordance with claim 1, **characterised** because the connector (4) consists of a flat part with two notches (41), to place the cables (3) to be connected.
3. A box, in accordance with claim 1, **characterised** because the connector (4) consists of a flat part, folded into a "U", with aligned notches (41) on the sides.
4. A box, in accordance with any of the above claims, **characterised** because the notches of the same terminal strip (13) can be of different widths for the interconnection of electric cables (3) of different sections and diameters.

Claims

1. Connection box, of the type used in various installations, to route and bypass cables, provided with a core and sheathing. This box consists of a base or box (1) and a cover (2) with opposite openings (11) to route an electrical cable bundle (3), and optionally one or more side openings (12) for the outlet of bypass electric cables (3), **characterised** because the base (1) has at least one socket (13) with slots (14) to house the corresponding independent electrically conductive connectors (4); and because each connector (4) has at least one notch (41) delimited by cutting edges to cut the sheathing of the cables (3) inserted sideways inside, ensuring the electrical contact of the cores of both cables (3) with the connector

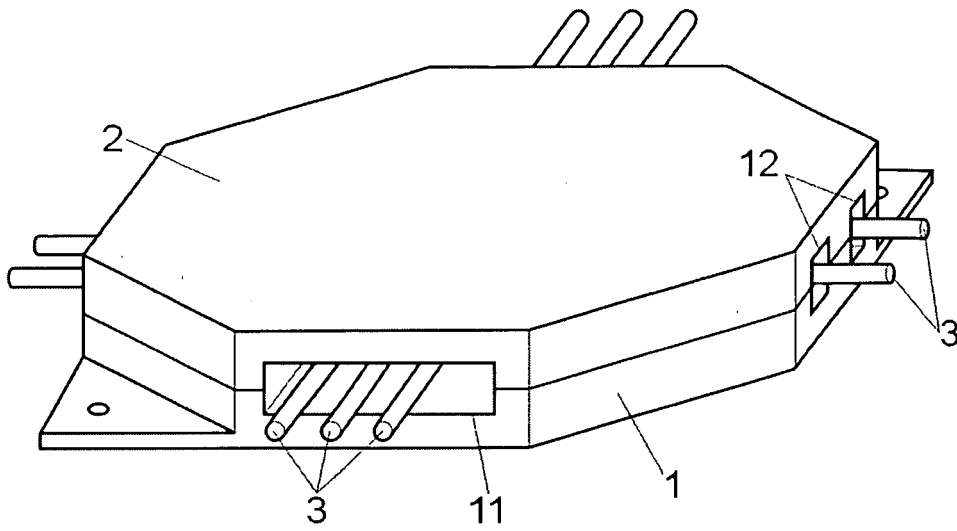

Fig. 1

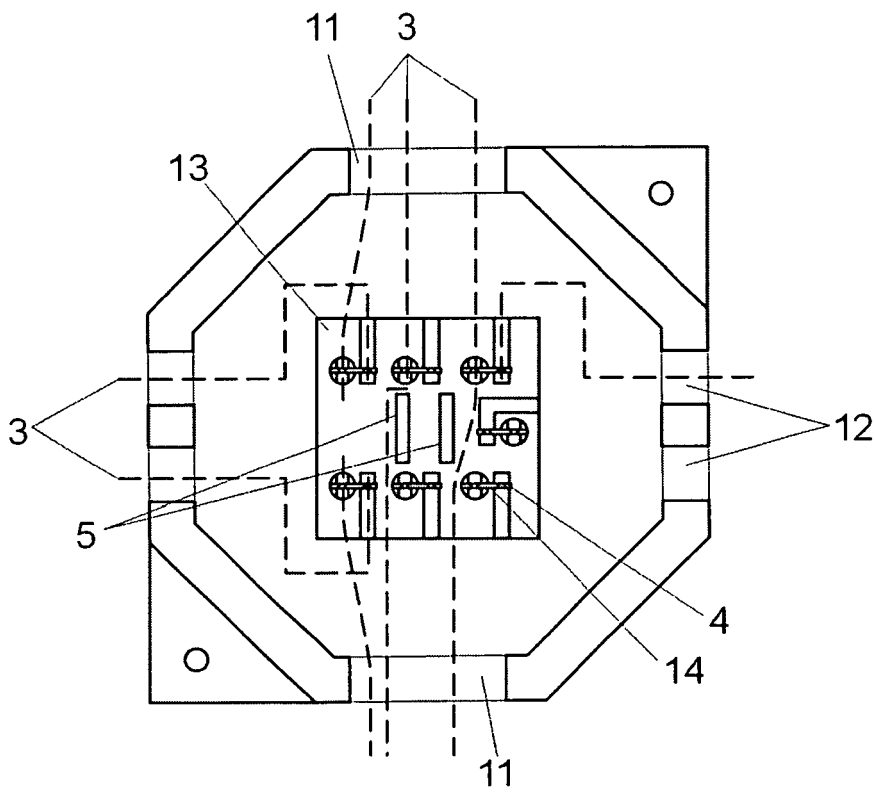

Fig. 2

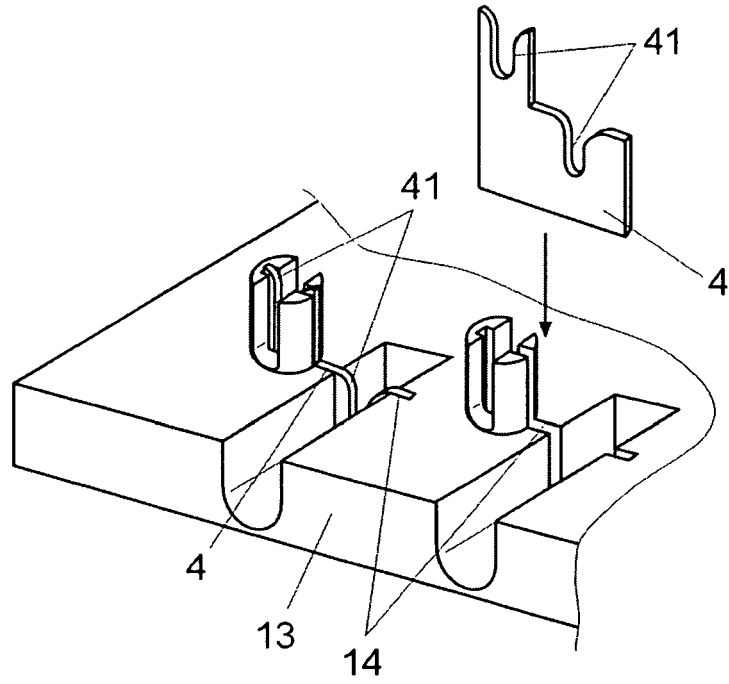

Fig. 3

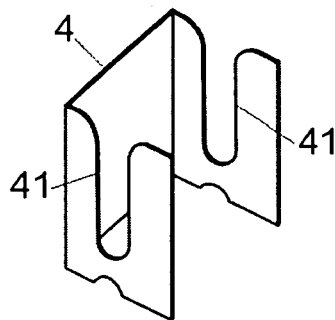

Fig. 4



DOCUMENTS CONSIDERED TO BE RELEVANT			
Category	Citation of document with indication, where appropriate, of relevant passages	Relevant to claim	CLASSIFICATION OF THE APPLICATION (IPC)
X	US 5 820 404 A (CHISHIMA MASAMITSU [JP] ET AL) 13 October 1998 (1998-10-13) * column 9, line 54 - column 19, line 15; figures 1-29 *	1-3	INV. H01R4/24
X	----- US 6 443 755 B1 (BEUKES CHRISTO ANDRE [ZA] ET AL) 3 September 2002 (2002-09-03) * column 2, line 50 - column 3, line 39; figures 1,2 *	1	
A	----- DE 101 59 754 A1 (SUMITOMO WIRING SYSTEMS [JP]) 12 September 2002 (2002-09-12) * abstract; figures 1-5 *	1	
A	----- US 5 199 899 A (ITTAH JEAN [FR]) 6 April 1993 (1993-04-06)		
A	----- US 4 778 405 A (STERKEN CORNELUS A H M [NL]) 18 October 1988 (1988-10-18) -----		
The present search report has been drawn up for all claims			TECHNICAL FIELDS SEARCHED (IPC)
			H01R
Place of search		Date of completion of the search	Examiner
The Hague		2 October 2006	Lommel, Armand
CATEGORY OF CITED DOCUMENTS		T : theory or principle underlying the invention E : earlier patent document, but published on, or after the filing date D : document cited in the application L : document cited for other reasons & : member of the same patent family, corresponding document	
X : particularly relevant if taken alone Y : particularly relevant if combined with another document of the same category A : technological background O : non-written disclosure P : intermediate document			

3
EPO FORM 1503 03.82 (P04C01)

**ANNEX TO THE EUROPEAN SEARCH REPORT
ON EUROPEAN PATENT APPLICATION NO.**

EP 05 02 2336

This annex lists the patent family members relating to the patent documents cited in the above-mentioned European search report. The members are as contained in the European Patent Office EDP file on The European Patent Office is in no way liable for these particulars which are merely given for the purpose of information.

02-10-2006

Patent document cited in search report		Publication date		Patent family member(s)	Publication date
US 5820404	A	13-10-1998	CN	1143842 A	26-02-1997
			DE	69601754 D1	22-04-1999
			DE	69601754 T2	02-12-1999
			DE	69626046 D1	06-03-2003
			DE	69626046 T2	04-09-2003
			DE	69627385 D1	15-05-2003
			DE	69627385 T2	12-02-2004
			EP	0753900 A1	15-01-1997

US 6443755	B1	03-09-2002	AU	754576 B2	21-11-2002
			AU	4592599 A	24-01-2000
			WO	0002288 A1	13-01-2000
			CA	2336391 A1	13-01-2000
			DE	19983343 T0	21-06-2001
			SE	520615 C2	29-07-2003
			SE	0004868 A	28-12-2000

DE 10159754	A1	12-09-2002	JP	2002184480 A	28-06-2002

US 5199899	A	06-04-1993	DE	69104584 D1	17-11-1994
			DE	69104584 T2	16-03-1995
			EP	0478400 A1	01-04-1992
			FR	2666933 A1	20-03-1992

US 4778405	A	18-10-1988	NL	8502512 A	01-05-1986
			SE	461754 B	19-03-1990
			SE	8504443 A	06-04-1986
