

H. W. WEAVER.  
 STEAM ENGINE.  
 APPLICATION FILED JAN. 19, 1909.

961,186.

Patented June 14, 1910.

3 SHEETS—SHEET 1.

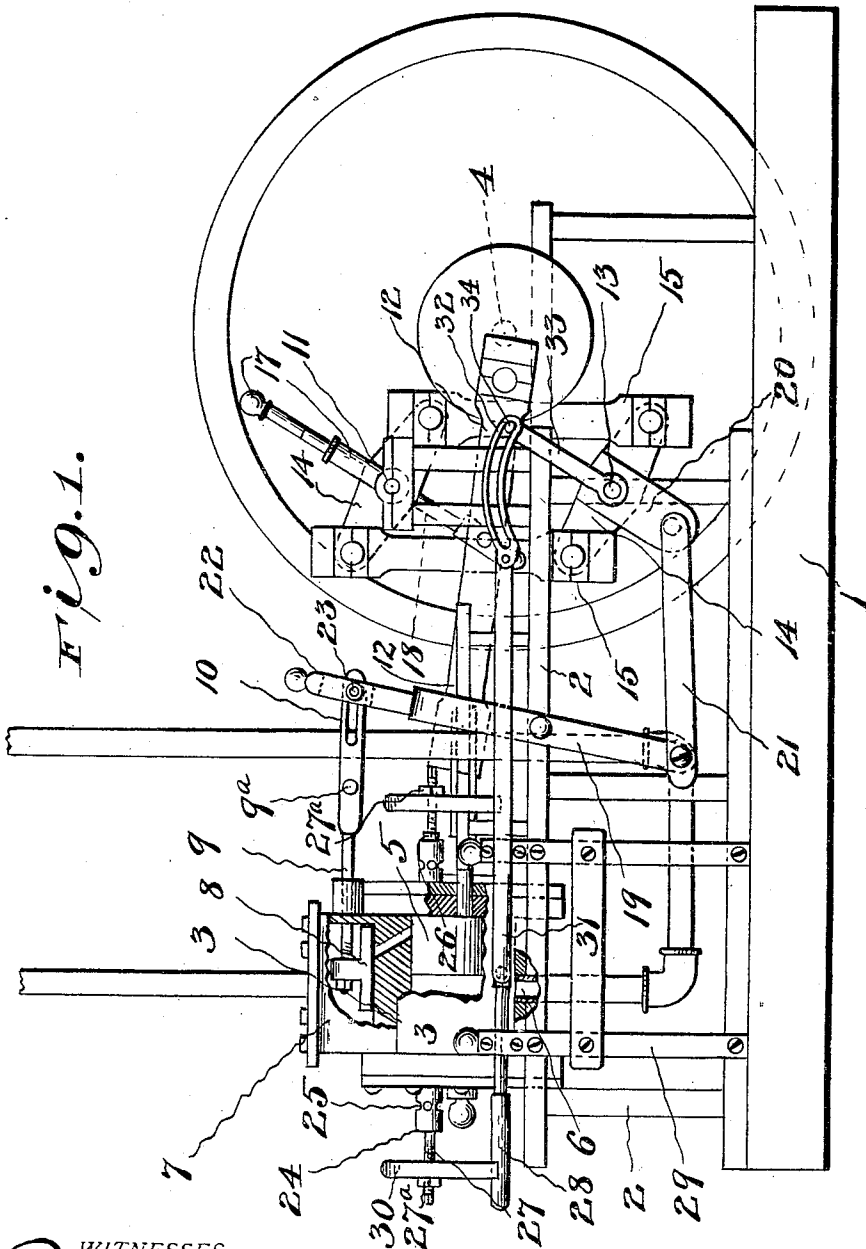

FIG. 1.

WITNESSES  
*James H. Greenwood*  
*W. H. Anderson, Jr.*

INVENTOR  
*H. W. Weaver*  
 by *L. A. Gourrier*  
 Attorney

H. W. WEAVER.  
STEAM ENGINE.  
APPLICATION FILED JAN. 19, 1909.

961,186.

Patented June 14, 1910.

3 SHEETS—SHEET 2.

Fig. 2.

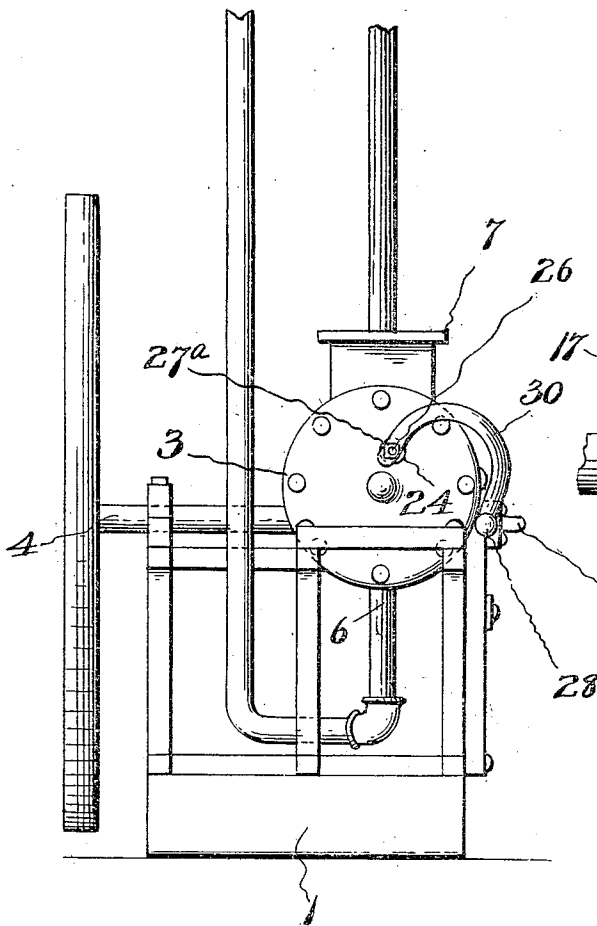
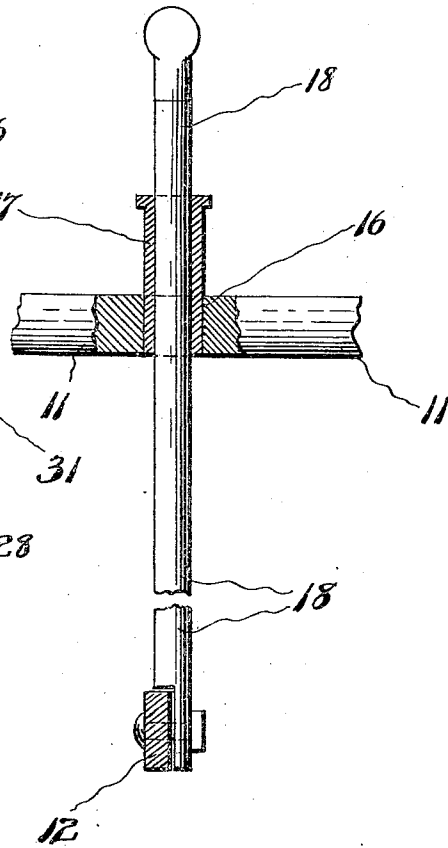

Fig. 4.



WITNESSES  
*James H. Blackwood*  
*Andrew J. [unclear]*

INVENTOR  
*Henry W. Weaver*  
by *J. A. Bowrick*  
Attorney



# UNITED STATES PATENT OFFICE.

HENRY W. WEAVER, OF HUTCHINSON, KANSAS.

## STEAM-ENGINE.

961,186.

Specification of Letters Patent. Patented June 14, 1910.

Application filed January 19, 1909. Serial No. 473,108.

To all whom it may concern:

Be it known that I, HENRY W. WEAVER, a citizen of the United States, residing at Hutchinson, in the county of Reno and State of Kansas, have invented certain new and useful Improvements in Steam-Engines, of which the following is a specification.

My invention relates to steam engines of the reciprocating piston type and has for one of its objects the provision of an improved valve gear for operating the reciprocating steam valve so as to secure a positive intermittent movement of the valve, and also provision of means by which the valve may be reversed when the engine is at a standstill so as to start it in a reverse direction from its former operation.

Another object of my invention is the provision of an improved construction of exhaust consisting of a valveless main exhaust located opposite the middle of the cylinder and constructing the piston a little less in length than one-half the length of the cylinder so that the entrance to the exhaust is opened at the end of the forward stroke of the piston to release the steam pressure.

My invention also includes a secondary exhaust at each end of the cylinder to exhaust the steam ahead of the piston after it has moved far enough to close the main exhaust in the middle of the cylinder. These secondary exhausts are provided with valves operated by the engine so that the valve at the end of the cylinder containing the expanded steam is opened at the end of the stroke, remains open to exhaust the steam ahead of the piston during its return and is closed just before the live steam is admitted for the next stroke of the engine.

The construction and operation of my improved engine will be described hereinafter and illustrated in the accompanying drawings in which—

Figure 1 is a side view of my improved engine, showing the cylinder in section, Fig. 2, an end view, Fig. 3, a plan view, Fig. 4, a detail view of the mechanism for actuating the valves from the pitman, and Fig. 5, a detail view of the secondary exhaust valves and their operating mechanism.

In the drawings similar reference characters indicate corresponding parts in all of the views.

1 indicates a suitable base on which is mounted the base frame 2 supporting the

cylinder 3, the crank shaft 4 and the other parts of the engine.

The piston 5 in cylinder 3 is slightly less than one-half the length of the cylinder and the exhaust 6 is located opposite the middle of the cylinder so that at the end of each stroke of the piston the exhaust port is exposed and remains open until the piston is driven back in its return stroke.

7 indicates the steam chest having the reciprocating steam valve 8 therein that is alternately actuated by the mechanism hereinafter described through the valve rod 9, said rod having a longitudinal slot 10 in its outer end.

11 indicates a rock shaft journaled above the pitman 12 driven by piston 5 and 13 another shaft journaled below the pitman, each of said shafts having arms 14 extending laterally therefrom and connected by links 15 for simultaneous operation. Shaft 11 is provided with a transverse opening 16 in which is secured a tubular guide 17 and pitman 12 has a rod 18 pivotally secured thereto that is mounted in said opening 16 and guide 17 so that as the pitman 12 reciprocates the shaft 11 is rocked and through links 15 and arms 14 shaft 13 is also rocked simultaneously with shaft 11.

19 indicates an inverted U-shaped frame pivotally secured to base frame 2 and having one of its arms extended and connected with arm 20 on shaft 13 by means of rod 21.

22 indicates a slotted head on the top of the inverted U-shaped frame 19 to receive the slotted end of valve rod 9, and 23 a pin secured in head 22 and engaging slot 10 in said valve rod.

It will be understood that as the piston moves back and forth the rod 18 on pitman 12 engaging the transverse opening 16 in shaft 11 rocks said shaft and through the medium of links 15 connecting the arms 14 extending therefrom rocks shaft 13. This rocking motion of shaft 13 is communicated to inverted U-shaped frame 19 by means of rod 21 connecting the free end of said frame and an arm 20 extending from shaft 13. The slot 10 admits of movement of the frame 19 through a portion of each stroke without moving the rod 9 and valve 8 so that the valve remains in position at one end of the steam chest 7 to admit steam behind the piston through substantially its whole stroke in one direction and is then moved

quickly to position at the other end of the steam chest to open the port leading to the other end of the cylinder and remains in that position through substantially the entire return stroke of the piston. It will be apparent that when the piston is moving in either direction it will cover the exhaust port 6 through the greater part of each stroke and that while the high pressure is relieved at the end of each stroke of the piston, as stated, still some steam will remain in the cylinder and, when the piston is making its return stroke, this steam will be compressed ahead of the piston, if no provision is made to relieve the pressure, and reduce the speed of the engine if it does not stop it altogether. To provide for this contingency blow-off valves are secured to the two ends of cylinder 3 consisting of tubes 24 having holes 25 therein and plungers 26 slidably mounted in said tubes and fitting them snugly enough to prevent the escape of steam when they cover holes 25. Plungers 26 are provided with threaded stems 27.

28 indicates a rod slidably mounted in bearing 29 secured to base frame 2 and 30 arms extending from said rod and having their free ends provided with eyes to engage stem 27 of the plungers.

27<sup>a</sup> indicates nuts engaging the threads on stems 27 on each side of arms 30 to adjust the plungers relative to said arms.

A rod 31 is pivotally secured to rod 28 and has a slotted link 32 pivotally secured to its free end.

33 indicates an arm secured to shaft 13 and 34 a pin on said arm that rides in the slot in the link 32. When shaft 13 is rocked as above described the pin 34 alternately engages the ends of the slotted link 32 and reciprocates it together with rods 28 and 31. As the rod 28 moves back and forth the arms 30 thereon move the valve plungers 26 at the two ends of the cylinder so that the one at the end toward which the piston is moving is opened while the valve at the other end is closed, this permitting the expanded steam ahead of the piston to exhaust and closing the other end of the cylinder to prevent escape of the live steam therein.

Should it be desired to reverse the engine while at rest it is accomplished by moving the valve rod 9, a handle 9<sup>a</sup> for this purpose being secured to the rod.

Having thus described my invention what I claim is—

1. In a reciprocating steam engine having a reciprocating valve actuated by a valve rod, and a pitman, a rock shaft, operative connections between said pitman and rock shaft, arms secured to said shaft, another rock shaft, arms secured to the last mentioned shaft, said arms being operatively connected, an arm secured to the last mentioned shaft, a rocking frame suitably

mounted and operatively connected to the valve rod, and a rod connecting said arm and frame.

2. In a reciprocating steam engine having a reciprocating valve actuated by a valve rod, and a pitman, a rock shaft, a rod pivotally secured to the pitman and slidably mounted on the rock shaft, arms secured to said shaft, another rock shaft suitably journaled, arms secured to the last mentioned shaft, said arms being operatively connected, an arm secured to the last mentioned shaft, and operative connections between said arm and valve rod.

3. In a reciprocating steam engine having a reciprocating valve actuated by a valve rod having a longitudinal slot therein, and a pitman, a rock shaft, a tubular guide secured to said shaft, a rod pivotally secured to the pitman and slidably mounted in said guide, arms secured to said shaft, another rock shaft suitably journaled, arms secured to the last mentioned shaft, said arms being operatively connected, an arm secured to the last described shaft, a rocking frame suitably mounted and secured to the valve rod through the slot therein, and a rod pivotally secured to the last mentioned arm and to said frame.

4. In a steam engine, a cylinder, the main exhaust port located opposite the middle of the cylinder, a reciprocating piston in the cylinder slightly less than one half the length of the cylinder, blow-off valves in the ends of the cylinder having sliding valve plungers, a rod slidably mounted, arms secured to said rod and to the plungers, a rod pivotally secured to said sliding rod, a rock shaft suitably journaled and operatively connected to the engine, and operative connections between said rock shaft and the pivoted rod aforesaid.

5. In a steam engine, a cylinder, the main exhaust port located opposite the middle of the cylinder, a reciprocating piston in the cylinder slightly less than one-half the length of the cylinder, blow-off valves in the end of the cylinder having sliding valve plungers, a rod slidably mounted, arms secured to said rod and to the plungers, a rod pivotally secured to said sliding rod, a slotted link secured to said pivoted rod, a rock shaft suitably journaled and operatively connected to the engine, an arm secured to said rock shaft, and a pin secured to said arm and riding in the slotted link aforesaid.

6. In a steam engine, a cylinder, the main exhaust port located opposite the middle of the cylinder, a reciprocating piston in the cylinder slightly less than one-half the length of the cylinder, blow-off exhaust ports in the ends of the cylinder, tubes having perforations secured in said blow-off ports, plungers slidably mounted in said tubes and covering said perforations at times, a rod

slidably mounted, arms connecting said rod and plungers, and means operated by the engine to actuate said rod.

7. In a steam engine, a cylinder, the main  
 5 exhaust port located opposite the middle of  
 the cylinder, a reciprocating piston in the  
 cylinder slightly less than one-half the  
 length of the cylinder, blow-off exhaust ports  
 in the ends of the cylinder, tubes having per-  
 10 forations secured in said blow-off ports,  
 plungers slidably mounted in said tubes and  
 covering said perforations at times, a rod  
 slidably mounted, arms connecting said rod  
 and plungers, a rod pivotally secured to said  
 15 sliding rod, a rock shaft suitably journaled  
 and operatively connected to the engine, and  
 operative connections between said rock  
 shaft and the pivoted rod aforesaid.

8. In a steam engine, a cylinder, the main  
 20 exhaust port located opposite the middle of  
 the cylinder, a reciprocating piston in the

cylinder slightly less than one-half the  
 length of the cylinder, blow-off exhaust ports  
 in the ends of the cylinder, tubes having per-  
 forations secured in said blow-off ports, 25  
 plungers slidably mounted in said tubes and  
 covering said perforations at times, a rod  
 slidably mounted, arms connecting said rod  
 and plungers, a rod pivotally secured to said  
 sliding rod, a slotted link secured to said 30  
 pivoted rod, a rock shaft suitably journaled  
 and operatively connected to the engine, an  
 arm secured to said rock shaft, and a pin se-  
 cured to said arm and riding in the slotted  
 link aforesaid.

In testimony whereof I hereto affix my 35  
 signature in the presence of two witnesses.

HENRY W. WEAVER.

Witnesses:

I. I. SHAPER,  
 THOMAS Q. MOORE.