

(No Model.)

C. F. DOEBLER.  
KNOB ATTACHMENT.

No. 565,108.

Patented Aug. 4, 1896.

Fig. 1.

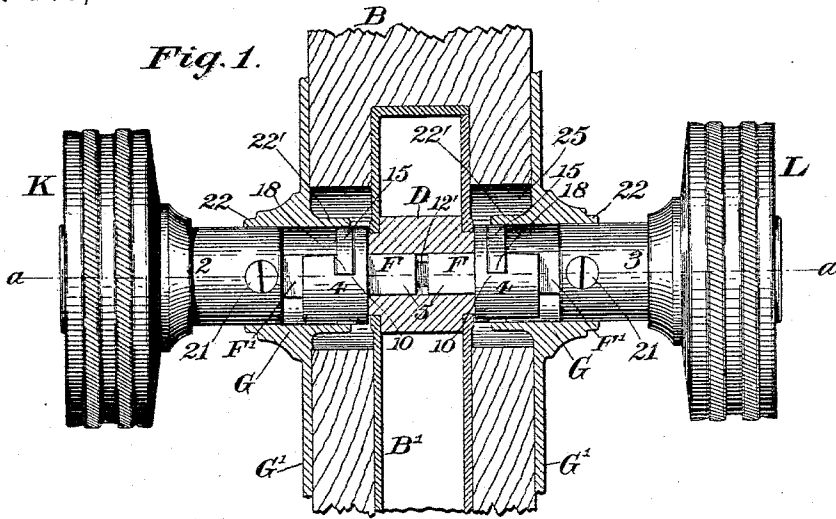

Fig. 2.

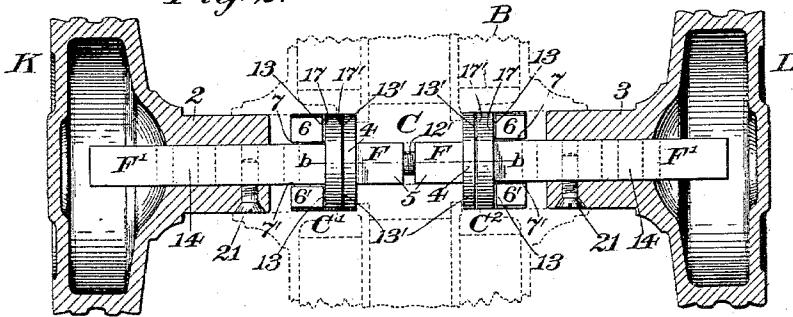

Fig. 5.

Fig. 6.

Fig. 3.

Fig. 11.

Fig. 12.

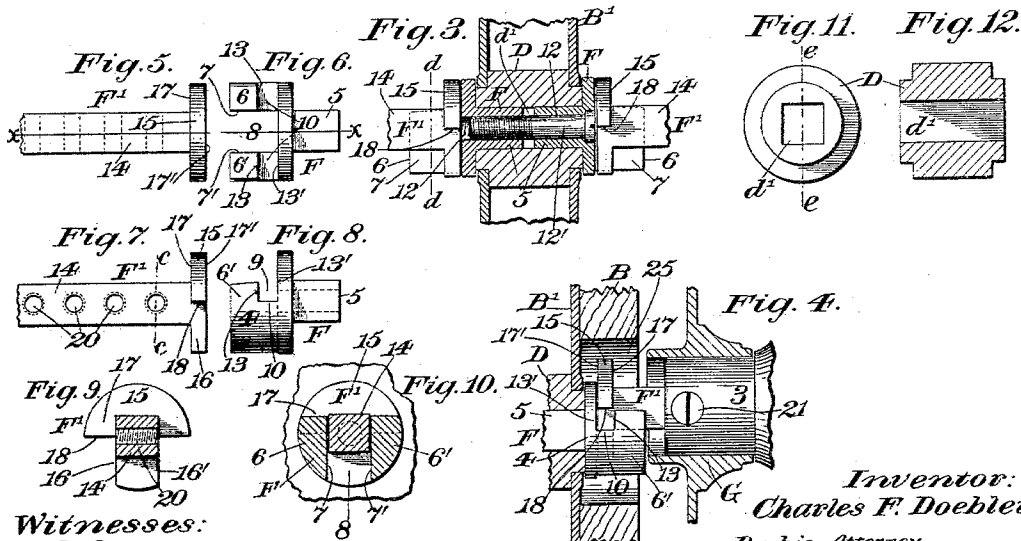

Fig. 7.

Fig. 8.

Fig. 4.

Fig. 9.

Fig. 10.

Witnesses:  
J. L. Edwards Jr.  
Fred. J. Dole.

Inventor:  
Charles F. Doebler.  
By his Attorney,

J. H. Richards.

# UNITED STATES PATENT OFFICE.

CHARLES F. DOEBLER, OF HARTFORD, CONNECTICUT.

## KNOB ATTACHMENT.

SPECIFICATION forming part of Letters Patent No. 565,108, dated August 4, 1896.

Application filed February 12, 1896. Serial No. 578,981. (No model.)

*To all whom it may concern:*

Be it known that I, CHARLES F. DOEBLER, a citizen of the United States, residing at Hartford, in the county of Hartford and State of Connecticut, have invented certain new and useful Improvements in Knob Attachments, of which the following is a specification.

This invention relates to knob attachments of that class in which the knobs are operatively connected with the latch-actuating hub by couplings or clutch devices, and which knob attachments are commonly known as "screwless" knob attachments.

One object of my present invention is to furnish an improved knob attachment of the class specified comprehending means whereby the knobs thereof may be quickly and operatively connected with the latch-actuating hub and locked as against movement longitudinally of their axes and as against rotative movement relatively to said hub, and also whereby said hubs may be relatively adjusted longitudinally of their axes of rotation to facilitate the application of the knob attachment to doors of different thicknesses, and whereby said knobs may be quickly disconnected from the latch-actuating hub by movements of said knobs laterally of said axes.

Another object of my present invention is to furnish a knob attachment comprehending two knobs, a duplex connector between and adjustably connecting said knobs, and comprising two substantially independent and interchangeable coupling devices normally connected together and to the latch-actuating hub of the door, and each coupling device embodying two laterally-separable normally-interlocked members, one member of which is adjustably secured to the knob.

Another object of my present invention is to furnish a knob attachment having a duplex knob-connector of a construction and organization adaptable for practical use with axially-recessed door-knobs of any ordinary construction, and which may be applied to said knob without requiring any changes to be made therein.

In the drawings accompanying and forming part of this specification, Figure 1 is a side view, partly in section, of a knob attach-

ment embodying my present invention, said figure showing in section a portion of a door and door-lock with the knob attachment applied thereto. Fig. 2 is a longitudinal section of the knob attachment, taken in dotted line *a a*, Fig. 1, certain parts being shown in dotted lines. Fig. 3 is a longitudinal section of a portion of the knob attachment and door-lock, taken in dotted line *b b*, Fig. 2. Fig. 4 is a view similar to Fig. 1 of a portion of the knob attachment and door-lock, said figure illustrating the manner in which the two coupling members of the coupling device for one door-knob may be disengaged from another. Fig. 5 is a plan view of a portion of the outer coupling member of one of the coupling devices of the duplex connector. Fig. 6 is a plan view of one of the inner coupling members of said duplex connector. Fig. 7 is a side view of one of the outer coupling members of the duplex connector, drawn in projection with Fig. 5. Fig. 8 is a side view of one of the inner coupling members, drawn in projection with Fig. 6. Fig. 9 is a cross-sectional view of one of the outer coupling members, taken in dotted line *c c*, Fig. 7, and looking toward the right hand in said figure. Fig. 10 is a cross-sectional view of a portion of the knob attachment, taken in dotted line *d d*, Fig. 3, and looking toward the right hand in said figure. Fig. 11 is an end view of the latch-actuating hub; and Fig. 12 is a longitudinal sectional view of said hub, taken in dotted line *e e*, Fig. 11.

Similar characters represent like parts in all the figures of the drawings.

In the preferred embodiment of my invention herein shown and described the knob attachment comprises two knobs (designated by *K* and *L*, respectively) having axially-recessed stems for the reception of the spindles of the coupling members of a connector; a duplex connector (designated in a general way by *C*) operatively and adjustably connecting the two knobs and comprising two interchangeable coupling devices (designated by *C'* and *C''*, respectively) and each of which has two coupling members *F* and *F'*, which are normally interlocked against relative longitudinal and rotative movement and are relatively separable laterally of the plane of their axes of rotation, and a bearing *G*, circumfer-

entially engaging the two coupling members of each coupling device and normally locking said members against movement laterally of each other.

5 By the terms "laterally separable," "laterally shiftable," and "laterally movable," as may be hereinafter employed to define the relative engaging and disengaging movements of the two members of one or both of  
10 the coupling devices of the duplex hub-connector, are meant such movements of said members as have their planes crosswise of the longitudinal axis of said members, and for the purpose of preventing a possible misunderstanding as to what is meant by "longitudinal axis" or "axes" as applied to said  
15 members it is desired to state that the longitudinal axis is the axis of rotative working movement of said members, which axis is represented by line  $x-x$ , Figs. 5 and 6 of the  
20 drawings.

In Figs. 1, 2, 3, and 4, B represents a portion of an ordinary door having therein a lock-case B', furnished with the usual cam  
25 or hub D for actuating the mechanism of the lock, said hub having the usual cross-sectionally-angular central opening  $d'$  to receive the cross-sectionally-angular parts of the inner coupling members of the two coupling devices C' and C<sup>2</sup>.  
30

The knobs K and L, which may be of any usual or suitable construction, are shown having stems 2 and 3, each stem having a cross-sectionally-angular central opening or recess  
35 for the reception of the cross-sectionally-angular part of the outer coupling member of the coupling devices C' and C<sup>2</sup>, connected therewith.

Inasmuch as the two coupling devices of  
40 the duplex knob-connector C are shown of substantially duplicate construction and organization, certain duplicate details of said devices are, for convenience, designated in the drawings by similar characters, and a  
45 specific description of one of said coupling devices may, in so far as the construction thereof is concerned, apply to both coupling devices.

Each of the coupling devices C' and C<sup>2</sup>, in  
50 the preferred form thereof herein shown and described, consists of two normally-interlocked rigid coupling members F and F', respectively, one of which is normally fixed, as hereinafter more fully described, to the latch-actuating hub D and will for convenience be  
55 hereinafter termed the "inner" coupling member or "hub-engaging" member, and the other of which members is adjustably secured to the door-knob and will be hereinafter  
60 termed the "outer" coupling member or "knob-engaging" member.

For the purpose of providing an interlocking instrumentality between the two coupling  
65 members F and F' of each coupling device, which is adapted for holding said members against relative rotative movement and against relative movement longitudinally of

their axes, said members are shown having at their adjacent or interlocking ends locking  
70 portions or faces, as will be hereinafter more fully described, some of which are located in planes parallel to the plane of the axis of rotation of said members, and others of which  
75 are located in planes at right angles to said axis, whereby the interlocking of the two coupling members may be secured in crosswise directions, and also securing a strong  
80 close connection between said coupling members that will positively hold said members against accidental displacement during the working of the device.

Each inner coupling member F, in the form thereof herein shown, consists of a somewhat  
85 discous main body portion 4, having a diametrically-reduced cross-sectionally-rectangular central projection 5 on one end thereof, and having the opposite end bifurcated and furnished with two outwardly-projecting L-shaped locking arms or prongs 6 and 6', preferably formed integral therewith and located  
90 one at each side of the longitudinal axis of said coupling members and having plane parallel bearing-faces 7 and 7' at the inner adjacent sides thereof.

The coupling member F, with the locking-  
95 arms 6 and 6' thereon, may be cast to the form above described and as shown in the drawings, or the outer end of said member may be cross-sectionally cylindrical and the L-shaped locking-arms may be formed there-  
100 on by bifurcating this end of said member—that is, by forming a groove 8 in this end of said member intersecting the longitudinal axis thereof, and then forming a relatively shallow groove 9 in the periphery of said member  
105 crosswise of and communicating with the first-mentioned groove 8 and at some distance from this end face of said member, the inner wall of said groove 9 being made flush with the inner end wall of the groove 8, as will be  
110 readily understood by reference to Figs. 6, 8, and 10 of the drawings.

In practice the groove 9 will preferably  
115 be of a depth equal to about one-half the diameter of the main body portion 4 of the member F, so that the inner bearing-faces 10, formed by said groove, will lie in a plane coincident with the plane of the longitudinal axis of said member, and the transversely-extended portions of the L-shaped locking-  
120 arms will terminate slightly remote from the periphery of the member F to facilitate the interlocking connection of the inner and outer coupling members F and F' of each coupling device.  
125

By constructing the inner coupling member F as shown and described it will be seen  
130 that two bearing-faces 13 and 13' are formed whose planes are transverse and preferably at right angles to the plane of the longitudinal axis of said member, which bearing-faces are, as hereinafter more fully described, adapted for engaging one part of a locking-flange upon the outer member F' for holding

said member against movement in the plane of its longitudinal axis when the two members are assembled, as shown in Figs. 1 and 2 of the drawings.

5 The two inner coupling members F and F' are axially recessed, as shown at 12, to receive a screw 12', which secures said inner members together and to the hub D of the door-lock, one of said members being tapped to receive the screw-threaded end of said screw. When said inner members are secured in place relatively to the hub D, the short stem or angular projection 5 of said members fit the angular recess in said hub, as shown in Figs. 1, 2, and 3 of the drawings.

Each outer coupling member F', in the preferred form thereof herein shown, consists of the cross-sectionally-rectangular stem 14, adapted to enter and fit the usual central opening in the stem of the knob applied thereto, and a segmental circumferential flange 15 at the extreme end of said stem 14. This circumferential flange, in the form thereof herein shown, is T-shaped in end elevation and constitutes the locking-flange for coacting with the locking-arms 6 and 6' on the inner coupling member F, said flange having bearing-faces 16 and 16' in the plane of the longitudinal axis of said member and adapted to fit between the bearing-faces 7 and 7' of the inner member when the two members F and F' are interlocked together, and also has bearing-faces 17 and 17' in a plane transverse to the longitudinal axis of said member and adapted to fit between and coact with the bearing-faces 13 and 13' of the inner coupling member F when said two members F and F' are assembled. These two sets of transversely-disposed bearing-faces 7 and 7' and 16 and 16' coact to prevent relative rotative movement of the two members F and F' when said members are interlocked, and the bearing-faces 13 and 13' and 17 and 17' of the two members F and F', respectively, coact to prevent a movement of the two members longitudinally of their axes when said members are interlocked together.

It will further be seen that when the two members F and F' are in interlocked engagement the lower faces 18 of that part of the locking-flange 15 of the outer member F' which lies between the bearing-faces 13 and 13' of the inner member F has a firm bearing upon the bearing-faces 10 of said inner member F, which bearing-faces 10, together with the bearing-faces 13 and 13', support and hold the member F' in axial alignment with the member and relieve the elongated bearing G, which circumferentially surrounds the two members F and F' at their junction, from undue strain, as in all cases the two members will be so assembled that the bearing 18 on the flange 15 of the member F' will bear down upon the bearing-face 10 of the member F.

The stem 14 of each outer member F' and

F' is shown having a series of screw-holes 20 formed therethrough, which are tapped to receive the threaded end of a screw 21, which extends through the knob-stem, as illustrated in Figs. 1 and 2 of the drawings, and adjustably secures said member F' to the door-knob.

By the construction and organization of coupling members herein described and shown in the drawings it will be seen that the two coupling members F and F' when interlocked are capable of movement relatively to each other in but one direction—a direction laterally of the longitudinal axes of said members.

As a means for holding said members against movement laterally of each other when interlocked together an elongated tubular bearing G is provided, which circumferentially engages both members F and F' and covers the joint between said members, as shown most clearly in Fig. 2 of the drawings. This bearing is shown formed integrally with the escutcheon-plate G', which is fixed to the door and extends some distance beyond the opposite side faces of said plate, as shown at 22 and 22'. The escutcheon-plate may, in a general way, be of any suitable configuration.

The perimeters of the interlocking ends of the two coupling members F and F' are intended to lie in the same longitudinal plane flush with each other when said two members are interlocked, so that the two members, when interlocked together, form at their junction a cross-sectionally-circular symmetrical journal adapted to fit the bearing G.

The bearing G will, in practice, be of substantially the same internal diameter as the external diameter of, and will be fitted to slide freely upon, the knob-stem, as will be seen by reference to Figs. 1, 2, and 4 of the drawings, said knob-stem being of sufficient length to permit the bearing G to be slid outwardly thereon a sufficient distance to disengage the inner coupling member F.

In assembling the knob attachment in operative relation with the door-lock the two inner coupling members F and F' are first applied to the latch-actuating hub, one at either side thereof, with their short stems 5 seated in the central recess of said hub, and are rigidly fixed together in this position by means of the screw 12', after which each outer coupling member F', together with the knob carried thereby, will be placed in the position—relatively to the inner coupling member—illustrated in Fig. 4, and then moved downward in a direction laterally of the longitudinal axis of the inner member, which brings the lower part of the locking-flange 15 of the outer member F' between the bearing-faces 13 and 13' of the inner member and into locked engagement with said member, after which the bearing G, which has been carried upon the knob-stem during this operation, will be shifted inwardly to the position shown in Figs. 1 and 2, so as to cover the joint between the two

members F and F', and will then be secured by means of suitable screws (not shown) to the face of the door. A reversal of this operation, it will be obvious, will effect the dis-  
5 assembling of the parts of the knob attachment.

It will be understood that the door B will have an opening 25 communicating with the lock-mortise, and of sufficient diameter to  
10 permit the requisite lateral movement of the outer member F' relative to the inner member F. (See Figs. 1 and 2 of the drawings.)

By providing the coupling member F' with an elongated cross-sectionally-rectangular  
15 stem of standard knob-spindle size the coupling device—of which said member constitutes a part—may be readily applied to any ordinary door-knob without any change being  
20 made therein, and by providing an adjustable connection between the said coupling device and door-knob the knob attachment may be readily adjusted and applied to doors of different thicknesses.

Having thus described my invention, I  
25 claim—

1. A knob attachment comprehending a knob and two longitudinally-interlocked, laterally-separable coupling members, one of which is adjustably secured to said knob and  
30 means for normally holding said members against relative lateral movement.

2. A knob attachment comprehending a knob-stem; two normally-interlocked, laterally-separable coupling members, one of  
35 which is adjustably secured to the knob-stem; and a bearing circumferentially engaging said two coupling members, and normally holding said members against relative lateral movement.

3. In a knob attachment, the combination with two knobs, of a duplex knob-connector consisting of two substantially-duplicate coupling devices, and each of which devices  
40 consists of two normally-interlocked, laterally-separable coupling members, one of which members of each coupling device is adjustably secured to a knob.

4. In a knob attachment, a coupling device consisting of an inner and outer coupling  
50 member, the inner member of which has, at one end thereof, a cross-sectionally-angular stem to fit a similar recess in a latch-actuating hub, and also has, at the opposite end thereof, two outwardly-projecting L-shaped  
55 locking-arms, one located at each side of the longitudinal axis of said member, and the outer member of which has, at one end thereof, an angular stem adapted for engaging a hub, and has, at the opposite end thereof, a  
60 segmentally-circular, circumferential locking-flange adapted for engaging between and interlocking with the L-shaped locking-arm upon the inner member.

5. In a knob attachment, an axially-recessed coupling member bifurcated at one  
65 end, and having a relatively shallow transverse slot traversing said bifurcation at some

distance from the extreme end of said member, combined with another coupling member  
70 having a T-shaped locking-flange at the extreme end thereof, which projects in two directions beyond the periphery of the main body of said member, and which is adapted,  
one portion thereof for fitting between the end  
75 portions of the first-mentioned member, and the other portion of which is adapted for fitting the traverse groove in said first-mentioned member.

6. In a knob attachment, a coupling member having a groove in one end thereof inter-  
80 secting the axis and extending from side to side of said member, and also having a relatively shallow groove in the periphery thereof at right angles to and communicating with  
85 said end groove and likewise extending from side to side of said member; combined with another coupling member having a transversely-extending T-shaped end adapted to  
interlock with the grooved member.

7. The combination with a latch-actuating  
90 hub having a cross-sectionally-angular central opening, of a knob attachment comprising two substantially independent coupling devices located, one at each side of said hub,  
95 and having cross-sectionally-angular portions fitting the opening in said hub, and each coupling device consisting of two laterally-separable coupling members, each member  
100 having a set of bearing-faces located in a plane longitudinally of the axis of said member, and also having a set of bearing-faces located in a plane transversely of the plane of  
the axis of said member, and the sets of one  
105 member normally interlocking with the corresponding sets of the other member; an elongated bearing in circumferential engagement with, and holding the two members of, each  
coupling device against relative lateral movement; and knobs carried at the outer end of  
110 each coupling device.

8. In a knob attachment, an inner coupling member having two sets of plane locking-  
115 faces extending transversely of each other; combined with an outer coupling member having two sets of plane locking-faces also extending transversely of each other and in normal locked engagement with the inner coupling  
120 member, and adapted to be released from locked engagement by a movement of one member laterally of the other member; and a sleeve-bearing of the same internal diameter from end to end thereof and circumferentially engaging each of said interlocked members and adapted for movement longitudinally  
125 of said members.

9. The combination with a latch-actuating hub having a cross-sectionally-angular central opening, of two axially-recessed, inner  
130 coupling members having angular projections seated, one in each end of the opening of said hub; a screw passing through one of said members and engaging the other member to lock said members together and to said  
hub, and each coupling member having a

particircular, peripherally-slotted and longitudinally-bifurcated outer end; two outer coupling members having two sets of bearing-faces located in relatively transverse planes  
5 and normally engaging in the peripheral groove, and between the separated walls of the bifurcated end, of the inner coupling members, respectively; a hub adjustably secured to each outer coupling member; and a  
10 sleeve-like bearing shiftably supported upon

the stem of each hub and adapted for circumferentially engaging the two interlocked ends of the adjacent coupling members and for normally holding said members against relative lateral movement.

CHARLES F. DOEBLER.

Witnesses:

FRED. J. DOLE,  
HENRY BISSELL.