



(51) International Patent Classification:
F25J 3/00 (2006.01)

(21) International Application Number:
PCT/US2010/044137

(22) International Filing Date:
2 August 2010 (02.08.2010)

(25) Filing Language: English

(26) Publication Language: English

(30) Priority Data:
61/257,277 2 November 2009 (02.11.2009) US

(71) Applicant (for all designated States except US):
EXXONMOBIL UPSTREAM RESEARCH COMPANY [US/US]; Corp-urc-sw359, P.O. Box 2189, Houston, TX 77252-2189 (US).

(72) Inventors; and

(75) Inventors/Applicants (for US only): **NORTHROP, Paul, Scott** [US/US]; 134 W. Stockbridge Landing, Spring, TX 77382 (US). **KELLEY, Bruce, T.** [US/US]; 5619 Rocky Brook, Kingwood, TX 77345 (US). **MART, Charles, J.** [US/US]; 1633 Lichester Drive, Baton Rouge, LA 70810 (US).

(74) Agents: **MCARTHUR, Douglas, W.** et al.; Exxonmobil Upstream Research Company, Corp-urc-sw359, P.O. Box 2189, Houston, TX 77252-2189 (US).

(81) Designated States (unless otherwise indicated, for every kind of national protection available): AE, AG, AL, AM, AO, AT, AU, AZ, BA, BB, BG, BH, BR, BW, BY, BZ, CA, CH, CL, CN, CO, CR, CU, CZ, DE, DK, DM, DO, DZ, EC, EE, EG, ES, FI, GB, GD, GE, GH, GM, GT, HN, HR, HU, ID, IL, IN, IS, JP, KE, KG, KM, KN, KP, KR, KZ, LA, LC, LK, LR, LS, LT, LU, LY, MA, MD, ME, MG, MK, MN, MW, MX, MY, MZ, NA, NG, NI, NO, NZ, OM, PE, PG, PH, PL, PT, RO, RS, RU, SC, SD, SE, SG, SK, SL, SM, ST, SV, SY, TH, TJ, TM, TN, TR, TT, TZ, UA, UG, US, UZ, VC, VN, ZA, ZM, ZW.

(84) Designated States (unless otherwise indicated, for every kind of regional protection available): ARIPO (BW, GH, GM, KE, LR, LS, MW, MZ, NA, SD, SL, SZ, TZ, UG, ZM, ZW), Eurasian (AM, AZ, BY, KG, KZ, MD, RU, TJ, TM), European (AL, AT, BE, BG, CH, CY, CZ, DE, DK, EE, ES, FI, FR, GB, GR, HR, HU, IE, IS, IT, LT, LU, LV, MC, MK, MT, NL, NO, PL, PT, RO, SE, SI, SK, SM, TR), OAPI (BF, BJ, CF, CG, CI, CM, GA, GN, GQ, GW, ML, MR, NE, SN, TD, TG).

Declarations under Rule 4.17:

[Continued on next page]

(54) Title: CRYOGENIC SYSTEM FOR REMOVING ACID GASES FROM A HYDROCARBON GAS STREAM, WITH REMOVAL OF HYDROGEN SULFIDE

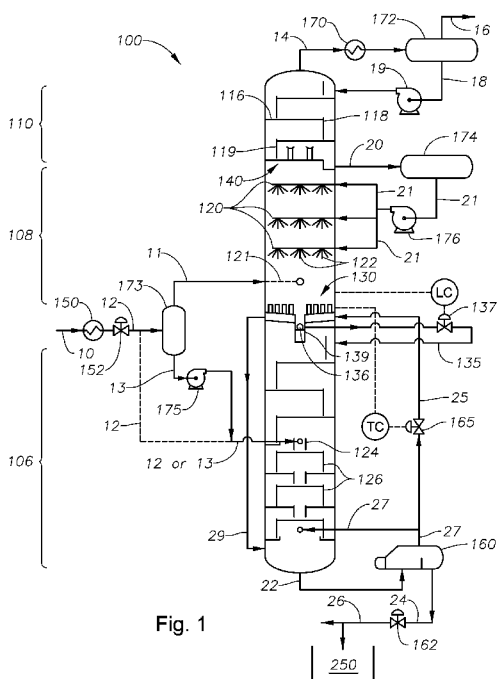

Fig. 1

(57) Abstract: A system for removing acid gases from a raw gas stream includes an acid gas removal system (AGRS) and a sulfurous components removal system (SCRS). The acid gas removal system receives a sour gas stream and separates it into an overhead gas stream comprised primarily of methane, and a bottom acid gas stream comprised primarily of carbon dioxide. The sulfurous components removal system is placed either upstream or downstream of the acid gas removal system. The SCRS receives a gas stream and generally separates the gas stream into a first fluid stream comprising hydrogen sulfide, and a second fluid stream comprising carbon dioxide. Where the SCRS is upstream of the AGRS, the second fluid stream also includes primarily methane. Where the SCRS is downstream of the AGRS, the second fluid stream is principally carbon dioxide. Various types of sulfurous components removal systems may be utilized.

WO 2011/053400 A1

- *as to applicant's entitlement to apply for and be granted a patent (Rule 4.17(ii))*
 - *as to the applicant's entitlement to claim the priority of the earlier application (Rule 4.17(iii))*
- Published:**
- *with international search report (Art. 21(3))*

**CRYOGENIC SYSTEM FOR REMOVING ACID GASES FROM A
HYDROCARBON GAS STREAM, WITH REMOVAL OF HYDROGEN SULFIDE**

Cross-Reference To Related Application

[0001] This application claims the benefit of U.S. Provisional Patent Application
5 61/257,277 filed 2 November 2009 entitled CRYOGENIC SYSTEM FOR REMOVING
ACID GASES FROM A HYDROCARBON GAS STREAM, WITH REMOVAL OF
HYDROGEN SULFIDE, the entirety of which is incorporated by reference herein.

Background

[0002] This section is intended to introduce various aspects of the art, which may be
10 associated with exemplary embodiments of the present disclosure. This discussion is
believed to assist in providing a framework to facilitate a better understanding of particular
aspects of the present disclosure. Accordingly, it should be understood that this section
should be read in this light, and not necessarily as admissions of prior art.

Field

15 [0003] The present invention relates to the field of fluid separation. More specifically,
the present invention relates to the separation of both hydrogen sulfide and other acid gases
from a hydrocarbon fluid stream.

Discussion of Technology

[0004] The production of hydrocarbons from a reservoir oftentimes carries with it the
20 incidental production of non-hydrocarbon gases. Such gases include contaminants such as
hydrogen sulfide (H₂S) and carbon dioxide (CO₂). When H₂S and CO₂ are produced as part
of a hydrocarbon gas stream (such as methane or ethane), the gas stream is sometimes
referred to as "sour gas."

[0005] Sour gas is usually treated to remove CO₂, H₂S, and other contaminants before it
25 is sent downstream for further processing or sale. Removal of acid gases creates a
"sweetened" hydrocarbon gas stream. The sweetened stream may be used as an
environmentally-acceptable fuel or as feedstock to a chemicals or gas-to-liquids facility. The
sweetened gas stream may be chilled to form liquefied natural gas, or LNG.

[0006] The gas separation process creates an issue as to the disposal of the separated
30 contaminants. In some cases, the concentrated acid gas (consisting primarily of H₂S and

CO₂) is sent to a sulfur recovery unit (“SRU”). The SRU converts the H₂S into benign elemental sulfur. However, in some areas (such as the Caspian Sea region), additional elemental sulfur production is undesirable because there is a limited market. Consequently, millions of tons of sulfur have been stored in large, above-ground blocks in some areas of the world, most notably Canada and Kazakhstan.

[0007] While the sulfur is stored on land, the carbon dioxide associated with the acid gas is oftentimes vented to the atmosphere. However, the practice of venting CO₂ is sometimes undesirable. One proposal to minimizing CO₂ emissions is a process called acid gas injection (“AGI”). AGI means that unwanted sour gases are re-injected into a subterranean formation under pressure and sequestered for potential later use. Alternatively, the carbon dioxide is used to create artificial reservoir pressure for enhanced oil recovery operations.

[0008] To facilitate AGI, it is desirable to have a gas processing facility that effectively separates out the acid gas components from the hydrocarbon gases. However, for “highly sour” streams, that is, production streams containing greater than about 15% or 20% CO₂ and/or H₂S, it can be particularly challenging to design, construct, and operate a facility that can economically separate contaminants from the desired hydrocarbons. Many natural gas reservoirs contain relatively low percentages of hydrocarbons (less than 40%, for example) and high percentages of acid gases, principally carbon dioxide, but also hydrogen sulfide, carbonyl sulfide, carbon disulfide and various mercaptans. In these instances, cryogenic gas processing may be beneficially employed.

[0009] Cryogenic gas processing is a distillation process sometimes used for gas separation. Cryogenic gas separation generates a cooled overhead gas stream at moderate pressures (e.g., 350-550 pounds per square inch gauge (psig)). In addition, liquefied acid gas is generated as a “bottoms” product. Since liquefied acid gas has a relatively high density, hydrostatic head can be beneficially used in an AGI well to assist in the injection process. This means that the energy required to pump the liquefied acid gas into the formation is lower than the energy required to compress low-pressure acid gases to reservoir pressure. Fewer stages of compressors and pumps are required.

[0010] Challenges also exist with respect to cryogenic distillation of sour gases. When CO₂ is present at concentrations greater than about 5 mol. percent at total pressure less than about 700 psig in the gas to be processed, it will freeze out as a solid in a standard cryogenic distillation unit. The formation of CO₂ as a solid disrupts the cryogenic distillation process.

To circumvent this problem, the assignee has previously designed various “Controlled Freeze Zone™” (CFZ™) processes. The CFZ™ process takes advantage of the propensity of carbon dioxide to form solid particles by allowing frozen CO₂ particles to form within an open portion of the distillation tower, and then capturing the particles on a melt tray. As a result, a
5 clean methane stream (along with any nitrogen or helium present in the raw gas) is generated at the top of the tower, while a cold liquid CO₂/H₂S stream is generated at the bottom of the tower. At pressures higher than about 700 psig, “bulk fractionation” distillation can be done without fear of CO₂ freezing; however, the methane generated overhead will have at least several percent of CO₂ in it.

10 [0011] Certain aspects of the CFZ™ process and associated equipment are described in U.S. Pat. No. 4,533,372; U.S. Pat. No. 4,923,493; U.S. Pat. No. 5,062,270; U.S. Pat. No. 5,120,338; and U.S. Pat. No. 6,053,007.

[0012] As generally described in the above U.S. patents, the distillation tower, or column, used for cryogenic gas processing includes a lower distillation zone and an intermediate
15 controlled freezing zone. Preferably, an upper distillation zone is also included. The column operates to create solid CO₂ particles by providing a portion of the column having a temperature range below the freezing point of carbon dioxide, but above the boiling temperature of methane at that pressure. More preferably, the controlled freezing zone is operated at a temperature and pressure that permits methane and other light hydrocarbon
20 gases to vaporize, while causing CO₂ to form frozen (solid) particles.

[0013] As the gas feed stream moves up the column, frozen CO₂ particles break out of the feed stream and gravitationally descend from the controlled freezing zone onto a melt tray. There, the particles liquefy. A carbon dioxide-rich liquid stream then flows from the melt tray down to the lower distillation zone at the bottom of the column. The lower distillation
25 zone is maintained at a temperature and pressure at which substantially no carbon dioxide solids are formed, but dissolved methane boils out. In one aspect, a bottom acid gas stream is created at 30° to 40° F.

[0014] In one embodiment, some or all of the frozen CO₂ particles may be collected on a tray at the bottom of the freezing zone. The particles are then transported out of the
30 distillation tower for further processing.

[0015] The controlled freezing zone includes a cold liquid spray. This is a methane-enriched liquid stream known as “reflux.” As the vapor stream of light hydrocarbon gases

and entrained sour gases moves upward through the column, the vapor stream encounters the liquid spray. The cold liquid spray aids in breaking out solid CO₂ particles while permitting methane gas to evaporate and flow upward in the column.

5 [0016] In the upper distillation zone, the methane (or overhead gas) is captured and piped away for sale or made available for fuel. In one aspect, the overhead methane stream is released at about -130° F. The overhead gas may be partially liquefied by additional cooling, and the liquid returned to the column as the reflux. The liquid reflux is injected as the cold spray into the spray section of the controlled freezing zone, usually after flowing through trays or packing of the rectification section of the column.

10 [0017] The methane produced in the upper distillation zone meets most specifications for pipeline delivery. For example, the methane can meet a pipeline CO₂ specification of less than 2 mol. percent, as well as a 4 ppm H₂S specification, if sufficient reflux is generated and/or if there are enough stages of separation from packing or trays in the upper distillation zone. However, if the original raw gas stream contains hydrogen sulfide (or other sulfur-
15 containing compounds), these will end up in the liquid bottom stream of carbon dioxide and hydrogen sulfide.

[0018] Hydrogen sulfide is a poisonous gas that is heavier than air. It is corrosive to well and surface equipment. When hydrogen sulfide contacts metal pipes and valves in the presence of water, iron sulfide corrosion can occur. Therefore, it is desirable to remove
20 hydrogen sulfide and other sulfurous components from the raw gas stream before it enters the cold distillation column. This allows a “sweeter” gas stream to be fed into the column. The CO₂ generated by the cryogenic process is thus substantially free of H₂S, and can be used for enhanced oil recovery, for example.

[0019] There is a need for a system to reduce the content of H₂S and mercaptans from a
25 raw natural gas stream before it undergoes cryogenic distillation for the removal of sour gases. There alternatively is a need for a cryogenic gas separation system and accompanying processes that extract hydrogen sulfide from the acid gas bottom stream downstream from a CFZ tower.

SUMMARY

30 [0020] A system for removing acid gases from a sour gas stream is provided. In one embodiment, the system includes an acid gas removal system. The acid gas removal system utilizes a cryogenic distillation tower that separates the sour gas stream into an overhead gas

stream comprised primarily of methane, and a liquefied bottom acid gas stream comprised primarily of carbon dioxide. The system also includes a sulfurous components removal system. The sulfurous components removal system is placed upstream of the acid gas removal system. The sulfurous components removal system receives a raw gas stream and
5 generally separates the raw gas stream into a fluid stream having hydrogen sulfide and a sour gas stream.

[0021] The sour gas stream preferably comprises between about 4 ppm and 100 ppm sulfurous components. Such components may be hydrogen sulfide, carbonyl sulfide, and various mercaptans.

10 [0022] Preferably, the cryogenic acid gas removal system includes a refrigeration system for chilling the sour gas stream before entry into the distillation tower. Preferably, the cryogenic acid gas removal system is a "CFZ" system wherein the distillation tower has a lower distillation zone and an intermediate controlled freezing zone. The intermediate controlled freezing zone, or "spray section," receives a cold liquid spray comprised primarily
15 of methane. The cold spray is a liquid reflux generated from an overhead loop downstream of the distillation tower. Refrigeration equipment is provided downstream of the cryogenic distillation tower for cooling the overhead methane stream and returning a portion of the overhead methane stream to the cryogenic distillation tower as the cold liquid reflux.

[0023] It is understood that other acid gas removal systems besides cryogenic distillation
20 systems may be employed. For example, the acid gas removal system may be a physical solvent system which is also prone to rejecting H₂S along with CO₂. The acid gas removal system may employ bulk fractionation.

[0024] Various types of sulfurous components removal systems may be utilized. These include systems that employ physical solvents to separate sulfur-containing components from
25 a sour gas stream. These may also include redox processes, and the use of so-called scavengers. These may also include a so-called "CrystaSulf" process.

[0025] In one aspect, the sulfurous components removal system comprises at least one solid adsorbent bed. The at least one solid adsorbent bed adsorbs at least some hydrogen sulfide while passing methane gas and carbon dioxide as the sour gas stream. The solid
30 adsorbent bed may, for example, (i) be fabricated from a zeolite material, or (ii) comprise at least one molecular sieve. The solid adsorbent bed may incidentally adsorb at least some water.

[0026] The at least one solid adsorbent bed may be an adsorptive kinetic separations bed. Alternatively, the at least one solid adsorbent bed may comprise at least three solid adsorbent beds wherein (i) a first of the at least three solid adsorbent beds is in service for adsorbing sulfurous components, (ii) a second of the at least three solid adsorbent beds undergoes
5 regeneration, and (iii) a third of the at least three solid adsorbent beds is held in reserve to replace the first of the at least three solid adsorbent beds. The regeneration may be part of a thermal-swing adsorption process, part of a pressure-swing adsorption process, or a combination thereof.

[0027] In another embodiment, the sulfurous components removal system employs a
10 chemical solvent such as a selective amine. In this instance, the sulfurous components removal system preferably utilizes a plurality of co-current contacting devices.

[0028] Other types of sulfurous components removal systems may be utilized in lieu of or in addition to a physical solvent or a chemical solvent system. Such systems may include a redox system, the use of at least one solid adsorbent bed, or the use of at least one absorptive
15 kinetic separations bed.

[0029] A separate system for removing acid gases from a sour gas stream is also provided herein. In this system, hydrogen sulfide and other sulfur-containing compounds are substantially removed downstream from an acid gas removal system. The system is designed to process an acid gas stream. The acid gas stream is obtained from a raw gas stream initially
20 comprising between about 4 ppm and 100 ppm sulfurous components.

[0030] In one embodiment, the system includes an acid gas removal system. The acid gas removal system receives the raw gas stream and separates the raw gas stream into an overhead gas stream comprised primarily of methane, and a liquid bottom acid gas stream comprised primarily of carbon dioxide. Hydrogen sulfide will also be present in the bottom
25 acid gas stream. The system also includes a sulfurous components removal system. The sulfurous components removal system is placed downstream of the acid gas removal system. The sulfurous components removal system receives the bottom acid gas stream and generally separates the bottom acid gas stream into a carbon dioxide stream and a separate stream having primarily sulfur-containing compounds.

[0031] Preferably, the acid gas removal system is a cryogenic acid gas removal system. The cryogenic acid gas removal system includes a distillation tower for receiving the raw gas stream, and a refrigeration system for chilling the raw gas stream before entry into the

distillation tower. Preferably, the cryogenic acid gas removal system is a "CFZ" system wherein the distillation tower has a lower distillation zone and an intermediate controlled freezing zone. The intermediate controlled freezing zone, or "spray section," receives a cold liquid spray comprised primarily of methane. The cold spray is a liquid reflux generated from an overhead loop downstream of the distillation tower. Refrigeration equipment is provided downstream of the cryogenic distillation tower for cooling the overhead methane stream and returning a portion of the overhead methane stream to the cryogenic distillation tower as reflux, which is a liquid.

[0032] Various types of sulfurous components removal systems may be utilized. In one aspect, the sulfurous components removal system comprises at least one solid adsorbent bed. The at least one solid adsorbent bed adsorbs at least some sulfur-containing components from the bottom acid gas stream and substantially passes carbon dioxide gas. The solid adsorbent bed may, for example, use adsorptive kinetic separations (AKS). The AKS bed may incidentally adsorb at least some carbon dioxide. In this instance, the AKS sulfurous components removal system preferably also includes a separator such as a gravity separator. The gravity separator separates liquid heavy hydrocarbon components and hydrogen sulfide from gaseous CO₂, for example.

[0033] The solid adsorbent bed may alternatively be an iron sponge to directly react with the H₂S and remove it by forming iron sulfide.

[0034] In another aspect, the sulfurous components removal system comprises an extractive distillation process. The extractive distillation process employs at least two solvent recovery columns. The first column receives the bottom acid gas stream and separates the bottom acid gas stream into a first fluid stream comprised primarily of carbon dioxide, and a second fluid stream comprised primarily of solvent and sulfur-containing compounds.

25 **Brief Description of the Drawings**

[0035] So that the manner in which the present inventions can be better understood, certain illustrations, charts and/or flow charts are appended hereto. It is to be noted, however, that the drawings illustrate only selected embodiments of the inventions and are therefore not to be considered limiting of scope, for the inventions may admit to other equally effective embodiments and applications.

[0036] Figure 1 is a side view of an illustrative CFZ distillation tower, in one embodiment. A chilled raw gas stream is being injected into the intermediate controlled freezing zone of the tower.

[0037] Figure 2A is a plan view of a melt tray, in one embodiment. The melt tray resides
5 within the tower below the controlled freezing zone.

[0038] Figure 2B is a cross-sectional view of the melt tray of Figure 2A, taken across line 2B-2B.

[0039] Figure 2C is a cross-sectional view of the melt tray of Figure 2A, taken across line 2C-2C.

10 [0040] Figure 3 is an enlarged side view of stripping trays in the lower distillation zone of the distillation tower, in one embodiment.

[0041] Figure 4A is a perspective view of a jet tray as may be used in either the lower distillation section or in the upper distillation section of the distillation tower, in one embodiment.

15 [0042] Figure 4B is a side view of one of the openings in the jet tray of Figure 4A.

[0043] Figure 5 is a side view of the intermediate controlled freezing zone of the distillation tower of Figure 1. In this view, two illustrative open baffles have been added to the intermediate controlled freeze zone.

[0044] Figure 6 is a schematic diagram showing a gas processing facility for removing
20 acid gases from a gas stream in accordance with the present invention, in one embodiment. The gas processing facility employs a solvent process upstream of an acid gas removal system.

[0045] Figure 7A provides a detailed schematic diagram of the solvent system of Figure 6, in one embodiment. Here, the solvent system is a physical solvent system that
25 operates to contact a dehydrated gas stream in order to remove hydrogen sulfide.

[0046] Figure 7B provides a detailed schematic diagram of the solvent system of Figure 6, in an alternate embodiment. Here, the solvent system is a chemical solvent system that operates to contact a dehydrated gas stream in order to remove hydrogen sulfide.

[0047] Figure 8 is a schematic diagram showing a gas processing facility for removing
30 acid gases from a gas stream in accordance with the present invention, in one embodiment.

In this arrangement, hydrogen sulfide is removed from a gas stream upstream of an acid gas removal system by means of a redox process.

[0048] Figure 9 is a schematic diagram showing a gas processing facility for removing acid gases from a gas stream in accordance with the present invention, in one embodiment.

5 In this arrangement, hydrogen sulfide is removed from a gas stream upstream of an acid gas removal system by means of a scavenger.

[0049] Figure 10 a schematic diagram showing a gas processing facility for removing acid gases from a gas stream in accordance with the present invention, in one embodiment.

10 In this arrangement, hydrogen sulfide is removed from a gas stream upstream of an acid gas removal system by means of a CrystaSulf process.

[0050] Figure 11 is a schematic diagram showing a gas processing facility for removing acid gases from a gas stream in accordance with the present invention, in one embodiment.

In this arrangement, hydrogen sulfide is removed from a gas stream upstream of an acid gas removal system by means of a thermal swing adsorption system.

15 [0051] Figure 12 is a schematic diagram showing a gas processing facility for removing acid gases from a gas stream in accordance with the present invention, in one embodiment.

In this arrangement, hydrogen sulfide is removed from a gas stream upstream of an acid gas removal system by means of a pressure swing adsorption system.

[0052] Figure 13 is a schematic diagram showing a gas processing facility of the present

20 invention, in another embodiment. In this arrangement, hydrogen sulfide is removed from a gas stream upstream of an acid gas removal system by means of an adsorptive bed that utilizes adsorptive kinetic separation.

[0053] Figure 14 is a schematic diagram showing a gas processing facility of the present invention, in another embodiment. In this arrangement, hydrogen sulfide is removed from a

25 gas stream downstream of an acid gas removal system by means of an adsorptive bed that utilizes adsorptive kinetic separation.

[0054] Figure 15A is a schematic diagram of a gas processing facility of the present invention, in another embodiment. In this arrangement, hydrogen sulfide is removed from a

30 gas stream downstream of an acid gas removal system by means of an extractive distillation process.

[0055] Figure 15B is a detailed schematic diagram of a gas processing facility for the extractive distillation process of Figure 15A.

Detailed Description of Certain Embodiments

Definitions

5 [0056] As used herein, the term "hydrocarbon" refers to an organic compound that includes primarily, if not exclusively, the elements hydrogen and carbon. Hydrocarbons generally fall into two classes: aliphatic, or straight chain hydrocarbons, and cyclic, or closed ring hydrocarbons, including cyclic terpenes. Examples of hydrocarbon-containing materials include any form of natural gas, oil, coal, and bitumen that can be used as a fuel or upgraded
10 into a fuel.

[0057] As used herein, the term "hydrocarbon fluids" refers to a hydrocarbon or mixtures of hydrocarbons that are gases or liquids. For example, hydrocarbon fluids may include a hydrocarbon or mixtures of hydrocarbons that are gases or liquids at formation conditions, at processing conditions or at ambient conditions (15° C and 1 atm pressure). Hydrocarbon
15 fluids may include, for example, oil, natural gas, coal bed methane, shale oil, pyrolysis oil, pyrolysis gas, a pyrolysis product of coal, and other hydrocarbons that are in a gaseous or liquid state.

[0058] The term "mass transfer device" refers to any object that receives fluids to be contacted, and passes those fluids to other objects, such as through gravitational flow. One
20 non-limiting example is a tray for stripping out certain components. A grid packing is another example.

[0059] As used herein, the term "fluid" refers to gases, liquids, and combinations of gases and liquids, as well as to combinations of gases and solids, and combinations of liquids and solids.

25 [0060] As used herein, the term "condensable hydrocarbons" means those hydrocarbons that condense at about 15° C and one atmosphere absolute pressure. Condensable hydrocarbons may include, for example, a mixture of hydrocarbons having carbon numbers greater than 4.

[0061] As used herein, the term "heavy hydrocarbons" refers to hydrocarbons having more
30 than one carbon atom. Principal examples include ethane, propane and butane. Other examples include pentane, aromatics, or diamondoids.

[0062] As used herein, the term "closed loop refrigeration system" means any refrigeration system wherein an external working fluid such as propane or ethylene is used as a coolant to chill an overhead methane stream. This is in contrast to an "open loop refrigeration system" wherein a portion of the overhead methane stream itself is used as the
5 working fluid.

[0063] As used herein, the term "co-current contacting device" or "co-current contactor" means a vessel that receives (i) a stream of gas and (ii) a separate stream of solvent in such a manner that the gas stream and the solvent stream contact one another while flowing in generally the same directions within the contacting device. Non-limiting examples include
10 an eductor and a coalescer, or a static mixer plus deliquidizer.

[0064] "Non-absorbing gas" means a gas that is not significantly absorbed by a solvent during a gas sweetening process.

[0065] As used herein, the term "natural gas" refers to a multi-component gas obtained from a crude oil well (associated gas) or from a subterranean gas-bearing formation (non-
15 associated gas). The composition and pressure of natural gas can vary significantly. A typical natural gas stream contains methane (C_1) as a significant component. The natural gas stream may also contain ethane (C_2), higher molecular weight hydrocarbons, and one or more acid gases. The natural gas may also contain minor amounts of contaminants such as water, nitrogen, wax, and crude oil.

20 [0066] As used herein, an "acid gas" means any gas that dissolves in water producing an acidic solution. Nonlimiting examples of acid gases include hydrogen sulfide (H_2S), and carbon dioxide (CO_2). Sulfurous compounds include carbon disulfide (CS_2), carbonyl sulfide (COS), mercaptans, or mixtures thereof.

[0067] The term "liquid solvent" means a fluid in substantially liquid phase that
25 preferentially absorbs acid gases, thereby removing or "scrubbing" at least a portion of the acid gas components from a gas stream. The gas stream may be a hydrocarbon gas stream or other gas stream, such as a gas stream having nitrogen.

[0068] "Sweetened gas stream" refers to a fluid stream in a substantially gaseous phase that has had at least a portion of acid gas components removed.

30 [0069] As used herein, the terms "lean" and "rich," with respect to the absorbent liquid removal of a selected gas component from a gas stream, are relative, merely implying,

respectively, a lesser or greater degree of content of the selected gas component. The respective terms “lean” and “rich” do not necessarily indicate or require, respectively, either that an absorbent liquid is totally devoid of the selected gaseous component, or that it is incapable of absorbing more of the selected gas component. In fact, it is preferred, as will be evident hereinafter, that the so called "rich" absorbent liquid produced in a first contactor in a series of two or more contactors retains significant or substantial residual absorptive capacity. Conversely, a "lean" absorbent liquid will be understood to be capable of substantial absorption, but may retain a minor concentration of the gas component being removed.

[0070] The term “raw gas stream” refers to a hydrocarbon fluid stream wherein the fluids are primarily in a gaseous phase, and which has not undergone steps to remove carbon dioxide, hydrogen sulfide, or other acidic components.

[0071] The term “sour gas stream” refers to a hydrocarbon fluid stream wherein the fluids are primarily in a gaseous phase, and contain at least 3 mol percent carbon dioxide and/or more than 4 ppm hydrogen sulfide.

[0072] As used herein, the term "subsurface" refers to geologic strata occurring below the earth's surface.

Description of Specific Embodiments

[0073] **Figure 1** presents a schematic view of a cryogenic distillation tower **100** as may be used in connection with the present inventions, in one embodiment. The cryogenic distillation tower **100** may be interchangeably referred to herein as a “cryogenic distillation tower,” a “column,” a “CFZ column,” or just a “tower.”

[0074] The cryogenic distillation tower **100** of **Figure 1** receives an initial fluid stream **10**. The fluid stream **10** is comprised primarily of production gases. Typically, the fluid stream represents a dried gas stream from a wellhead or collection of wellheads (not shown), and contains about 65% to about 95% methane. However, the fluid stream **10** may contain a lower percentage of methane, such as about 30% to 65%, or even as low as 20% to 40%.

[0075] The methane may be present along with trace elements of other hydrocarbon gases such as ethane. In addition, trace amounts of helium and nitrogen may be present. In the present application, the fluid stream **10** will also include certain contaminants. These include acid gases such as CO₂ and H₂S.

[0076] The initial fluid stream **10** may be at a post-production pressure of approximately 600 pounds per square inch (psi). In some instances, the pressure of the initial fluid stream **10** may be up to about 750 psi or even 1,000 psi.

[0077] The fluid stream **10** is typically chilled before entering the distillation tower **100**.
5 A heat exchanger **150**, such as a shell-and-tube exchanger, is provided for the initial fluid stream **10**. A refrigeration unit (not shown) provides cooling fluid (such as liquid propane) to the heat exchanger **150** to bring the temperature of the initial fluid stream **10** down to about -30° to -40° F. The chilled fluid stream may then be moved through an expansion device **152**. The expansion device **152** may be, for example, a Joule-Thompson (“J-T”) valve.

10 [0078] The expansion device **152** serves as an expander to obtain additional cooling of the fluid stream **10**. Preferably, partial liquefaction of the fluid stream **10** is achieved. A Joule-Thompson (or “J-T”) valve is preferred for gas feed streams that are prone to forming solids. The expansion device **152** is preferably mounted close to the cryogenic distillation tower **100** to minimize heat loss in the feed piping and to minimize the chance of plugging
15 with solids in case some components (such as CO₂ or benzene) are dropped below their freezing points.

[0079] As an alternative to a J-T valve, the expander device **152** may be a turbo-expander. A turbo-expander provides greater cooling and creates a source of shaft work for processes like the refrigeration unit mentioned above. The heat exchanger **150** is part of the
20 refrigeration unit. In this manner, the operator may minimize the overall energy requirements for the distillation process. However, the turbo-expander may not handle frozen particles as well as the J-T valve.

[0080] In either instance, the heat exchanger **150** and the expander device **152** convert the raw gas in the initial fluid stream **10** into a chilled fluid stream **12**. Preferably, the
25 temperature of the chilled fluid stream **12** is around -40° to -70° F. In one aspect, the cryogenic distillation tower **100** is operated at a pressure of about 550 psi, and the chilled fluid stream **12** is at approximately -62° F. At these conditions, the chilled fluid stream **12** is in a substantially liquid phase, although some vapor phase may inevitably be entrained into the chilled fluid stream **12**. Most likely, no solids formation has arisen from the presence of
30 CO₂.

[0081] The CFZ cryogenic distillation tower **100** is divided into three primary sections. These are a lower distillation zone, or “stripping section” **106**, an intermediate controlled

freezing zone, or “spray section” **108**, and an upper distillation zone, or “rectification section” **110**. In the tower arrangement of **Figure 1**, the chilled fluid stream **12** is introduced into the distillation tower **100** in the controlled freezing zone **108**. However, the chilled fluid stream **12** may alternatively be introduced near the top of the lower distillation zone **106**.

5 [0082] It is noted in the arrangement of **Figure 1** that the lower distillation zone **106**, the intermediate spray section **108**, the upper distillation zone **110**, and the related components are housed within a single vessel **100**. However, for offshore applications in which height of the tower **100** and motion considerations may need to be considered, or for remote locations in which transportation limitations are an issue, the tower **110** may optionally be split into
10 two separate pressure vessels (not shown). For example, the lower distillation zone **106** and the controlled freezing zone **108** may be located in one vessel, while the upper distillation zone **108** is in another vessel. External piping would then be used to interconnect the two vessels.

[0083] In either embodiment, the temperature of the lower distillation zone **106** is higher
15 than the feed temperature of the chilled fluid stream **12**. The temperature of the lower distillation zone **106** is designed to be well above the boiling point of the methane in the chilled fluid stream **12** at the operating pressure of the column **100**. In this manner, methane is preferentially stripped from the heavier hydrocarbon and liquid acid gas components. Of course, those of ordinary skill in the art will understand that the liquid within the distillation
20 tower **100** is a mixture, meaning that the liquid will “boil” at some intermediate temperature between pure methane and pure CO₂. Further, in the event that there are heavier hydrocarbons present in the mixture (such as ethane or propane), this will increase the boiling temperature of the mixture. These factors become design considerations for the operating temperatures within the cryogenic distillation tower **100**.

25 [0084] In the lower distillation zone **106**, the CO₂ and any other liquid-phase fluids gravitationally fall towards the bottom of the cryogenic distillation tower **100**. At the same time, methane and other vapor-phase fluids break out and rise upwards towards the top of the tower **100**. This separation is accomplished primarily through the density differential between the gas and liquid phases. However, the separation process is optionally aided by
30 internal components within the distillation tower **100**. As described below, these include a melt tray **130**, a plurality of advantageously-configured mass transfer devices **126**, and an

optional heater line **25**. A side reboiler (see at **173**) may likewise be added to the lower distillation zone **106** to facilitate removal of methane.

[0085] Referring again to **Figure 1**, the chilled fluid stream **12** may be introduced into the column **100** near the top of the lower distillation zone **106**. Alternatively, it may be desirable
5 to introduce the feed stream **12** into the controlled freezing zone **108** above the melt tray **130**. The point of injection of the chilled fluid stream **12** is a design issue dictated primarily by the composition of the initial fluid stream **10**.

[0086] Where the temperature of the chilled fluid stream **12** is high enough (such as greater than -70° F) such that solids are not expected, it may be preferable to inject the chilled
10 fluid stream **12** directly into the lower distillation zone **106** through a two-phase flashbox type device (or vapor distributor) **124** in the column **100**. The use of a flashbox **124** serves to at least partially separate the two-phase vapor-liquid mixture in the chilled fluid stream **12**. The flashbox **124** may be slotted such that the two-phase fluid impinges against baffles in the flashbox **124**.

[0087] If solids are anticipated due to a low inlet temperature, the chilled fluid stream **12**
15 may need to be partially separated in a vessel **173** prior to feeding the column **100** as described above. In this case, the chilled feed stream **12** may be separated in a two phase separator **173** to minimize the possibility of solids plugging the inlet line and internal components of the column **100**. Gas vapor leaves the phase separator **173** through a vessel
20 inlet line **11**, where it enters the column **100** through an inlet distributor **121**. The gas then travels upward through the column **100**. A liquid/solid slurry **13** is discharged from the phase separator **173**. The liquid/solid slurry is directed into the column **100** through the vapor distributor **124** and to the melt tray **130**. The liquid/solid slurry **13** can be fed to the column **100** by gravity or by a pump **175**.

[0088] In either arrangement, that is, with or without the two phase separator **173**, the
25 chilled fluid stream **12** (or **11**) enters the column **100**. The liquid component leaves the flashbox **124** and travels down a collection of stripping trays **126** within the lower distillation zone **106**. The stripping trays **126** include a series of weirs **128** and downcomers **129**. These are described more fully below in connection with **Figure 3**. The stripping trays **126**, in
30 combination with the warmer temperature in the lower distillation zone **106**, cause methane to break out of solution. The resulting vapor carries the methane and any entrained carbon dioxide molecules that have boiled off.

[0089] The vapor further proceeds upward through risers or chimneys **131** of the melt tray **130** (seen in **Figure 2B**) and into the freeze zone **108**. The chimneys **131** act as a vapor distributor for uniform distribution through the freeze zone **108**. The vapor will then contact cold liquid from spray headers **120** to “freeze out” the CO₂. Stated another way, CO₂ will freeze and then precipitate or “snow” back onto the melt tray **130**. The solid CO₂ then melts and gravitationally flows in liquid form down the melt tray **130** and through the lower distillation zone **106** there below.

[0090] As will be discussed more fully below, the spray section **108** is an intermediate freeze zone of the cryogenic distillation tower **100**. With the alternate configuration in which the chilled fluid stream **12** is separated in vessel **173** prior to entering the tower **100**, a part of the separated liquid/solid slurry **13** is introduced into the tower **100** immediately above the melt tray **130**. Thus, a liquid-solid mixture of acid gas and heavier hydrocarbon components will flow from the distributor **121**, with solids and liquids falling down onto the melt tray **130**.

[0091] The melt tray **130** is configured to gravitationally receive liquid and solid materials, primarily CO₂ and H₂S, from the intermediate controlled freezing zone **108**. The melt tray **130** serves to warm the liquid and solid materials and direct them downward through the lower distillation zone **106** in liquid form for further purification. The melt tray **130** collects and warms the solid-liquid mixture from the controlled freezing zone **108** in a pool of liquid. The melt tray **130** is designed to release vapor flow back to the controlled freezing zone **108**, to provide adequate heat transfer to melt the solid CO₂, and to facilitate liquid/slurry drainage to the lower distillation or lower distillation zone **106** of the column **100** below the melt tray **130**.

[0092] **Figure 2A** provides a plan view of the melt tray **130**, in one embodiment. **Figure 2B** provides a cross-sectional view of the melt tray **130**, taken across line **B-B** of **Figure 2A**. **Figure 2C** shows a cross-sectional view of the melt tray **130**, taken across line **C-C**. The melt tray **130** will be described with reference to these three drawings collectively.

[0093] First, the melt tray **130** includes a base **134**. The base **134** may be a substantially planar body. However, in the preferred embodiment shown in **Figures 2A, 2B** and **2C**, the base **134** employs a substantially non-planar profile. The non-planar configuration provides an increased surface area for contacting liquids and solids landing on the melt tray **130** from the controlled freezing zone **108**. This serves to increase heat transfer from the vapors

passing up from the lower distillation zone **106** of the column **100** to the liquids and thawing solids. In one aspect, the base **134** is corrugated. In another aspect, the base **134** is substantially sinusoidal. This aspect of the tray design is shown in **Figure 2B**. It is understood that other non-planar geometries may alternatively be used to increase the heat transfer area of the melt tray **130**.

[0094] The melt tray base **134** is preferably inclined. The incline is demonstrated in the side view of **Figure 2C**. Although most solids should be melted, the incline serves to ensure that any unmelted solids in the liquid mixture drain off of the melt tray **130** and into the distillation zone **106** there below.

10 [0095] In the view of **Figure 2C**, a sump or channel **138** is seen central to the melt tray **130**. The melt tray base **134** slopes inwardly towards the channel **138** to deliver the solid-liquid mixture. The base **134** may be sloped in any manner to facilitate gravitational liquid draw-off.

[0096] As described in U.S. Pat. No. 4,533,372, the melt tray was referred to as a
15 “chimney tray.” This was due to the presence of a single venting chimney. The chimney provided an opening through which vapors may move upward through the chimney tray. However, the presence of a single chimney meant that all gases moving upward through the chimney tray had to egress through the single opening. On the other hand, in the melt tray **130** of **Figures 2A, 2B** and **2C**, a plurality of chimneys **131** is provided. The use of multiple
20 chimneys **131** provides improved vapor distribution. This contributes to better heat/mass transfer in the intermediate controlled freezing zone **108**.

[0097] The chimneys **131** may be of any profile. For instance, the chimneys **131** may be round, rectangular, or any other shape that allows vapor to pass through the melt tray **130**. The chimneys **131** may also be narrow and extend upwards into the controlled freezing zone
25 **108**. This enables a beneficial pressure drop to distribute the vapor evenly as it rises into the CFZ controlled freezing zone **108**. The chimneys **131** are preferably located on peaks of the corrugated base **134** to provide additional heat transfer area.

[0098] The top openings of the chimneys **131** are preferably covered with hats or caps **132**. This minimizes the chance that solids dropping from the controlled freezing zone **108**
30 can avoid falling onto the melt tray **130**. In **Figures 2A, 2B** and **2C**, caps **132** are seen above each of the chimneys **131**.

[0099] The melt tray **130** may also be designed with bubble caps. The bubble caps define convex indentations in the base **134** rising from underneath the melt tray **130**. The bubble caps further increase surface area in the melt tray **130** to provide additional heat transfer to the CO₂-rich liquid. With this design, a suitable liquid draw off, such as an increased incline
5 angle, should be provided to insure that liquid is directed to the stripping trays **126** below.

[0100] Referring again to **Figure 1**, the melt tray **130** may also be designed with an external liquid transfer system. The transfer system serves to ensure that all liquid is substantially free of solids and that sufficient heat transfer has been provided. The transfer system first includes a draw-off nozzle **136**. In one embodiment, the draw-off nozzle **136**
10 resides within the draw-off sump, or channel **138** (shown in **Figure 2C**). Fluids collected in the channel **138** are delivered to a transfer line **135**. Flow through the transfer line **135** may be controlled by a control valve **137** and a level controller "LC" (seen in **Fig. 1**). Fluids are returned to the lower distillation zone **106** via the transfer line **135**. If the liquid level is too high, the control valve **137** opens; if the level is too low, the control valve **137** closes. If the
15 operator chooses not to employ the transfer system in the lower distillation zone **106**, then the control valve **137** is closed and fluids are directed immediately to the mass transfer devices, or "stripping trays" **126** below the melt tray **130** for stripping via an overflow downcomer **139**.

[0101] Whether or not an external transfer system is used, solid CO₂ is warmed on the
20 melt tray **130** and converted to a CO₂-rich liquid. The melt tray **130** is heated from below by vapors from the lower distillation zone **106**. Supplemental heat may optionally be added to the melt tray **130** or just above the melt tray base **134** by various means such as heater line **25**. The heater line **25** utilizes thermal energy already available from a bottom reboiler **160** to facilitate thawing of the solids.

[0102] The CO₂-rich liquid is drawn off from the melt tray **130** under liquid level control and gravitationally introduced to the lower distillation zone **106**. As noted, a plurality of stripping trays **126** are provided in the lower distillation zone **106** below the melt tray **130**. The stripping trays **126** are preferably in a substantially parallel relation, one above the other. Each of the stripping trays **126** may optionally be positioned at a very slight incline, with a
30 weir such that a liquid level is maintained on the tray. Fluids gravitationally flow along each tray, over the weir, and then flow down onto the next tray via a downcomer.

[0103] The stripping trays **126** may be in a variety of arrangements. The stripping trays **126** may be arranged in generally horizontal relation to form a back-and-forth, cascading

liquid flow. However, it is preferred that the stripping trays **126** be arranged to create a cascading liquid flow that is divided by separate stripping trays substantially along the same horizontal plane. This is shown in the arrangement of **Figure 3**, where the liquid flow is split at least once so that liquid flows across separate trays and falls into two opposing
5 downcomers **129**.

[0104] **Figure 3** provides a side view of a stripping tray **126** arrangement, in one embodiment. Each of the stripping trays **126** receives and collects fluids from above. Each stripping tray **126** preferably has a weir **128** that serves as a dam to enable the collection of a small pool of fluid on each of the stripping trays **126**. The buildup may be $\frac{1}{2}$ to 1 inch,
10 though any height may be employed. A waterfall effect is created by the weirs **128** as fluid falls from one tray **126** on to a next lower tray **126**. In one aspect, no incline is provided to the stripping trays **126**, but the waterfall effect is created through a higher weir **128** configuration. The fluid is contacted with upcoming vapor rich in lighter hydrocarbons that strip out the methane from the cross flowing liquid in this “contact area” of the trays **126**.
15 The weirs **128** serve to dynamically seal the downcomers **129** to help prevent vapor from bypassing through the downcomers **129** and to further facilitate the breakout of hydrocarbon gases.

[0105] The percentage of methane in the liquid becomes increasingly small as the liquid moves downward through the lower distillation zone **106**. The extent of distillation depends
20 on the number of trays **126** in the lower distillation zone **106**. In the upper part of the lower distillation zone **106**, the methane content of the liquid may be as high as 25 mol percent, while at the bottom stripping tray the methane content may be as low as 0.04 mol percent. The methane content flashes out quickly along the stripping trays **126** (or other mass transfer devices). The number of mass transfer devices used in the lower distillation zone **106** is a
25 matter of design choice based on the composition of the raw gas stream **10**. However, only a few levels of stripping trays **126** need be typically utilized to remove methane to a desired level of 1% or less in the liquefied acid gas, for example.

[0106] Various individual stripping tray **126** configurations that facilitate methane breakout may be employed. The stripping tray **126** may simply represent a panel with sieve
30 holes or bubble caps. However, to provide further heat transfer to the fluid and to prevent unwanted blockage due to solids, so called “jet trays” may be employed below the melt tray. In lieu of trays, random or structured packing may also be employed.

[0107] **Figure 4A** provides a plan view of an illustrative jet tray **426**, in one embodiment. **Figure 4B** provides a cross-sectional view of a jet tab **422** from the jet tray **426**. As shown, each jet tray **426** has a body **424**, with a plurality of jet tabs **422** formed within the body **424**. Each jet tab **422** includes an inclined tab member **428** covering an opening **425**. Thus, a jet tray **426** has a plurality of small openings **425**.

[0108] In operation, one or more jet trays **426** may be located in the lower distillation zone **106** and/or the upper distillation zone **110** of the tower **100**. The trays **426** may be arranged with multiple passes such as the pattern of stripping trays **126** in **Figure 3**. However, any tray or packing arrangement may be utilized that facilitates the breakout of methane gas. Fluid cascades down upon each jet tray **426**. The fluids then flow along the body **424**. The tabs **422** are optimally oriented to move the fluid quickly and efficiently across the tray **426**. An adjoined downcomer (not shown) may optionally be provided to move the liquid to the subsequent tray **426**. The openings **425** also permit gas vapors released during the fluid movement process in the lower distillation zone **106** to travel upwards more efficiently to the melt tray **130** and through the chimneys **131**.

[0109] In one aspect, the trays (such as trays **126** or **426**) may be fabricated from fouling-resistant materials, that is, materials that prevent solids-buildup. Fouling-resistant materials are utilized in some processing equipment to prevent the buildup of corrosive metal particles, polymers, salts, hydrates, catalyst fines, or other chemical solids compounds. In the case of the cryogenic distillation tower **100**, fouling resistant materials may be used in the trays **126** or **426** to limit sticking of CO₂ solids. For example, a Teflon™ coating may be applied to the surface of the trays **126** or **426**.

[0110] Alternatively, a physical design may be provided to ensure that the CO₂ does not start to build up in solid form along the inner diameter of the column **100**. In this respect, the jet tabs **422** may be oriented to push liquid along the wall of the column **100**, thereby preventing solids accumulation along the wall of the column **100** and ensuring good vapor-liquid contact.

[0111] In any of the tray arrangements, as the down-flowing liquid hits the stripping trays **126**, separation of materials occurs. Methane gas breaks out of solution and moves upward in vapor form. The CO₂, however, is generally cold enough and in high enough concentration that it mostly remains in its liquid form and travels down to the bottom of the lower distillation zone **106**, although some CO₂ will necessarily be vaporized in the process. The

liquid is then moved out of the cryogenic distillation tower **100** in an exit line as a bottoms fluid stream **22**.

[0112] Upon exiting the distillation tower **100**, the bottoms fluid stream **22** enters a reboiler **160**. In **Figure 1**, the reboiler **160** is a kettle-type vessel that provides reboiled vapor to the bottom of the stripping trays. A reboiled vapor line is seen at **27**. In addition, reboiled vapor may be delivered through a heater line **25** to provide supplemental heat to the melt tray **130**. The supplemental heat is controlled through a valve **165** and temperature controller **TC**. Alternatively, a heat exchanger, such as a thermosyphon heat exchanger (not shown) may be used to cool the initial fluid stream **10** to economize energy. In this respect, the liquids entering the reboiler **160** remain at a relatively low temperature, for example, about 30° to 40° F. By heat integrating with the initial fluid stream **10**, the operator may warm and partially boil the cool bottoms fluid stream **22** from the distillation tower **100** while pre-cooling the production fluid stream **10**. For this case, the fluid providing supplemental heat through line **25** is a vapor phase return from the reboiler **160**.

[0113] It is contemplated that under some conditions, the melt tray **130** may operate without heater line **25**. In these instances, the melt tray **130** may be designed with an internal heating feature such as an electric heater. However, it is preferred that a heat system be offered that employs the heat energy available in the bottoms fluid stream **22**. The warm fluids in heater line **25** exist in one aspect at 30° to 40° F, so they contain relative heat energy. Thus, in **Figure 1**, a warm vapor stream in heater line **25** is shown being directed to the melt tray **130** through a heating coil (not shown) on the melt tray **130**. The warm vapor stream may alternatively be tied to the transfer line **135**.

[0114] In operation, most of the reboiled vapor stream is introduced at the bottom of the column through line **27**, above the bottom liquid level and at or below the last stripping tray **126**. As the reboiled vapor passes upward through each tray **126**, residual methane is stripped out of the liquid. This vapor cools off as it travels up the tower. By the time the vapor stream from line **27** reach the corrugated melt tray **130**, the temperature may drop to about -20° F to 0° F. However, this remains quite warm compared to the melting solid on the melt tray **130**, which may be around -50° F to -70° F. The vapor still has enough enthalpy to melt the solids CO₂ as it comes in contact with the melt tray **130**.

[0115] Referring back to reboiler **160**, fluids in a bottom stream **24** that exit the reboiler **160** in liquid form may optionally pass through an expander valve **162**. The expander valve

162 reduces the pressure of the bottom liquid product, effectively providing a refrigeration effect. Thus, a chilled bottom stream 26 is provided. The CO₂-rich liquid exiting the reboiler 160 may be pumped downhole through one or more AGI wells (seen schematically at 250 in Figure 1). In some situations, the liquid CO₂ may be pumped into a partially recovered oil reservoir as part of an enhanced oil recovery process. Thus, the CO₂ could be a miscible injectant. As an alternative, the CO₂ may be used as a miscible flood agent for enhanced oil recovery.

[0116] Referring again to the lower distillation zone 106 of the tower 100, gas moves up through the lower distillation zone 106, through the chimneys 131 in the melt tray 130, and into the controlled freezing zone 108. The controlled freezing zone 108 defines an open chamber having a plurality of spray nozzles 122. As the vapor moves upward through the controlled freezing zone 108, the temperature of the vapor becomes much colder. The vapor is contacted by liquid methane (“reflux”) coming from the spray nozzles 122. This liquid methane is much colder than the upwardly-moving vapor, having been chilled by an external refrigeration unit that includes a heat exchanger 170. In one arrangement, the liquid methane exits from spray nozzles 122 at a temperature of approximately -120° F to -130° F. However, as the liquid methane evaporates, it absorbs heat from its surroundings, thereby reducing the temperature of the upwardly-moving vapor. The vaporized methane also flows upward due to its reduced density (relative to liquid methane) and the pressure gradient within the distillation tower 100.

[0117] As the methane vapors move further up the cryogenic distillation tower 100, they leave the intermediate controlled freezing zone 108 and enter the upper distillation zone 110. The vapors continue to move upward along with other light gases broken out from the original chilled fluid stream 12. The combined hydrocarbon vapors move out of the top of the cryogenic distillation tower 100, becoming an overhead methane stream 14.

[0118] The hydrocarbon gas in overhead methane stream 14 is moved into the external refrigeration unit 170. In one aspect, the refrigeration unit 170 uses an ethylene refrigerant or other refrigerant capable of chilling the overhead methane stream 14 down to about -135° to -145° F. This serves to at least partially liquefy the overhead methane stream 14. The refrigerated methane stream 14 is then moved to a reflux condenser or separation chamber 172.

[0119] The separation chamber 172 is used to separate gas 16 from liquid, referred to sometimes as “liquid reflux” 18. The gas 16 represents the lighter hydrocarbon gases, primarily methane, from the original raw gas stream 10. Nitrogen and helium may also be present. The methane gas 16 is, of course, the “product” ultimately sought to be captured and sold commercially, along with any traces of ethane. This non-liquefied portion of the overhead methane stream 14 is also available for fuel on-site.

[0120] A portion of the overhead methane stream 14 exiting the refrigeration unit 170 is condensed. This portion is the liquid reflux 18 that is separated in the separation chamber 172 and returned to the tower 100. A pump 19 may be used to move the liquid reflux 18 back into the tower 100. Alternatively, the separation chamber 172 is mounted above the tower 100 to provide a gravity feed of the liquid reflux 18. The liquid reflux 18 will include any carbon dioxide that escaped from the upper distillation zone 110. However, most of the liquid reflux 18 is methane, typically 95% or more, with nitrogen (if present in the initial fluid stream 10) and traces of hydrogen sulfide (if also present in the initial fluid stream 10).

[0121] In one cooling arrangement, the overhead methane stream 14 is taken through an open-loop refrigeration system, such as the refrigeration system shown in and described in connection with Figure 6. In this arrangement, the overhead methane stream 14 is taken through a cross-exchanger to chill a return portion of the overhead methane stream used as the liquid reflux 18. Thereafter, the overhead methane stream 14 is pressurized to about 1,000 psi to 1,400 psi, and then cooled using ambient air and possibly an external propane refrigerant. The pressurized and chilled gas stream is then directed through an expander for further cooling. A turbo expander may be used to recover even more liquid as well as some shaft work. U.S. Pat. No. 6,053,007 entitled “Process For Separating a Multi-Component Gas Stream Containing at Least One Freezable Component,” describes the cooling of an overhead methane stream, and is incorporated herein in its entirety by reference.

[0122] It is understood here that the present inventions are not limited by the cooling method for the overhead methane stream 14. It is also understood that the degree of cooling between refrigeration unit 170 and the initial refrigeration unit 150 may be varied. In some instances, it may be desirable to operate the refrigeration unit 150 at a higher temperature, but then be more aggressive with cooling the overhead methane stream 14 in the refrigeration unit 170. Again, the present inventions are not limited to these types of design choices.

[0123] Returning again to **Figure 1**, the liquid reflux **18** is returned into the upper distillation zone **110**. The liquid reflux **18** is then gravitationally carried through one or more mass transfer devices **116** in the upper distillation zone **110**. In one embodiment, the mass transfer devices **116** are rectification trays that provide a cascading series of weirs **118** and downcomers **119**, similar to trays **126** described above.

[0124] As fluids from the liquid reflux stream **18** move downward through the rectification trays **116**, additional methane vaporizes out of the upper distillation zone **110**. The methane gases rejoin the overhead methane stream **14** to become part of the gas product stream **16**. However, the remaining liquid phase of the liquid reflux **18** falls onto a collector tray **140**. As it does so, the liquid reflux stream **18** unavoidably will pick up a small percentage of hydrocarbon and residual acid gases moving upward from the controlled freezing zone **108**. The liquid mixture of methane and carbon dioxide is collected at a collector tray **140**.

[0125] The collector tray **140** preferably defines a substantially planar body for collecting liquids. However, as with melt tray **130**, collector tray **140** also has one, and preferably a plurality of chimneys for venting gases coming up from the controlled freezing zone **108**. A chimney and cap arrangement such as that presented by components **131** and **132** in **Figures 2B** and **2C** may be used. Chimneys **141** and caps **142** for collector tray **140** are shown in the enlarged view of **Figure 5**, discussed further below.

[0126] It is noted here that in the upper distillation zone **110**, any H₂S present has a preference towards being dissolved in the liquid versus being in the gas at the processing temperature. In this respect, the H₂S has a comparatively low relative volatility. By contacting the remaining vapor with more liquid, the cryogenic distillation tower **100** drives the H₂S concentration down to within the desired parts-per-million (ppm) limit, such as a 10 or even a 4 ppm specification. As fluid moves through the mass transfer devices **116** in the upper distillation zone **110**, the H₂S contacts the liquid methane and is pulled out of the vapor phase and becomes a part of the liquid stream **20**. From there, the H₂S moves in liquid form downward through the lower distillation zone **106** and ultimately exits the cryogenic distillation tower **100** as part of the liquefied acid gas bottoms stream **22**. . For those cases where little to no H₂S is present in the feed stream, or if H₂S is selectively removed by an upstream process, virtually no H₂S will be present in the overhead gas.

[0127] In the cryogenic distillation tower **100**, the liquid captured at collector tray **140** is drawn out of the upper distillation zone **110** as a liquid stream **20**. The liquid stream **20** is comprised primarily of methane. In one aspect, the liquid stream **20** is comprised of about 93 mol. percent methane, 3% CO₂, 0.5% H₂S, and 3.5% N₂. At this point, the liquid stream **20** is at about -125° F to -130° F. This is only slightly warmer than the liquid reflux stream **18**. The liquid stream **20** is directed into a reflux drum **174**. The purpose of the reflux drum **174** is to provide surge capacity for a pump **176**. Upon exiting the reflux drum **174**, a spray stream **21** is created. Spray stream **21** is pressurized in a pump **176** for a second reintroduction into the cryogenic distillation tower **100**. In this instance, the spray stream **21** is pumped into the intermediate controlled freezing zone **108** and emitted through nozzles **122**.

[0128] Some portion of the spray stream **21**, particularly the methane, vaporizes and evaporates upon exiting the nozzles **122**. From there, the methane rises through the controlled freezing zone **108**, through the chimneys in the collector tray **140**, and through the mass transfer devices **116** in the upper distillation zone **110**. The methane leaves the distillation tower **100** as the overhead methane stream **14** and ultimately becomes part of the commercial product in gas stream **16**.

[0129] The spray stream **21** from the nozzles **122** also causes carbon dioxide to desublime from the gas phase. In this respect, CO₂ initially dissolved in the liquid methane may momentarily enter the gas phase and move upward with the methane. However, because of the cold temperature within the controlled freezing zone **108**, any gaseous carbon dioxide quickly nucleates and agglomerates into a solid phase and begins to "snow." This phenomenon is referred to as desublimation. In this way, some CO₂ never re-enters the liquid phase until it hits the melt tray **130**. This carbon dioxide "snows" upon the melt tray **130**, and melts into the liquid phase. From there, the CO₂-rich liquid cascades down the mass transfer devices or trays **126** in the lower distillation zone **106**, along with liquid CO₂ from the chilled raw gas stream **12** as described above. At that point, any remaining methane from the spray stream **21** of the nozzles **122** should quickly break out into vapor. These vapors move upwards in the cryogenic distillation tower **100** and re-enter the upper distillation zone **110**.

[0130] It is desirable to have chilled liquid contacting as much of the gas that is moving up the tower **100** as possible. If vapor bypasses the spray stream **21** emanating from the nozzles **122**, higher levels of CO₂ could reach the upper distillation zone **110** of the tower

100. To improve the efficiency of gas/liquid contact in the controlled freezing zone **108**, a plurality of nozzles **122** having a designed configuration may be employed. Thus, rather than employing a single spray source at one or more levels with the reflux fluid stream **21**, several spray headers **120** optionally designed with multiple spray nozzles **122** may be used. Thus, the configuration of the spray nozzles **122** has an impact on the heat and mass transfer taking place within the controlled freezing zone **108**. Also, the nozzles themselves can be designed to generate optimal droplet sizes and areal distribution of those droplets.

[0131] The assignee herein has previously proposed various nozzle arrangements in co-pending WO Pat. Publ. No. 2008/091316 having an international filing date of November 20, 2007. That application and Figures 6A and 6B are incorporated herein by reference for teachings of the nozzle configurations. The nozzles seek to ensure 360° coverage within the controlled freezing zone **108** and provide good vapor-liquid contact and heat/mass transfer. This, in turn, more effectively chills any gaseous carbon dioxide moving upward through the cryogenic distillation tower **100**.

[0132] The use of multiple headers **120** and a corresponding overlapping nozzle **122** arrangement for complete coverage minimizes back-mixing as well. In this respect, complete coverage prevents the fine, low-mass CO₂ particles from moving back up the distillation tower **100** and re-entering the upper distillation zone **110**. These particles would then remix with methane and re-enter the overhead methane stream **14**, only to be recycled again.

[0133] The above acid gas removal system described in connection with **Figure 1** is profitable for producing a commercial methane product **16** that is substantially free of acid gases. The product **16** is preferably liquefied and sent down a pipeline for sale. The liquefied gas product preferably meets a pipeline CO₂ specification of 1 to 4 mol. percent, where sufficient reflux is generated. Carbon dioxide and hydrogen sulfide are removed through bottoms stream **22**.

[0134] In some cases, small quantities of H₂S are present with relatively large amounts of CO₂ in the raw initial fluid stream **10**. In this case, it may be desirable to selectively remove the H₂S ahead of the cryogenic distillation tower in order that a "clean" liquid CO₂ stream may be produced at the bottoms stream **22**. In this way, the CO₂ may be directly injected into a reservoir for enhanced oil recovery ("EOR") operations. Therefore, systems and methods are proposed herein for removing a portion of the sulfurous components that are produced

with the initial fluid stream **10** before acid gas removal takes place in a cryogenic distillation tower such as tower **100**.

[0135] A number of H₂S-selective processes are proposed herein for the removal of sulfurous components from a gas stream. Both aqueous and non-aqueous processes are described. Preferably, the processes remove any sulfhydryl compounds such as hydrogen sulfide (H₂S), and organosulfur compounds having a sulfhydryl (--SH) group, known as mercaptans, also known as thiols (R—SH), where R is a hydrocarbon group.

[0136] A first method for removing sulfurous components upstream of an acid gas removal system employs the use of solvents. Certain solvents have an affinity for hydrogen sulfide and can be used to separate H₂S from methane. The solvents may be either physical solvents or chemical solvents.

[0137] **Figure 6** is a schematic diagram showing a gas processing facility **600** for removing acid gases from a gas stream, in one embodiment. The gas processing facility **600** employs a solvent process upstream of an acid gas removal system. The acid gas removal system is indicated generally by **650**, while the solvent process is indicated by the Block **605**. The acid gas removal system **650** includes a separation vessel at Block **100**. Block **100** is indicative generally of the controlled freeze zone tower **100** of **Figure 1**. However, Block **100** may also represent any cryogenic distillation tower such as a bulk fractionation tower.

[0138] In **Figure 6**, a production gas stream is shown at **612**. The gas stream **612** originates from hydrocarbon production activities that take place in a reservoir development area, or “field” **610**. It is understood that the field **610** may represent any location where gaseous hydrocarbons are produced.

[0139] The field **610** may be onshore, near shore or offshore. The field **610** may be operating from original reservoir pressure or may be undergoing enhanced recovery procedures. The systems and methods claimed herein are not limited to the type of field that is under development so long as it is producing hydrocarbons contaminated with hydrogen sulfide and carbon dioxide. The hydrocarbons will comprise primarily methane, but may also include 2 to 10 mol. percent ethane and other heavy hydrocarbons such as propane or even trace amounts of butane and aromatic hydrocarbons.

[0140] The gas stream **612** is “raw,” meaning that it has not undergone an acid gas removal processes. The raw gas stream **612** may be passed through a pipeline, for example, from the field **610** to the gas processing facility **600**. Upon arrival at the gas processing

facility **600**, the gas stream **612** may be directed through a dehydration process such as a glycol dehydration vessel. A dehydration vessel is shown schematically at **620**. As a result of passing the raw gas stream **612** through the dehydration vessel **620**, an aqueous stream **622** is generated. In some cases, the raw gas stream **612** may be mixed with monoethylene glycol (MEG) in order to prevent water drop-out and hydrate formation. The MEG may be sprayed on a chiller, for example, and the liquids collected for separation into water, more concentrated MEG, and possibly some heavy hydrocarbons, depending on the temperature of the chiller and the inlet gas composition.

[0141] The aqueous stream **622** may be sent to a water treatment facility. Alternatively, the aqueous stream **622** may be re-injected into a subsurface formation. A subsurface formation is indicated at block **630**. Alternatively still, the removed aqueous stream **622** may be treated to meet environmental standards and then released into the local watershed (not shown) as treated water.

[0142] Also, as a result of passing the production gas stream **612** through the dehydration vessel **620**, a substantially dehydrated methane gas stream **624** is produced. The dehydrated gas stream **624** may contain trace amounts of nitrogen, helium and other inert gases. In connection with the present systems and methods, the dehydrated gas stream **624** also includes carbon dioxide and small amounts of hydrogen sulfide. The gas stream **624** may contain other sulfurous components such as carbonyl sulfide, carbon disulfide, sulfur dioxide, and various mercaptans.

[0143] The dehydrated gas stream **624** is optionally passed through a preliminary refrigeration unit **625**. The refrigeration unit **625** chills the dehydrated gas stream **624** down to a temperature of about 20° F to 50° F. The refrigeration unit **625** may be, for example, an air cooler or an ethylene or a propane refrigerator.

[0144] It is desirable to remove the sulfurous components from the dehydrated gas stream **624** to prevent iron sulfide corrosion. In accordance with the gas processing facility **600**, a solvent system **605** is provided. The dehydrated gas stream **624** enters the solvent system **605**. The solvent system **605** contacts the gas stream **624** with a solvent to remove hydrogen sulfide through a process of absorption. This takes place at relatively low temperatures and relatively high pressures wherein the solubility of the acid gas components is greater than that of methane.

[0145] As noted, the solvent system **605** may be either a physical solvent system or a chemical solvent system. **Figure 7A** provides a schematic diagram of a physical solvent system **705A**, in one embodiment. The physical solvent system **705A** operates to contact the dehydrated gas stream **624** in order to remove sulfurous components.

5 [0146] Examples of suitable physical solvents include N-methyl pyrrolidone, propylene carbonate, methyl cyanoacetate, and refrigerated methanol. A preferred example of a physical solvent is sulfolane, having a chemical name of tetramethylene sulfone. Sulfolane is an organosulfur compound containing a sulfonyl functional group. The sulfonyl group is a sulfur atom doubly bonded to two oxygen atoms. The sulfur-oxygen double bond is highly
10 polar, allowing for high solubility in water. At the same time, the four-carbon ring provides affinity for hydrocarbons. These properties allow sulfolane to be miscible in both water and hydrocarbons, resulting in its widespread use as a solvent for purifying hydrocarbon mixtures.

[0147] A preferred physical solvent is Selexol™. Selexol™ is a trade name for a gas
15 treating product of Union Carbide, a subsidiary of Dow Chemical Company. Selexol™ solvent is a mixture of dimethyl ethers of polyethylene glycols. An example of one such component is dimethoxy tetraethylene glycol. Selexol® will also pick up any heavy hydrocarbons in the initial fluid stream **10** as well as some water. Where the initial fluid stream **10** is fairly dry to begin with, the use of Selexol™ may eliminate the need for other
20 dehydration. It is noted here that if the Selexol™ solvent is chilled and then pre-saturated with CO₂, the Selexol™ solvent will be selective towards H₂S.

[0148] Referring to **Figure 7A**, a dehydrated gas stream **624** can be seen entering an inlet separator **660**. It is understood that it is desirable to keep the gas stream **624** clean so as to prevent foaming of liquid solvent during the acid gas removal process. Therefore, the inlet
25 separator **660** is used to filter out liquid impurities such oil-based drilling fluids and mud. Some particle filtration may also take place. Brine is preferably knocked out using the upstream dehydration vessel **620**. However, the inlet separator **660** may remove any condensed hydrocarbons.

[0149] Liquids such as drilling fluids and condensed hydrocarbons drop out of the bottom
30 of the inlet separator **660**. A liquid impurities stream is seen at **662**. Water-based impurities are typically sent to a water treatment facility (not shown), or may be reinjected into the formation **630** to sustain reservoir pressure or for disposal. Hydrocarbon liquids are generally

sent to a condensate treating facility. Gas exits from the top of the inlet separator **660**. A cleaned gas stream is seen at **664**.

[0150] The cleaned gas stream **664** is optionally directed into a gas-to-gas exchanger **665**. The gas-to-gas exchanger **665** pre-cools the gas in the cleaned gas stream **664**. The cleaned gas is then directed into an absorber **670**. The absorber **670** is preferably a counter-current contacting tower that receives an absorbent. In the arrangement of **Figure 7A**, the cleaned gas stream **664** enters at the bottom of the tower **670**. At the same time, the physical solvent **696** enters at the top of the tower **670**. The tower **670** may be a trayed tower, a packed tower, or other type of tower.

10 [0151] It is understood that any number of non-tower devices designed for gas-liquid contact may alternatively be utilized. These may include static mixers and co-current contacting devices. The counter-current tower **670** of **Figure 7A** is merely for illustrative purposes. Of note, the use of compact, co-current contactors for the gas-liquid contacting vessel(s) is preferred as such can reduce the overall footprint and weight of the physical
15 solvent system **705A**.

[0152] The absorbent may be, for example, a solvent that mixes with the cleaned gas stream **664** to “knock out” H₂S and, incidentally, some CO₂. The absorbent may specifically be Selexol[®] as discussed above. As a result of the contacting process with the absorbent, a light gas stream **678** is generated. The light gas stream **678** comes out of the top of the tower
20 **670**. The light gas stream **678** contains methane and carbon dioxide. The light gas stream **678** goes through a refrigeration process before being directed to the cryogenic distillation tower, shown schematically at Block **100** in **Figure 6**.

[0153] Referring momentarily back to **Figure 6**, the light gas stream **678** exits the physical solvent system **705A** and passes through a chiller **626**. The chiller **626** chills the
25 light gas stream **678** down to a temperature of about -30° F to -40° F. The chiller **626** may be, for example, an ethylene or a propane refrigerator.

[0154] The light gas stream **678** is next preferably moved through an expansion device **628**. The expansion device **628** may be, for example, a Joule-Thompson (“J-T”) valve. The expansion device **628** serves as an expander to obtain further cooling of the light gas stream
30 **678**. The expansion device **628** further reduces the temperature of the light gas stream **678** down to, for example, about -70° F to -80° F. Preferably, at least partial liquefaction of the gas stream **678** is also accomplished. A cooled sour gas stream is produced at line **611**.

[0155] Referring again to **Figure 7A**, the contacting tower **670** will pick up sulfurous components. These are released from the bottom of the tower **670** as a "rich" solvent. A rich solvent stream **672** is seen exiting the tower **670**. The rich solvent stream **672** may include some carbon dioxide as well.

5 [0156] In the arrangement of **Figure 7A**, the rich solvent stream **672** is carried through a power recovery turbine **674**. This allows electrical energy to be generated for the physical solvent system **705A**. From there, the rich solvent stream **672** is carried through a series of flash separators **680**. In the illustrative arrangement of **Figure 7A**, three separators are shown at **682**, **684** and **686**. The separators **682**, **684**, **686** operate at progressively lower
10 temperatures and pressures in accordance with the physical solvent process.

[0157] The first separator **682** may operate, for example, at a pressure of 500 psi and a temperature of 90° F. The first separator **682** releases light gases entrained in the rich solvent stream **672**. These light gases, shown at **681**, comprise primarily methane and carbon dioxide, but may have trace amounts of H₂S. The light gases **681** may be directed to the
15 cryogenic distillation tower **100** (not shown in **Figure 7A**). These gases may be combined with the light gas stream **678**. The light gases **681** preferably travel through a compressor **690** to boost pressure en route to the cryogenic distillation tower **100** as stream **611**. Compression may not be necessary if the distillation tower **100** is operated at a lower pressure than the first flash stage, that is, the first separator **682**, of the solvent process **705A**.
20 In that case, a pressure drop will be required for overhead stream **678** in order that the streams **681** and **678** may be combined. This pressure drop may be induced by a J-T valve near the cryogenic distillation tower **100**. Of course, the stream **681** will have to be introduced downstream of the J-T valve.

[0158] Ideally, all hydrogen sulfide and any heavy hydrocarbons from the cleaned gas
25 stream **664** have been captured with the rich solvent stream **672**. A progressively richer solvent stream is released from each separator **682**, **684**, **686**. These progressively rich streams are denoted at lines **683**, **685** and **687**. Thus, the physical solvent is generally regenerated by pressure reduction, causing any dissolved methane and carbon dioxide to flash from the solvent.

30 [0159] Line **687** is a "semi-lean" solvent stream because some of the CO₂ has been removed, but the solvent stream **687** has not been fully regenerated. A portion of this solvent stream **687** is carried through a booster pump **692** and reintroduced into the contacting tower

670 as a semi-lean solvent at an intermediate level in the contacting tower. The remaining portion, shown at 693, is directed into a regenerating vessel 652.

[0160] In connection with the second 684 and third 686 of the three separators, it is noted that each of these separators 684, 686 also releases very small amounts of light gases. These light gases will primarily include carbon dioxide with small amounts of methane. These light gases are shown in two separate lines at 689. The light gases 689 may be compressed and combined with line 611 and then be directed into the cryogenic distillation tower 100. Alternatively, the light gases from lines 689 may be delivered directly to a bottom liquefied acid gas stream shown at 642 in Figure 6.

10 [0161] One advantage of using a physical solvent for upstream H₂S removal is that the solvent is generally hygroscopic. This may eliminate the need for a gas dehydration vessel 620, particularly where the initial fluid stream 10 is already substantially dry. To this end, it is preferable that the selected solvent itself be non-aqueous. In this way, the solvent may be used to further dehydrate the raw natural gas. In this case, water may come out in a vapor stream 655 from the regenerator 652.

[0162] A disadvantage of this process is that some light hydrocarbons and CO₂ will be co-adsorbed in the physical solvent to some extent. The use of multiple separators 682, 684, 686 does remove most of the methane from the rich solvent stream 672, but typically not all of it.

20 [0163] Referring again to the regenerating vessel 652, the vessel 652 acts as a stripper. Hydrogen sulfide components are driven off so that they exit the regenerating vessel 652 through vapor stream 655 as a concentrated H₂S stream. The concentrated H₂S in vapor stream 655 is shown exiting the physical solvent system 705A. It is also shown at line 655 in Figure 6.

25 [0164] The concentrated H₂S in vapor stream 655 is preferably sent to an acid gas injection (AGI) facility. A second physical solvent process may optionally be used beforehand to remove any CO₂ and water vapor. A separator is shown at 658. The separator 658 is a reflux vessel that recovers condensed water and solvent while allowing gas to go overhead. The condensed water and solvent may be returned to the regenerating vessel 652 through bottom line 659. At the same time, the overhead gas may be sent to acid gas injection (shown schematically at Block 649 of Figure 6, and discussed below) through line 691.

[0165] The vapor stream 655 will also include carbon dioxide. The carbon dioxide and any water vapor will exit the separator 658 through the overhead line 691 along with the H₂S. The H₂S is preferably sent downstream to the AGI facility 649, or may optionally be sent to a sulfur recovery unit (SRU) (not shown).

5 [0166] The regenerating vessel 652 depicted in **Figure 7A** may utilize a stripping gas to separate sulfurous components from solvent. The regenerating vessel 652 can be fed with any number of stripping gases. An example is a fuel gas stream with a high-CO₂ content. A high-CO₂ content fuel gas is preferred for the stripping gas 651 as it may help "pre-saturate" the solvent with CO₂, thereby leading to less CO₂ pickup from the cleaned gas stream 664. A
10 stripping gas is seen being fed into the regenerating vessel 652 through line 651'. The stripping gas 651' may be, for example a portion of the light gas stream 689 from the lowest-pressure flash stage, that is, separator 686. This allows for a potential recovery of some of the hydrocarbons.

[0167] Regenerated solvent is directed from the bottom of the regenerating vessel 652.
15 The regenerated solvent exits as 653. The regenerated solvent 653 is carried through a booster pump 654. Optionally, a second booster pump 694 is utilized to further step up pressure in the line carrying regenerated solvent 653. Thereafter, the regenerated solvent 653 is preferably cooled through a heat exchanger 695, possibly having a refrigeration unit. A chilled and regenerated solvent 696 is then recycled back into the contactor 670.

20 [0168] A portion of the regenerated solvent is taken from the bottom of the regenerating vessel 652 and sent to a reboiler 697. The reboiler warms the solvent. The warmed solvent is returned to the regenerating vessel 697 through line 651'' as a partially vaporized stream.

[0169] **Figure 7A** demonstrates an embodiment of a physical solvent system 705A. However, as noted, the solvent system 605 may alternatively be a chemical solvent system.
25 The chemical solvent system would use chemical solvents, particularly H₂S-selective amines. Examples of such selective amines include methyl diethanol amine (MDEA) and the Flexsorb[®] family of amines. Flexsorb[®] is a trade name for a chemical sorbent used in the removal of sulfurous gases from a sour gas mixture. A Flexsorb[®] sorbent or other amine is contacted with the hydrocarbon gas stream 624 or a cleaned gas stream 664 upstream of a
30 cryogenic distillation tower.

[0170] Amine-based solvents rely on a chemical reaction with acid gas components in the hydrocarbon gas stream. The reaction process is sometimes referred to as "gas sweetening."

Such chemical reactions are generally more effective than physical-based solvents, particularly at feed gas pressures below about 300 psia (2.07 MPa).

[0171] Flexsorb[®] amines are preferred chemical solvents for selectively removing H₂S from CO₂-containing gas streams. Flexsorb[®] amines take advantage of the relatively fast rate of H₂S absorption compared to CO₂ absorption. The fast absorption rate helps to prevent the formation of carbamates. The hydrogen sulfide generated from amine-based processes is generally at low pressure. The output H₂S will undergo either sulfur recovery, or underground disposal which requires significant compression.

[0172] The removal of hydrogen sulfide using a selective amine may be accomplished by contacting the dehydrated and chilled fluid stream 624 with the chemical solvent. This may be done by injecting the gas stream 624 into an “absorber.” The absorber is a vessel that allows gas from the gas stream 624 to be contacted by the Flexsorb[™] or other liquid amine. As the two fluid materials interact, the amine absorbs H₂S from the sour gas to produce a sweetened gas stream. The sweetened gas stream contains primarily methane and carbon dioxide. This “sweet” gas flows out of the top of the absorber.

[0173] In one aspect, the absorber is a large, counter-current contacting tower. In this arrangement, the raw gas stream 624 is injected into the bottom of the contacting tower, while the chemical solvent, or “lean solvent stream,” is injected into the top of the contacting tower. Once inside the counter-flowing contacting tower, gas from the gas stream 624 moves upward through the absorber. Typically, one or more trays or other internals (not shown) are provided within the absorber to create multiple flow paths for the natural gas and to create interfacial area between the gas and liquid phases. At the same time, the liquid from the lean solvent stream moves downward and across the succession of trays in the absorber. The trays aid interaction of the natural gas with the solvent stream. This process is demonstrated in connection with Figure 1 of a patent application entitled “Removal of Acid Gases From a Gas Stream.” That application was filed provisionally on October 14, 2008, and is assigned U.S. Serial No. 61/105,343. Figure 1 and the corresponding portions of the Specification are incorporated herein by reference.

[0174] A “rich” amine solution drops out of the bottom of the counter-current contacting tower. This comprises the liquid amine along with absorbed H₂S. The rich amine solution is taken through a regeneration process that may look considerably like the regeneration

components described in **Figure 7A**, above, in connection with the physical solvent system **705A**, though it typically has only a single flash vessel operating at 100-200 psig

[0175] The counter-current contactor tower used as an absorber for H₂S scrubbing tends to be very large and heavy. This creates particular difficulty in offshore oil and gas production applications. Accordingly, an alternate embodiment for H₂S removal from hydrocarbon gas streams incident to oil and gas recovery is proposed herein. That involves the use of smaller, co-current contacting devices. These devices can improve the selectivity of the amine by reducing contact time, thus reducing the chance for CO₂ to be absorbed. These smaller absorber devices can also reduce the size of the overall footprint of the process

10 **605**.

[0176] **Figure 7B** demonstrates an illustrative embodiment of a chemical solvent system **705B** as may be used for the solvent process **605** of **Figure 6**. The chemical solvent system **705B** employs a series of co-flowing contacting devices **CD1**, **CD2**, . . . , **CD(n-1)**, **CDn**. These devices are used to contact the selective amine with the gas stream.

15 [0177] The co-current flow concept utilizes two or more contactors in series wherein a sour gas stream and a liquid solvent move together within the contactors. In one embodiment, the sour gas stream and the liquid solvent move together generally along the longitudinal axis of the respective contactors. Co-current flow contactors can operate at much higher fluid velocities. As a result, co-current flow contactors tend to be smaller than

20 counter-current flow contactors that utilize packed or trayed towers.

[0178] As with **Figure 7A**, a dehydrated gas stream **624** can be seen entering an inlet separator **660**. The inlet separator **660** serves to filter out liquid impurities such oil-based drilling fluids and mud. Brine is preferably knocked out using the upstream dehydration vessel **620**, shown in **Figure 6**. Some particle filtration may also take place in the inlet

25 separator **660**. It is understood that it is desirable to keep the gas stream **624** clean so as to prevent foaming of liquid solvent during the acid gas treatment process.

[0179] Liquids such as condensed hydrocarbons and drilling fluids drop out of the bottom of the inlet separator **660**. A liquid impurities stream is seen at **662**. The water-borne impurities are typically sent to a water treatment facility (not shown), or may be reinjected

30 into the formation **630** with line **622** to sustain reservoir pressure or for disposal. Hydrocarbon liquids typically go to a condensate treater. Gas exits from the top of the inlet separator **660**. A cleaned sour gas stream is seen at **664**.

[0180] The cleaned sour gas is directed into a series of absorbers. Here, the absorbers are co-current contacting devices **CD1**, **CD2**, . . . , **CD(n-1)**, **CDn**. Each contactor **CD1**, **CD2**, . . . , **CD(n-1)**, **CDn** removes a portion of the H₂S content from the gas stream **664**, thereby releasing a progressively sweetened gas stream. A final contactor **CDn** provides a
5 final sweetened gas stream **730(n)** comprising substantially methane and carbon dioxide. Gas stream **730(n)** becomes line **678** of **Figure 6**.

[0181] In operation, the gas stream **664** enters a first co-current absorber, or contacting device, **CD1**. There, gas is mixed with a liquid solvent **720**. The solvent **720** preferably consists of an amine solution such as methyldiethanol amine (MDEA), or a Flexsorb[®] amine.
10 The liquid solvent may also comprise a hindered amine, a tertiary amine, or combinations thereof. Flexsorb[®] is an example of a hindered amine, while MDEA is an example of a tertiary amine. In addition, the solvent stream **720** is a partially regenerated or “semi-lean” solvent produced by a regenerator **750**. Movement of the “semi-lean” solvent **720** into the first contactor **CD1** is aided by a pump **724**. The pump **724** moves the semi-lean solvent **720**
15 into the first contactor **CD1** under suitable pressure. An example of a suitable pressure is about 15 psia to 1,500 psig.

[0182] Once inside the first contactor **CD1**, the gas stream **664** and the chemical solvent stream **720** move along the longitudinal axis of the first contactor **CD1**. As they travel, the liquid amine (or other solvent) interacts with the H₂S in the gas stream **664**, causing the H₂S
20 to chemically attach to or be absorbed by amine molecules. A first “rich” solvent solution **740(1)** drops out of a bottom of the first contactor **CD1**. At the same time, a first partially-sweetened gas stream **730(1)** moves out of the first contactor **CD1** and is released to a second contactor **CD2**.

[0183] The second contactor **CD2** also represents a co-current, separating device.
25 Optionally, a third co-current separating device **CD3** is provided after the second contactor **CD2**. Each of the second and third contactors **CD2**, **CD3** generates a respective partially-sweetened gas stream **730(2)**, **730(3)**. In addition, each of the second and third contactors **CD2**, **CD3** generates a respective partially-loaded gas-treating solution **740(2)**, **740(3)**. Where an amine is used as the solvent, the partially-loaded gas-treating solutions **740(2)**,
30 **740(3)** will comprise rich amine solutions. In the illustrative system **705B**, the second loaded gas-treating solution **740(2)** merges with the first loaded gas-treating solution **740(1)** and goes through a regeneration process, including going through regenerator **750**.

[0184] It is noted that as the gas **664** moves through the progressively-sweetened gas streams **730(1)**, **730(2)**, . . . **730(n-1)** in a downstream direction, pressure in the system will generally decrease. As this happens, the pressure in the progressively-richer amine (or other liquid solvent) streams **740(n)**, **740(n-1)**, . . . **740(2)**, **740(1)** in the upstream direction needs
5 to generally increase to match the gas pressure. It is thus preferred in system **705B** that one or more small booster pumps (not shown) be placed between each of the contactors **CD1**, **CD2**, . . . This will serve to boost liquid pressure in the system.

[0185] In the system **705B**, the streams **740(1)**, **740(2)** comprise "rich" solvent solutions that are first moved through a flash drum **742**. The flash drum **742** operates at a pressure of
10 about 100 to 150 psig. The flash drum **742** typically has internal parts that create a settling effect or a tortuous flow path for the solvent stream **740** therein. Residual gases such as methane and CO₂ are flashed from the solvent stream **740** through line **744**. The residual gases captured in line **744** may be reduced to an acid gas content of about 100 ppm if contacted with a small amount of fresh amine from line **720**, for example. This concentration
15 is small enough that the residual gases can be used as fuel gas for the system **705B**.

[0186] Residual natural gas may be flashed from the solvent stream **740** through line **744**. The resulting rich solvent stream **746** is directed into a regenerator **750**.

[0187] Before moving into the regenerator **750**, the rich solvent stream **746** is preferably moved through a heat exchanger (not shown). The relatively cool (close to ambient
20 temperature) solvent stream **746** may be heated via thermal contact with a warm lean solvent stream **760** exiting the bottom of the regenerator **750**. This, in turn, serves to beneficially cool the lean solvent stream **760** before delivery to a lean solvent cooler **764**, and then to a final contactor **CDn**.

[0188] The regenerator **750** defines a stripper portion **752** comprising trays or other
25 internals (not shown) above a reboiler **756**. A heat source is provided to reboiler **756** to generate heat. The regenerator **750** produces the regenerated or "lean" solvent stream **760** that is recycled for reuse in the final contactor **CDn**. Stripped overhead gas from the regenerator **750** containing concentrated H₂S exits the regenerator **750** as an impurities stream **770**.

30 [0189] The H₂S-rich impurities stream **770** is moved into a condenser **772**. The condenser **772** serves to cool the impurities stream **770**. The cooled impurities stream **770** is moved through a reflux accumulator **774** that separates any remaining liquid (mostly

condensed water) from the impurities stream 770. An acid gas stream 776 is then created that comprises primarily H₂S. The acid gas stream 776 is the same as line 655 of Figure 6.

[0190] Some liquid may be dropped from the reflux accumulator 774. This results in a residual liquid stream 775. The residual liquid stream 775 is preferably carried through a pump 778 to boost pressure where it is then reintroduced into the regenerator 750. Some of the residual liquid will exit the regenerator 750 at the bottom as part of the lean solvent stream 760. Some water content may optionally be added to the lean solvent stream 760 to balance the loss of water vapor to the sweetened gas streams 730(n-1), 730(n). This water may be added at the intake or suction of the reflux pump 778.

10 [0191] The lean or regenerated solvent 760 is at a low pressure. Accordingly, the liquid stream representing regenerated solvent 760 is carried through a pressure boosting pump 762. Pump 762 is referred to as a lean solvent booster 762. From there, the lean solvent 760 passes through a cooler 764. Cooling the solvent via cooler 764 ensures that the lean solvent 760 will absorb acid gases effectively. The chilled lean solvent 760 is used as the solvent stream for the last separating contactor CD_n.

[0192] A solvent tank 722 is optionally provided proximate the contacting devices CD₁, CD₂, . . . , CD(n-1), CD_n. The lean solvent 760 may pass through the solvent tank 722. More preferably, the solvent tank 722 is off-line and provides a reservoir for solvent as it may be needed for the gas facility 705B.

20 [0193] Referring again to the plurality of co-current contacting devices CD₁, CD₂, . . . CD(n-1), CD_n, each contacting device receives a gas stream that includes a hydrocarbon gas and hydrogen sulfide. Each contacting device CD₁, CD₂, . . . CD(n-1), CD_n operates to sequentially remove the H₂S and to produce a progressively sweetened gas stream. The co-current contacting devices CD₁, CD₂, . . . CD(n-1), CD_n may be any of a variety of short contact-time mixing devices. Examples include static mixers and centrifugal mixers. Some mixing equipment breaks the liquid apart through an eductor. The eductor delivers gas through a venturi-like tube that in turn pulls liquid solvent into the tube. Because of the venturi effect, the liquid solvent is dragged in and broken into small droplets, allowing a large surface area of contact with the gas.

30 [0194] One preferred contacting device is the ProsCon™ contactor. This contactor utilizes an eductor followed by a centrifugal coalescer. The centrifugal coalescer induces large centrifugal forces to re-integrate the liquid solvent in a small volume. In whatever

embodiment, compact vessel technology is preferably employed, allowing for a reduction of the hardware in comparison to the large contactor towers.

[0195] The first contactor **CD1** receives the raw gas stream **664**. The gas stream **664** is treated in the first contactor **CD1** for the removal of hydrogen sulfide. A first partially-sweetened gas stream **730(1)** is then released. The first partially-sweetened gas stream **730(1)** is delivered to the second contactor **CD2**. There, the first sweetened gas stream **730(1)** is further treated for the removal of hydrogen sulfide so that a second, more-fully sweetened gas stream **730(2)** is released. This pattern is continued such that a third contactor **CD3** produces a more fully-sweetened gas stream **730(3)**; a fourth contactor **CD4** produces still an even more-sweetened gas stream **730(4)**; and a next-to-last contactor produces yet a more sweetened gas stream **CD(n-1)**. Each of these may be referred to as a “subsequent” sweetened gas stream.

[0196] A final sweetened gas stream **730(n)** is released by the final contactor **CDn**. The number of contacting devices (at least two) prior to the final contactor **CDn** is dictated primarily by the level of H₂S removal needed to meet the desired standard. In the system **705B** of **Figure 7**, the final sweetened gas stream **730(n)** still contains carbon dioxide. Therefore, the sweetened gas stream **730(n)** must be taken through the CFZ tower **100** of **Figure 6**. Sweetened gas stream **730(n)** is the same as line **678** from **Figure 6**.

[0197] In one aspect, a combination of a mixing device and a corresponding coalescing device is employed in each contactor. Thus, for example, the first **CD1** and second **CD2** contactors may utilize static mixers as their mixing devices, the third **CD3** and other **CD4** contactors may utilize eductors, and the **CDn-1** and **CDn** contactors may utilize centrifugal mixers. Each contactor has an associated coalescing device. In any embodiment, the gas streams **664**, **730(1)**, **730(2)**, . . . **730(n-1)** and the co-currently flowing liquid solvent streams flow through the contactors **CD1**, **CD2**, . . . **CDn** in the same direction. This allows a short time period for the treatment reactions to take place, perhaps even as short as 100 milliseconds or less. This can be advantageous for selective H₂S removal (relative to CO₂), as certain amines react more quickly with H₂S than with CO₂.

[0198] In addition to receiving a gas stream, each co-current contactor **CD1**, **CD2**, . . . **CD(n-1)**, **CDn** also receives a liquid solvent stream. In the system **705B**, the first contactor **CD1** receives a partially-regenerated solvent stream **720**. Thereafter, subsequent contactors **CD2**, **CD3**, **CD(n-1)**, **CDn** receive loaded solvent solutions released from the succeeding

respective contactor. Thus, the second contactor **CD2** receives partially-loaded solvent solution **740(3)** released from the third contactor **CD3**; the third contactor **CD3** receives a partially-loaded solvent solution **740(4)** released from the fourth contactor **CD4**; and the next-to-last contactor **CD(n-1)** receives a partially-loaded solvent solution **740(n)** from the final contactor **CDn**. Stated another way, the liquid solvent received into the second contactor **CD2** comprises the partially-loaded solvent solution **740(3)** released from the third contactor **CD3**; the liquid solvent received into the third contactor **CD3** comprises the partially-loaded solvent solution **740(4)** released from the fourth contactor **CD4**; and the liquid solvent received into a next-to-last contactor **CD(n-1)** comprises the partially-loaded solvent solution **740(n)** from the final contactor **CDn**. Thus, the partially-loaded solvent solutions are introduced into the contactors **CD1**, **CD2**, **CD3**, . . . **CDn** in a processing direction opposite that of the progressively sweetened gas streams **730(1)**, **730(2)**, **730(3)**, . . . **730(n-1)**.

[0199] The last separating contactor **CDn** also receives a liquid solvent. The liquid solvent is the regenerated solvent stream **760**. Regenerated solvent stream **760** is highly lean.

[0200] The chemical solvent system **705B** of **Figure 7B** is intended to be illustrative. Other arrangements for such a system that employs a plurality of co-current contacting devices as absorbers may be used. An example of such an additional system is described in the context of CO₂ removal in U.S. Serial No. 61/105,343, referenced above. **Figure 2B** and the corresponding portions of the Specification are incorporated herein by reference as well.

[0201] In the system **705B** of **Figure 7B**, both solvent solutions **740(1)** and **740(2)** undergo regeneration. Partially-regenerated solvent **780** comes out of the regenerating vessel **750**. The solvent **780** is placed under pressure through booster pump **782**. From there, the solvent **780** is cooled in heat exchanger **784** to become solvent stream **720**. The solvent **780** is further pressurized through booster pump **724** before being introduced into the first co-current contactor **CD1** as solvent stream **720**.

[0202] Referring again to **Figure 6**, the light gas stream **678** (which is also line **678** in **Figure 7A** and line **730(n)** in **Figure 7B**) exits the solvent system **605**, passes through a dehydrator, and passes through a chiller **626**. The chiller **626** chills the light gas stream **678** down to a temperature of about -30° F to -40° F. The chiller **626** may be, for example, an ethylene or a propane refrigerator.

[0203] The light gas stream **678** is next preferably moved through an expansion device **628**. The expansion device **628** may be, for example, a Joule-Thompson (“J-T”) valve. The expansion device **628** serves as an expander to obtain further cooling of the light gas stream **678**. The expansion device **628** further reduces the temperature of the light gas stream **678** down to, for example, about -70° F to -80° F. Preferably, at least partial liquefaction of the gas stream **678** is also accomplished. The cooled sour gas stream is indicated at line **611**.

[0204] The chilled sour gas in line **611** enters the cryogenic distillation tower **100**. The cryogenic distillation tower **100** may be any tower that operates to distill methane from acid gases through a process that intentionally freezes CO₂ particles. The cryogenic distillation tower may be, for example, the CFZ™ tower **100** of **Figure 1**. The chilled sour gas of line **611** enters the tower **100** at about 500 to 600 psig.

[0205] As explained in connection with **Figure 1**, acid gases are removed from the distillation tower **100** as a liquefied acid gas bottoms stream **642**. In this instance, the acid gas bottoms stream **642** comprises primarily carbon dioxide. The acid gas bottoms stream **642** contains very little hydrogen sulfide or other sulfurous components as such are captured by the sulfurous components removal system (which is the solvent system **605**) and delivered as the concentrated H₂S stream **655** for further processing. The H₂S may be converted into elemental sulfur using a sulfur recovery unit (not shown). The sulfur recovery unit may be a so-called Claus process. This enables more efficient sulfur recovery for large quantities of sulfur.

[0206] At least part of the bottoms stream **642** is sent through a reboiler **643**. From there, fluid containing methane is redirected back into the tower **100** as a gas stream **644**. The remaining fluid comprised primarily of carbon dioxide is released through CO₂ line **646**. The CO₂ in line **646** is in liquid form. The carbon dioxide in line **646** is preferably passed through a pressure booster **648** and then injected into a subsurface formation through one or more acid gas injection (AGI) wells as indicated by block **649**.

[0207] Methane is released from the distillation tower **100** as an overhead methane stream **112**. The overhead methane stream **112** will preferably comprise no more than about 2 mol. percent carbon dioxide. At this percentage, the overhead methane stream **112** may be used as fuel gas or may be sold into certain markets as natural gas. However, in accordance with certain methods herein, it is desirable that the overhead methane stream **112** undergo

further processing. More specifically, the overhead methane stream **112** is passed through an open loop refrigeration system.

[0208] First, the overhead methane stream **112** is passed through a cross exchanger **113**. The cross exchanger **113** serves to pre-cool the liquid reflux stream **18** that is reintroduced into the cryogenic distillation tower **100** after expansion through an expander device **19**. The overhead methane stream **112** is next sent through a compressor **114** to increase its pressure.

[0209] Next, the pressurized methane stream **112** is cooled. This may be done by, for example, passing the methane stream **112** through an aerial cooler **115**. A cool and pressurized methane stream **116** is produced. The methane stream **116** is preferably liquefied to generate a commercial product.

[0210] A part of the cooled and pressurized methane stream **116** leaving the cooler **115** is split into the reflux stream **18**. The reflux stream **18** is further cooled in the heat exchanger **113**, then expanded through the expander device **19** to ultimately generate the cold spray stream **21** of **Figure 1**. The cold spray stream **21** enters the distillation tower **100** where it is used as a cold liquid spray. The liquid spray, or reflux, reduces the temperature of the controlled freezing zone (shown at **108** of **Figure 1**) and helps to freeze out CO₂ and other acid gas particles from the dehydrated gas stream **624** as described above.

[0211] It will be appreciated that **Figure 6** represents a simplified schematic diagram intended to make clear only selected aspects of the gas processing system **600**. A gas processing system will usually include many additional components such as heaters, chillers, condensers, liquid pumps, gas compressors, blowers, other types of separation and/or fractionation equipment, valves, switches, controllers, along with pressure-, temperature-, level-, and flow-measuring devices.

[0212] Additional methods for removing sulfurous components from a raw gas stream are provided herein. One such method falls under the banner of “redox” processes. The term “redox” stands for a reduction-oxidation reaction. Reduction-oxidation describes chemical reactions in which atoms have their oxidation number or oxidation state changed. In the present redox process, an oxidized metal such as chelated iron reacts directly with H₂S to form elemental sulfur.

[0213] The oxidized metal is an aqueous chelated metal catalyst solution. In operation, the gas stream containing hydrogen sulfide is contacted with the chelated metal catalyst to effect absorption. Subsequent oxidation of the hydrogen sulfide to elemental sulfur and

concurrent reduction of the metal to a lower oxidation state takes place. The catalyst solution is then regenerated for reuse by contacting it with an oxygen-containing gas to oxidize the metal back to a higher oxidation state.

5 [0214] **Figure 8** is a schematic diagram showing a gas processing facility **800** for removing acid gases from a raw gas stream. In this arrangement, hydrogen sulfide is removed from a raw gas stream upstream of an acid gas removal system **650** by means of a redox process. The redox process is aqueous-based, meaning that dehydration of the raw gas stream need not take place before H₂S removal steps begin.

10 [0215] **Figure 8** shows the gas processing facility **800** receiving a production gas stream **812**. The production gas stream **812** originates from hydrocarbon production activities that take place in a reservoir development area, or “field” **810**. It is understood that the field **810** may represent any location where gaseous hydrocarbons are produced. The hydrocarbons will comprise methane as well as hydrogen sulfide. The hydrocarbons may also include ethane as well as carbon dioxide.

15 [0216] In the gas processing facility **800**, the gas stream **812** is fed into a sulfurous components removal system **850**. The sulfurous components removal system **850** uses a redox process. The sulfurous components removal system **850** first comprises contactor **820**. The contactor **820** defines a chamber **825** that receives raw hydrocarbon gases from the field **810**. Once in the chamber **825**, a chemical reaction takes place that separates hydrogen sulfide and other sulfurous components out of the raw gas stream **812**.

[0217] In order to produce the chemical reaction, the chamber **820** also receives a chelated oxidized metal. An example of such an oxidized metal is chelated iron. The chelated iron is in the form of a metal chelant solution. The metal chelant solution is delivered into the chamber **825** through line **842**.

25 [0218] Once inside the chamber **825**, the chelated metal solution reacts with hydrogen sulfide in the raw gas stream **812**. A reduction-oxidation reaction takes place. As a result, a chelated reduced metal mixture, along with elemental sulfur, is discharged through a bottom line **822**. At the same time, gases escape through overhead line **824**. The basic reaction is $S^{2-} + 2 Fe^{+++} \rightarrow S^0 + 2 Fe^{++}$.

30 [0219] The gases in line **824** comprise primarily methane and carbon dioxide. Trace amounts of ethane, nitrogen, or other components may also be present in line **824**. Together, the gases in line **824** represent a sour gas.

[0220] The illustrative sulfurous components removal system **850** also includes an oxidizer **830**. The oxidizer **830** defines a chamber **835** for oxidizing the reduced metal mixture. The oxidizer **830** receives the reduced metal mixture through line **822**. Pressure of the metal mixture in line **822** is controlled by valve **828**.

5 [0221] The oxidizer **830** also receives air. Air is introduced into the oxidizer **830** through line **834**. Pressure in line **834** is increased in order to circulate the air through the chamber **835** in the oxidizer **830** by air blower **838**. Once inside the chamber **835**, the air contacts the chelated metal mixture, causing the reduced metal mixture to be oxidized. The air is vented out of the oxidizer **830** through vent line **836**.

10 [0222] Oxidization produces an oxidized chelated metal mixture. The chelated mixture also contains sulfur in colloidal form. The chelated mixture with sulfur is dropped out of the oxidizer **830** through line **832**.

[0223] The illustrative sulfurous components removal system **850** also includes a separator **840**. The separator **840** of **Figure 8** is shown as a centrifuge. However, other types
15 of separators may be employed. The centrifuge **840** separates the aqueous chelant mixture with sulfur into two components. One component is elemental sulfur. The elemental sulfur is continuously removed from the process as a solid product with high purity. The contacting process is preferably limited to comparatively low pressures (300 psig or less), due to plugging of equipment with colloidal sulfur. The elemental sulfur may be stored or,
20 preferably, sold as a commercial product.

[0224] The elemental sulfur is dropped out at line 844. The sulfur is preferably directed to a sulfur handling unit (not shown). This leaves an aqueous metal chelant solution substantially devoid of elemental sulfur.

[0225] The aqueous metal catalyst solution in the removal system 850 is a regenerated
25 chelated iron. The chelated iron is redirected back into the contactor 820 by line 842. A pump 844 may be provided to increase pressure in line 842 and carry the chelant mixture to the contacting vessel 825. In this way, The chelated iron (or other oxidized metal) may be reclaimed and reused.

[0226] Referring again to the gas line 824, sour gas in gas line 824 is taken to a
30 dehydration vessel 860. Because the redox process uses an aqueous-based material for separating H₂S from the raw gas stream 812, subsequent dehydration of the gas in line 824 is required prior to cryogenic acid gas removal. As a result of passing the sour gas from gas

line 824 through the dehydration vessel 860, an aqueous stream 862 is generated. The aqueous stream 862 may be sent to a water treatment facility. Alternatively, the aqueous stream 862 may be re-injected into a subsurface formation, such as subsurface formation 630 from Figure 6. Alternatively still, the removed aqueous stream 862 may be treated to meet
5 environmental standards and then released into the local watershed (not shown) as treated water.

[0227] Also, as a result of passing the sour gas from line 824 through the dehydration vessel 860, a substantially dehydrated gas stream 864 is produced. The dehydrated gas stream 864 comprises methane, and may also contain trace amounts of nitrogen, helium and
10 other inert gases. In connection with the present systems and methods, the dehydrated gas stream 864 also includes carbon dioxide.

[0228] The dehydrated gas stream 864 exits the dehydration vessel 860 and passes through a chiller 626. The chiller 626 chills the dehydrated gas stream 864 down to a temperature of about -30° F to -40° F. The chiller 626 may be, for example, an ethylene or a
15 propane refrigerator. A chilled light gas stream 678 is thus generated.

[0229] The light gas stream 678 is next preferably moved through an expansion device 628. The expansion device 628 may be, for example, a Joule-Thompson (“J-T”) valve. The expansion device 628 serves as an expander to obtain further cooling of the light gas stream 678. The expansion device 628 further reduces the temperature of the light gas stream 678
20 down to, for example, about -70° F to -80° F. Preferably, at least partial liquefaction of the gas stream 678 is also accomplished. The cooled sour gas stream is indicated at line 611.

[0230] The cooled sour gas in line 611 is directed into a distillation tower. The distillation tower may be CFZ tower 100 from Figures 1 and 6, for example. The sour gas from line 611 is then processed through an acid gas removal system. The acid gas removal
25 system may be, for example, in accordance with acid gas removal system 650 of Figure 6.

[0231] Another means for removing sulfurous components from a raw gas stream is through the use of scavengers in a scavenger bed. The use of scavengers is known in the gas processing industry as a way of removing H₂S and mercaptans from a gas stream. The scavengers may be solids, they may be in liquid form, or they may be a catalyst solution.

30 [0232] Scavengers convert sulfhydryl- and other sulfur-containing compounds into harmless compounds such as metal sulfides. The compound may be disposed of safely and in an environmentally sound manner. Scavengers have particular utility when the H₂S composition in a raw gas stream is low such that conventional amine treating is not

economically feasible. An example is where the H₂S composition is less than about 300 ppm.

[0233] An example of known liquid-based scavenger is triazine. A more specific example is an aqueous formulation of 1,3,5 tri-(2-hydroxyethyl)-hexahydro-S-triazine.

5 Another example of a liquid-based scavenger is a nitrite solution.

[0234] Examples of solid scavengers are iron oxide (FeO, Fe₂O₃, or Fe₃O₄) and zinc oxide (ZnO). Solid scavengers generally are non-regenerable. Once a non-regenerable scavenger bed is spent, it must be replaced. Iron oxide generally requires some moisture to be effective, while zinc oxide does not. Thus, if the sour gas stream has already been
10 dehydrated, the use of ZnO would be advantageous in that additional dehydration would not necessarily be required upstream of the CO₂-removal process. However, water may be generated from the oxidation process. Thus, depending on the initial level of H₂S, subsequent dehydration may be required.

[0235] Hydrogen sulfide scavenging agents are most commonly applied through one of
15 three methods. First, a batch application of liquid scavenging agents may be used in a sparged tower contactor. Second, a batch application of solid scavenging agents may be applied in a fixed-bed contactor. Third, a continuous direct injection of liquid scavenging agents into a vessel may be employed. This is the most common application.

[0236] Conventional direct-injection H₂S scavenging uses a pipeline as a contactor. In
20 this application, a liquid H₂S-scavenging agent such as triazine is injected into the gas stream. H₂S is absorbed into the scavenging solution. The H₂S is reacted to form byproducts which are subsequently removed from the raw gas stream and discarded. An alternative method for direct-injection of H₂S scavenging involves the forcing of a liquid jet of the scavenging agent through a small opening under high pressure. Typically, an atomizing nozzle is used to cause
25 the liquid scavenging agent to be atomized into very small droplets. For many applications, a direct-injection approach has the potential for the lowest overall costs because of its low capital cost relative to batch applications.

[0237] Figure 9 is a schematic diagram showing a gas processing facility 900 for removing acid gases from a gas stream in accordance with the present invention, in one
30 embodiment. In this arrangement, hydrogen sulfide is removed from a raw gas stream 912 upstream of an acid gas removal system 950 by means of a scavenger.

[0238] Figure 9 shows the gas processing facility 900 receiving a production gas stream 912. The production gas stream 912 originates from hydrocarbon production activities that

take place in a reservoir development area, or “field” 910. It is understood that the field 910 may represent any location where gaseous hydrocarbons are produced. The hydrocarbons will comprise methane as well as hydrogen sulfide. The hydrocarbons may also include ethane as well as carbon dioxide.

5 [0239] In the gas processing facility 900, the production gas stream 912 is fed into a sulfurous components removal system 950. The sulfurous components removal system 950 uses an H₂S scavenger. Any of the above-described scavenging methods may be employed. The illustrative sulfurous components removal system 950 uses the third method mentioned above, that is, a liquid scavenger with continuous injection into a separating vessel 920.

10 [0240] In order to remove sulfurous components from the raw gas stream 912, the raw gas stream 912 is directed into a pipeline 922. At the same time, a liquid scavenger such as triazine is introduced into the pipeline 922 through scavenger line 944. The triazine is injected through an atomizing nozzle 923, and then mixed with the raw gas stream 912 in a static mixer 925. From there, the contacted raw gas stream 912 enters the separating vessel
15 920.

[0241] The separating vessel 920 defines a chamber 926. Liquids settle into the bottom of the chamber 926, while gaseous components exit at the top of the chamber 926. The liquids exit through liquid line 927. The liquids comprise spent scavenger material. A portion of the liquids from line 927 are removed as effluent waste. Waste line 942 directs the
20 effluent waste to a holding tank (not shown) or other waste holding area. The waste may be transported away by truck or by disposal line. The remaining portion of the liquids from line 927 may be redirected back into the scavenger line 944 for contacting the raw gas stream 912 if the scavenger is not fully spent.

[0242] The sulfurous components removal system 950 also includes a scavenger vessel
25 930. The scavenger vessel 930 holds the liquid scavenging agent. The operator passes the liquid scavenging agent from the scavenger vessel 930 into the scavenger line 944 as needed. A pump 946 is provided for increasing pressure for the injection of the liquid scavenging agent into the pipeline 922.

[0243] Referring again to the separating vessel 920, the separating vessel 920 may
30 include a mist eliminator 924. The mist eliminator 924 helps to prevent liquid particles from escaping out of the top of the separating vessel 920 with the gaseous components. This phenomenon is called entrainment. The mist eliminator 924 is akin to a mesh or a membrane that creates a tortuous path for vapor as it travels upward in the separating vessel 920. Mist

eliminators are known. One source of mist eliminators is Separation Products, Inc. of Alvin, Texas. Separation Products, Inc. manufactures mist eliminators under the trade name Amistco™.

5 [0244] The gaseous components leave the separating vessel 920 through overhead gas line 945. The gaseous components represent primarily methane and carbon dioxide. Trace elements of ethane, nitrogen, helium and aromatics may also be present. The gas in line 945 may be referred to as a sour gas. The sour gas in gas line 945 is taken to a dehydration vessel 960.

10 [0245] Because the scavenger process uses an aqueous-based material for separating H₂S from the raw gas stream 912, dehydration of the gas in line 945 is required prior to cryogenic carbon dioxide removal. As a result of passing the sour gas from gas line 945 through the dehydration vessel 960, an aqueous stream 962 is generated. The aqueous stream 962 may be sent to a water treatment facility. Alternatively, the aqueous stream 962 may be re-injected into a subsurface formation, such as subsurface formation 630 from Figure 6. Alternatively
15 still, the removed aqueous stream 962 may be treated to meet environmental standards and then released into the local watershed (not shown) as treated water.

[0246] Also, as a result of passing the sour gas from line 945 through the dehydration vessel 960, a substantially dehydrated gas stream 964 is produced. The dehydrated gas stream 964 is passed through a chiller 626. The chiller 626 chills the dehydrated gas stream
20 964 down to a temperature of about -30° F to -40° F. The chiller 626 may be, for example, an ethylene or a propane refrigerator. A chilled light gas stream 678 is thus generated.

[0247] The light gas stream 678 next preferably moves through an expansion device 628. The expansion device 628 may be, for example, a Joule-Thompson (“J-T”) valve. The expansion device 628 serves as an expander to obtain further cooling of the light gas stream
25 678. The expansion device 628 further reduces the temperature of the light gas stream 678 down to, for example, about -70° F to -80° F. Preferably, at least partial liquefaction of the gas stream 678 is also accomplished. The cooled sour gas stream is indicated at line 611.

[0248] The cooled sour gas in line 611 is directed into a distillation tower. The distillation tower may be CFZ tower 100 from Figures 1 and 6, for example. The cooled gas stream is then processed through an acid gas removal system. The acid gas removal system
30 may be, for example, in accordance with acid gas removal system 650 of Figure 6.

[0249] Yet another means proposed herein for the removal of organosulfur compounds having a sulfhydryl (--SH) group is through what is known as a CrystaSulf process. The

CrystaSulf process was developed by CrystaTech, Inc. of Austin, Texas. The CrystaSulf process uses a modified liquid-phase Claus reaction process to remove H₂S from a raw gas stream.

[0250] A "Claus process" is a process that is sometimes used by the natural gas and refinery industries to recover elemental sulfur from hydrogen sulfide-containing gas streams. Briefly, the Claus process for producing elemental sulfur comprises two primary sections. The first section is a thermal section wherein part of the H₂S is combusted to SO₂, and the formed SO₂ reacts with the remaining H₂S to generate elemental sulfur at approximately 1,800° to 2,200° F. No catalyst is present in the thermal section. The second section is a catalytic section wherein elemental sulfur is produced at temperatures between 400° to 650° F over a suitable catalyst (such as alumina). The reaction to produce elemental sulfur is an equilibrium reaction; hence, there are several stages in the Claus process where separations are made in an effort to enhance the overall conversion of H₂S to elemental sulfur. Each stage involves heating, reacting, cooling and separation.

[0251] The term "CrystaSulf" refers not only to a process, but also to a solvent used in the process. CrystaSulf[®] is a nonaqueous, physical solvent that dissolves hydrogen sulfide and sulfur dioxide, so that they can react directly into elemental sulfur. The CrystaSulf[®] solvent is sometimes called a liquor, or a scrubbing liquor. In the CrystaSulf process, hydrogen sulfide is removed from a gas stream using the nonaqueous scrubbing liquor. The scrubbing liquor can be an organic solvent for elemental sulfur such as a phenylxylyl ethane. Generally, the nonaqueous solvent may be selected from the group consisting of alkyl-substituted naphthalenes, diaryl alkanes including phenylxylyl ethanes such as phenyl-oxylylethane, phenyl tolyl ethanes, phenyl naphthyl ethanes, phenyl aryl alkanes, dibenzyl ether, diphenyl ether, partially hydrogenated terphenyls, partially hydrogenated diphenyl ethanes, partially hydrogenated naphthalenes, and mixtures thereof.

[0252] Typically, the CrystaSulf[®] solvent employs SO₂ as an oxidant. This allows the Claus reaction ($2\text{H}_2\text{S} + \text{SO}_2 \rightarrow 3\text{S} + 2\text{H}_2\text{O}$) to take place in the solvent phase. Stated another way, sulfur dioxide is added to the solvent solution to obtain better H₂S removal.

[0253] The CrystaSulf process is described in U.S. Patent No. 6,416,729. The '729 patent is entitled "Process for Removing Hydrogen Sulfide from Gas Streams Which Include or are Supplemented with Sulfur Dioxide." The '729 patent is incorporated herein by reference in its entirety. Additional embodiments for the CrystaSulf process are disclosed in U.S. Patent No. 6,818,194, entitled "Process for Removing Hydrogen Sulfide From Gas

Streams Which Include or Are Supplemented with Sulfur Dioxide, by Scrubbing with a Nonaqueous Sorbent.” The ‘194 patent is also incorporated herein by reference.

[0254] Figure 10 is a schematic diagram showing a gas processing facility 1000 for removing acid gases from a gas stream in another embodiment. In this arrangement, hydrogen sulfide is removed from a raw gas stream 1012 upstream of an acid gas removal system 650 by means of a CrystaSulf process. The CrystaSulf process is part of a sulfurous components removal system 1050 for removing the hydrogen sulfide.

[0255] Figure 10 shows the gas processing facility 1000 receiving a production gas stream 1012. The production gas stream 1012 originates from hydrocarbon production activities that take place in a reservoir development area, or “field” 1010. The field 1010 is synonymous with the fields 810 and 910 described above. Hydrocarbons are produced from the field 1010. The hydrocarbons will comprise methane along with hydrogen sulfide. The hydrocarbons may also include ethane as well as carbon dioxide.

[0256] In the gas processing facility 1000, the production gas stream 1012 is fed into the sulfurous components removal system 1050. The sulfurous components removal system 1050 uses the CrystaSulf process described above. In order to remove sulfurous components from the raw gas stream 1012 in accordance with the CrystaSulf process, the raw gas stream 1012 is directed into an absorber 1020. At the same time, liquid SO₂ is introduced into the absorber 1020 through line 1084. The liquefied sulfur dioxide is added as an oxidizing gas.

[0257] The liquid SO₂ is originally maintained in a storage vessel 1080. SO₂ line 1082 carries liquid SO₂ from the storage vessel 1080 to line 1084, as needed. A pump 1076 is provided along line 1082 for increasing pressure so as to move the liquid SO₂ into the absorber 1020.

[0258] The absorber 1020 defines a chamber 1025. In the absorber 1020, the raw gas stream 1012 is contacted with the liquid solvent containing SO₂ from line 1084. Liquids settle into the bottom of the chamber 1025, while gaseous components exit at the top of the chamber 1025. The liquids, referred to as a sorbent, exit through liquid line 1022. The sorbent generally comprise a solution of sulfur and water, along with trace elements of methane plus residual hydrogen sulfide and/or sulfur dioxide.

[0259] The liquids are directed through line 1022 into a flask 1030. The flask 1030 serves to flash out water and any entrained hydrocarbon gases from solvent. The sulfur-containing solution exits the flask through bottom stream **1036**. At the same time, hydrocarbon gases and traces of water vapor exit an overhead line **1032**.

[0260] The overhead line 1032 is carried through a compressor 1034. Boosting the pressure of overhead line 1032 helps break water out of the hydrocarbon gases. The hydrocarbon gases are then directed into a separating vessel 1040. The separating vessel 1040 is typically a gravitational separator, though a hydrocyclone or Vortistep separator may also be used. Water drops out of the separating vessel 1040 at line 1044. The water in line 5 1044 is preferably directed to a treatment facility (not shown).

[0261] Hydrocarbon gases are released from the separating vessel 1040 through line 1042. The hydrocarbon gases in line 1042 are merged with the raw gas stream 1012. From there, the hydrocarbon gases re-enter the absorber 1020.

10 [0262] Referring again to the flask 1030, as noted, the flask releases a sulfur-containing solution through bottom stream 1036. The sulfur-containing solution is moved into a cooling loop 1038. The sulfur-containing solution is merged with a portion of a clear liquor from line 1058. The clear liquor may include, for example, additional physical solvent.

[0263] Pressure in the cooling loop 1038 is increased as the sulfur-containing solution is 15 moved through a centrifugal pump 1052. From there, the sulfur-containing solution is chilled in a PTFE heat exchanger 1054. As the sulfur-containing solution passes through the heat exchanger 1054, it is cooled below the saturation temperature with respect to dissolved sulfur. The sulfur-containing solution becomes supersaturated with respect to the dissolved sulfur, which thus becomes crystallized.

20 [0264] The chilled and crystallized sulfur-containing solution enters a crystallizer 1055. Specifically, the sulfur-containing solution from line 1038 is directed into the bottom of the crystallizer 1055. The chilled sulfur-containing solution comes into contact with sulfur crystals present in a settling zone 1059 within the crystallizer 1055. The crystals act to seed the supersaturated sulfur solution to effect precipitation of the dissolved sulfur. This creates a 25 sulfur slurry.

[0265] The sulfur slurry exits the crystallizer 1055 through sulfur slurry line 1056. The sulfur slurry in line 1056 is delivered to a filter 1060. The filter 1060 separates the sulfur slurry into pure solid sulfur and a clear liquor. Removal of the solid sulfur is represented by line 1062. The clear liquor is released as a filtrate through line 1064 and recycled back to the 30 crystallizer 1055. A pump 1066 is preferably provided for moving the clear liquor back into the crystallizer 1055.

[0266] The clear liquor rises to the top of the crystallizer. A portion of the clear liquor is directed from the crystallizer 1055 through line 1058. The clear liquor in line 1058 is merged with the sulfur solution 1036 from the flask to form cooling loop 1038, as discussed above. A separate portion of the clear liquor is extracted from the top of the crystallizer 1055
5 through line 1072. The extracted liquor in line 1072 is heated through a heat exchanger 1074. The heated liquor is merged with sulfur dioxide from line 1082. The heated liquor 1074 is taken through the booster pump 1076, and then redirected into the chamber 1025 of the absorber 1020.

[0267] It is understood that the CrystaSulf process described in connection with the
10 sulfurous components removal system 1000 is merely illustrative. Other CrystaSulf processes such as those described in incorporated U.S. Patent No. 6,416,729 and U.S. Patent No. 6,818,194 may be used. Regardless of the process, an overhead gas stream 1045 is generated from the absorber 1020.

[0268] The overhead gas stream 1045 contains primarily methane and carbon dioxide.
15 Trace elements of ethane, nitrogen, helium and aromatics may also be present. Sulfurous components have been extracted and carried away through line 1062. The overhead gas stream 1045 may be referred to as sour gas. The sour gas in gas stream 1045 is preferably taken to a dehydration vessel 1060. However, because the CrystaSulf process is non-aqueous, dehydration may take place before the raw gas stream 1012 enters the sulfurous
20 components removal system 1050.

[0269] The overhead gas stream 1045 is passed through a chiller 626. The chiller 626 chills the gas stream 1045 down to a temperature of about -30° F to -40° F. The chiller 626 may be, for example, an ethylene or a propane refrigerator. A chilled light gas stream 678 is thus generated.

[0270] The light gas stream 678 next is preferably moved through an expansion device
25 628. The expansion device 628 may be, for example, a Joule-Thompson ("J-T") valve or other device as described in connection with Figure 6. The expansion device 628 further reduces the temperature of the light gas stream 678 down to, for example, about -70° F to -80° F. Preferably, at least partial liquefaction of the gas stream 678 is also accomplished.
30 The cooled gas stream is moved through line 611.

[0271] The cooled sour gas in line 611 is directed into a distillation tower. The distillation tower may be CFZ tower 100 from Figures 1 and 6, for example. The cooled sour

gas in line 611 is then processed through an acid gas removal system. The acid gas removal system may be, for example, in accordance with acid gas removal system 650 of Figure 6 used to remove carbon dioxide.

[0272] Two additional methods that may be used for the removal of at least modest levels of hydrogen sulfide upstream of a cryogenic distillation tower involve the use of an adsorbent bed. One method employs thermal swing adsorption, while the other utilizes pressure swing adsorption. The adsorbent beds are molecular sieves. In each case, the molecular sieves are regenerated.

[0273] Molecular sieves are often used for dehydration, but can also be used for H₂S and mercaptan removal. Oftentimes, these services are combined in a single packed bed, with a layer of 4A molecular sieve material on top for dehydration, and a layer of 13X molecular sieve material on bottom for H₂S and mercaptan removal. Thus, a raw gas stream is both dried and de-sulfurized.

[0274] Figure 11 presents a schematic diagram showing a gas processing facility 1100 for removing acid gases from a gas stream, in another embodiment. In this arrangement, hydrogen sulfide is removed from a raw gas stream 624 upstream of an acid gas removal system 650 by means of a thermal swing adsorption system 1150.

[0275] The gas processing facility 1100 generally operates in accordance with gas processing facility 600 of Figure 6. In this respect, a dehydrated gas stream 624 is delivered to a sulfurous components removal system. From there, sour gas comprised primarily of methane and carbon dioxide is chilled and delivered to an acid gas removal system 650 through line 611. However, instead of using a solvent system 605 along with an absorber as the sulfurous components removal system, a thermal swing adsorption system 1150 is used. The thermal swing adsorption system 1150 provides at least partial separation of hydrogen sulfide from the dehydrated gas stream 624.

[0276] The thermal swing adsorption system 1150 uses an adsorbent bed 1110 to selectively adsorb hydrogen sulfide and other sulfurous components, while passing a light gas stream comprised of methane and carbon dioxide. The light gas stream is shown being released at line 1112. The light gas stream 1112 is delivered to a distillation tower, such as tower 100 of Figure 1 as a sour gas stream for the separation of carbon dioxide from the methane.

[0277] It is preferred that pre-cooling be provided to the light gas stream 1112 before entrance into the cryogenic distillation tower 100. In the illustrative gas processing facility 1100, the light gas stream 1112 is passed through a refrigeration unit 626, and then through an expansion device 628. The expansion device 628 may be, for example, a Joule-Thompson (“J-T”) valve. Preferably, at least partial liquefaction of the light gas stream 1112 is accomplished in connection with the cooling. A cooled sour gas stream is generated which is directed to the acid gas removal system 650 through line 611.

[0278] Referring again to the thermal swing adsorption system 1150, the adsorbent bed 1110 in the thermal swing adsorption system 1150 is preferably a molecular sieve fabricated from zeolite. However, other adsorbent beds such as a bed fabricated from silica gel may be employed. Those of ordinary skill in the art of hydrocarbon gas separation will understand that the selection of the adsorbent bed will typically depend on the composition of the contaminant being removed. In this case, the contaminant is principally hydrogen sulfide.

[0279] In operation, the adsorbent bed 1110 will reside in a pressurized chamber. The adsorbent bed 1110 receives the dehydrated gas stream 624 and adsorbs hydrogen sulfide and other sulfurous components along with a certain amount of carbon dioxide. The adsorbent bed 1110 in the adsorption system 1150 will be replaced with a regenerated bed once the bed becomes substantially saturated with H₂S. The H₂S will be released from the bed 1110 in response to heating the bed using a dry heated gas. Suitable gases include a portion of the overhead methane stream 112, heated nitrogen, or a fuel gas otherwise available.

[0280] Block 1140 depicts a regeneration chamber for an adsorbent bed. The regeneration chamber 1140 receives a dry, heated gas 1132. In the arrangement of Figure 11, the dry gas 1132 is received from the overhead methane stream 112. The overhead methane stream 112 comprises primarily methane, but may also include trace amounts of nitrogen and helium. The overhead methane stream 112 may be compressed to raise the pressure of the gas in the regeneration chamber. A pressure booster is shown at 1130. However, regeneration primarily takes place through increased temperature, though it is generally enhanced by lower pressures.

[0281] Ten to fifteen percent of the overhead methane stream 112 may be required for adequate regeneration. The regeneration chamber 1140 releases a heated, dry fluid stream 1142. The dry fluid stream 1142 is directed to the solid sorbent bed 1110 and acts as a

regeneration stream. The dry fluid stream 1142 is comprised primarily of methane, but also contains some CO₂.

[0282] For a thermal swing regeneration cycle, at least three adsorbent beds are preferably employed: a first bed is used for adsorption as shown at 1110; a second bed
5 undergoes regeneration in the regeneration chamber 1140; and a third bed has already been regenerated and is in reserve for use in the adsorption system 1150 when the first bed 1110 becomes substantially saturated. Thus, a minimum of three beds is used in parallel for a more efficient operation. These beds may be packed, for example, with silica gel.

[0283] As seen in Figure 11, a concentrated H₂S gas stream is released from the
10 adsorption system 1110 through line 1114. The concentrated hydrogen sulfide stream 1114 also acts as a regeneration stream. The regeneration stream 1114 comprises primarily CH₄ and H₂S, but will most likely also contain trace amounts of carbon dioxide and possibly some heavy hydrocarbons. In one aspect, the regeneration stream 1114 is cooled using a refrigeration unit 1116. This causes at least a partial liquefaction of the regeneration stream
15 1114. The regeneration stream 1114 is then introduced into a separator 1120. The separator 1120 is preferably a gravity separator that separates the water in the regeneration stream 1114 from the light gases. The light gases generally comprise methane, hydrogen sulfide, and carbon dioxide.

[0284] Light gases are released from the top of the separator 1120 (shown schematically
20 at line 1122). The light gases released from the separator 1120 in line 1122 are returned to the dehydrated gas stream 624. At the same time, water, heavy hydrocarbons (primarily ethane) and dissolved hydrogen sulfide are released from the bottom of the separator 1120 (shown schematically at line 1124). In some implementations, the recycle gas in line 1122 may need treatment for H₂S to ensure that it is not recycled through the system.

[0285] It is noted that the gas processing facility 1100 optionally may not include a
25 dehydration unit 620. Water will be dropped out of the solid sorbent bed 1110 with the regeneration stream 1114 and will not pass to the sour gas stream of line 611. The water will further be dropped out of the separator 1120 with the hydrogen sulfide in line 1124. Separation of water from sulfurous compounds may then be accomplished by using, for
30 example, a sour water stripper or other separator (not shown).

[0286] In one application, spent gas from the regeneration gas heater 1140 may be burned to drive a turbine (not shown). The turbine, in turn, may drive an open loop compressor

(such as compressor 176 of Figure 1). The regeneration gas heater 1140 may be further integrated into the acid gas removal process by taking waste heat from such a turbine and using it to pre-heat the regeneration gas (such as in line 1132) for the hydrogen sulfide recovery process. Similarly, heat from the overhead compressor 114 may be used to pre-heat the regeneration gas used for the hydrogen sulfide recovery process.

[0287] It is observed here that the regeneration gas contains the H₂S that has been desorbed from the solid bed 1110. That gas may be contacted with a solvent to remove the H₂S and recover the methane and any other hydrocarbons. In this way, the BTU value of the gas can be salvaged.

10 [0288] As noted, pressure swing adsorption may also be used to remove hydrogen sulfide and other sulfurous components upstream of an acid gas removal facility. Pressure swing adsorption, or "PSA," refers generally to a process wherein a contaminant is adsorbed onto a solid sorbent bed. After saturation, the solid sorbent is regenerated by lowering its pressure. Reducing the pressure causes the contaminant to be released as a low-pressure stream.

15 [0289] Figure 12 provides a schematic diagram of a gas processing facility 1200 that uses pressure swing adsorption for the removal of hydrogen sulfide. The gas processing facility 1200 generally operates in accordance with gas processing facility 600 of Figure 6. In this respect, a dehydrated gas stream 624 is chilled and then delivered to an acid gas removal system 650 through sour gas line 611. However, instead of using a physical solvent contacting system 605 along with contacting tower 670 to remove hydrogen sulfide, a pressure swing adsorption system 1250 is used. The pressure swing adsorption system 1250 provides at least partial separation of hydrogen sulfide from the raw gas stream 624.

25 [0290] As with the thermal swing adsorption system 1150, the pressure swing adsorption system 1250 uses an adsorbent bed 1210 to selectively adsorb H₂S while releasing methane gas. The adsorbent bed 1210 is preferably a molecular sieve fabricated from zeolite. However, other adsorbent beds such as a bed fabricated from silica gel may be employed. Those of ordinary skill in the art of hydrocarbon gas separation will again understand that the selection of the adsorbent bed will typically depend on the composition of the raw gas stream 624.

30 [0291] As seen in Figure 12, the adsorption system 1250 releases methane gas through a light gas stream 1212. The light gas stream 1212 is carried through a refrigeration unit 626 and then, preferably, through a Joules-Thompson valve 628 before entry into the cryogenic

distillation tower 100. At the same time, a concentrated hydrogen sulfide stream is released from the adsorbent bed 1210 through line 1214.

[0292] In operation, the adsorbent bed 1210 in the pressure swing adsorption system 1250 resides in a pressurized chamber. The adsorbent bed 1210 receives the dehydrated gas stream 624 and adsorbs H₂S along with any remaining water and any heavy hydrocarbons. Trace amounts of carbon dioxide may also be adsorbed. The adsorbent bed 1210 will be replaced once the bed 1210 becomes saturated with hydrogen sulfide and other sulfurous components. The H₂S (and heavy hydrocarbons, if any) will be released from the bed in response to reducing pressure in the pressurized chamber. A concentrated hydrogen sulfide stream 1214 is then released.

[0293] In most cases, reducing the pressure in the pressurized chamber down to ambient pressure will cause a majority of the hydrogen sulfide and other contaminants in the concentrated hydrogen sulfide stream 1214 to be released from the adsorbent bed 1210. In some extreme cases however, the pressure swing adsorption system 1250 may be aided by the use of a vacuum chamber to apply sub-ambient pressure to the concentrated hydrogen sulfide stream 1214. This is indicated at block 1220. In the presence of lower pressure, sulfurous components and heavy hydrocarbons will desorb from the solid matrix making up the adsorbent bed 1210.

[0294] A mixture of water, heavy hydrocarbons and hydrogen sulfide will exit the vacuum chamber 1220 through line 1222. The mixture will enter a separator 1230. The separator 1230 is preferably a gravity separator that separates heavy hydrocarbons and water from hydrogen sulfide. The liquid components are released from the bottom (shown schematically at line 1234). Any heavy hydrocarbons in line 1234 may be sent for commercial sale after treatment for dissolved H₂S. Hydrogen sulfide in gaseous form is released from the top of the separator 1230 (shown schematically at line 1232). The H₂S in line 1232 is sent to a sulfur recovery unit (not shown) or injected into a subsurface formation as part of acid gas injection.

[0295] The pressure swing adsorption system 1250 may rely on a plurality of beds in parallel. A first bed 1210 is used for adsorption. This is known as a service bed. A second bed (not shown) undergoes regeneration through pressure reduction. A third bed has already been regenerated and is in reserve for use in the adsorption system 1250 when the first bed 1210 becomes substantially saturated. Thus, a minimum of three beds may be used in

parallel for a more efficient operation. These beds may be packed, for example, with activated carbons or molecular sieves.

[0296] The pressure swing adsorption system 1250 may be a rapid cycle pressure swing adsorption system. In the so-called "rapid cycle" processes, cycle times can be as small as a few seconds. A rapid cycle PSA ("RCPSA") unit would be particularly advantageous, as it is quite compact relative to a normal PSA device. Note that pretreatment may be required for the inlet gas. Alternatively, a sacrificial layer of material at the top of the packed bed may be used to preserve the active material.

[0297] In one aspect, a combination of thermal swing regeneration and pressure swing regeneration may be employed.

[0298] Another method proposed herein for removing hydrogen sulfide upstream of an acid gas removal system is a process called adsorptive kinetic separations, or AKS. AKS employs a relatively new class of solid adsorbents that relies upon the rate at which certain species are adsorbed onto structured adsorbents relative to other species. This is in contrast to traditional equilibrium-controlled swing adsorption processes wherein the selectivity is primarily imparted by the equilibrium adsorption properties of the solid adsorbent. In the latter case, the competitive adsorption isotherm of the light product in the micropores or free volume of the adsorbent is not favored.

[0299] In a kinetically controlled swing adsorption process, selectivity is imparted primarily by the diffusional properties of the adsorbent and by the transport diffusion coefficient in the micropores. The adsorbent has a "kinetic selectivity" for one or more gas components. As used herein, the term "kinetic selectivity" is defined as the ratio of single component diffusion coefficients, D (in m^2/sec), for two different species. These single component diffusion coefficients are also known as the Stefan-Maxwell transport diffusion coefficients that are measured for a given adsorbent for a given pure gas component. Therefore, for example, the kinetic selectivity for a particular adsorbent for component A with respect to component B would be equal to D_A/D_B . The single component diffusion coefficients for a material can be determined by tests well known in the adsorptive materials art.

[0300] The preferred way to measure the kinetic diffusion coefficient is with a frequency response technique described by Reyes, et al. in "Frequency Modulation Methods for Diffusion and Adsorption Measurements in Porous Solids", J. Phys. Chem. B. 101, pp. 614-

622 (1997). In a kinetically controlled separation, it is preferred that kinetic selectivity (i.e., D_A/D_B) of the selected adsorbent for the first component (e.g., Component A) with respect to the second component (e.g., Component B) be greater than 5, more preferably greater than 20, and even more preferably greater than 50.

5 [0301] It is preferred that the adsorbent be a zeolite material. Non-limiting examples of zeolites having appropriate pore sizes for the removal of heavy hydrocarbons include MFI, faujasite, MCM-41 and Beta. It is preferred that the Si/Al ratio of zeolites utilized in an embodiment of a process of the present invention for heavy hydrocarbon removal be from about 20 to about 1,000, preferably from about 200 to about 1,000 in order to prevent
10 excessive fouling of the adsorbent. Additional technical information about the use of adsorptive kinetic separation for the separation of hydrocarbon gas components is U.S. Pat. Publ. No. 2008/0282884, the entire disclosure of which is incorporated herein by reference.

[0302] Figure 13 is a schematic diagram showing a gas processing facility 1300 of the present invention, in another embodiment. In this arrangement, hydrogen sulfide is removed
15 from a gas stream upstream of an acid gas removal system 650 by means of an adsorptive bed 1310 that utilizes adsorptive kinetic separation.

[0303] The gas processing facility 1300 operates generally in accordance with the gas processing facility 600 of Figure 6A. In this respect, a dehydrated gas stream 624 is chilled in a preliminary refrigeration unit 625 and then delivered to an acid gas removal system 650
20 through a sour gas stream in line 611. However, instead of using a physical solvent contacting system 605 along with contacting tower 670 upstream of the acid gas removal system 650 to remove hydrogen sulfide, an AKS solid adsorbent bed 1310 is used. The adsorbent bed 1310 preferentially adsorbs hydrogen sulfide.

[0304] In the current adsorptive kinetic separation application, the hydrogen sulfide
25 components will be retained by the adsorbent bed 1310. This means that H_2S will be recovered at a lower pressure. The adsorbent bed 1310 may be used in conjunction with pressure swing adsorption or rapid cycle pressure swing adsorption. Upon pressure reduction, a natural gas liquids stream 1314 is released from the solid adsorbent bed at low pressure. The natural gas liquids stream 1314 contains most of the sulfurous components
30 from the dehydrated gas stream 624, and may also contain heavy hydrocarbons and trace amounts of carbon dioxide.

[0305] To separate hydrogen sulfide and carbon dioxide from the heavy hydrocarbons, an additional distillation column is required. A distilling vessel is shown at 1320. The distilling vessel 1320 may be, for example, a trayed or packed column used as a contaminant clean-up system. Hydrogen sulfide and carbon dioxide are released through overhead line 1324. Line 1324 is preferably merged with acid gas line 646 for acid gas injection into reservoir 1349. Sour heavy hydrocarbons and most water molecules exit the distilling vessel 1320 through a bottom line 1322. The heavy hydrocarbons may be in the form of natural gas liquids, that is, ethane and, possibly, propane. The natural gas liquids are treated for H₂S removal and are captured for sale.

10 [0306] It is noted that the adsorptive kinetic separations process of system 1300 may be more beneficial for recovering hydrogen sulfide and heavy hydrocarbons from natural gas streams produced under a large excess of pressure. In this situation, the sour gas in line 611 has adequate pressure to be processed by the cryogenic distillation tower 100. An example of excess pressure would be pressure greater than 400 psig.

15 [0307] The adsorbent bed 1310 releases a light gas stream 1312. The gases in stream 1312 are comprised primarily of methane and carbon dioxide. It is preferred that cooling be provided to the light gases in stream 1312 before entrance into the cryogenic distillation tower 100. In the illustrative gas processing facility 1300, the light gases in stream 1312 are passed through a refrigeration unit 626, and then through an expansion device 628. A cooled sour gas stream is generated in line 611 which is directed to the acid gas removal system 650.

[0308] In another general approach for the removal of heavy hydrocarbons, the heavy hydrocarbons are extracted from the bottoms stream 646 “downstream” from the distillation tower 100. In one example, an adsorptive kinetic separation process is employed downstream of the cryogenic distillation tower.

25 [0309] Figure 14 presents a schematic diagram of a gas processing facility 1400 employing an adsorptive kinetic separation process. This gas processing facility 1400 is generally in accordance with the gas processing facility 1300 of Figure 13. However, in this instance instead of using an AKS solid adsorbent bed 1310 upstream of an acid gas removal system 650, an AKS solid adsorbent bed 1410 is used downstream of the acid gas removal system 100.

[0310] It can be seen in Figure 14 that acid gases, that is, hydrogen sulfide and carbon dioxide, are removed from the distillation tower 100 as a bottom liquefied acid gas stream

642. This liquid stream 642 may optionally be sent through a reboiler 643 where gas containing trace amounts of methane is redirected back into the tower 100 as gas stream 644. The remaining liquid comprised primarily of acid gases is released through acid gas line 646.

[0311] The acid gases from line 646 are delivered to the AKS solid adsorbent bed 1410.

5 The acid gases remain cold and reside in a liquid phase as they pass through the bed 1410. Hydrogen sulfide and any heavy hydrocarbons are removed from the acid gases and released through line 1412 as a natural gas liquids stream 1412. At the same time, acid gases pass through the AKS solid adsorbent bed 1410 and are released as a bottoms acid gas stream 1414.

10 [0312] Acid gases in the bottoms acid gas stream 1414 remain in a primarily liquid phase. The liquefied acid gases in line 1414 are primarily CO₂, and may be vaporized. Alternatively, the liquefied acid gases in line 1414 may be injected into a subsurface formation through one or more acid gas injection (AGI) wells as indicated by block 649. In this instance, the acid gas in line 646 is preferably passed through a pressure booster 648.

15 [0313] It is noted that the natural gas liquids stream 1412 contains heavy hydrocarbons as well as hydrogen sulfide and trace amounts of carbon dioxide. A distillative process is thus undertaken to separate H₂S and CO₂ out of the natural gas liquids stream 1412. A distilling vessel is shown at 1420. H₂S and trace CO₂ gases are released from the distilling vessel 1420 through an overhead line 1424. Line 1424 is preferably merged with bottoms acid gas stream
20 1414 for acid gas injection into reservoir 649. Heavy hydrocarbons exit the vessel 1420 through a bottom line 1422 and are captured for sale.

[0314] Figure 15A is a schematic diagram of a gas processing facility 1500 of the present invention, in another embodiment. In this arrangement, hydrogen sulfide is removed from a gas stream downstream of an acid gas removal system 650 by means of an extractive
25 distillation process. The extractive distillation process is represented by Box 1550.

[0315] This illustrative gas processing facility 1500 is generally in accordance with the gas processing facility 600 of Figure 6. In this respect, a dehydrated gas stream 624 is chilled and then delivered to an acid gas removal system 650 through sour gas line 611. However, instead of using a solvent contacting system 605 along with contacting towers upstream of
30 the acid gas removal system 650, an extractive distillation process is used downstream of the acid gas removal system 650.

[0316] It can be seen in Figure 15A that chilled sour gas passes through line 611 and enters the acid gas removal system 650. The chilled sour gas in line 611 has the same composition as the dehydrated raw gas stream 624. The sour gas in line 611 comprises methane along with hydrogen sulfide and carbon dioxide. Ethane as well as trace elements of nitrogen, helium and aromatics may also be present.

[0317] The sour gas in line 611 first enters the column 100. This may be the same as CFZ tower 100 from Figures 1 and 6. As discussed above, the CFZ tower 100 separates the sour gas into an overhead methane stream 112 and a bottoms acid gas stream 642. In this instance, the bottoms acid gas stream 642 includes both carbon dioxide and hydrogen sulfide.

[0318] The bottoms stream 642 may optionally be sent through a reboiler 643. From there, fluid containing methane is redirected back into the tower 100 as a hydrocarbon gas stream 644. The remaining fluid comprised primarily of hydrogen sulfide and carbon dioxide is released through acid gas line 646. The material in acid gas line 646 is in liquid form, and enters the extractive distillation system 1550.

[0319] Figure 15B is a detailed schematic diagram of the gas processing facility 1550 for the extractive distillation process. Line 646 can be seen carrying acid gases to the extractive distillation facility 1550. In the illustrative arrangement of Figure 15B, three extractive distillation columns 1510, 1520 and 1530 are shown. However, it is understood that more than three columns may be employed.

[0320] The extractive distillation column 1510 is a propane recovery column. The propane recovery column 1510 mixes a hydrocarbon solvent with the acid gas stream 646 in a vessel. The temperature in the first column 1510 is generally -100° to 50° F. In the propane recovery column 1510, solvent absorbs hydrogen sulfide, causing the solvent to leave the column 1510 as a solvent bottoms stream 1514. It will also contain some carbon dioxide as well as heavy hydrocarbons. At the same time, carbon dioxide and trace amounts of light hydrocarbons exit the column 1510 through an overhead stream 1554. The carbon dioxide in stream 1554 may be combined with acid gas injection line 1552 for injection into a subsurface formation (649 in Figure 15A).

[0321] The solvent bottoms stream 1514 enters the second extractive distillation column 1520. The second extractive distillation column 1520 is a CO₂ removal column. The temperature in the CO₂ removal column 1520 is generally 0° to 250° F, which is higher than the temperature in the propane recovery column 1510. In the CO₂ removal column 1520,

solvent and heavy hydrocarbons leave the column 1520 as a second solvent bottoms stream 1524. At the same time, carbon dioxide exits the second column 1520 as an overhead CO₂ stream 1552. The overhead CO₂ stream 1552 is preferably used for enhanced oil recovery.

[0322] A final column 1530 is shown in Figure 15B. The final column 1530 is an additive recovery column. The additive recovery column 1530 uses distillative principles to separate heavy hydrocarbon components, known as "natural gas liquids," from solvent. The temperature in the third column 1530 is generally 80° F to 350° F, which is higher than the temperature in the second column 1530. The natural gas liquids exit the column 1530 through line 1532 and are taken to a treating unit for the removal of any remaining H₂S and CO₂. This treating unit may be a liquid-liquid extractor in which amine is used for H₂S/CO₂ removal, for example.

[0323] Solvent leaves the additive recovery column 1530 as a bottom solvent stream 1534. The bottom solvent stream 1534 represents a regenerated additive. A majority of the bottom solvent stream 1534 is reintroduced into the first column 1510 for the extractive distillation process. Excess solvent from stream 1534 can optionally be combined with the natural gas liquid stream 1532 for treatment via line 1536.

[0324] Referring again to Figure 15A, the carbon dioxide in line 1554 is preferably combined with the CO₂ in line 1552 and passed through a pressure booster 648 and then injected into a subsurface formation through one or more acid gas injection (AGI) wells as indicated by block 649.

[0325] As can be seen, a number of methods may be used to remove sulfurous components in connection with an acid gas removal process. Generally, the method chosen is dependent on the condition of the raw natural gas, or the gas to be treated. For example, if the H₂S concentration is less than about 0.1%, a combined mole sieve approach may be best, since dehydration is required anyway. Molecular sieves have the added benefit of removing some CO₂, which can facilitate a "dirty" startup.

[0326] For cases of about 0.1% to 10% H₂S in the inlet gas, a physical solvent like Selexol™ may be the best option. It would be ideal for the solvent to be dry, as it could be used to dry the inlet gas to some level. For CFZ processing, the gas may require further dehydration by a (smaller) molecular sieve unit. The concentrated H₂S stream from the Selexol unit may be processed in a sulfur recovery unit (SRU), or may be compressed and combined with the CFZ bottom stream for downhole disposal.

[0327] It is understood that the above-described methods for the removal of hydrogen sulfide may be applied in connection with any acid gas removal process, not just a process that utilizes a “controlled freeze zone” tower. Other cryogenic distillation columns may be employed. Further, other cryogenic distillation processes such as bulk fractionation may be used. A bulk fractionation tower is similar to the CFZ tower 100 from Figure 1, but does not have an intermediate freezing zone. A bulk fractionation tower typically operates at a higher pressure than a CFZ tower 100, such as above 700 psig, thereby avoiding CO₂ solids formation. However, the overhead methane stream 112 may contain significant amounts of CO₂. In any instance, utilizing a separate process for the removal of hydrogen sulfide is desirable when the dehydrated gas stream 624 comprises greater than about 3 % C₂ or heavier hydrocarbons.

[0328] While it will be apparent that the inventions herein described are well calculated to achieve the benefits and advantages set forth above, it will be appreciated that the inventions are susceptible to modification, variation and change without departing from the spirit thereof. Improvements to the operation of an acid gas removal process using a controlled freezing zone are provided. The improvements provide a design for the removal of H₂S down to very low levels in the product gas.

CLAIMS

What is claimed is:

1. A system for removing acid gases from a sour gas stream, comprising:
an acid gas removal system for receiving the sour gas stream, wherein the acid gas
5 removal system utilizes a cryogenic distillation tower that separates the sour gas stream into
an overhead gas stream comprised primarily of methane, and a liquefied bottom acid gas
stream comprised primarily of carbon dioxide; and
a sulfurous components removal system upstream of the acid gas removal system,
wherein the sulfurous components removal system receives a raw gas stream and generally
10 separates the raw gas stream into a hydrogen sulfide stream and the sour gas stream.
2. The system of claim 1, wherein the raw gas stream contains between about 4 ppm and
100 ppm sulfurous components.
- 15 3. The system of claim 2, wherein the cryogenic acid gas removal system further
comprises a heat exchanger for chilling the sour gas stream before entry into the cryogenic
distillation tower.
4. The system of claim 3, wherein:
20 the cryogenic distillation tower comprises a lower distillation zone and an
intermediate controlled freezing zone that receives a cold liquid spray comprised primarily of
methane, the tower receiving and then separating the sour gas stream into an overhead
methane stream and the bottom acid gas stream; and
refrigeration equipment downstream of the cryogenic distillation tower for cooling
25 the overhead methane stream and returning a portion of the overhead methane stream to the
cryogenic distillation tower as the cold spray.
5. The system of claim 2, wherein the acid gas removal system is a bulk fractionation
system.
- 30 6. The system of claim 2, wherein the sulfurous components removal system comprises
a chemical solvent system.

7. The system of claim 6, wherein the chemical solvent comprises methyl diethanol amine (MDEA), a selective amine from a Flexsorb[®] family of solvents, or combinations thereof.

5 8. The system of claim 6, wherein the chemical solvent system utilizes a plurality of co-current contactors.

9. The system of claim 8, wherein the co-current contactors of the chemical solvent system comprise:

10 a first co-current contactor configured to receive (i) the raw gas stream and (ii) a second liquid solvent, the first co-current contactor also being configured to release (iii) a first partially-sweetened gas stream comprised primarily of methane and (iv) a first partially-loaded gas-treating solution;

a second co-current contactor configured to receive (i) the first partially-sweetened
15 gas stream and (ii) a third liquid solvent, and is configured to release (iii) a second partially-sweetened gas stream and (iv) a second partially-loaded gas-treating solution; and

a final co-current contactor configured to receive (i) a previous partially-sweetened
gas stream, and (ii) a regenerated liquid solvent, and configured to release (iii) a final
sweetened gas stream comprised primarily of methane, and (iv) a final lightly-loaded gas-
20 treating solution;

wherein:

the hydrogen sulfide stream is comprised at least in part of the first partially-
loaded gas-treating solution and the second partially-loaded gas-treating solution; and

25 the regenerated liquid solvent is comprised at least in part of a regenerated solvent stream whereby the hydrogen sulfide has been substantially removed from at least the first partially-loaded gas-treating solution and the second partially-loaded gas-treating solution.

10. The chemical solvent system of claim 9, further comprising:

30 a liquid solvent regenerator configured to receive at least the first partially-loaded gas-treating solution, and to produce the regenerated liquid solvent.

11. The gas processing facility of claim 9, wherein:
the liquid solvent and the regenerated liquid solvent comprise a hindered amine, a tertiary amine, or combinations thereof.

5 12. The system of claim 8, wherein the co-current contactors of the chemical solvent system comprise:

a first co-current contactor, a second co-current contactor and a final co-current contactor, each of these co-current contactors being configured (i) to receive the raw gas stream and a liquid solvent, and (ii) to release a sweetened gas stream and a separate loaded gas-treating solution;

10 the first co-current contactor, the second co-current contactor and the final co-current contactor being configured to deliver the respective sweetened gas streams as progressively sweetened gas streams in series; and

15 the final co-current contactor, the second co-current contactor and the first co-current contactor being arranged to deliver the respective gas-treating solutions as progressively richer gas-treating solutions in series.

13. The method of claim 12, wherein:

20 the first co-current contactor receives (i) the initial gas stream and a (ii) second liquid solvent, and releases (iii) a first partially-sweetened gas stream and (iv) a first partially-loaded gas-treating solution;

the second co-current contactor receives (i) the first partially-sweetened gas stream from the first co-current contactor and (ii) a third liquid solvent, and releases (iii) a second partially-sweetened gas stream and (iv) a second partially-loaded gas-treating solution, and

25 the final co-current contactor receives (i) a previous partially-sweetened gas stream and (ii) a regenerated liquid solvent, and releases (iii) a final sweetened gas stream and (iv) a final lightly-loaded gas-treating solution.

14. The system of claim 2, wherein the sulfurous components removal system comprises
30 a physical solvent system that utilizes a physical solvent.

15. The system of claim 14, wherein the physical solvent comprises N-methyl pyrrolidone, propylene carbonate, methyl cyanoacetate, refrigerated methanol, tetramethylene sulfone, Selexol™, or combinations thereof.

- 5 16. The system of claim 14, wherein the physical solvent system comprises:
an absorber for receiving the raw gas stream and separating the raw gas stream into the sour gas stream and the hydrogen sulfide stream, the hydrogen sulfide stream comprising hydrogen sulfide and a liquid physical solvent;
at least two separators for processing the hydrogen sulfide stream so as to separate
10 hydrogen sulfide from physical solvent; and
a regenerator for regenerating the physical solvent and returning at least a part of the physical solvent to the absorber.

17. The system of claim 2, wherein:

- 15 the sulfurous components removal system comprises at least one solid adsorbent bed for substantially adsorbing sulfurous components, the sulfurous components being released as the hydrogen sulfide stream when the at least one solid adsorbent bed is regenerated; and
the at least one solid adsorbent bed substantially passes methane and CO₂ as the sour
gas stream.

20

18. The system of claim 17, wherein the solid adsorbent bed (i) is fabricated from a zeolite material, or (ii) comprises at least one molecular sieve.

19. The system of claim 18, wherein the sulfurous components removal system further
25 comprises a separator for separating carbon dioxide from sulfurous components in the hydrogen sulfide stream.

20. The system of claim 17, wherein the regeneration is part of a pressure-swing adsorption process.

30

21. The system of claim 20, wherein the at least one solid adsorbent bed comprises at least three adsorbent beds, with:

a first of the at least three adsorbent beds being in service for adsorbing hydrogen sulfide;

a second of the at least three adsorbent beds undergoes regeneration; and

a third of the at least three adsorbent beds is held in reserve to replace the first of the
5 at least three adsorbent beds.

22. The system of claim 21, wherein the sulfurous components removal system further comprises a vacuum for applying negative relative pressure to the first of the at least three adsorbent beds to aid in desorbing hydrogen sulfide from the first of the at least three
10 adsorbent beds before the hydrogen sulfide stream enters the separator.

23. The system of claim 17, wherein the regeneration is part of a thermal-swing adsorption process.

15 24. The system of claim 23, wherein the at least one solid adsorbent bed comprises at least three adsorbent beds, with:

a first of the at least three adsorbent beds being in service for adsorbing hydrogen sulfide;

a second of the at least three adsorbent beds undergoes regeneration; and

20 a third of the at least three adsorbent beds is held in reserve to replace the first of the at least three adsorbent beds.

25. The system of claim 24, wherein:

the sulfurous components removal system further comprises a regeneration gas heater
25 for (i) receiving a regenerating gas, (ii) heating the regenerated gas, and (iii) desorbing hydrogen sulfide from the second adsorbent bed by applying heat from the heated regenerated gas to the second adsorbent bed;

the regeneration gas heater releases a gas stream to the first solid adsorbent bed for separation of the gas stream into the hydrogen sulfide stream and the sour gas stream; and

30 the sulfurous components removal system further comprises a separator for separating out any methane from the hydrogen sulfide stream.

26. The system of claim 25, wherein the sulfurous components removal system further comprises a cooler for receiving the hydrogen sulfide stream and chilling the hydrogen sulfide fluid stream before it enters the separator.

5 27. The system of claim 2, wherein:

the sulfurous components removal system comprises at least one solid adsorbent bed for substantially adsorbing hydrogen sulfide, the hydrogen sulfide being released as the hydrogen sulfide stream when the at least one solid adsorbent bed is regenerated; and

10 the at least one solid adsorbent bed substantially passes methane and carbon dioxide as the sour gas stream.

28. The system of claim 27, wherein the at least one solid adsorbent bed is an adsorptive kinetic separations bed.

15 29. The system of claim 2, wherein the sulfurous components removal system comprises a redox system.

30. The system of claim 29, wherein the redox system comprises:

20 a contactor for receiving the raw gas stream and a chelated oxidized metal, the chelated oxidized metal mixing with the raw gas stream so as to cause a reduction-oxidation reaction and to release (i) a bottom aqueous solution comprising a chelated reduced metal and elemental sulfur, and (ii) an overhead gas stream comprised of methane and carbon dioxide;

25 an oxidizer for receiving the bottom aqueous solution along with air, and providing a chamber for an oxidation reaction, the oxidizer releasing an aqueous chelated metal mixture with elemental sulfur;

a separator for receiving the aqueous chelated metal mixture with elemental sulfur, and separating the aqueous chelated metal mixture with elemental sulfur into a regenerated chelated metal catalyst solution and elemental sulfur; and

30 a line for directing at least a portion of the regenerated chelated metal catalyst solution back into the contactor.

31. The system of claim 2, wherein the sulfurous components removal system comprises a scavenger system.

32. The system of claim 31, wherein the scavenger system comprises:

a line wherein a liquid scavenging agent is mixed with the raw gas stream;

5 a separating vessel for separating the raw gas stream into the sour gas stream and a spent scavenger stream, the spent scavenger stream comprising hydrogen sulfide and the liquid scavenging agent.

33. The system of claim 2, wherein the overhead gas stream comprises not only methane, but also helium, nitrogen, or combinations thereof.

10

34. The system of claim 2, wherein the sulfurous components removal system comprises a system for implementing a CrystaSulf process.

35. The system of claim 34, wherein the sulfurous components removal system further
15 comprises:

an absorber for receiving (i) the sour gas stream and (ii) an oxidizing gas as a scrubbing liquor, the oxidizing gas mixing with the raw gas stream so as to cause a chemical reaction such that the absorber (i) releases the sour gas stream and (ii) releases a sorbent comprised of water, hydrogen sulfide and the oxidizing gas;

20 a flask for separating the liquid sorbent into (i) an overhead vapor stream comprised primarily of hydrocarbon gases and any entrained water vapor, and (ii) a sulfur solution;

a separating vessel for separating water from the hydrocarbon gases and delivering the hydrocarbon gases back to the raw gas stream;

25 a crystallizer for receiving the sulfur solution, the crystallizer seeding the sulfur solution with sulfur crystals in a settling zone to effect precipitation of dissolved sulfur, the crystallizer (i) releasing a sulfur slurry from a lower portion of the crystallizer, and (ii) directing a liquor from an upper portion of the crystallizer as the oxidizing gas, with a portion of the liquor being directed back to the absorber; and

30 a filter for separating the sulfur slurry into pure solid sulfur and a clear liquor, the clear liquor being directed back to the crystallizer.

36. The system of claim 2, further comprising:

a dehydration apparatus for receiving the raw gas stream before it passes through the sulfurous components removal system, and separating the raw gas stream into a dehydrated raw gas stream and a stream comprised substantially of an aqueous fluid; and

5 wherein the raw gas stream received by the sulfurous components removal system is the dehydrated raw gas stream.

37. A system for removing acid gases from a sour gas stream, comprising:

10 an acid gas removal system for receiving the sour gas stream, the sour gas stream comprising less than about 10% sulfurous components, wherein the acid gas removal system utilizes a cryogenic distillation tower that separates the sour gas stream into an overhead gas stream comprised primarily of methane, and a liquid bottom acid gas stream comprised primarily of carbon dioxide and sulfurous components; and

15 a sulfurous components removal system downstream of the acid gas removal system, wherein the sulfurous components removal system receives the bottom acid gas stream and generally separates the bottom acid gas stream into a carbon dioxide fluid stream and a hydrogen sulfide stream.

38. The system of claim 37, wherein the acid gas removal system further comprises a heat
20 exchanger for chilling the sour gas stream before entry into the distillation tower.

39. The system of claim 38, wherein the cryogenic distillation tower comprises:

25 a lower distillation zone and an intermediate controlled freezing zone that receives a cold liquid spray comprised primarily of methane, the tower receiving and then separating the sour gas stream into an overhead methane stream and a bottom liquefied acid gas stream; and

refrigeration equipment downstream of the cryogenic distillation tower for cooling the overhead methane stream and returning a portion of the overhead methane stream to the cryogenic distillation tower as liquid reflux.

30 40. The system of claim 37, wherein the sulfurous components removal system comprises:

at least one solid adsorbent bed for substantially adsorbing hydrogen sulfide from the bottom acid gas stream, the hydrogen sulfide being released as the hydrogen sulfide stream when the at least one solid adsorbent bed is regenerated; and

the at least one solid adsorbent bed substantially passes acid gases comprising carbon dioxide as the carbon dioxide fluid stream.

41. The system of claim 40, wherein the at least one solid adsorbent bed comprises at least one adsorptive kinetic separations bed.

10 42. The system of claim 37, wherein the sulfurous components removal system comprises an extractive distillation system having at least two extractive distillation columns.

43. The system of claim 42, wherein the extractive distillation system comprises:

15 a first extractive distillation column that serves as a propane recovery column, the propane recovery column mixing a solvent with the acid gas stream to absorb acid gases, causing the solvent to leave the column as a solvent bottoms stream while separately releasing the carbon dioxide stream;

20 a second extractive distillation column that serves as a CO₂ removal column, the CO₂ removal column causing solvent and heavy hydrocarbons to leave the acid gas removal column as a second solvent bottoms stream while separately releasing the CO₂; and

25 a third extractive distillation column that serves as an additive recovery column, the additive recovery column using distillative principles to separate heavy hydrocarbon components, known as "natural gas liquids," from solvent such that a bottom solvent stream is released as a regenerated additive, while natural gas liquids separately exit the column overhead.

44. The system of claim 37 wherein the sour gas stream comprises less than about 1% sulfurous components.

30 45. The system of claim 37 wherein the sour gas stream comprises between about 4 ppm and 100 ppm sulfurous components.

1/15

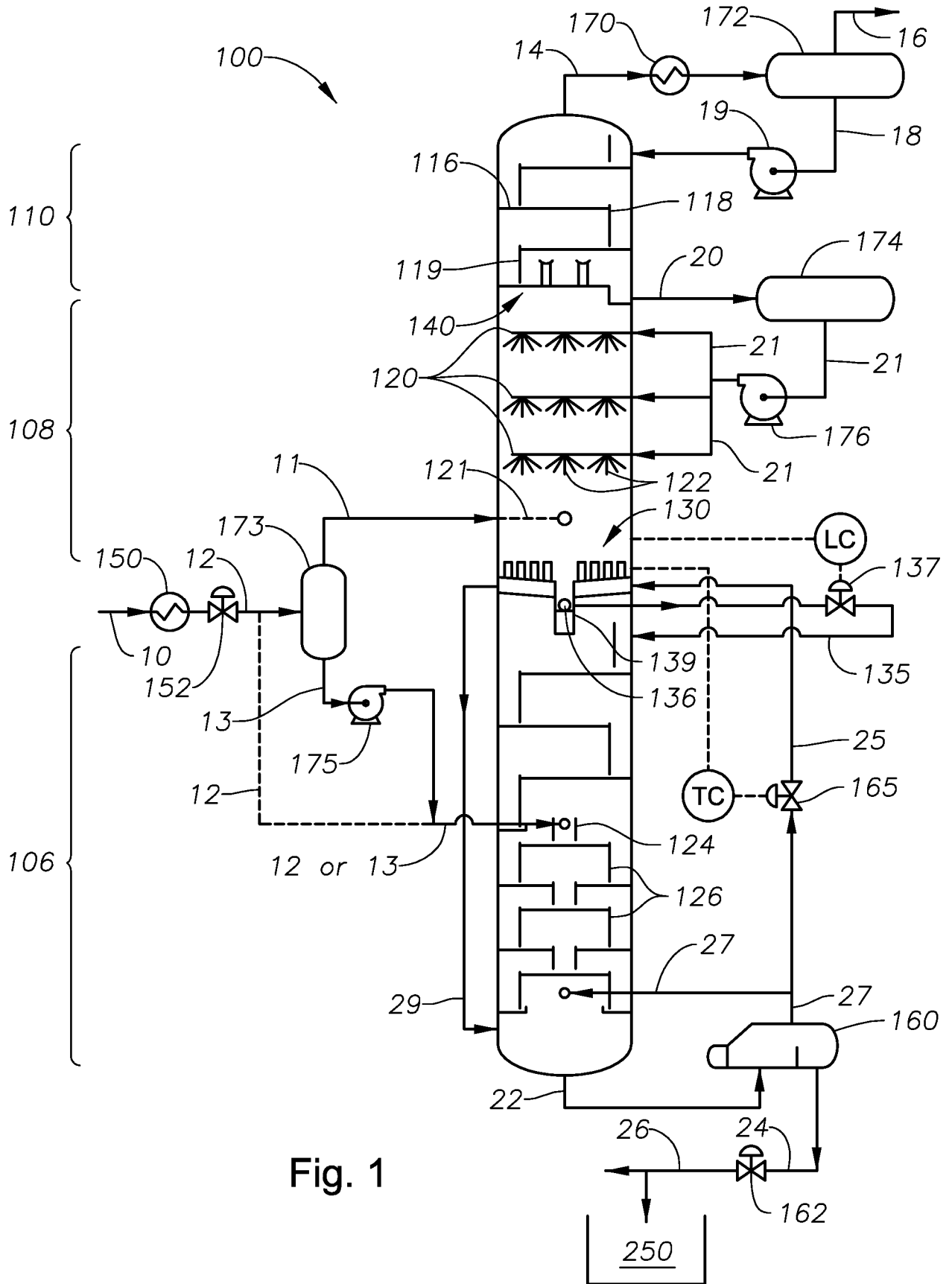

Fig. 1

2/15

Fig. 2A

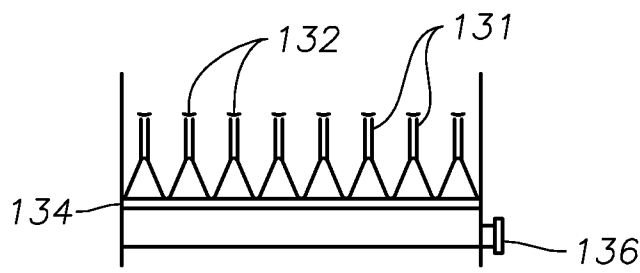
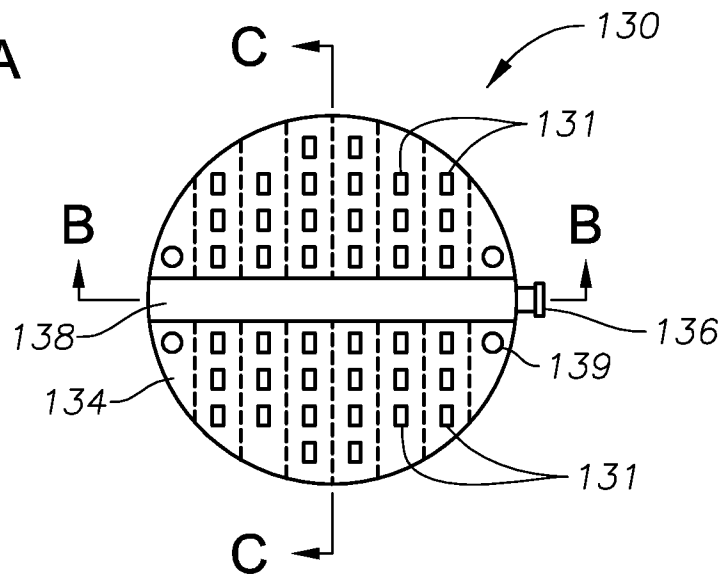

Fig. 2B

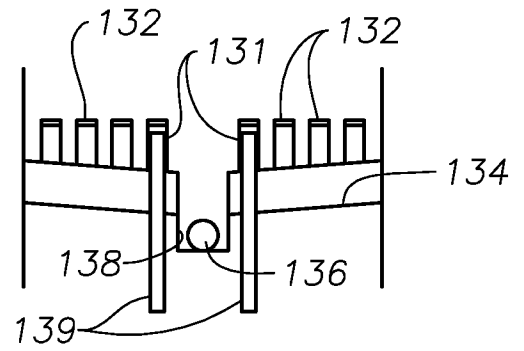

Fig. 2C

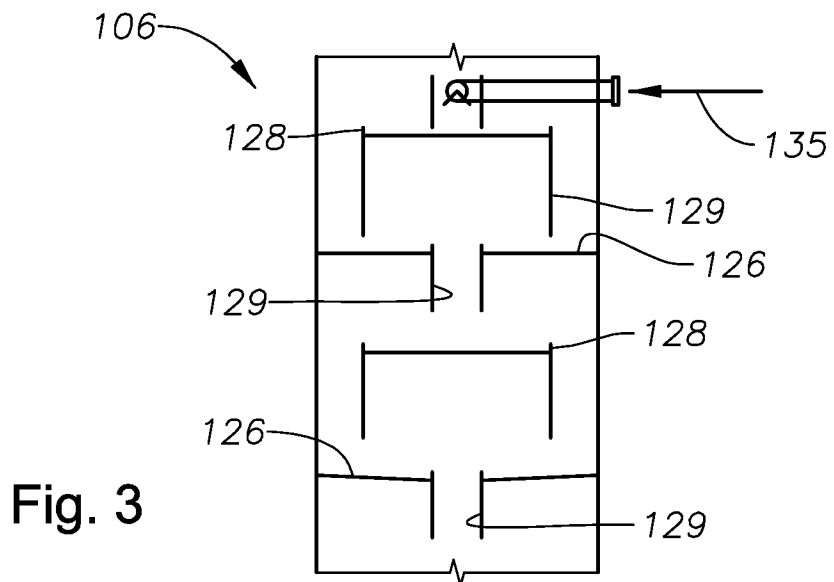

Fig. 3

3/15

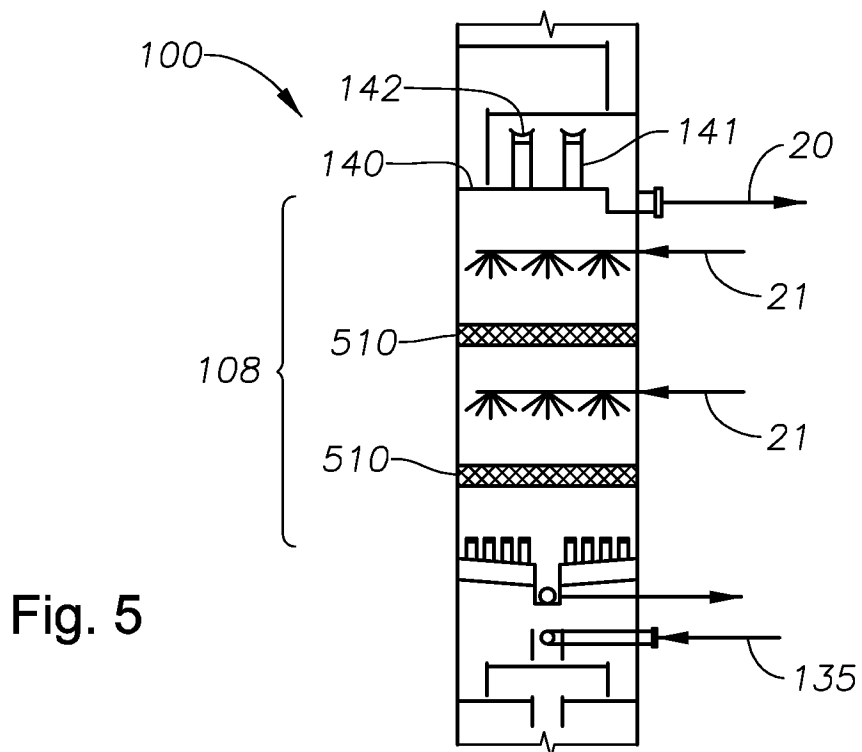
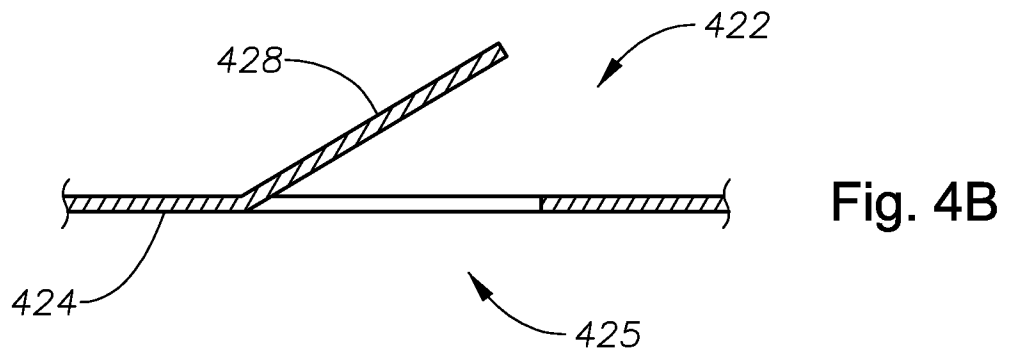
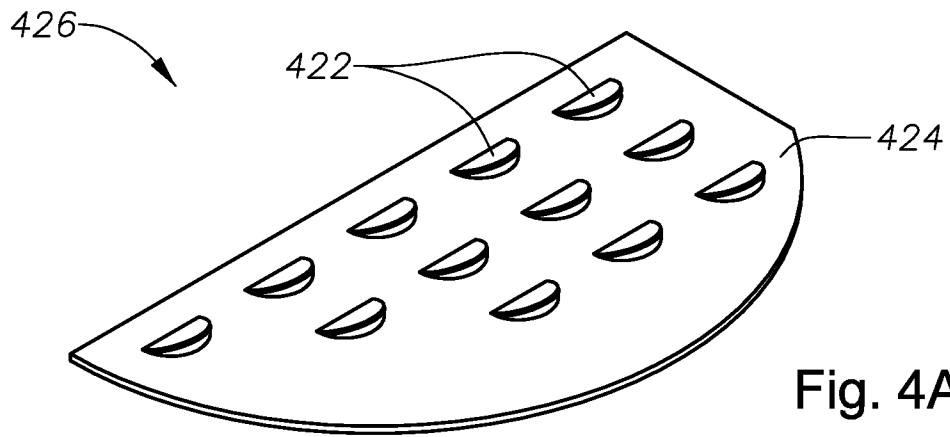
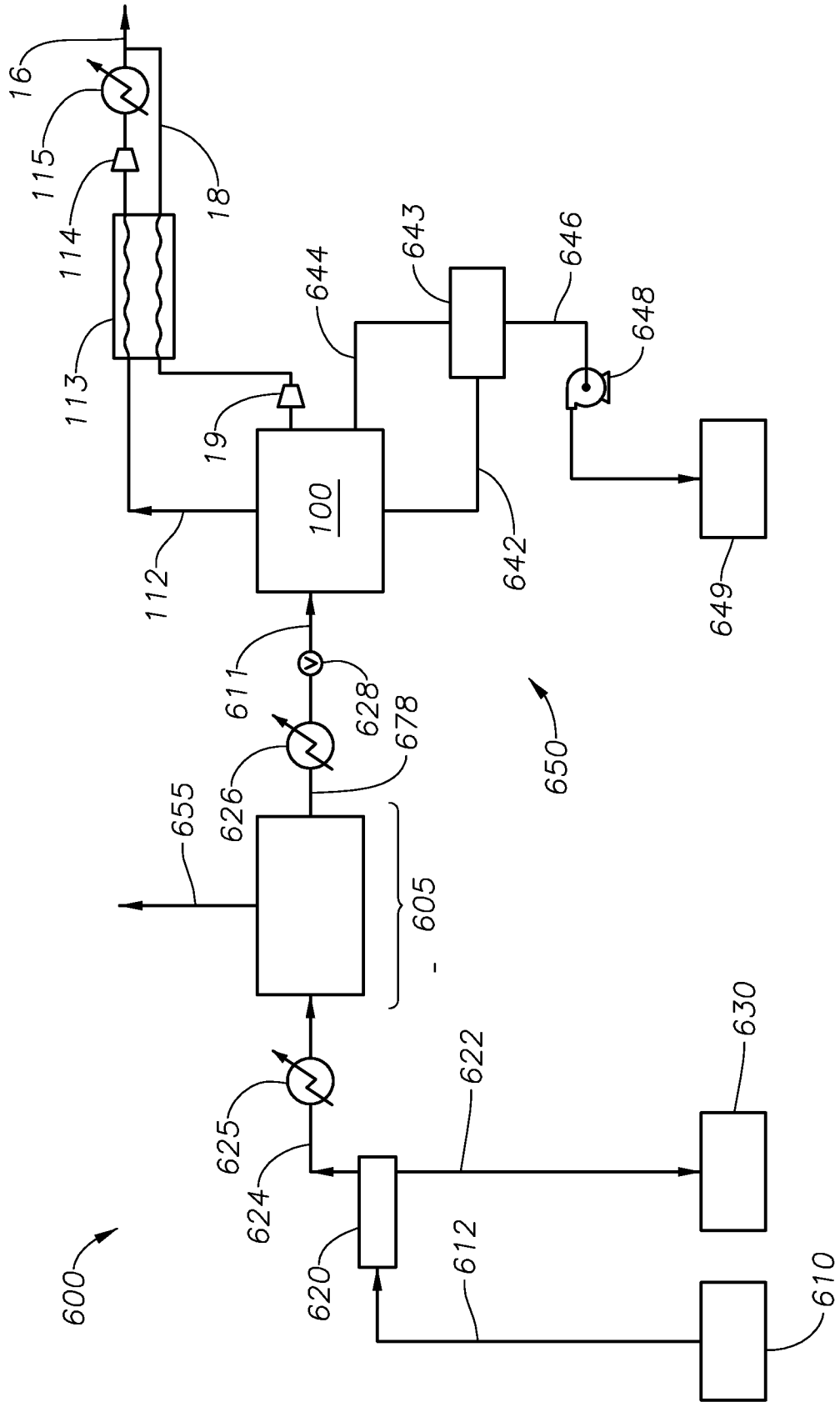

Fig. 6



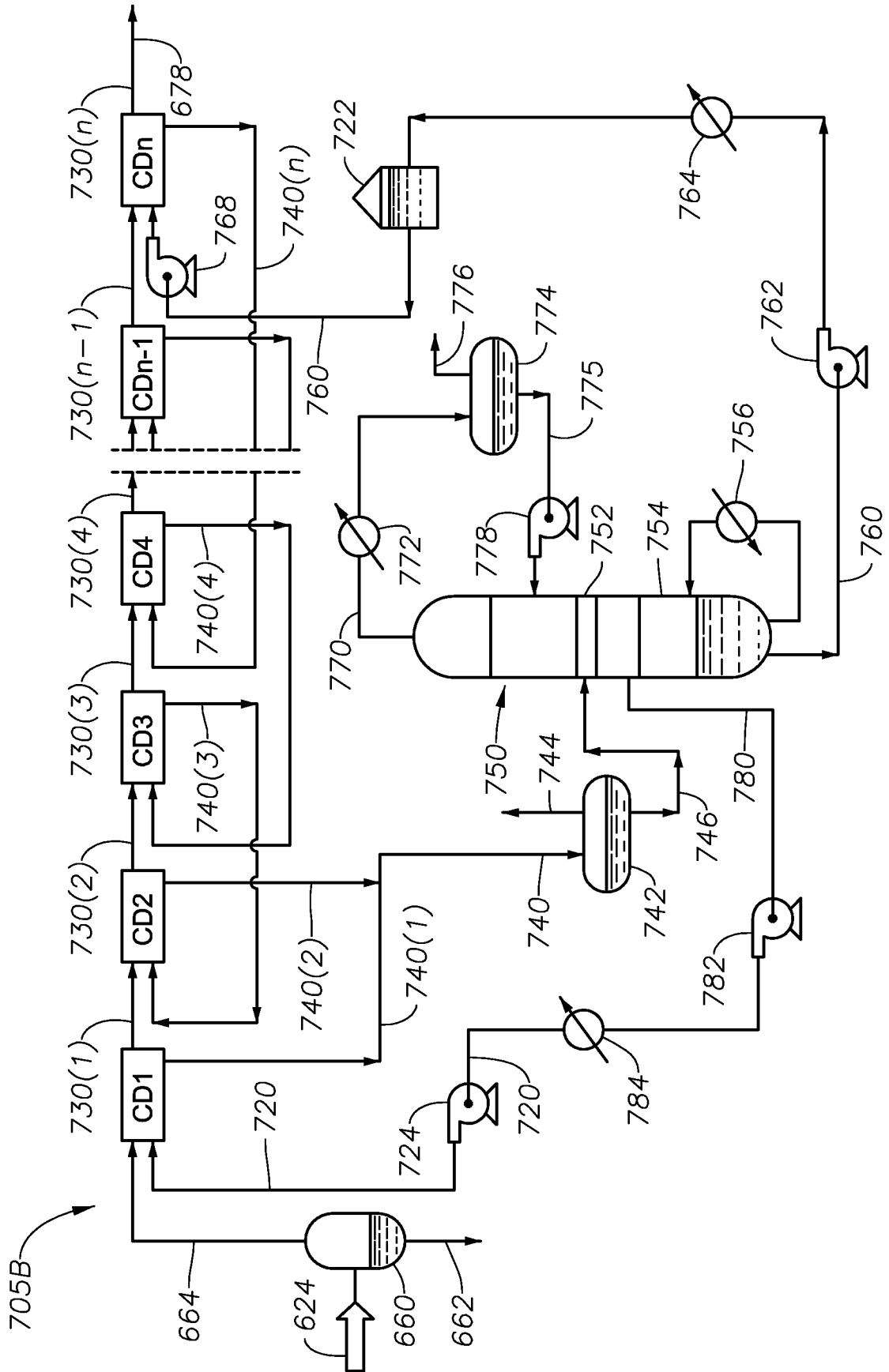

Fig. 7B

Fig. 8

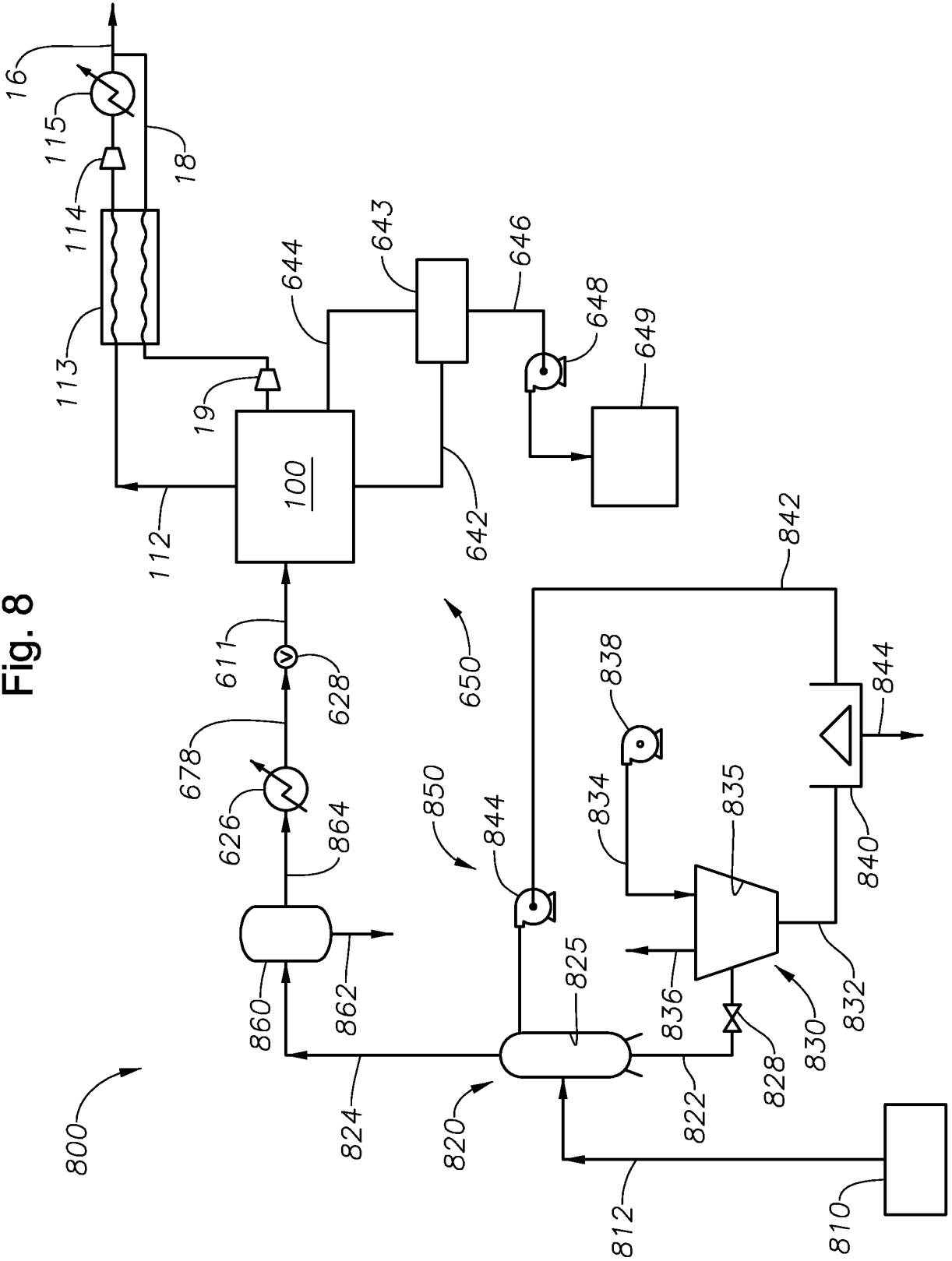

Fig. 9

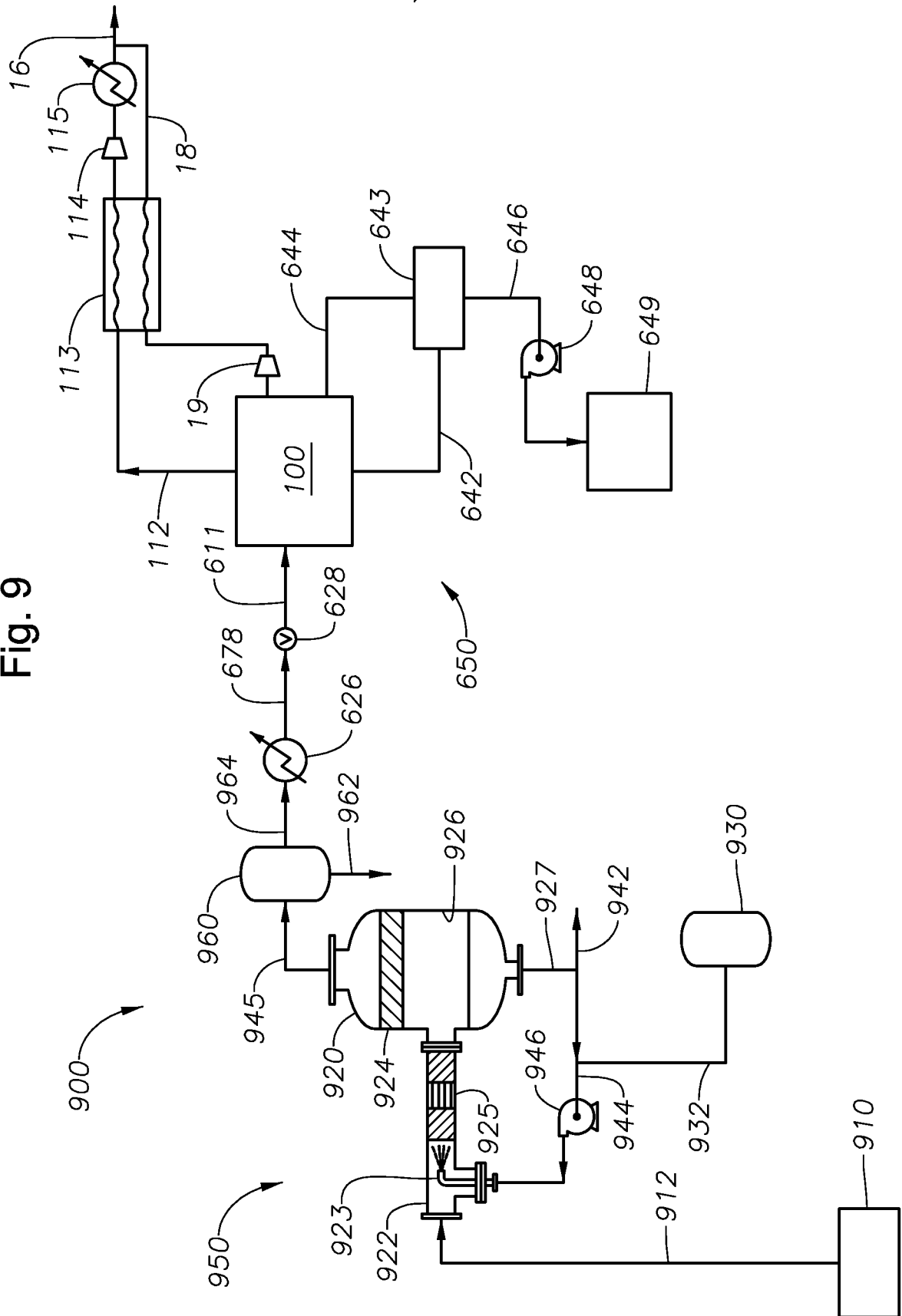

Fig. 10

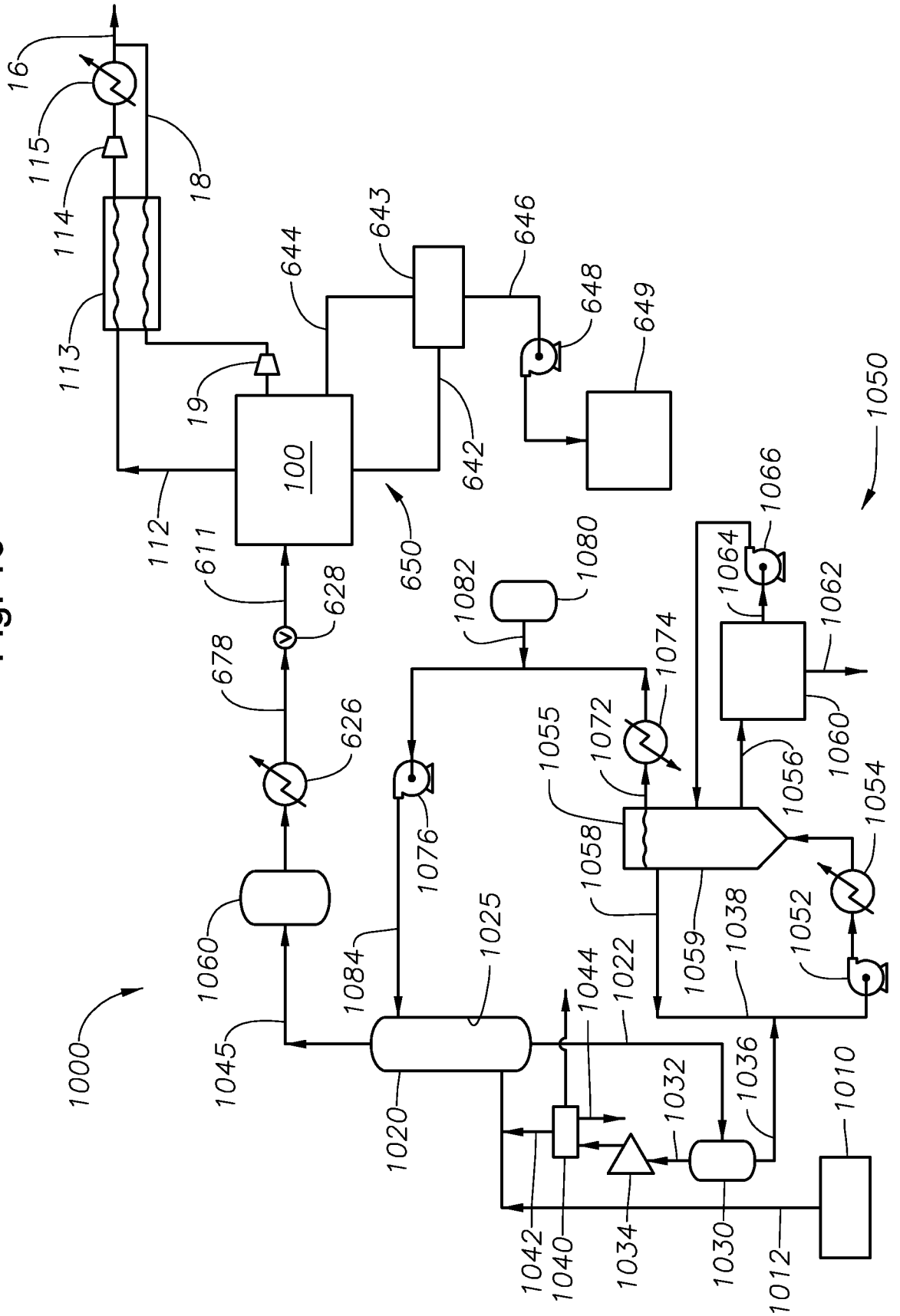

Fig. 11

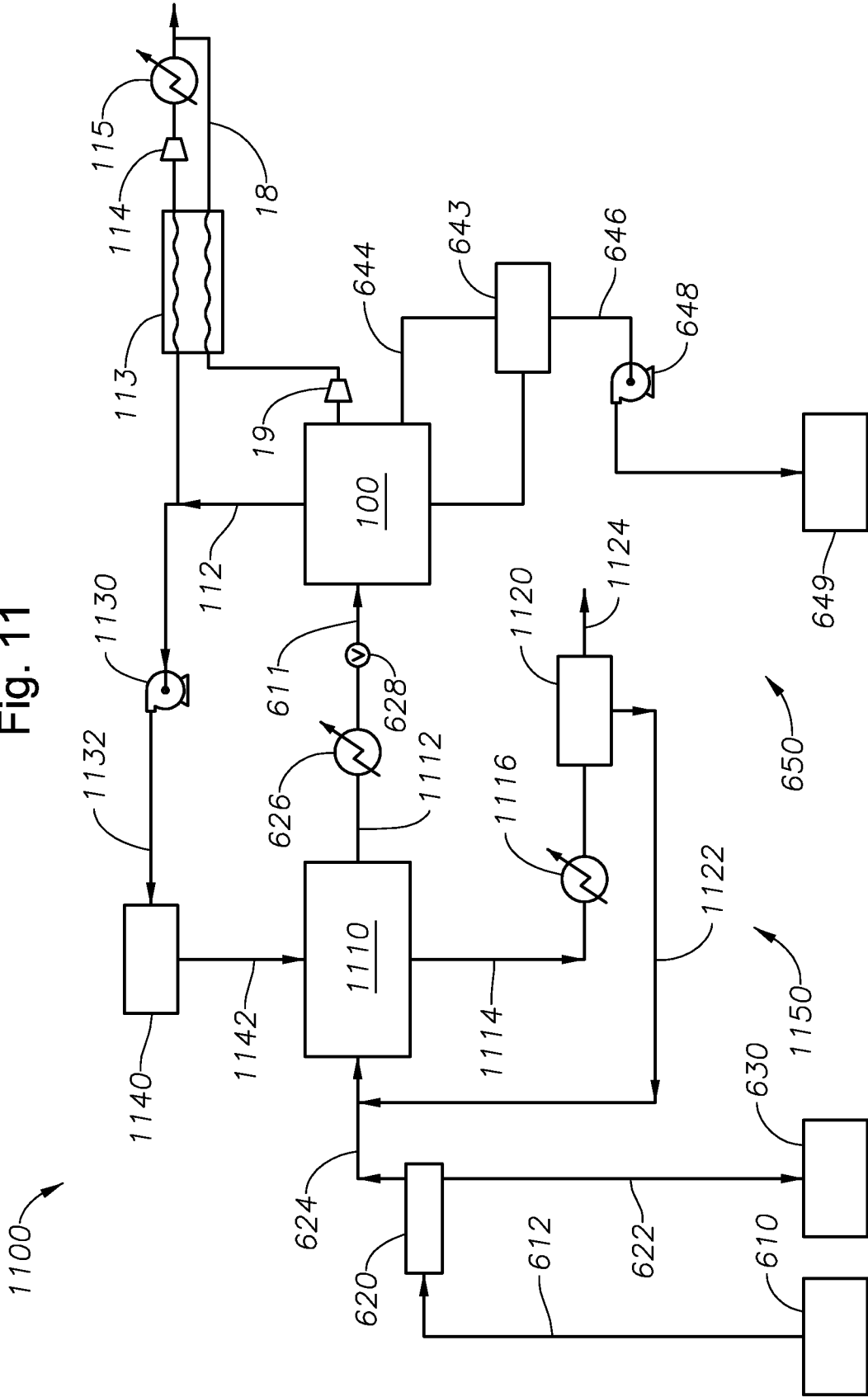

Fig. 12

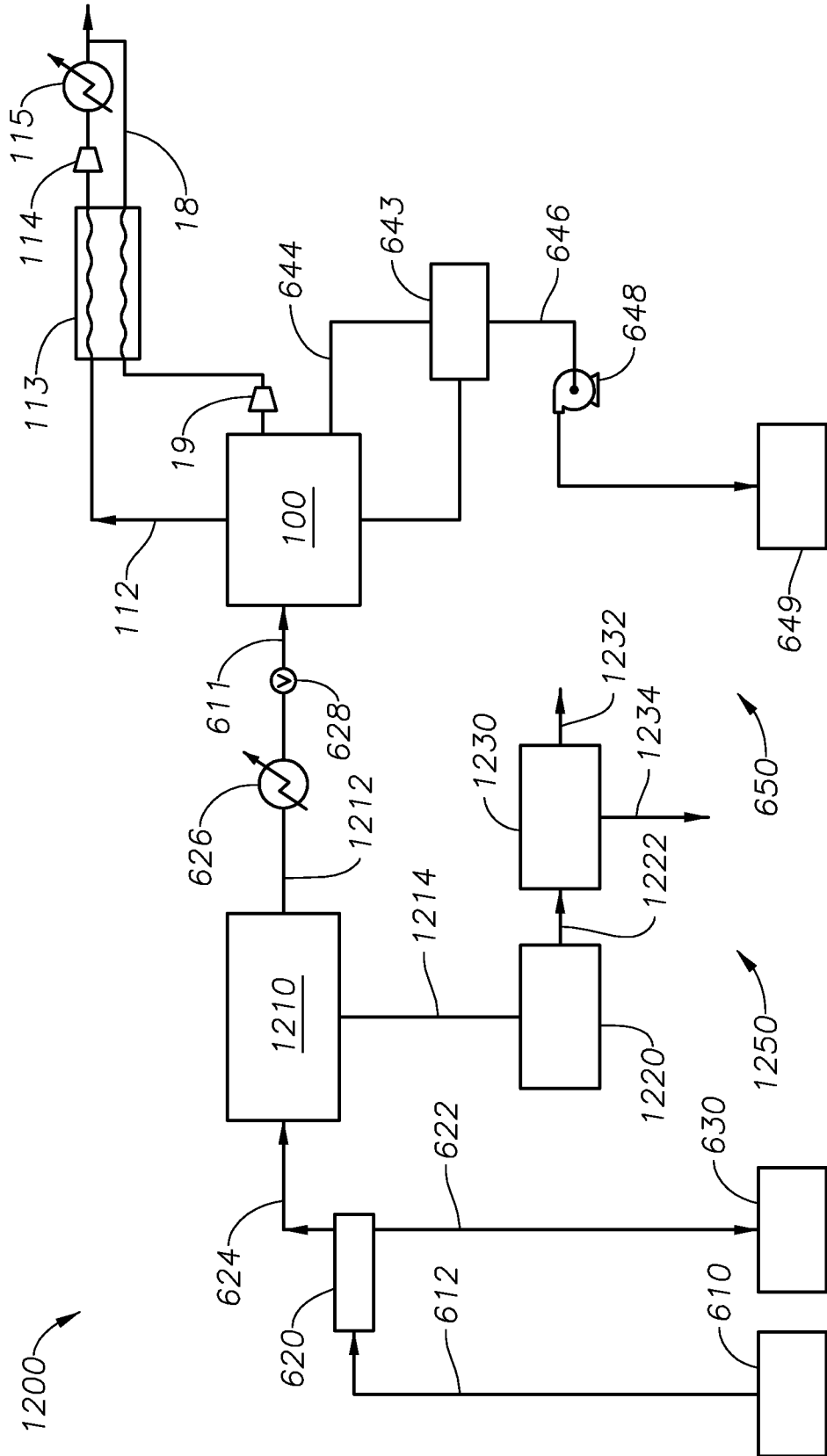

Fig. 13

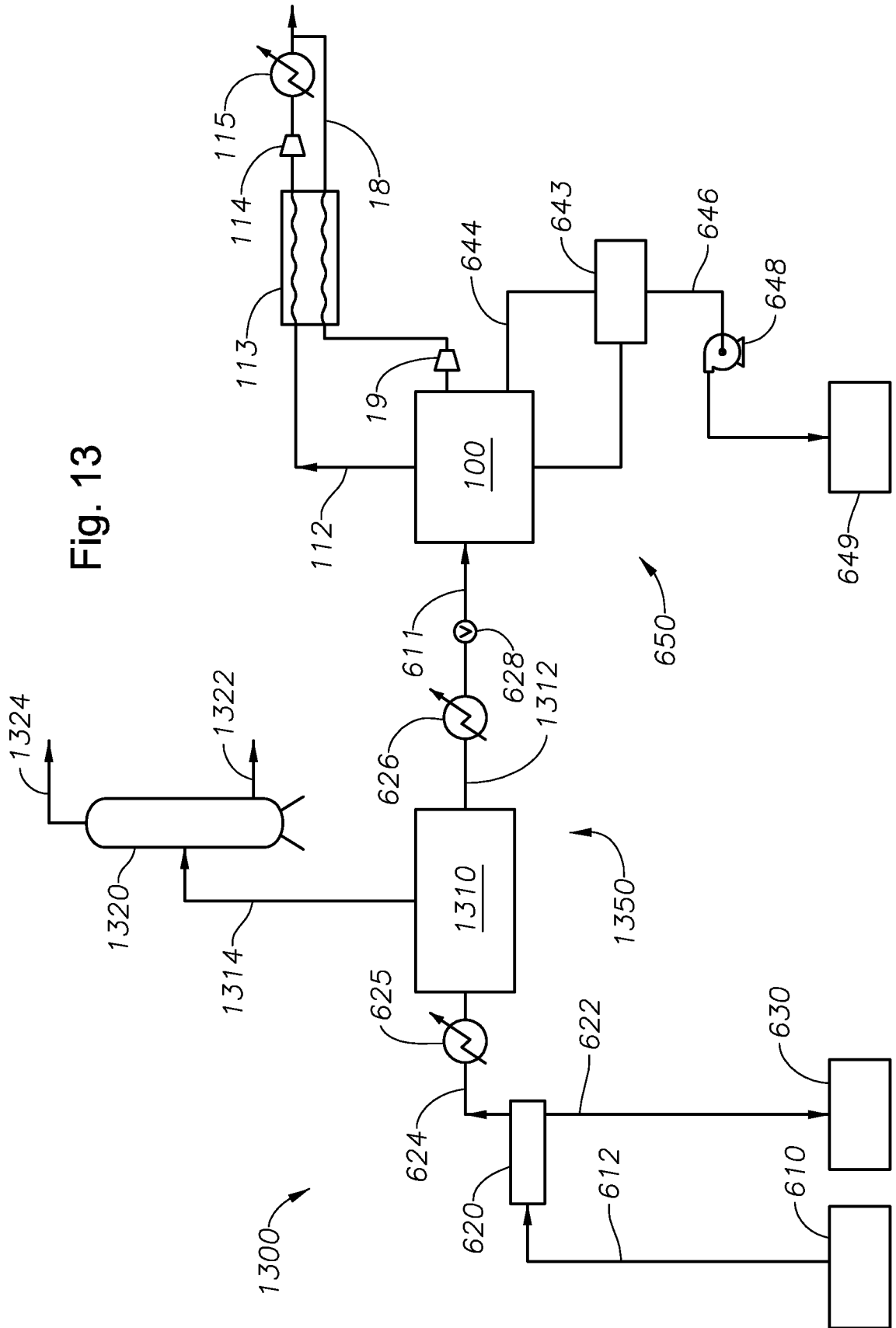

Fig. 14

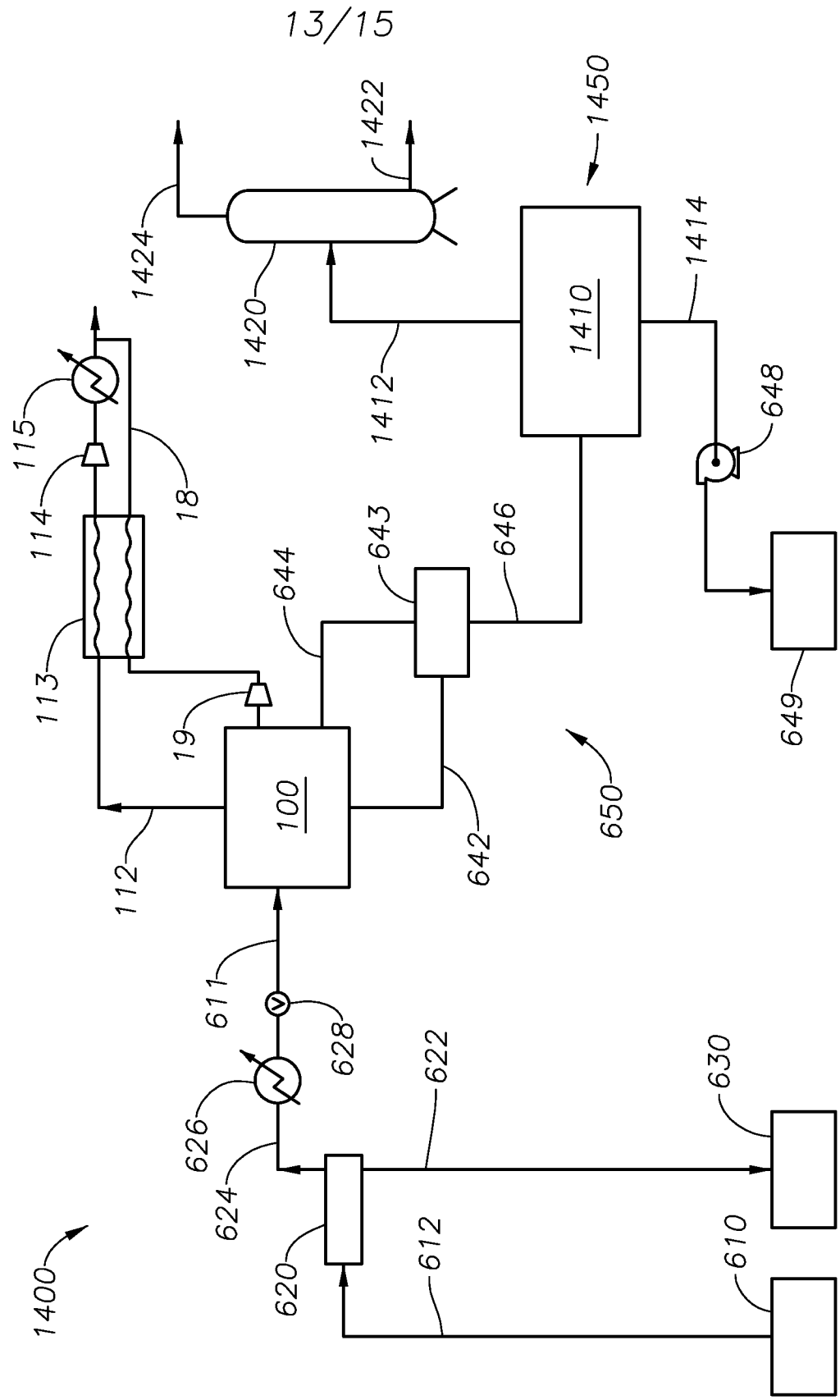

Fig. 15A

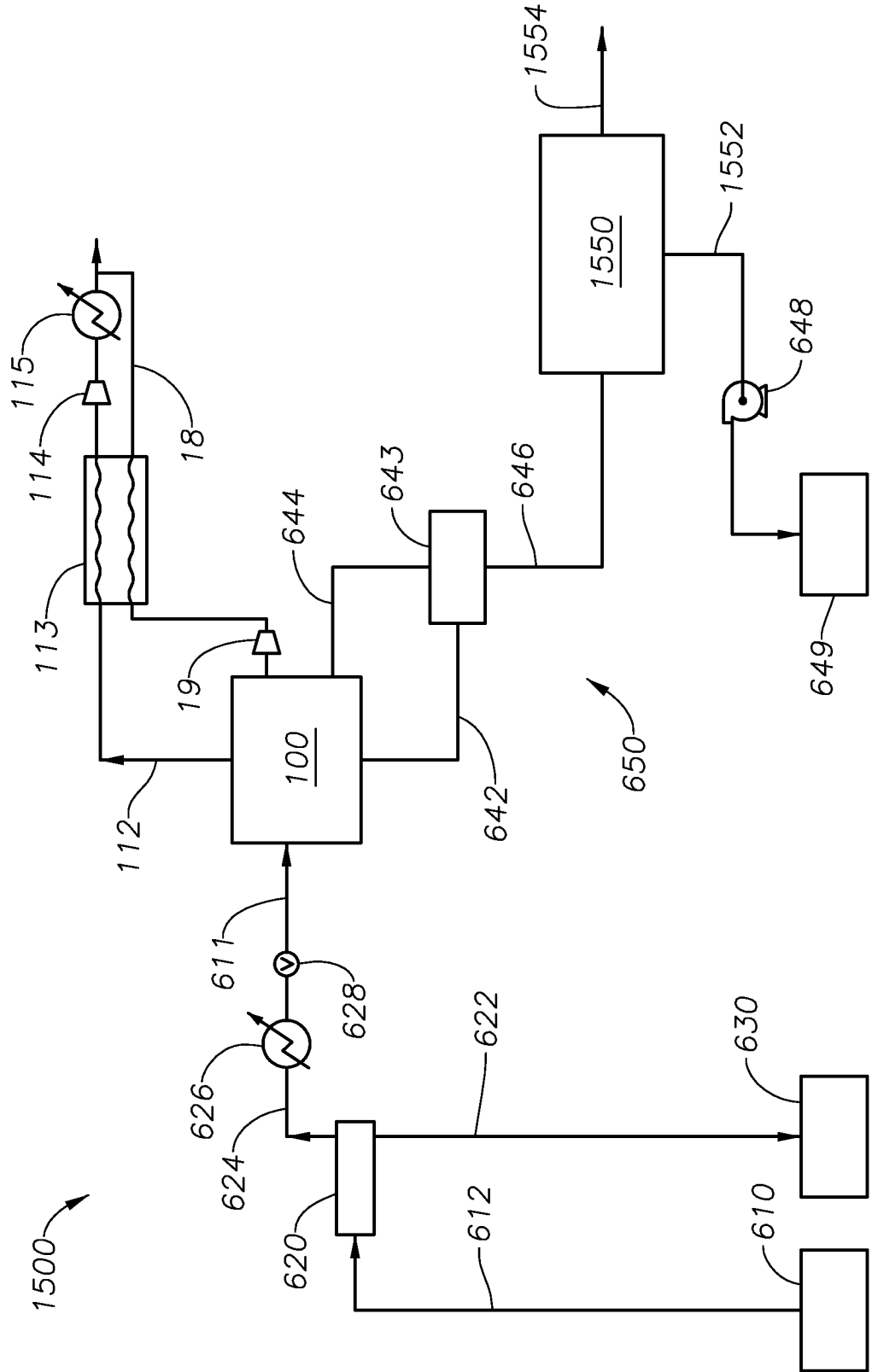
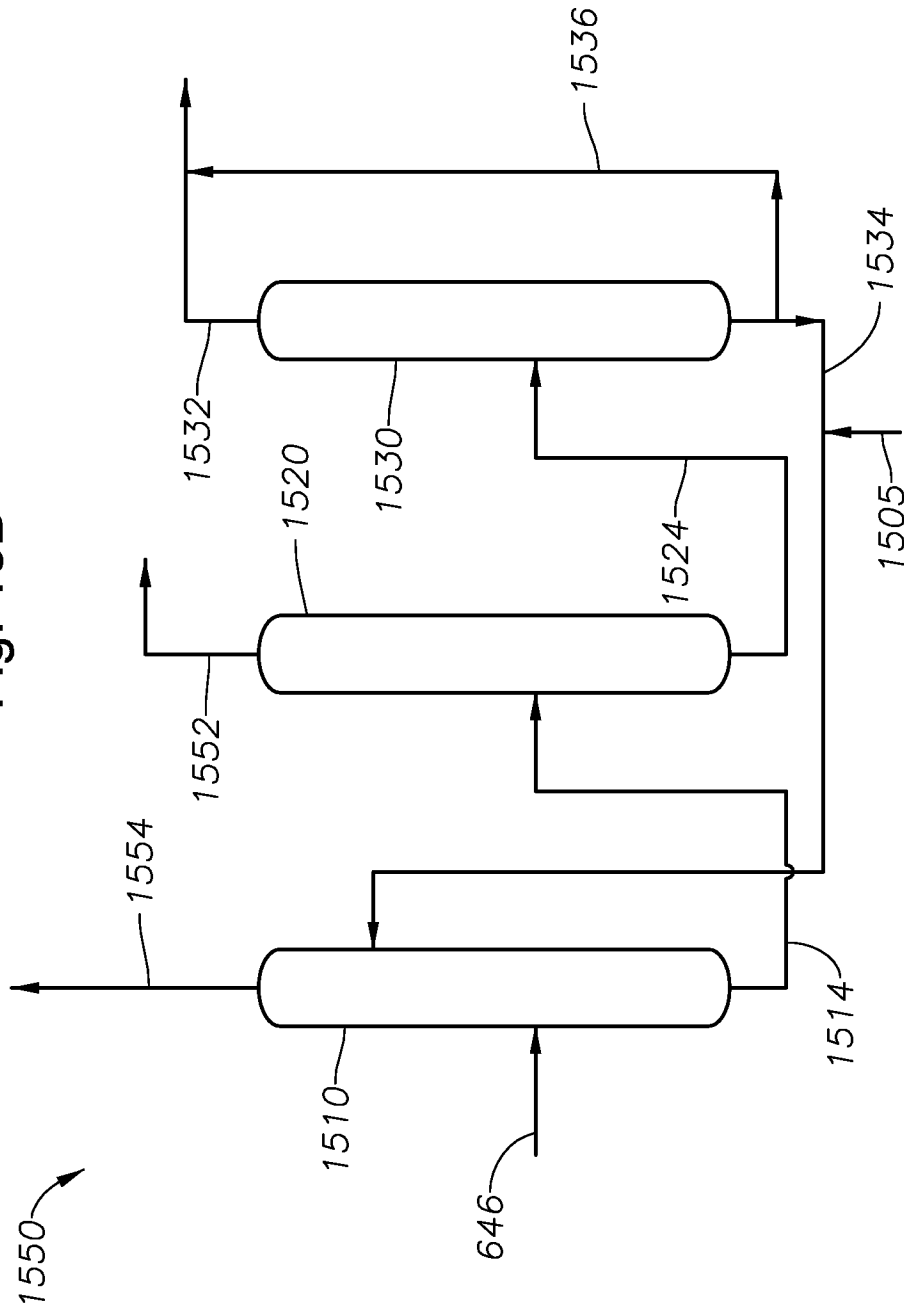

Fig. 15B



INTERNATIONAL SEARCH REPORT

International application No.

PCT/US2010/044137

A. CLASSIFICATION OF SUBJECT MATTER

IPC(8) - F25J 3/00 (2010.01)

USPC - 62/623

According to International Patent Classification (IPC) or to both national classification and IPC

B. FIELDS SEARCHED

Minimum documentation searched (classification system followed by classification symbols)

IPC(8) - B01D 5/00; C01B 31/20; F25J 3/00 (2010.01)

USPC - 62/620, 623, 631

Documentation searched other than minimum documentation to the extent that such documents are included in the fields searched

Electronic data base consulted during the international search (name of data base and, where practicable, search terms used)

MicroPatent, Freepatentsonline, Google

C. DOCUMENTS CONSIDERED TO BE RELEVANT

Category*	Citation of document, with indication, where appropriate, of the relevant passages	Relevant to claim No.
Y	US 2008/0034789 A1 (FIELER et al) 14 February 2008 (14.02.2008) entire document	1-45
Y	US 2009/0220406 A1 (RAHMAN) 03 September 2009 (03.09.2009) entire document	1-45
Y	US 2009/0261017 A1 (IQBAL et al) 22 October 2009 (22.10.2009) entire document	9-13, 16, 20-30, 32, 34, 35, 37-45
Y	US 4,831,206 A (ZARCHY) 16 May 1989 (16.05.1989) entire document	25-28
Y	EP 0 508 244 B1 (HARDISON) 14 October 1992 (14.10.1992) entire document	30, 35

 Further documents are listed in the continuation of Box C.

* Special categories of cited documents:	"T" later document published after the international filing date or priority date and not in conflict with the application but cited to understand the principle or theory underlying the invention
"A" document defining the general state of the art which is not considered to be of particular relevance	"X" document of particular relevance; the claimed invention cannot be considered novel or cannot be considered to involve an inventive step when the document is taken alone
"E" earlier application or patent but published on or after the international filing date	"Y" document of particular relevance; the claimed invention cannot be considered to involve an inventive step when the document is combined with one or more other such documents, such combination being obvious to a person skilled in the art
"L" document which may throw doubts on priority claim(s) or which is cited to establish the publication date of another citation or other special reason (as specified)	"&" document member of the same patent family
"O" document referring to an oral disclosure, use, exhibition or other means	
"P" document published prior to the international filing date but later than the priority date claimed	

Date of the actual completion of the international search

27 September 2010

Date of mailing of the international search report

04 OCT 2010

Name and mailing address of the ISA/US
 Mail Stop PCT, Attn: ISA/US, Commissioner for Patents
 P.O. Box 1450, Alexandria, Virginia 22313-1450
 Facsimile No. 571-273-3201

Authorized officer:
 Blaine R. Copenheaver

PCT Helpdesk: 571-272-4300
 PCT OSP: 571-272-7774