

(No Model.)

W. LASH.  
SLIDING DOOR LOCK.

No. 526,403.

Patented Sept. 25, 1894.

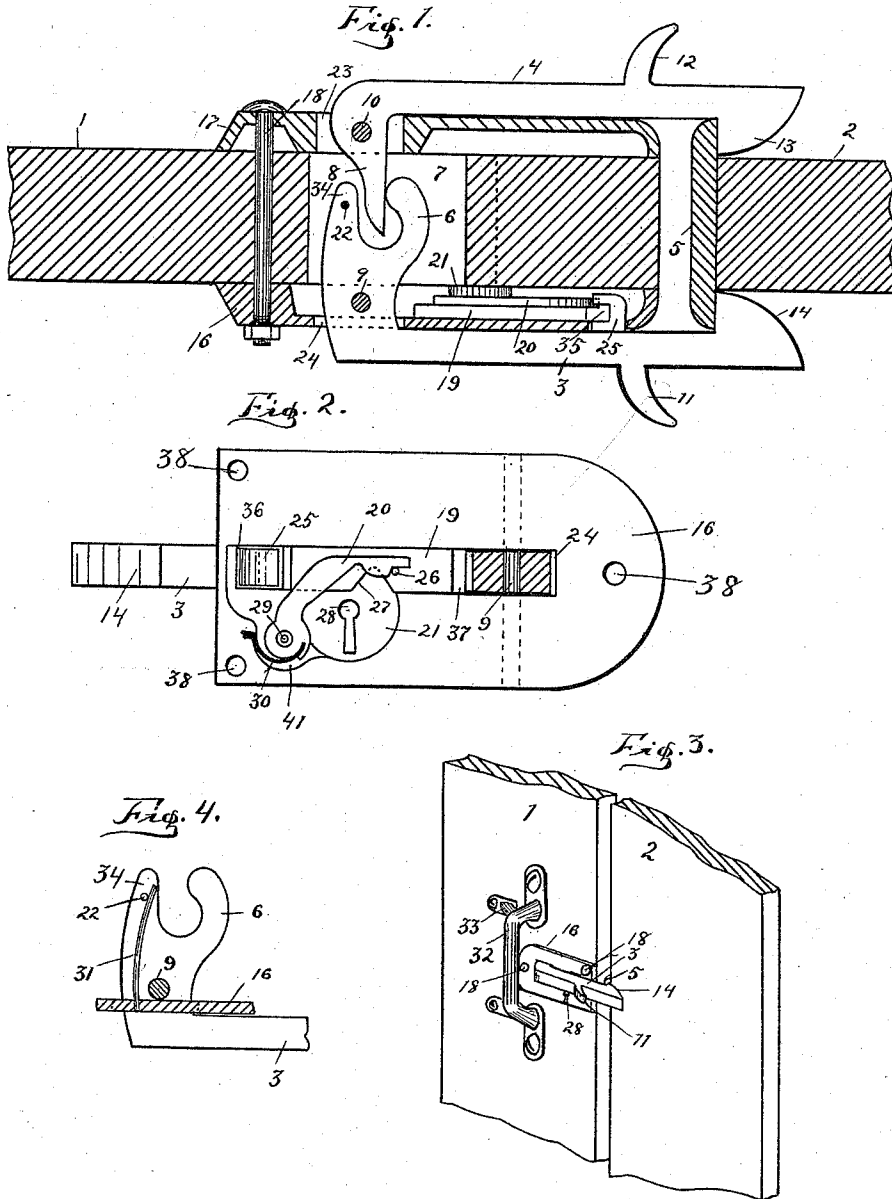

WITNESSES:

*Halter G. Burns*  
*William J. Rankin*

*William Lash* INVENTOR

BY *Chapin & Denny*  
*his* ATTORNEYS.

# UNITED STATES PATENT OFFICE.

WILLIAM LASH, OF AVILLA, INDIANA.

## SLIDING-DOOR LOCK.

SPECIFICATION forming part of Letters Patent No. 526,403, dated September 25, 1894.

Application filed May 28, 1894. Serial No. 512,645. (No model.)

### *To all whom it may concern:*

Be it known that I, WILLIAM LASH, a citizen of the United States, residing at Avilla, in the county of Noble, in the State of Indiana, have invented certain new and useful Improvements in a Combined Latch and Lock for Doors; and I do hereby declare that the following is a full, clear, and exact description of the invention, which will enable others skilled in the art to which it appertains to make and use the same, reference being had to the accompanying drawings, which form part of this specification.

My invention relates to improvements in combined latches and locks, specially designed for use on sliding and rolling doors.

The object of my improvement is to provide a cheap and simple combined latch and lock for sliding barn-doors, which is easily repaired and conveniently operated with equal facility from either side of the door, so constructed and arranged as to latch automatically upon both sides on closing the door and which can also be securely locked when desired.

My invention comprises two slotted plates adapted to be rigidly mounted upon opposite sides of the door, and each carrying a pivotally mounted latch, adapted for a locking engagement at their rear extremities, the said latches being held in a normal position by a retracting spring, one of the said plates being provided with a slidable locking-plate or bolt adapted for engagement with an inwardly projecting lug upon one of the said latches, and a spring-pressed holding-pawl adapted to be operated by a suitable key.

The novel feature of my invention consists in the construction and arrangement of the operating parts whereby the latches are adapted for an automatic locking engagement upon closing the door, and for a simultaneous disengagement by the operation of either of the said latches.

Similar figures of reference in the drawings indicate similar parts throughout the several views.

Figure 1 is a cross section of my invention in position upon a proper sliding door, show-

ing the general arrangement of the operative parts. Fig. 2 is an inside view of one of the inclosing plates showing the slidable locking-plate and the spring pressed holding-pawl. Fig. 3 is a perspective of my improvement in position upon a sliding door. Fig. 4 is a detail of the retracting spring by which the latches are held in position.

The door I on which my improvement is mounted is a sliding door, such as is in common use upon barns and other farm buildings, is movable to and from the jamb 2, Fig. 3, and is provided with proper handles 32 upon both sides thereof, laterally braced and strengthened by the oblique braces 33. The said door also has a transverse aperture or opening 7, of sufficient size to accommodate the engaging ends of the pivoted latches.

The plates 16 and 17 are alike in form and outline but differ somewhat in construction as will be hereinafter pointed out, and are rigidly secured to opposite sides of the said door by means of the bolts 18 in the perforations 38. The plate 16 has two transverse rectangular openings midway its sides. In the rear one, 24, the latch 3 is pivotally secured, while the forward opening 36 receives the slotted lug 25 of said latch. The said plate also has a longitudinal slot 37 on its inner face between the said openings 36 and 24 in which a slidable locking-plate or bolt 19 is loosely mounted, and also an irregular recess 21 adapted to permit the engagement of the key bit with the locking plate 19, and also an irregular recess 41 of less depth in which the holding pawl 20 with the retracting spring is mounted. The said plate is also provided with a proper key hole 28. The receiving plate 17 also has a key-hole directly opposite the one in the plate 16, and has a rectangular opening 23 in the rear end thereof in which the latch 4 is pivotally mounted. The said latch 3 has a lateral and forwardly projecting thumb lug 11 for releasing the same and has upon its forward end a rounded shoulder 14 adapted to automatically engage the cross-piece or lug 5 on the door jamb 2, and is provided upon its rear end with the bifurcated lug 6 integral therewith, arranged at right

angles with the body thereof, and is pivotally mounted in the opening 24 on the pin 9, and is adapted to engage a corresponding lug on the latch 4. The fork 34 of said lug has a pin 22 adapted to secure the free end of the retracting spring 31 hereinafter described. The latch 3 is also provided upon its inner face with the inwardly projecting lug 25 having a vertical slot 35 adapted to receive the slidable locking plate 19 when it is desired to lock the said latches. The latch 4 has a thumb-lug 12 and a rounded terminal shoulder 13 similar in construction and arrangement to the said lug 11 and the shoulder 14 respectively, but the rear end of the said latch 4 has a pointed and inwardly pointing integral lug 8 pivotally mounted in the opening 23 on the pin 10, arranged when in position between the forks of the said lug 6 and adapted for an interlocking engagement therewith for the purpose hereinafter described.

The said latches 3 and 4 are normally in a position parallel with the plates 16 and 17 respectively and resting against the outer surface thereof, and are retained in such position by the retracting spring 31 which has one end rigidly secured in the plate 16 and has its free end adapted to slidingly engage the pin 22 in the bifurcated lug 6, the said pin 22 being so arranged relative to the point at which the said spring is secured as to secure the proper tension thereof.

The slidable locking plate 19 loosely mounted in the longitudinal recess 37 of the plate 16, has upon its lower edge at or near the center of its length a  $\Lambda$  shaped slot against the sides of which the bit of the key engages in sliding the same, and also has a pin 26 which is engaged by the holding pawl 20. The irregularly shaped and obliquely pointing pawl 20 is loosely mounted on a pivot 29 in the recess 41 of the said plate 16, and has a retracting spring 30 rigidly mounted in a proper slot or perforation in the base thereof, and having its free end slidingly mounted in a proper slit in the said plate, and has a proper tension to secure reliable action of the said pawl. The said pawl 20 has its free end shouldered and is adapted to engage the pin 26 and thus normally hold the said locking plate out of engagement with the slotted lug 25.

The manner of operating my invention thus described is obvious and briefly stated is as follows: The operator can readily open the door 1 from either side thereof by pulling outwardly upon the corresponding lugs 11 or 12, for pulling outwardly the forward end of the latch 3 will also force outwardly in the same manner the forward end of the latch 4, by the bearing of the lug 34 against the said lug 8, and upon releasing his hold upon the lug 11 the latch 3 will resume its normal position under the influence of the retracting spring 31, and in its return movement will carry with it the latch 4 by its engagement with the lug 8. In

like manner withdrawing the latch 4 from its engagement with the lug 5, will simultaneously release the said latch 3 from its engagement under the influence of the lug 8 upon the forward fork of the bifurcated lug 6. When it is desired to lock the said latches a proper key is placed in the key hole 28 upon either side of the door and turned rearwardly until the bit thereof engages the shoulder on the forward end of the pawl 20, and thereby elevates the same sufficiently to let the pin 26 pass the said shoulder, as seen in Fig. 2, when by the engagement of the said key bit with the said locking-plate 19 in the slot 27, the said locking-plate is forced into a locked engagement with the said slotted lug 25 thereby securely locking both latches 3 and 4. It is obvious from the rounded form of the shoulders on the forward ends of the said latches that when the door 1 is closed, the said latches will engage the lug 5 automatically. It is also obvious that my improved latch can be constructed and used without the addition of the herein described lock in which case the slotted lug 25 on the latch 3 and the slot 36 of the plate 16 are both omitted.

Having thus described my invention and the manner in which the same is employed, what I desire to secure by Letters Patent, is—

1. A combined latch and lock consisting of the plates 16 and 17 rigidly mounted upon opposite sides of the door, as shown, the said door having a lateral opening for the interlocking ends of the latches, the said plate 16 having the lateral openings 24 and 36 for the purpose specified, a longitudinal recess 37 for the locking-plate, a slidable locking plate 19 having a holding pin 26, and provided with a spring pressed pawl 20 adapted to hold the said locking-plate in position by engaging the said pin, the said plate 17 having a lateral opening 23 for the pivoted end of the latch 4, the latch 3 pivotally mounted in the opening 24 of the plate 16, having a thumb lug 11, a shoulder 14 for engaging the lug 5, a slotted lug 25 for receiving the said plate 19, and a bifurcated lug 6 for engaging the latch 4, as shown, a latch 4 pivotally mounted in the opening 23 of the plate 17, having a thumb lug 12, a shoulder 13 for engaging the lug 5 and a pointed lug 8 on the rear end thereof to engage the said lug 6, all substantially as described.

2. A door latch comprising the slotted plates 16 and 17 rigidly mounted upon a proper door and having the openings 24 and 23 respectively for the pivoted latches, the latch 3 pivotally mounted in the opening 24 of the plate 16, as shown, having a thumb lug 11, a shoulder 14 on the forward end thereof for engaging the lug 5 and an inwardly projecting bifurcated lug 6 adapted to engage the latch 4, as described, and a latch 4 pivotally mounted in the opening 23 of the plate 17, having a thumb-lug 12, a terminal shoulder

13 on its forward extremity, and provided  
upon its rear end with an inwardly project-  
ing lug 8 adapted to form an interlocking  
engagement with the said lug 6 in a proper  
5 later opening in the said door, the said latches  
being actuated by a retracting spring as  
shown, all substantially as described.

Signed by me, at Avilla, Noble county, In-  
diana, this 23d day of May, A. D. 1894.

WILLIAM LASH.

Witnesses:

JOHN ARNAN,  
ANDREW LASH.