

July 17, 1951

M. J. FERGUSON

2,560,761

MERCHANDISE DISPLAY DEVICE AND/OR PACKAGE

Filed Sept. 16, 1946

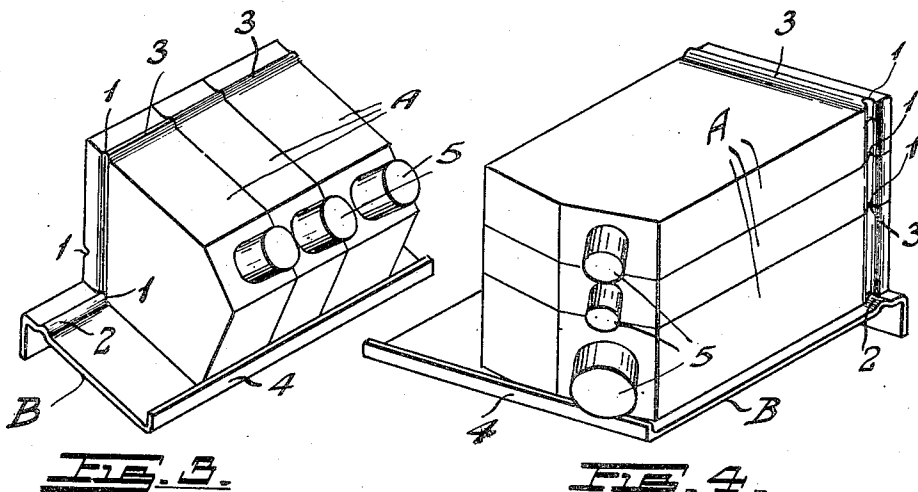
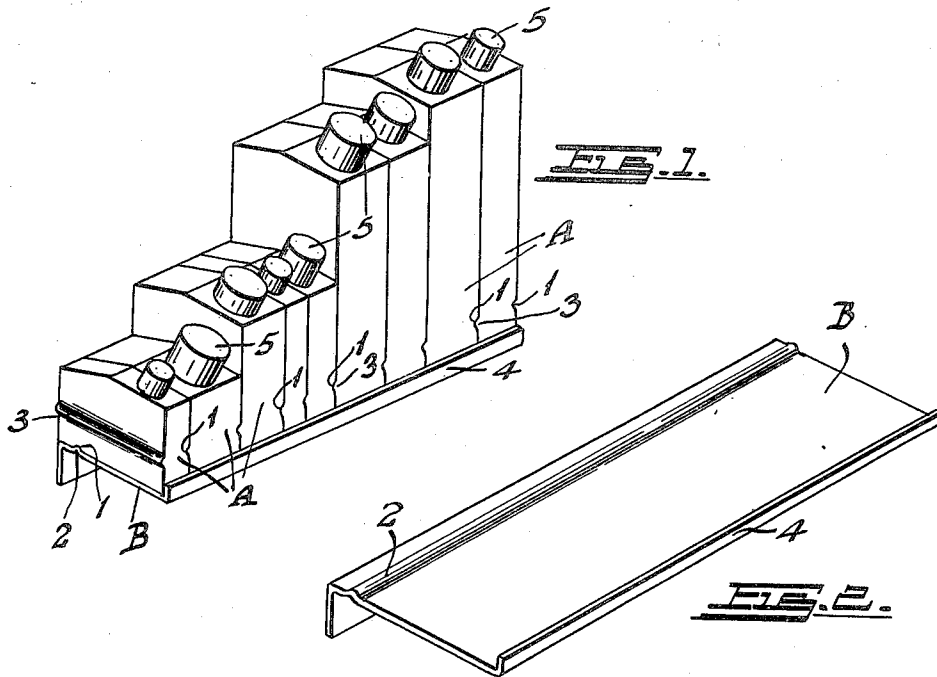

INVENTOR,
MARTIN J. FERGUSON
By *Smart & Biggar*
ATTORNEYS.

UNITED STATES PATENT OFFICE

2,560,761

MERCHANDISE DISPLAY DEVICE AND/OR PACKAGE

Martin J. Ferguson, Swansea, Ontario, Canada

Application September 16, 1946, Serial No. 697,186
In Canada July 25, 1946

4 Claims. (Cl. 220-23.4)

1

This invention relates to packages of containers and/or display devices for merchandise in containers.

A great variety of forms of such devices or packages have from time to time been proposed but none of them combines the advantages of an article embodying my invention. Such an article is particularly adapted for adoption by a manufacturer or distributor concerned with the sale of a variety of articles or preparations adapted to be packaged and/or displayed together in containers of the same size or of somewhat varying sizes either as samples to be exhibited by a travelling salesman or in a shop by which the manufacturer's or distributor's line is carried.

My invention consists in a shelf or series of shelves having a holding rib adapted to maintain in position relatively to it and to each other a series of containers, preferably of rectangular shape, each container having a groove in one or more surfaces adapted to co-operate with the rib on the shelf or shelves. The containers may also have ribs and grooves adapted to co-operate with corresponding grooves and ribs on adjoining containers so that the containers are firmly held in appropriate relation to one another for carriage and display purposes and the shelf may also have a flange in front to retain the containers thereon. Whether the containers are constructed with or without ribs and grooves co-operating with grooves and ribs or other containers, the co-operation of their grooves with a rib on a shelf makes the combination of the containers with the shelf or shelves particularly adapted for the packaging and carriage of the series of containers and for their display as samples or on the premises of a dealer as does also the flange at the front of the shelf.

In the drawings

Figure 1 is a perspective view showing a series of containers of different sizes in place on a shelf.

Figure 2 is a perspective view of the shelf.

Figures 3 and 4 show alternative arrangements of the containers on a shelf.

In the embodiment of my invention shown in the figures rectangular containers A have a groove 1 on three sides adapted to co-operate with a rib 2 on the shelf B so that the containers can be arranged on the shelf with a groove and the shelf rib co-operating in any of the three positions shown in Figures 1, 3 and 4 for carriage or display and with discharge openings 5 appropriately placed having regard to the position occupied by the containers. The shelf may have

2

a flange 4 and the containers may each have also on one side a rib 3 adapted to co-operate with the groove 1 on one side of an adjoining container in which case the containers may be positioned and held in place as shown in Figures 1 and 3 or held together as shown in Figure 4.

Even without a flange on the shelf or ribs on the containers adapted to co-operate with adjoining containers and with only one ribbed shelf the combination of the shelf and containers can be readily packaged in an appropriate carton in readiness for display particularly if the containers are of such dimensions as to fit the shelf longitudinally and the carton vertically or vice versa, but even if the containers are not so sized they can for the purposes of packaging be readily held in place both longitudinally and vertically by appropriate wedges or the like of waste material.

The device may include only one shelf as shown in the drawings, or a series of shelves one above the other and when it is desired to remove any given container it may, if the containers do not co-operate with one another, be readily lifted from the shelf, and if they do so co-operate can be removed by sliding one or more containers slightly along the shelf rib.

I claim:

1. In the shelf mounting of articles having an end wall and side walls terminating at said end wall, a construction for retaining said articles against displacement transversely of the shelf and against displacement in at least one direction relative to each other, comprising a longitudinal, upwardly extending rib on said shelf, groove means on the end wall of each article for receiving said rib, groove means on one and the same side wall of each of said articles, and a parallel rib complementary to said side wall groove means and located on the opposite side wall of each article at a location corresponding to the location of said side wall groove means, whereby, when said articles are mounted on said shelf with said shelf rib and the end wall groove means in mating relation, said side wall ribs and groove means of adjacent articles mate to prevent displacement of adjacent articles relative to each other away from the shelf, while the mating of said shelf rib and end wall groove means prevents displacement of the articles transversely of the shelf.

2. A construction as set forth in claim 1, said side and end wall groove means and said side wall rib means of each article each being con-

3

tinuous and each extending entirely across the wall on which it is formed.

3. A construction as set forth in claim 1, wherein said side wall rib and groove means extend transversely of the end wall groove means.

4. A construction as set forth in claim 1 wherein said articles have at least four of said side walls, each opposite pair or side walls of each container having said complementary rib and groove means configuration, said side wall ribs and groove means all being equally spaced from the end wall of each container, the end wall groove means and the side wall groove means being substantially identical in cross section to permit disposition of said articles with the same, grooved side wall of each article in contact with the shelf and with the groove means of that side wall mating with the shelf rib, such disposition of the articles placing the rib and groove means

4

of the vertically extending side walls in mating engagement.

MARTIN J. FERGUSON.

REFERENCES CITED

The following references are of record in the file of this patent:

UNITED STATES PATENTS

Number	Name	Date
Re. 17,204	Johnson	Feb. 5, 1929
353,600	Sloan	Nov. 30, 1886
454,772	Sagar	June 23, 1891
1,112,943	Stone	Oct. 6, 1914
2,064,518	Brogden	Dec. 15, 1936

FOREIGN PATENTS

Number	Country	Date
529,357	Germany	July 11, 1931