



US 20160242552A1

(19) **United States**

(12) **Patent Application Publication**  
**MAKOS et al.**

(10) **Pub. No.: US 2016/0242552 A1**

(43) **Pub. Date: Aug. 25, 2016**

(54) **SEATING DEVICE WITH STORAGE**

*A47C 3/20* (2006.01)

(71) Applicant: **Plano Molding Company**, Plano, IL (US)

*A47C 4/02* (2006.01)

*A47C 1/14* (2006.01)

*A47C 4/04* (2006.01)

(72) Inventors: **Timothy S. MAKOS**, West Bend, WI (US); **Ryan J. Kleckner**, Grafton, WI (US)

(52) **U.S. Cl.**

CPC . *A47C 7/002* (2013.01); *A47C 1/14* (2013.01);

*A47C 4/04* (2013.01); *A47C 3/20* (2013.01);

*A47C 4/021* (2013.01); *B65D 51/24* (2013.01)

(21) Appl. No.: **15/019,407**

(22) Filed: **Feb. 9, 2016**

**Related U.S. Application Data**

(60) Provisional application No. 62/119,553, filed on Feb. 23, 2015.

**Publication Classification**

(51) **Int. Cl.**

*A47C 7/00* (2006.01)

*B65D 51/24* (2006.01)

(57) **ABSTRACT**

A seat storage assembly includes a seating unit to support a user. The seat storage assembly includes a storage unit including a storage space, and a rail system that mounts to the storage unit. The rail system includes a first rail having a first sliding slot, and a second rail having a second sliding slot and extending in parallel with the first rail.

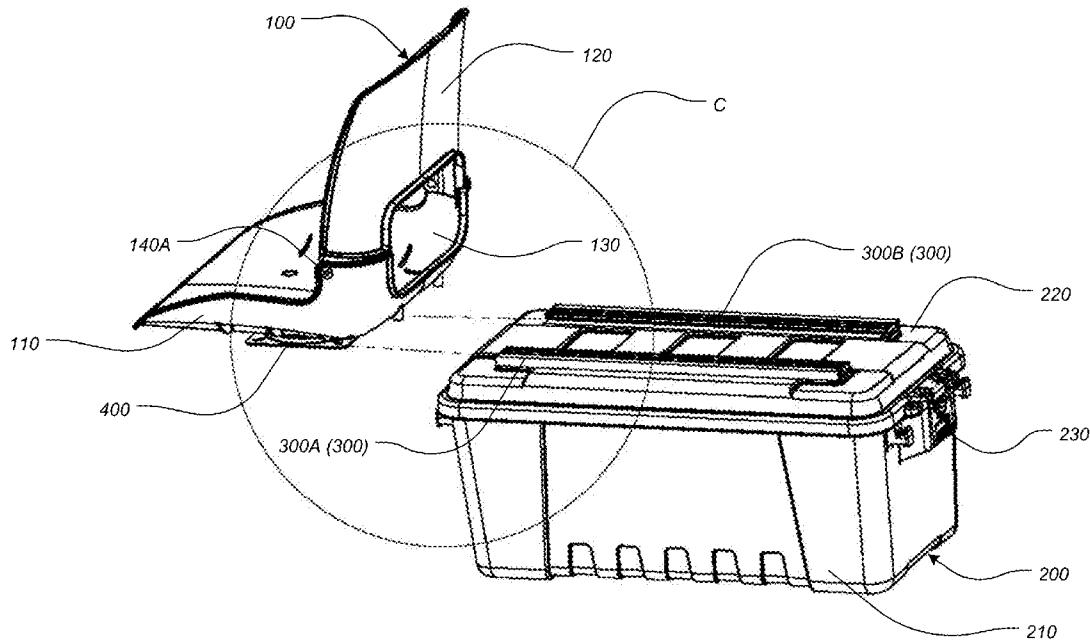

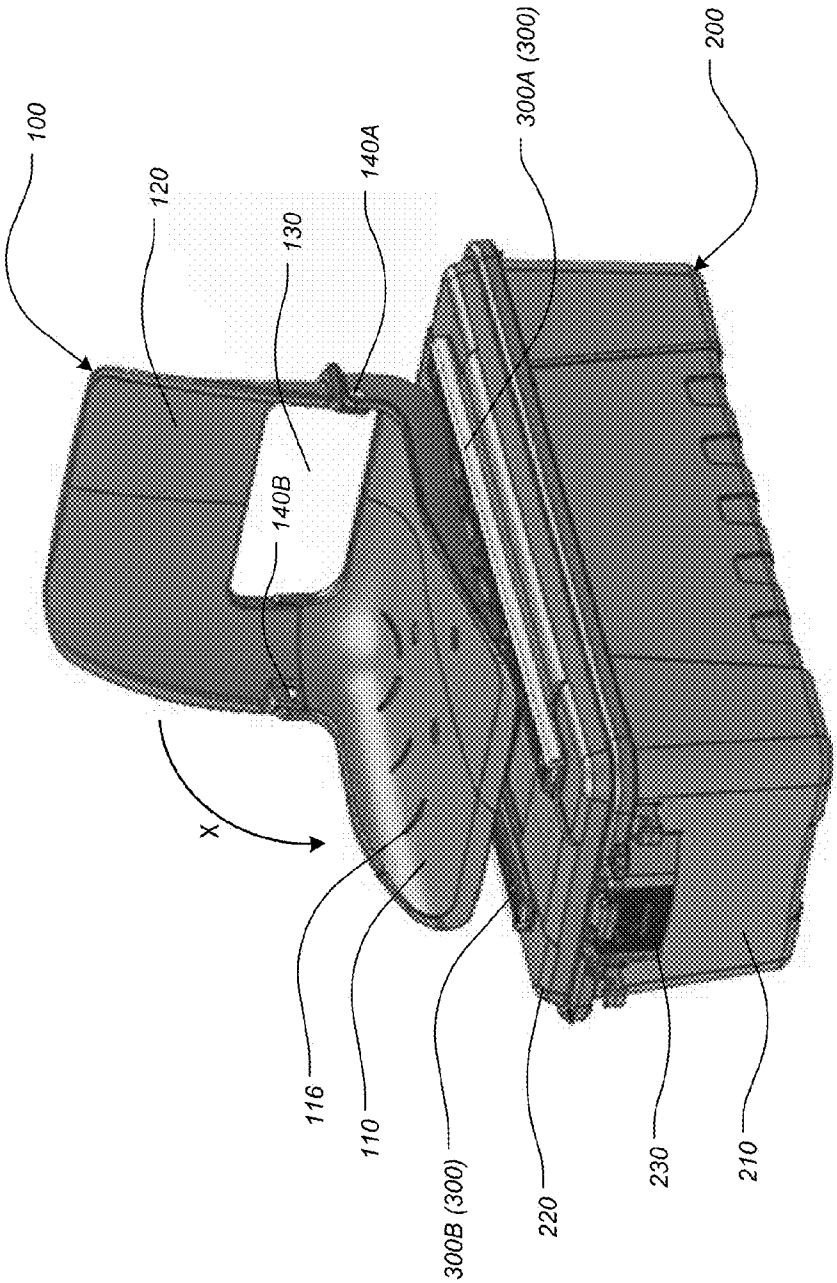

**FIG. 1**



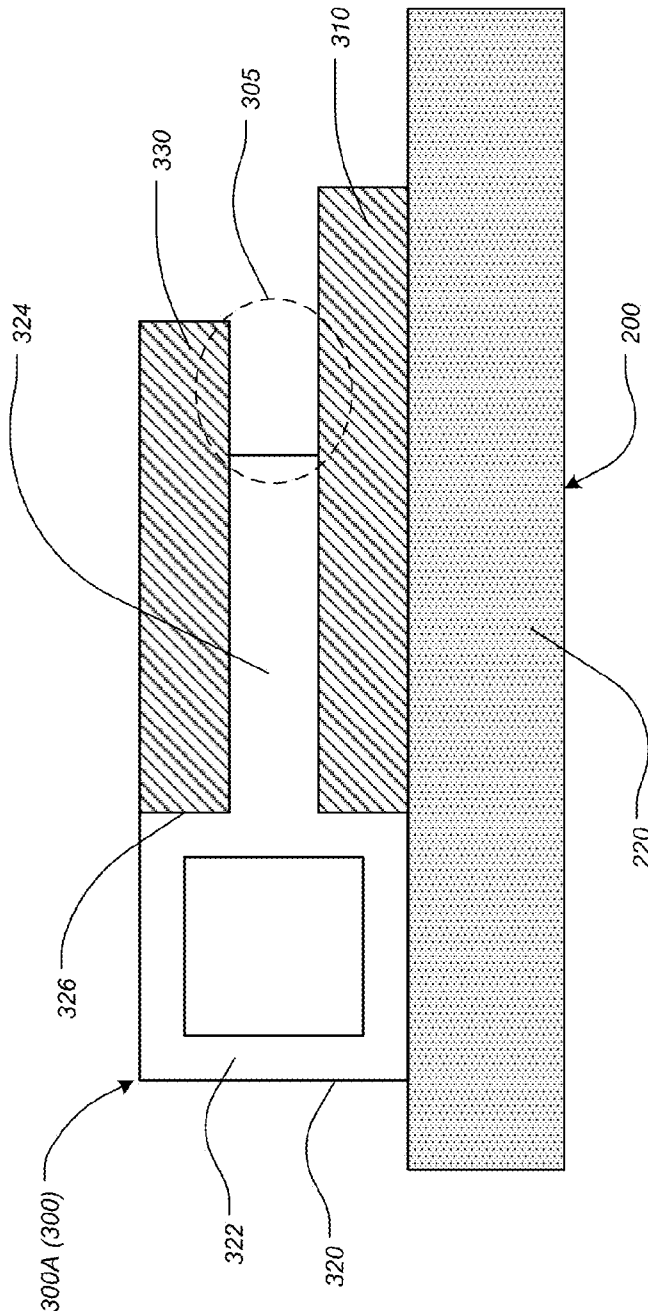

**FIG. 3**

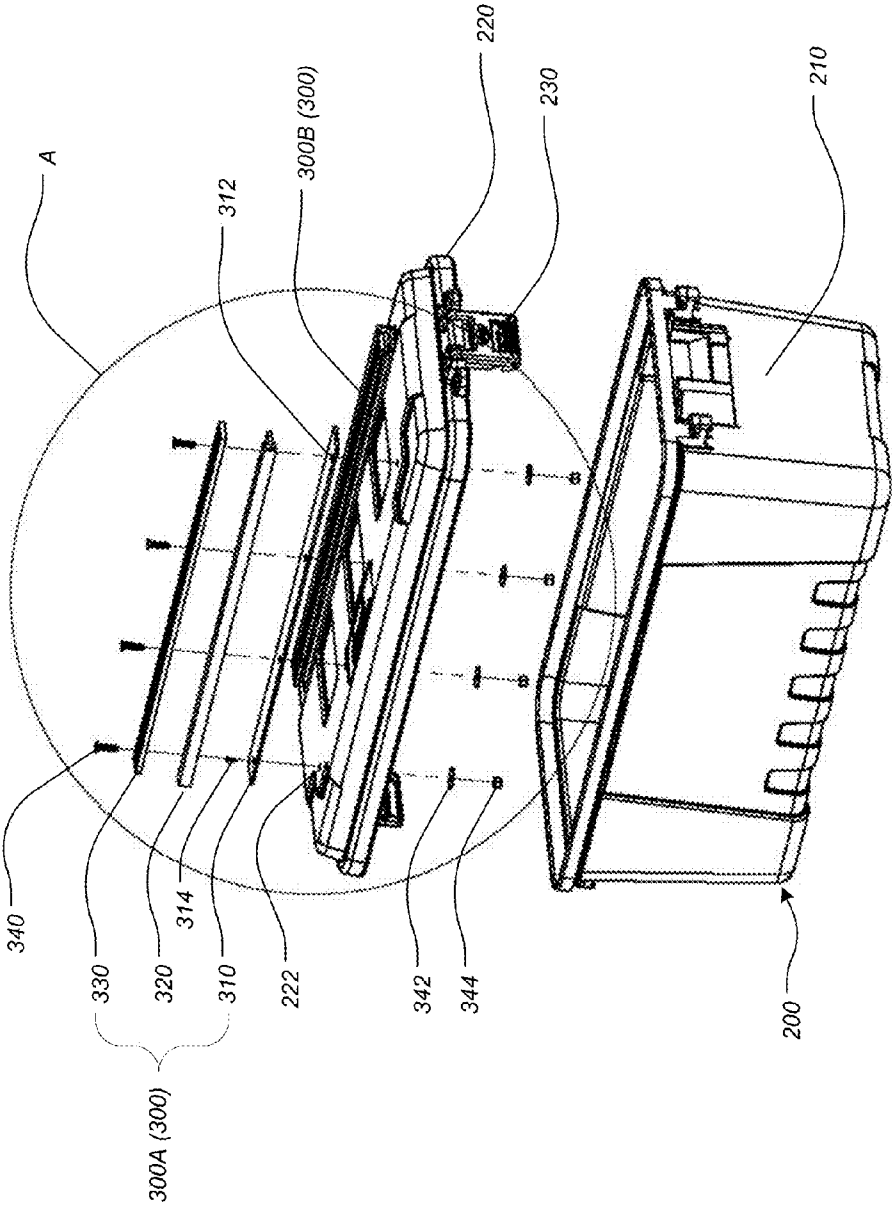

FIG. 4A

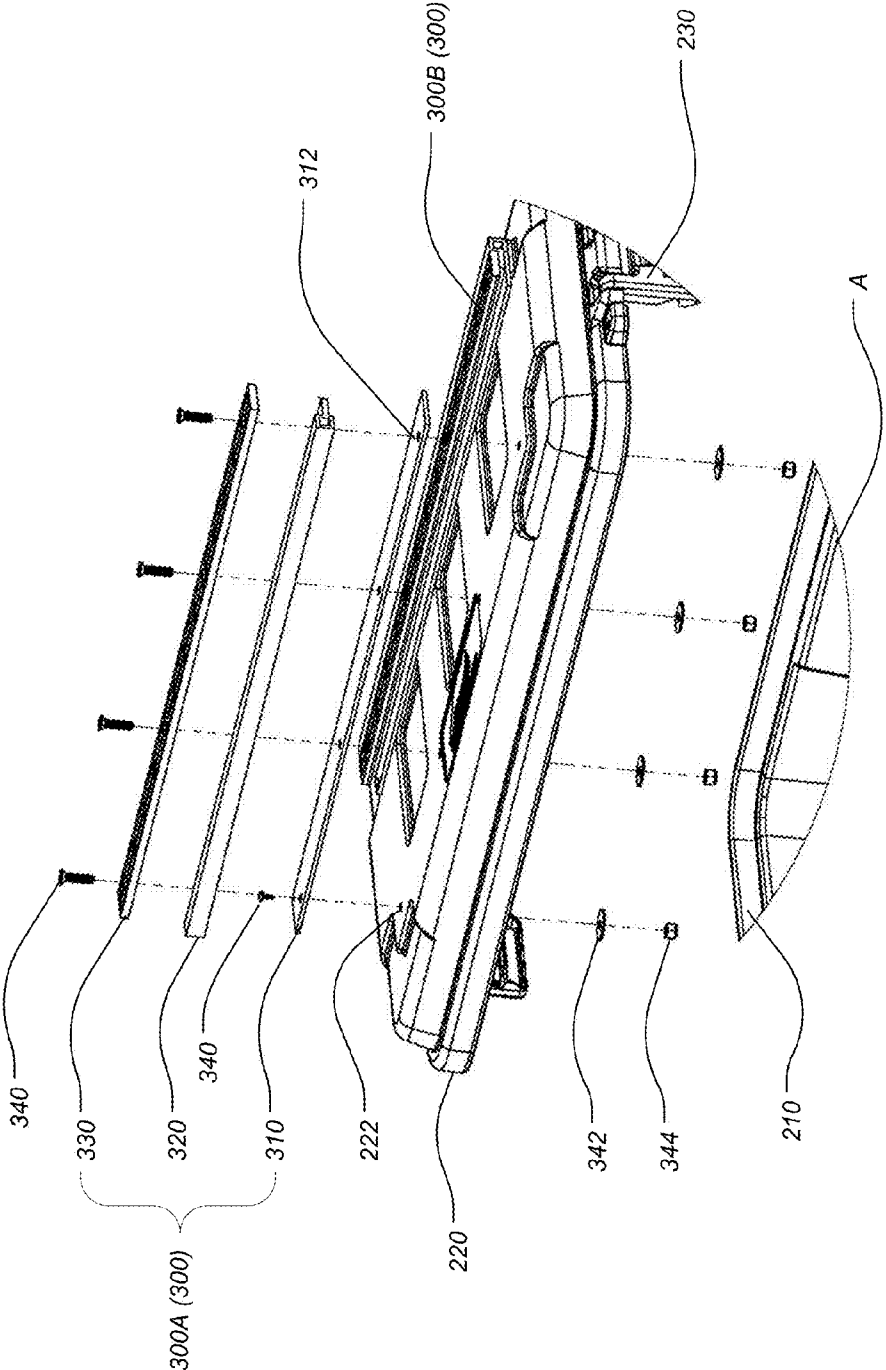
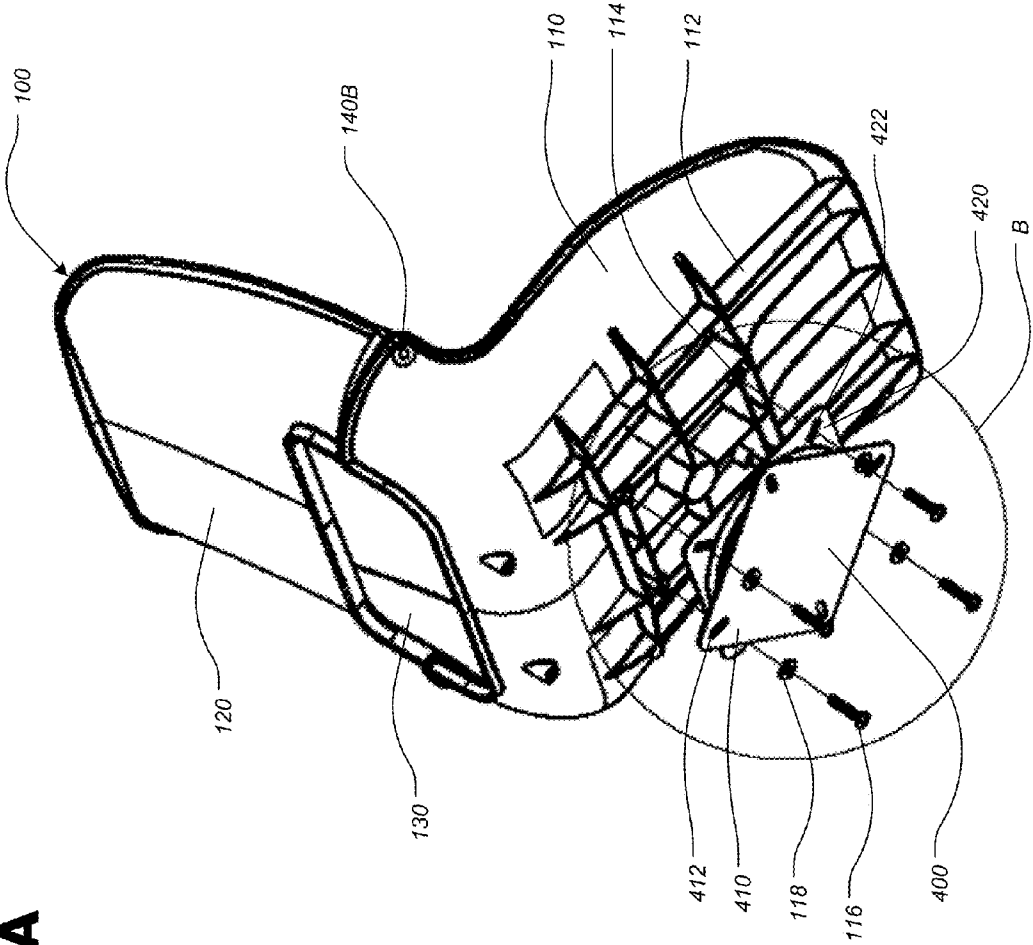

FIG. 4B



**FIG. 6A**



**FIG. 6B**

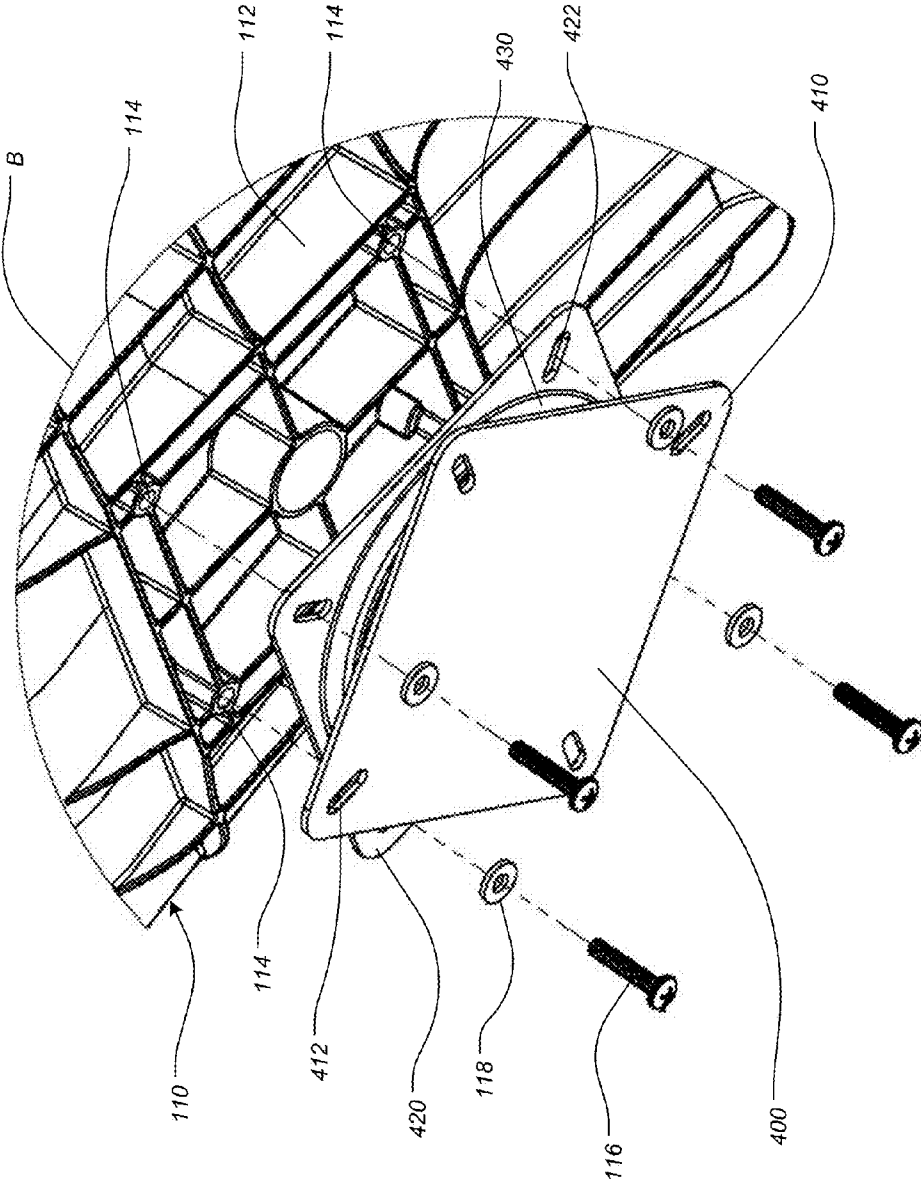

10

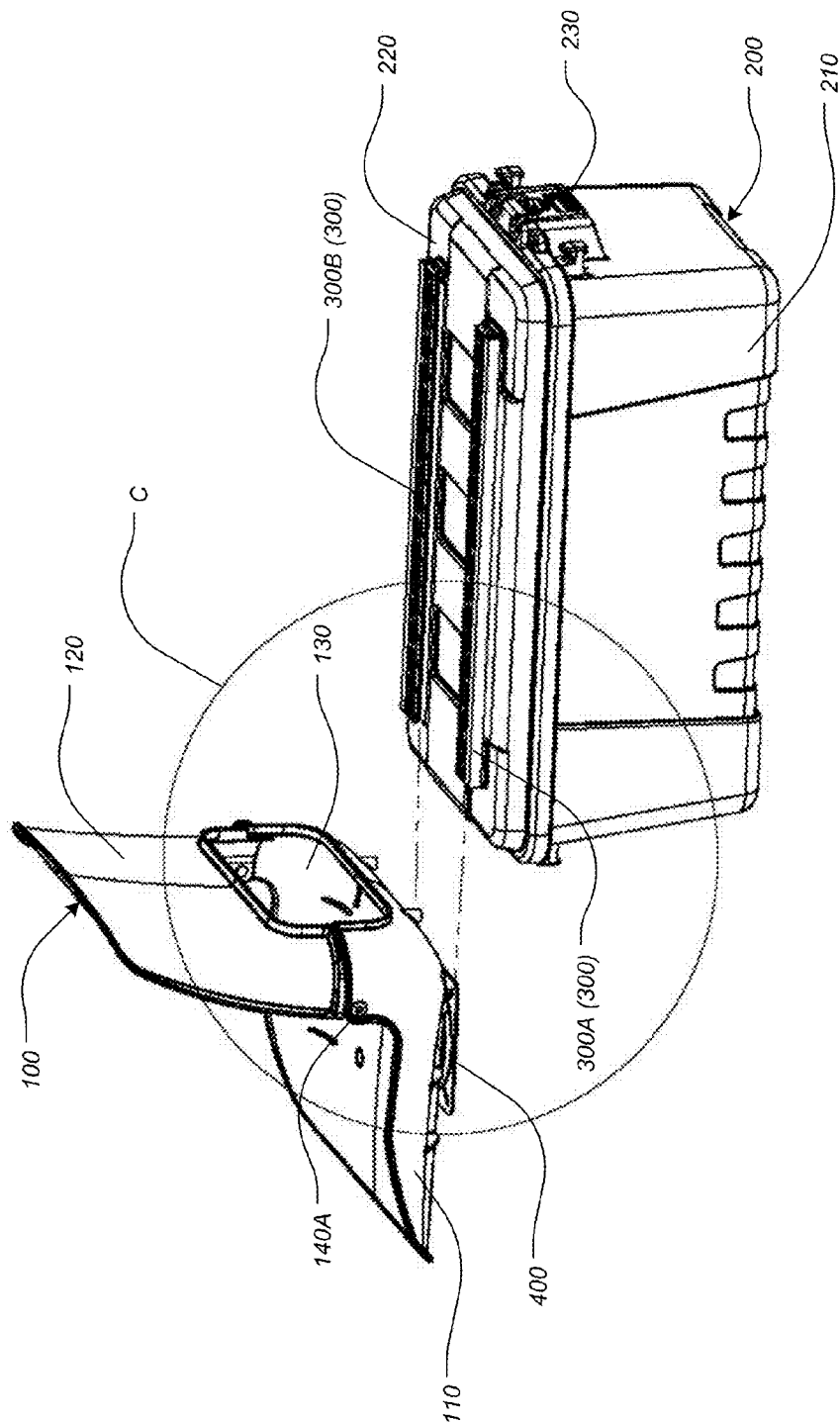

**FIG. 7A**

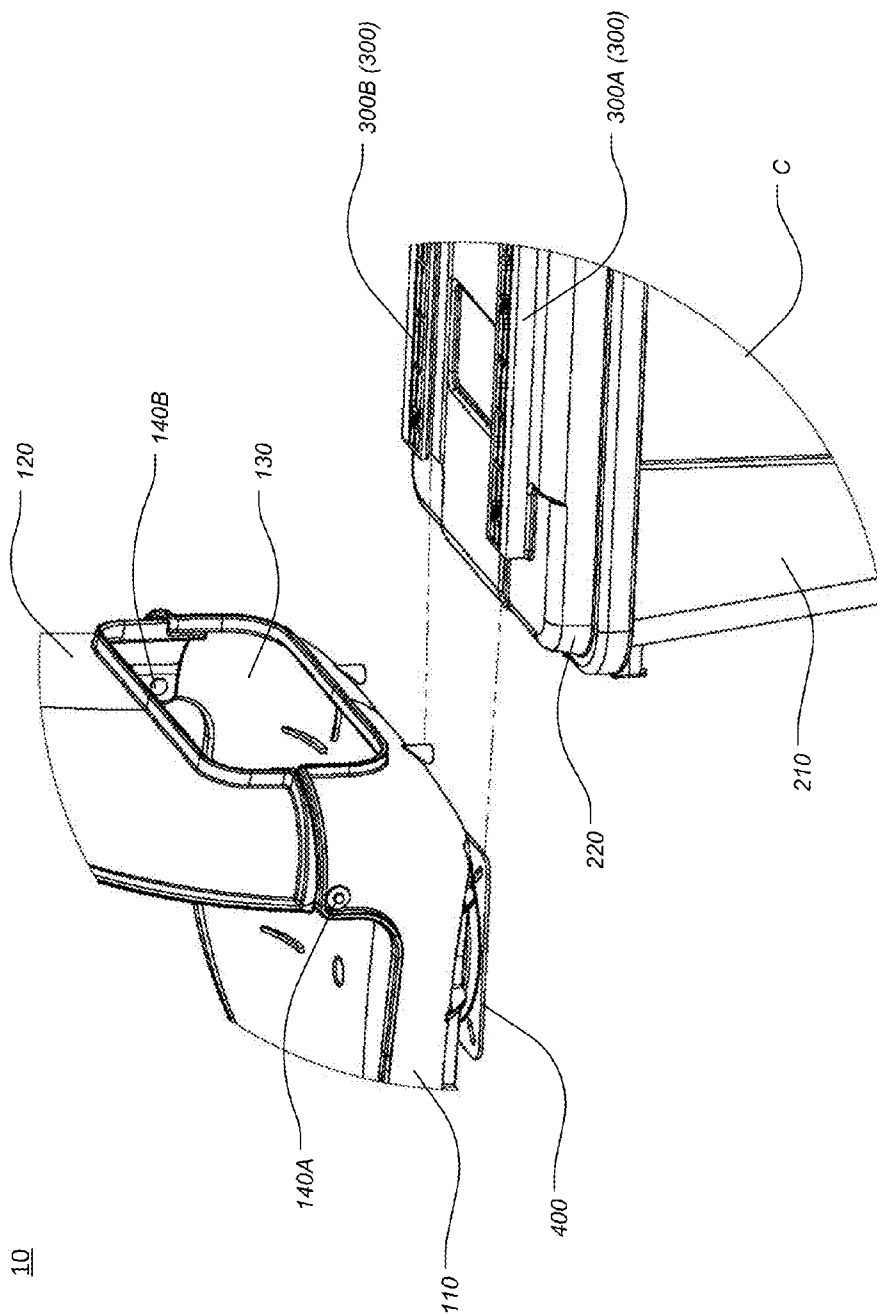

**FIG. 7B**

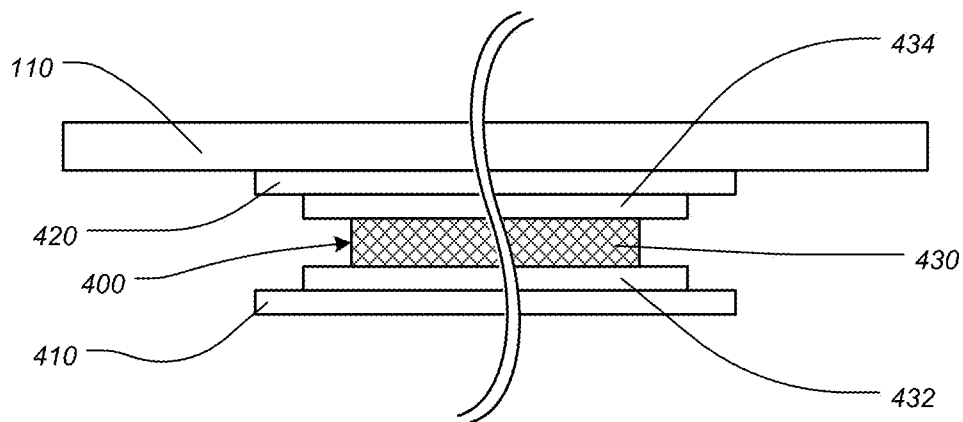

**FIG. 8A**

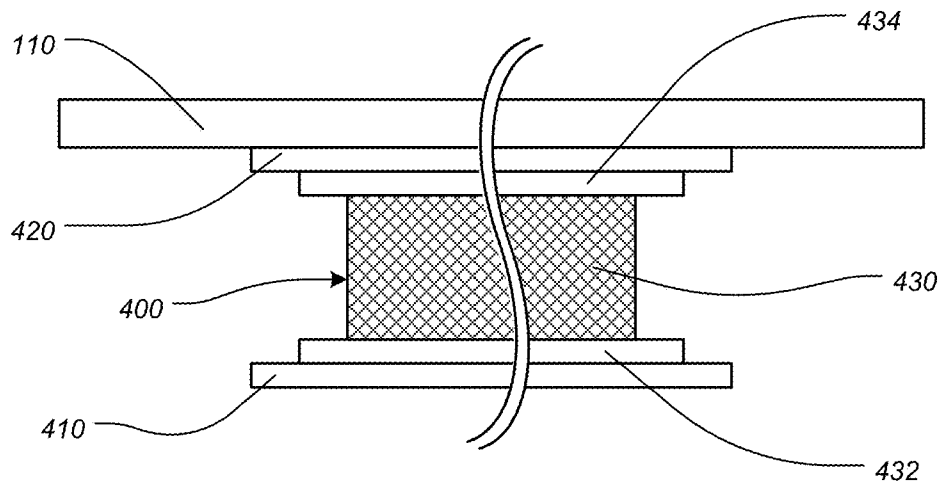

**FIG. 8B**

**SEATING DEVICE WITH STORAGE**

**CROSS REFERENCE TO PRIOR APPLICATIONS**

[0001] This application claims priority to and the benefit thereof from U.S. Provisional Patent Application No. 62/119, 553 filed on Feb. 23, 2015, titled "Seat On Storage Trunk," the entirety of which is hereby incorporated herein by reference.

**FIELD OF THE DISCLOSURE**

[0002] The present disclosure relates generally to a seating device for outdoor and/or recreational activities, and more specifically it relates to a seating device having a storage space.

**BACKGROUND OF THE DISCLOSURE**

[0003] Seating devices are used in outdoor/recreational activities, such as, for example, ice fishing, open water fishing, hunting, and the like. Similar to conventional chairs, those devices include a horizontal panel combined with a frame or legs to position the horizontal panel to a comfortable seating height. Those seating devices, however, are not equipped with many useful functionalities for outdoor activities, except for a few basic features such as foldability. Accordingly, there exists an unfulfilled need for a seating device that may provide various useful features for outdoor/recreational activities.

**SUMMARY OF THE DISCLOSURE**

[0004] One aspect of the present disclosure provides a seat storage assembly including a seating unit to support a user. The seat storage assembly includes a storage unit including a storage space, and a rail system that mounts to the storage unit. The rail system includes a first rail having a first sliding slot, and a second rail having a second sliding slot and extending in parallel with the first rail.

[0005] The storage unit may include a main body surrounding the storage space and have an opening exposing the storage space, and a lid covering the opening of the main body. The rail system may be affixed to an upper surface of the lid.

[0006] The seat storage assembly may further include a base that engages the rail system and supports the seating unit. The base may include a lower panel movable along the first sliding slot and the second sliding slot, an upper panel affixed to the seating unit; and a neck coupled between the lower panel and the upper panel. The neck may allow the upper panel to rotate independently from an orientation of the lower panel.

[0007] Each of the first rail and the second rail may include a bottom plate that attaches to the storage unit, a center frame having a head portion and a leg portion extending laterally from a sidewall of the head portion, and a top plate that attaches to the bottom plate with the leg portion of the center frame sandwiched therebetween. The bottom plate and the top plate may be wider than the leg portion of the center frame and in contact with the sidewall of the head portion.

[0008] Each of the first sliding slot and the second sliding slot may be located laterally adjacent to the leg portion of the center frame and between the bottom plate and the top plate.

[0009] The seating unit may include a horizontal portion mounted on the upper panel of the base and vertically supporting a user in a seating position, and a vertical portion connected to the horizontal portion and laterally supporting a back of the user in the seating position.

[0010] The seating unit may further include a reinforcement pattern formed on a bottom surface of the horizontal portion. The upper panel of the base may attach to the reinforcement pattern.

[0011] The seating unit may be foldable. The seating unit may include a pivot joint coupled between the horizontal portion and the vertical portion. The base may be height-adjustable.

[0012] According to another aspect of the disclosure, a seat storage assembly includes a storage unit including a storage space for holding an item, a rail system that attaches to the storage unit, and a seating unit that attaches to the rail system.

[0013] The seat storage assembly may further include a base that attaches to the rail system. The base may include a lower panel coupled to the rail system, an upper panel coupled to the seating unit, and a neck coupled between the lower panel and the upper panel. The neck may allow the upper panel to move independently from an orientation of the lower panel.

[0014] The rail system may include a first rail having a first sliding slot, and a second rail having a second sliding slot and extending in parallel with the first rail.

[0015] The seating unit may be foldable. The base may be height-adjustable.

[0016] According to yet another aspect of the disclosure, a seat storage assembly includes a storage unit that has a storage space and a lid, a rail system that attaches to the lid of the storage unit and includes a rail having a sliding slot, and a base that engages the rail system.

[0017] The rail may attach to the lid along a longitudinal direction of the storage unit.

[0018] The seat storage assembly may further include a seating unit that attaches to the base. The seating unit may include a first portion that supports the user in a first direction in the seating position, and a second portion that supports a back of the user in a second direction in the seating position.

[0019] The base may be height-adjustable. The rail system may include another rail that engages the base.

[0020] Additional features, advantages, and embodiments of the disclosure may be set forth or apparent from consideration of the following detailed description, drawings, and claims. Moreover, it is to be understood that both the foregoing summary of the disclosure and the following detailed description are exemplary and intended to provide further explanation without limiting the scope of the disclosure as claimed.

**BRIEF DESCRIPTION OF THE DRAWINGS**

[0021] The accompanying drawings, which are included to provide a further understanding of the disclosure, are incorporated in and constitute a part of this specification, illustrate embodiments of the disclosure and together with the detailed description serve to explain the principles of the disclosure. No attempt is made to show structural details of the disclosure in more detail than may be necessary for a fundamental understanding of the disclosure and the various ways in which it may be practiced. In the drawings:

[0022] FIG. 1 shows a perspective view of an example of a seat storage assembly, which is constructed according to the principles of the disclosure.

[0023] FIG. 2 shows another perspective view of the seat storage assembly without a seating unit.

[0024] FIG. 3 shows a partial cross-sectional view of an example of a rail of the seat storage assembly.

**[0025]** FIG. 4A shows an exploded side perspective view of a storage unit and a rail system of the seat storage assembly.

**[0026]** FIG. 4B shows an enlarged exploded side perspective view of a portion of the storage unit and rail system shown in FIG. 4A, indicated by circle A.

**[0027]** FIG. 5 shows a partial cross-sectional view of the rail and a swivel base of the seat storage assembly.

**[0028]** FIG. 6A shows a bottom perspective view of a seating unit and the swivel base of the seat storage assembly.

**[0029]** FIG. 6B shows an enlarged bottom perspective view of a portion of the seat storage assembly shown in FIG. 6A, indicated by circle B.

**[0030]** FIG. 7A shows a side perspective view of the storage unit and the seating unit of the seat storage assembly.

**[0031]** FIG. 7B shows an enlarged side perspective view of a portion of the seat storage assembly shown in FIG. 7A, indicated by circle C.

**[0032]** FIG. 8A shows a side view of the swivel base adjusted to have a minimum height.

**[0033]** FIG. 8B shows another side view of the swivel base adjusted to have a maximum height.

#### DETAILED DESCRIPTION OF THE DISCLOSURE

**[0034]** The disclosure and the various features and advantageous details thereof are explained more fully with reference to the non-limiting embodiments and examples that are described and/or illustrated in the accompanying drawings and detailed in the following description. It should be noted that the features illustrated in the drawings are not necessarily drawn to scale, and features of one embodiment may be employed with other embodiments as the skilled artisan would recognize, even if not explicitly stated herein. Descriptions of well-known components and processing techniques may be omitted so as to not unnecessarily obscure the embodiments of the disclosure. The examples used herein are intended merely to facilitate an understanding of ways in which the disclosure may be practiced and to further enable those of skill in the art to practice the embodiments of the disclosure. Accordingly, the examples and embodiments herein should not be construed as limiting the scope of the disclosure. Moreover, it is noted that like reference numerals represent similar parts throughout the several views of the drawings.

**[0035]** The terms “including,” “comprising” and variations thereof, as used in this disclosure, mean “including, but not limited to,” unless expressly specified otherwise.

**[0036]** The terms “a,” “an,” and “the,” as used in this disclosure, means “one or more”, unless expressly specified otherwise.

**[0037]** Devices that are in communication with each other need not be in continuous communication with each other, unless expressly specified otherwise. In addition, devices that are in communication with each other may communicate directly or indirectly through one or more intermediaries.

**[0038]** Although process steps, method steps, or the like, may be described in a sequential order, such processes and methods may be configured to work in alternate orders. In other words, any sequence or order of steps that may be described does not necessarily indicate a requirement that the steps be performed in that order. The steps of the processes or methods described herein may be performed in any order practical. Further, some steps may be performed simultaneously.

**[0039]** When a single device or article is described herein, it will be readily apparent that more than one device or article may be used in place of a single device or article. Similarly, where more than one device or article is described herein, it will be readily apparent that a single device or article may be used in place of the more than one device or article. The functionality or the features of a device may be alternatively embodied by one or more other devices which are not explicitly described as having such functionality or features.

**[0040]** FIG. 1 shows a perspective view of an example of a seat storage assembly 10, which is constructed according to the principles of the disclosure. The assembly 10 may include a seating unit 100, a storage unit 200, and the like. The seating unit 100 may be slidably movable and rotatable with respect to the storage unit 200. The seating unit 100 may be configured to pivot with respect to the storage unit 200. Also, the assembly 10 may be configured such that a height of the seating unit 100 may be adjusted.

**[0041]** The seating unit 100 may include a first seat portion 110, a second seat portion 120, and the like. The first seat portion 110 may be substantially horizontal and constructed to vertically support a user in a seating position. The second seat portion 120 may be substantially vertical and constructed to horizontally support a back of the user in the seating position. The seating unit 110 may support the user in an orthonea position, in a fowler position, or the like.

**[0042]** The seating unit 100 may be foldable, which may be useful especially when being transported or stored. For example, the first seat portion 110 and the second seat portion 120 may be connected via pivot joints 140A, 140B. When pushed from behind (or pulled from the front), the second portion 120 may pivotally move in a direction shown by arrow X and may rest over the first seating portion 110. Optionally, the seating unit 100 may include a spring mechanism (not shown) that may be biased to fold the second seat portion 120 atop the first seat portion 110, or to unfold the second seat portion 120 into a seating configuration as seen in FIG. 1.

**[0043]** The seating unit 100 may include a plurality of openings for ventilation, draining liquid, and the like. For example, a large opening 130 may be formed between the first seat portion 110 and the second seat portion 120 to cool the user's lower back. The first seat portion 110 may include a plurality of openings 116 to cool the user's lower body.

**[0044]** The storage unit 200 may include a main body 210, a lid 220 and the like. The main body 210 may have a bottom wall and a plurality of sidewalls that form an inner storage space for holding one or more items. An opening exposing the inner storage space may be formed at an upper portion of the main body 210, which may be covered by the lid 220. The lid 220 may be removably attached to the main body 210. The lid 220 may be pivotally or slidably attached to the main body 210, so as to allow access to the inner storage by sliding or pivoting the lid 220 with respect to the main body 210. The main body 210 may include one or more fasteners 230 to keep the storage unit 200 closed.

**[0045]** FIG. 2 shows the assembly 10 without the seating unit 100. Referring to FIGS. 1 and 2, the assembly 10 may include a rail system 300, a swivel base 400, and the like, which may allow the seating unit 100 to slidably move and swivel over the storage unit 200. The rail system 300 may include a pair of rails 300A, 300B, which may be formed on or attached to an upper surface of the lid 220 and extend in parallel along a longitudinal (or transverse) direction of the storage unit 200. The rail system 300 may include a single rail

(not shown) such as, for example, an I-beam shaped rail (not shown). The rail system 300 may include three or more rails (not shown). The swivel base 400 may slidably engage the rail system 300. The swivel base 400 may also be connected to and support the seating unit 100, which may allow the seating unit 100 to swivel. In addition, the swivel base 400 may be height-adjustable.

[0046] The storage unit 200 and rail system 300 may be used with one or more accessories instead of or in addition to the seating unit 100. For instance, a rod holder (not shown) for holding surf-fishing rods may be coupled to the rail system 300. The rod holder (not shown) may be coupled simultaneously with the seating unit 100, or by itself.

[0047] FIG. 3 shows a cross sectional view of the rail 300A. The rail 300A may include a base plate 310, a center frame 320, a top plate 330, and/or the like. The base plate 310, center frame 320 and top plate 330 may be assembled and affixed to each other to form the rail 300A. Alternatively, the base plate 310, center frame 320 and top plate 330 may be formed as a single structure to form the rail 300A. The base plate 310, center frame 320 and top plate 330 may include materials that provide optimal strength, weight, and friction properties. For instance, the base plate 310 may include a material such as, for example, a durable lightweight polymer, or the like, that provides minimal friction along the surface while simultaneously; the center frame 320 may include a material such as, for example, steel, aluminum, or the like, that provides optimal strength and durability; and, the top plate 330 may include a material similar to that provided in the base plate 310 and/or the center frame 320, or a material that is different, as understood by those skilled in the art.

[0048] The center frame 320 may have a head portion 322 and a neck portion 324. The neck portion 324 may extend horizontally from a middle portion of a sidewall 326 of the head portion 322. The head portion 322 may have a substantially rectangular shape, as seen in FIG. 3. The head portion 322 may have any other shape, such as, for example, a circle, an ellipse, a semi-circle, or the like.

[0049] The rail 300A may be formed by, for example, placing the base plate 310 on the upper surface of the lid 220, placing the center frame 320 on the upper surface of the lid 220 and the upper surface of the base plate 310, and placing the top plate 330 on the upper surface of the center frame 320. In this regard, a surface of the head portion 322 may be placed atop of the lid 220 and a surface of the neck portion 324 may be placed on the base plate 310. The top plate 330 may be placed on the neck portion 324 such that the neck portion 324 of the center frame 320 is sandwiched between the base plate 310 and top plate 330 to form a sliding slot 305.

[0050] The base plate 310, the center frame 320 and the top plate 330 may have substantially the same length, as shown in FIGS. 1 and 2. The base plate 310 and the top plate 330 may, however, be wider than the neck portion 324 of the center frame 320. The base plate 310 and top plate 330 may be in contact with the sidewall 326 of the head portion 322. The smaller width of the neck portion 324 may create the sliding slot 305 between the base plate 310 and the top plate 330. The base plate 310, neck portion 324 and top plate 330 may include a plurality of openings that may be aligned and are configured to receive a plurality of corresponding fasteners to fasten and secure the rail 300A to the lid 220. The rail 300B may be constructed in a similar but symmetrical manner on the lid 220.

[0051] FIG. 4A shows an exploded perspective view of the storage unit 200 and the rail system 300. FIG. 4B shows an enlarged perspective view of a portion of the storage unit 200 and the rail system 300 shown in FIG. 4A, indicated by a circle A. The rail 300A may be affixed to the lid 220 using fasteners such as, for example, bolts 340, washers 342, nuts 344, and/or the like. As noted earlier, the base plate 310 may include a plurality of openings 312. The lid 220 may also include a plurality of openings 222, which may be formed to correspond to the openings 312 of the base plate 310. Similarly, the center frame 320 and the top plate 330 may also include a plurality of openings (not shown), which may be formed to correspond to the openings 222 and openings 312. The base plate 310 may be affixed to the lid 220 using fasteners such as, for example, screws 314 or the like, such that the openings 312 are aligned with the openings 222 of the lid 220. The center frame 320 and the top plate 330 may then be mounted on the base plate 310, and the bolts 340, the washers 342, the nuts 344, and/or the like, may be used to affix the entire assembly of the rail 300A to the lid 220, as shown in FIGS. 4A and 4B. The rail 300B may also be affixed to the lid 220 in a similar manner.

[0052] FIG. 5 shows a partial cross sectional view of the swivel base 400 in a slidably engaged position with respect to the rail 300A. The swivel base 400 may include a bottom panel 410, a top panel 420, and a swivel neck 430. The swivel neck 430 may include a bottom interface layer 432 and a top interface layer 434.

[0053] The bottom interface layer 432 may be affixed to the bottom panel 410, and the top interface layer 434 may be affixed to the top panel 420. The bottom panel 410 may slidably engage the rails 300A, 300B. For example, an edge portion 415 of the bottom panel 410 may be slidably placed in the sliding slot 305. The edge portion 415 may be mounted on the base plate 310 such that the swivel base 400 does not contact the lid 220. The top panel 330 may cover the edge portion 415 to prevent the swivel base 400 from departing from the rail 300A. The neck portion 324 of the center frame 320 may be slightly thicker than the edge portion 415 of the bottom panel 410, which may provide a clearance for the bottom panel 410 to slidably move along the sliding slot 305. The bottom panel 410 and the rail 300B may also be engaged in a similar manner.

[0054] The top panel 420 may be affixed to a bottom surface of the first seat portion 110 of the seating unit 100. The swivel neck 430 may allow the top panel 420 to freely swivel regardless of an orientation of the bottom panel 410. The swivel neck 430 may be configured to pivot, thereby allowing the top panel 420 to pivot with respect to the bottom panel 410. Hence, the user sitting on the assembly 10 may slidably move the seating unit 100 along the rail system 300 while rotating the seating unit 100 to face any direction.

[0055] FIG. 6A shows a bottom perspective view of the seating unit 100 and the swivel base 400. FIG. 6B shows an enlarged bottom perspective view of a portion of the seating unit 100 and the swivel base 400 shown in FIG. 6A, indicated by circle B.

[0056] Referring to FIGS. 6A and 6B concurrently, the top panel 420 of the swivel base 400 may include a plurality of openings 422, which may be formed at corners of the top panel 420. The bottom panel 410 may also have a plurality of openings 412 at corners thereof. The top panel 420 and bottom panel 410 may be configured to be interchangeable. The seating unit 100 may include a reinforcement pattern 112,

which may be formed on the first seat portion **110**, such as, for example, on a bottom surface. The reinforcement pattern **112** may include a plurality of receivers **114**, which may be located corresponding to the openings **422** of the top panel **420**, respectively. The top panel **420** of the swivel base **400** may be affixed to the bottom surface of the first seat portion **110** using fasteners such as, for example, bolts **116**, washers **118**, and/or the like. The receivers **114** may be configured receive the fasteners so as to secure the top panel **420** to the first seat portion **110**.

[0057] FIG. 7A shows a perspective view of the assembly **10**; and FIG. 7B shows an enlarged perspective view of a portion of the assembly **10** shown in FIG. 7A, indicated by circle C. Referring to FIGS. 7A, 7B concurrently, the seating unit **100** may be separated from the storage unit **200** for easier transportation and storage. As noted above with reference to FIG. 1, the seating unit **100** may be configured to fold. The seating unit **100** may be attached to the storage unit **200** by pushing the bottom panel **410** of the swivel base **400** into the sliding slots **305** (shown in FIGS. 3 and 5) of the rails **300A**, **300B**. The sliding slots **305** maybe lubricated. Alternatively or additionally, rolling bearings (not shown), such as, for example, balls, shafts, rods, or the like, may be formed in the sliding slots **305** to reduce a coefficient of kinetic (and/or static) friction between the bottom panel **410** slide and the surface of the base plate **310** (or top plate **330**). The assembly **10** may include one or more stops (not shown), which may engage ends of the rails **300A**, **300B** to prevent the swivel base **400** from escaping from the rail system **300**. The assembly **10** may include a position locking mechanism (not shown) that may be configured to lock the swivel base **400** with respect to the rail system **300**.

[0058] The locking mechanism may include, for example, a pin (not shown) that may be placed through one or more openings in the top plate **330** into the sliding slot **305** in corresponding one or more predetermined locations. The pin may be configured to engage a corresponding opening (not shown) on the portion of the swivel base **400** in the sliding slot **305**, thereby securing the swivel base **400** in one or more predetermined locations in the rail system **300**. The locking mechanism may include other known methodologies for securing an article such as a portion of the bottom plate **410** in guide channels similar to the sliding slot **305**.

[0059] FIGS. 8A and 8B show side views of the swivel base **400** in different heights. As mentioned above, the swivel base **400** may be height-adjustable. More specifically, the swivel base **400** may be constructed with conventional screw and nut mechanism (not shown), which may allow the seating unit **100** to be raised by rotating the seating unit **100** in a counter-clockwise direction and to be lowered by rotating the seating unit **100** in a clockwise direction. Alternatively, the swivel base **400** may include a hydraulic pump (not shown), which may be actuated by pushing a lever, a foot pedal or the like. FIG. 8A shows the swivel neck **430** adjusted to have a minimum height. FIG. 8B shows the swivel neck **430** adjusted to have a maximum height. As such, the swivel base **400** may allow the user to raise or lower a height of the seating unit **100** for a more comfortable seating position.

[0060] While the disclosure has been described in terms of exemplary embodiments, those skilled in the art will recognize that the disclosure can be practiced with modifications in the spirit and scope of the appended claim, drawings and attachment. The examples provided herein are merely illus-

trative and are not meant to be an exhaustive list of all possible designs, embodiments, applications or modifications of the disclosure.

What is claimed is:

1. A seat storage assembly that includes a seating unit to support a user, the seat storage assembly comprising:
  - a storage unit comprising a storage space; and
  - a rail system that mounts to the storage unit, the rail system comprising:
    - a first rail having a first sliding slot; and
    - a second rail having a second sliding slot and extending in parallel with the first rail.
2. The seat storage assembly of claim 1, wherein the storage unit comprises:
  - a main body surrounding the storage space and have an opening exposing the storage space; and
  - a lid covering the opening of the main body, wherein the rail system is affixed to an upper surface of the lid.
3. The seat storage assembly of claim 1, further comprising a base that engages the rail system and supports the seating unit, wherein the base comprises:
  - a lower panel movable along the first sliding slot and the second sliding slot;
  - an upper panel affixed to the seating unit; and
  - a neck coupled between the lower panel and the upper panel, wherein the neck allows the upper panel to rotate independently from an orientation of the lower panel.
4. The seat storage assembly of claim 1, wherein each of the first rail and the second rail comprises:
  - a bottom plate that attaches to the storage unit;
  - a center frame having a head portion and a leg portion extending laterally from a sidewall of the head portion; and
  - a top plate that attaches to the bottom plate with the leg portion of the center frame sandwiched therebetween, wherein the bottom plate and the top plate are wider than the leg portion of the center frame and in contact with the sidewall of the head portion.
5. The seat storage assembly of claim 4, wherein each of the first sliding slot and the second sliding slot is located laterally adjacent to the leg portion of the center frame and between the bottom plate and the top plate.
6. The seat storage assembly of claim 1, wherein the seating unit comprises:
  - a horizontal portion mounted on the upper panel of the base and vertically supporting a user in a seating position; and
  - a vertical portion connected to the horizontal portion and laterally supporting a back of the user in the seating position.
7. The seat storage assembly of claim 6, wherein the seating unit further comprises a reinforcement pattern formed on a bottom surface of the horizontal portion, and wherein the upper panel of the base attaches to the reinforcement pattern.
8. The seat storage assembly of claim 6, wherein the seating unit is foldable.
9. The seat storage assembly of claim 8, wherein the seating unit comprises a pivot joint coupled between the horizontal portion and the vertical portion.
10. The seat storage assembly of claim 1, wherein the base is height-adjustable.

- 11.** A seat storage assembly comprising:  
a storage unit comprising a storage space for holding an item;  
a rail system that attaches to the storage unit; and  
a seating unit that attaches to the rail system.
- 12.** The seat storage assembly of claim **11**, further comprising a base that attaches to the rail system, wherein the base comprises:  
a lower panel coupled to the rail system;  
an upper panel coupled to the seating unit; and  
a neck coupled between the lower panel and the upper panel,  
wherein the neck allows the upper panel to move independently from an orientation of the lower panel.
- 13.** The seat storage assembly of claim **11**, wherein the rail system comprises:  
a first rail having a first sliding slot; and  
a second rail having a second sliding slot and extending in parallel with the first rail.
- 14.** The seat storage assembly of claim **11**, wherein the seating unit is foldable.
- 15.** The seat storage assembly of claim **12**, wherein the base is height-adjustable.
- 16.** A seat storage assembly, comprising:  
a storage unit that has a storage space and a lid;  
a rail system that attaches to the lid of the storage unit, the rail system including a rail having a sliding slot; and  
a base that engages the rail system.
- 17.** The seat storage assembly of claim **16**, wherein the rail attaches to the lid along a longitudinal direction of the storage unit.
- 18.** The seat storage assembly of claim **16**, further comprising a seating unit that attaches to the base, wherein the seating unit comprises:  
a first portion that supports the user in a first direction in the seating position, and  
a second portion that supports a back of the user in a second direction in the seating position.
- 19.** The seat storage assembly of claim **16**, wherein the base is height-adjustable.
- 20.** The seat storage assembly of claim **16**, wherein the rail system comprises another rail that engages the base.

\* \* \* \* \*