

June 29, 1937.

M. SALGO
DISPLAY STAND

2,085,335

Filed May 20, 1936

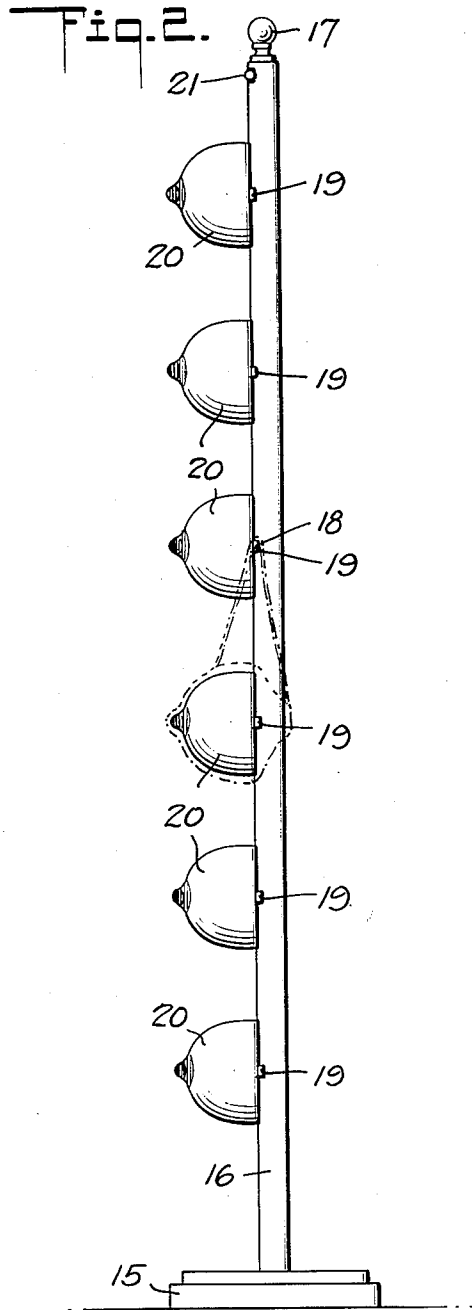
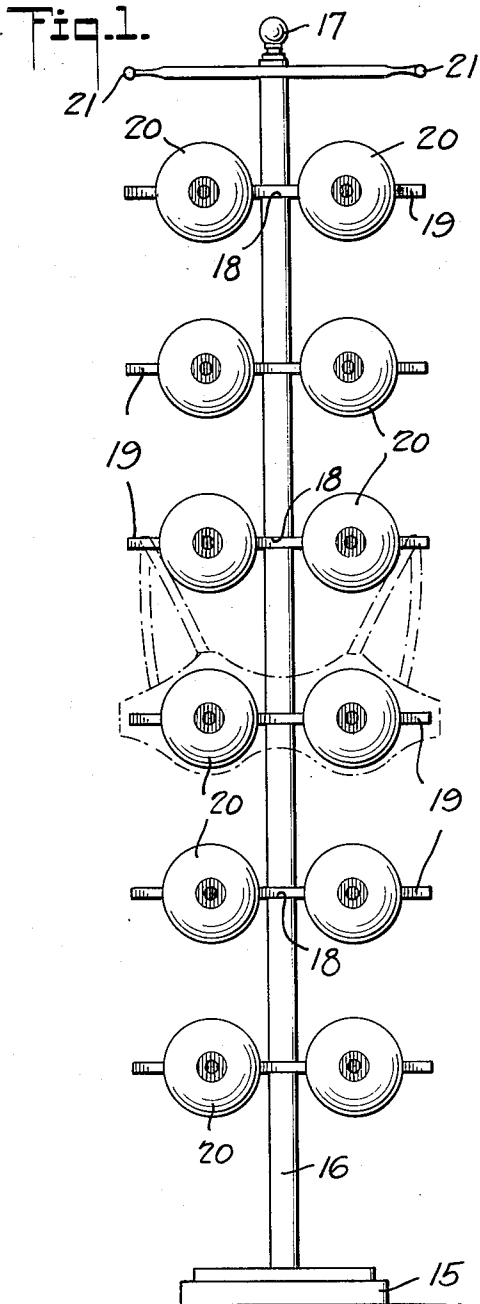

INVENTOR
MARTIN SALGO
BY

Edwin D. Jones,
ATTORNEY

UNITED STATES PATENT OFFICE

2,085,335

DISPLAY STAND

Martin Salgo, Beverly Hills, Calif.

Application May 20, 1936, Serial No. 80,750

1 Claim. (Cl. 223-66)

My invention relates to display stands, and it has for a purpose the provision of a display stand structurally characterized by its simplicity and low cost of manufacture, and functionally characterized by its ability to support a plurality of brassières in such extended form as they would appear when worn on the body whereby, the display effectiveness of the brassières is greatly enhanced.

It is also a purpose of my invention to provide a display stand for brassières which embodies one or more pairs of bust forms on which the pockets of a brassière are supported in a naturally extended position, while the shoulder straps are extended over a support to aid in maintaining the brassière pockets on the bust forms at the same time displaying the shoulder straps.

I will describe only one form of display stand for brassières embodying my invention and will then point out the novel features thereof in the claim.

In the accompanying drawing:

Fig. 1 is a view showing in front elevation one form of display stand embodying my invention.

Fig. 2 is a view showing the display stand in side elevation.

In carrying out my invention I provide a display stand which comprises a base 15 preferably of square form, to the center of which is secured an upright or standard 16 preferably square in cross section, which rises to any height desired. Screwed or otherwise secured to the upper end of the standard is an ornamented knob 17.

The front side of the standard is formed at regularly spaced intervals along its length with transverse grooves 18 in each of which is secured by nailing or glueing a cross arm 19. The arm 19 extends to opposite sides of the standard for equal distances, and it is preferably of square form in cross section.

Suitably secured to the front side of each cross arm, with the exception of the uppermost arm, and at opposite sides of the standard 16 are a pair of forms 20, each made preferably of wood and having the form of a bust with the body painted flesh color and the nipple painted to simulate a natural nipple. The uppermost arm terminates at its ends in ornaments 21 of any suitable design.

In practice, a brassière may be advantageously displayed by applying it to any one pair of bust forms 20 so that the respective pockets of the brassière are received by the forms in the manner illustrated in dash lines in Fig. 1. The ends

of the brassière are next extended around the ends of the respective cross arm and secured together by the usual fastener thereon. This operation is followed by looping the two shoulder straps of the brassière over the respective ends of the next cross arm above in the manner illustrated in Fig. 1. In this manner the shoulder straps function to confine the bust pockets on the forms and sustain the body of the brassière horizontally on the cross arm. It will be understood that the uppermost cross arm forms a support for the shoulder straps of a brassière applied to the forms on the cross arm next beneath.

With a brassière applied as described it will be manifest that the shoulder straps and the body of the brassière are supported in extended position on the stand to effectively display the brassière, and with the bust pockets fitted over the forms, and the forms shaped and colored to simulate the natural bust the realistic manner of display of the whole brassière becomes striking.

Manifestly any adjacent pair of cross arms and the bust forms of the lower arm of the pair coact to form a brassière supporting unit, and by arranging these units one above the other on a single upright support, a plurality of brassières can be effectively displayed on a counter where space is usually at a premium.

Although I have herein shown and described only one form of display stand embodying my invention, it is to be understood that various changes and modifications may be made herein without departing from the spirit of my invention and the spirit and scope of the appended claim.

I claim:

A display stand for brassières, comprising; an upright; a cross arm secured to the upright; a pair of bust forms secured in side by side relation on the cross arm and over which the pockets of a brassière are adapted to be fitted, the bust forms being spaced from the ends of the cross arms so that parts of the brassière can be supported in extended position laterally from the bust pockets when the brassière is extended around the cross arm and its ends fastened at the back of the upright; and a second cross arm secured to the upright above the first mentioned cross arm, the second mentioned cross arm disposed to the rear of the bust forms and a distance thereabove so that when the shoulder straps of the brassière are extended over said cross arm the shoulder straps will serve to maintain the pockets on said forms.

MARTIN SALGO.