



(22) **Date de dépôt/Filing Date:** 2014/07/11

(41) **Mise à la disp. pub./Open to Public Insp.:** 2015/01/25

(30) **Priorité/Priority:** 2013/07/25 (US13/950522)

(51) **Cl.Int./Int.Cl.** E05F 1/10 (2006.01)

(71) **Demandeur/Applicant:**  
CMECH (GUANGZHOU), LTD., CN

(72) **Inventeur/Inventor:**  
CHAO, WEI JIN, CN

(74) **Agent:** PERRY + CURRIER

(54) **Titre : ENSEMBLE DE FERMETURE DE PORTE A SUPPORT**

(54) **Title: BRACKET DOOR CLOSURE ASSEMBLY**

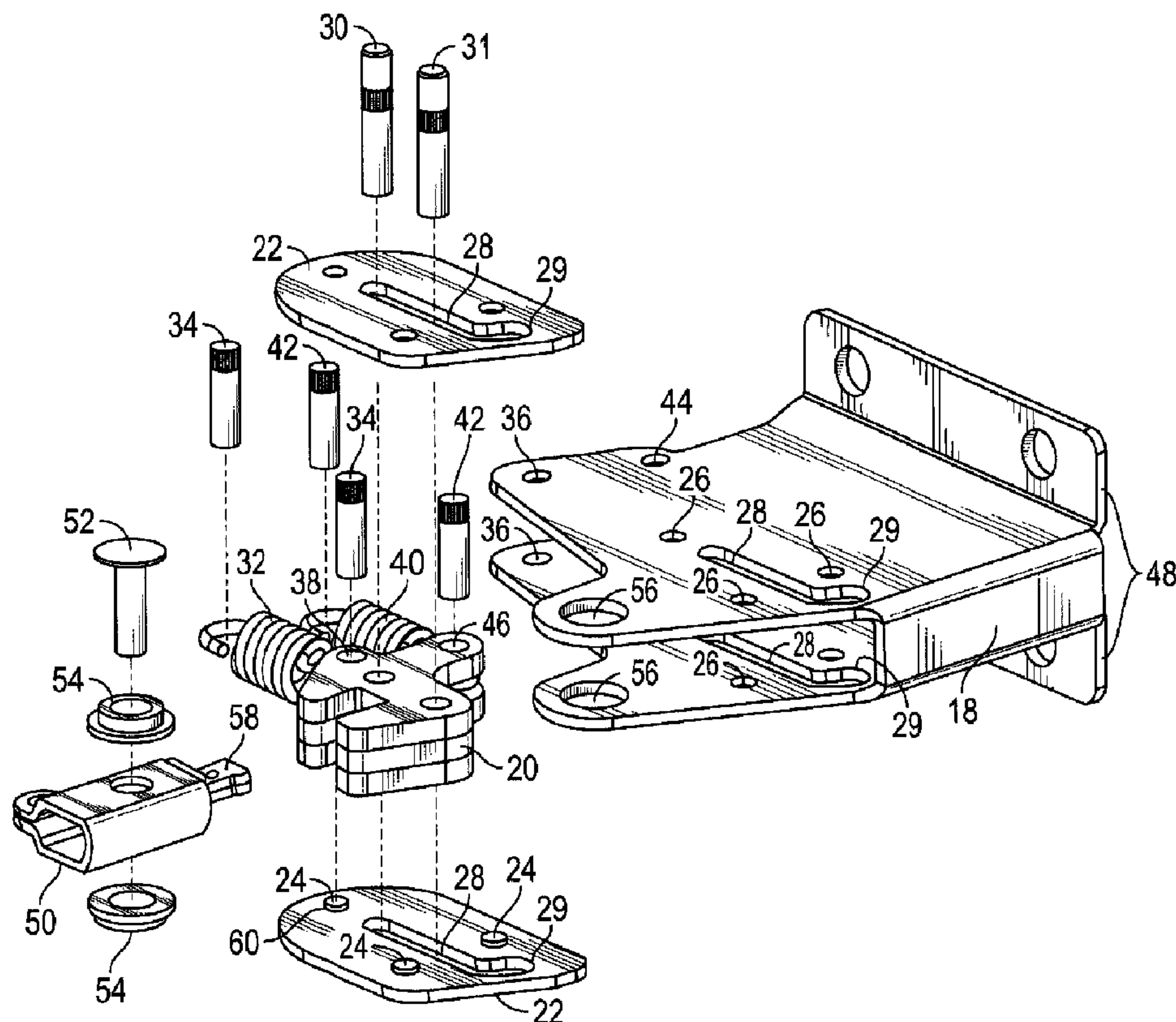

(57) **Abrégé/Abstract:**

A door closure assembly is provided to automatically pull a storm or screen door to a fully closed position without user action. The door closure assembly includes a bracket housing with a cam switch movable along a track as the door opens and closes. The closure cylinder rod is engaged with the cam switch until the door is fully opened. The cam switch biases the closure cylinder and rod as the door approaches the closed position.

**ABSTRACT**

A door closure assembly is provided to automatically pull a storm or screen door to a fully closed position without user action. The door closure assembly includes a bracket housing with a cam switch movable along a track as the door opens and closes. The  
5 closure cylinder rod is engaged with the cam switch until the door is fully opened. The cam switch biases the closure cylinder and rod as the door approaches the closed position.

## BRACKET DOOR CLOSURE ASSEMBLY

This application claims the benefit of US Patent Application No. 13/950522 filed July 25, 2013, the entire contents of which are incorporated herein by reference.

### 5 FIELD OF THE INVENTION

A door closure assembly is provided for a screen or storm door to automatically fully close the door without user interaction.

### BACKGROUND OF THE INVENTION

10 Storm doors and screen doors have a long-term problem of failure to completely close on their own. Complaints from users and manufacturers indicate that these storm and screen doors do not always automatically close and fully seal shut when relying solely on the closing strength of the standard pneumatic or hydraulic door closure. This problem arises, at least in part, due to the air pocket or space between the primary door and storm  
15 door which prevents the outer storm/screen door from fully closing shut. Past attempts to resolve this problem include an air release mechanism which functions as the door closes to release air from the space as the space narrows, though results are inconsistent with this air release system. Also, consumers are hesitant to pay for add-on parts which attempt to fix the problem.

20 Accordingly, a primary objective of the present invention is the provision of an improved door closure which assures that a storm or screen door will be fully shut and sealed automatically solely by the action of the improved door closure.

Another objective of the present invention is the provision of a door closure which mechanically urges a storm or screen door to a fully closed and sealed position.

25 Another objective of the present invention is the provision of a storm and screen door closure which is spring biased to a fully closed position.

Yet another objective of the present invention is the provision of a storm and screen door closure having cam action to facilitate complete closure of the door.

30 Still another objective of the present invention is a provision of a storm and screen door closure which utilizes a pneumatic or hydraulic cylinder in combination with a pivotal cam to facilitate full closure of the door.

Another objective of the present invention is the provision of an improved storm and screen door closure which assures complete closure of the door without user effort.

A further objective of the present invention is the provision of an improved storm and screen door closure which is economical to manufacture, and durable and safe in use.

5        These and other objectives will become apparent from the following description of the invention.

### **SUMMARY OF THE INVENTION**

10        The storm and screen door closure of the present invention includes a bracket fixed on the door jamb and a pneumatic or hydraulic cylinder fixed to the storm or screen door. The bracket includes a cam switch which is slidably and pivotally mounted in the bracket. The hydraulic cylinder includes a rod having an outer end slidably received in a slot in the cam switch so as to be engaged in the cam switch when the door is closed and disengaged from the cam switch when the door is fully opened. The cam switch is spring biased so as  
15        to urge the cylinder rod to a retracted position and thereby fully close the door.

As the storm or screen door is opened, the outer end of the cylinder rod slides and pivots the cam switch until the rod is disengaged from the cam switch. As the door begins to close, the end of the rod re-engages with the cam switch. A spring connected to the cam switch pulls the cam switch so as to retract the rod and fully close the storm or screen door.

20

### **BRIEF DESCRIPTION OF THE DRAWINGS**

Figure 1 is a perspective view of the bracket door closure assembly of the present invention.

25        Figure 2 is an exploded view of the bracket door closure assembly of the present invention.

Figure 3A is a top plan view of the bracket door closure assembly mounted to a door jamb or frame and a screen or storm door, with the bracket door being in a fully closed position.

30        Figure 3B is an enlarged plan view of the bracket door closure assembly and cylinder rod when the door is fully closed.

Figure 3C is a view similar to Figure 3B showing the position and relationship between the cam switch and the closure rod when the door is fully closed.

Figures 4A-4C are similar to Figures 3A-3C, but showing the door in an initial opening position, and with the broken lines showing continued opening of the door.

Figures 5A-5C are similar to Figures 4A-4C, but with the door opened further.

Figures 6A-6C are similar to Figures 5A-5C, except with the door in a fully opened  
5 position.

Figures 7A-7C are similar to Figures 6A-6C, except with the door in an initial closing position from the fully opened position, and with the broken lines showing continued closing of the door.

Figures 8A-8C are similar to Figures 7A-7C, except with the door in a further  
10 closed position, and broken lines showing the door in a fully closed position.

Figure 9 is a perspective view of an alternative embodiment of the bracket door closure assembly of the present invention.

Figure 10 is an exploded perspective view of the bracket door closure assembly shown in Figure 9.

Figure 11 is a partially exploded view of the cam switch, rod insert, and spring  
15 components of the embodiment shown in Figure 9.

#### **DETAILED DESCRIPTION OF THE PREFERRED EMBODIMENTS**

The door closure assembly 10 of the present invention includes a bracket assembly  
20 12 and a pneumatic or hydraulic cylinder 14 with an extensible and retractable rod 16 extending between the bracket assembly 12 and the cylinder 14. The cylinder 14 and rod 16 create a linear actuator for facilitating closure of the door.

The bracket assembly 12 includes a housing 18 with a pivotal and slidable cam  
25 switch 20. More particularly, a pair of track plates 22 is mounted on opposite sides of the housing 18 in any convenient manner. For example, as shown in Figure 2, the track plate 22 include stubs 24 which are press fit into holes 26 on the bracket housing 18. The track plates 22 and the opposite sides of the housing 18 include an elongated slot 28 with an angled head 29. The cam switch 20 resides between the opposite sides of the housing 18 and is slidable along the slots 28 via mounting pins 30, 31. The cam switch 20 is biased to  
30 the outer ends of the slots 28 opposite the head 29 by a spring 32. The spring 32 is mounted at opposite ends to the bracket housing 18 and to the cam switch 20 by pins 34

which extend through holes 36 in the bracket housing 18 and through a hole 38 in the cam switch 20.

A second spring 40 is offset from the first spring 32. The spring 32 is connected to the bracket housing 18 and to the switch plate 20 by pins 42 extending through holes 44 in  
5 the bracket housing 18 and a hole 46 in the switch plate 20. As discussed in more detail below, when the screen or storm door is fully opened, the spring 42 retains the switch plate at the inner end of the slot head 29.

The bracket assembly 12 also includes a rod insert 50. The insert 50 has an open  
10 end to receive the outer end of the cylinder rod 16 which is retained in the insert 50 by a pin 52. The pin 52 also extends through bushings 54 mounted in holes 56 in the bracket housing 18, such that the rod insert 50 is pivotally mounted to the housing 18. The rod insert 50 also has a free end 58 which is slidably received in a recess or notch 60 in the cam switch 20. The insert 50 forms an extension on the end of the rod 16.

The bracket housing 18 includes opposite flanges 48 for mounting the housing 18  
15 to a door frame or jamb 62. The cylinder 14 is pivotally mounted to the storm or screen door 64 in a conventional manner.

Figures 3-8 show a series of movements for the door 64 and door closure assembly  
20 10. In Figures 3A-3C, the door 64 is fully closed. The cylinder 14 and rod 16 extend at an angle of approximately 5 degrees from the plane of the door, when the door is closed. In the door closed position, the end 58 of the rod insert 50 is received in the notch 60 of the cam switch 20, as shown in Figure 3C. The cam switch 20 is in a closed position and is biased to the outer end of the slot 28 by the spring 32.

As the door 64 begins to open, as shown in Figures 4A-4C, the rod 16 begins to  
25 retract from the cylinder 14 and the cam switch 20 moves inwardly along the slot 28 of the bracket housing 18 and track plates 22, as seen in Figures 4B and 4C.

As the opening movement of the door 64 continues (Figures 5A-5C), the end 58 of  
the insert 50 moves out of the notch 60 of the cam switch 20, and the cam switch 20 continues to move inwardly in the slots 28. The second spring 40 pivots the cam switch 20 so that the second pin 31 moves into the head 29 of the slots 28.

30 Figures 6A-6C show the door 64 in a fully open position, with the end 58 of the insert 50 completely disengaged from the cam switch 20 (Figure 6C). The second spring 40 and the upper pin 31 in the head 29 of the slot 28 prevent the cam switch 20 from being

pulled outwardly by the first spring 32 along the slot 28. The cam switch 20 is pivoted inwardly to an open position by the spring 40.

As the door 64 begins to close, as shown in Figures 7A-7C, the end 58 of the insert 50 is re-introduced into the notch 60 of the cam switch 20, thereby pivoting the cam switch 20 so that the spring 30 will pull the pins 30, 31 outwardly along the slot 28. As the door is nearing full closure, as shown in solid lines in Figures 8A-8C, the spring 32 pivots the cam switch 20 against the end 58 of the rod insert 50, thereby urging the door to a fully closed position, shown in broken lines in Figures 8A-8C. Thus, the outward linear movement of the cam plate 20 along the slots 28 via the spring 32 provides a pivotal force on the rod insert 50, rod 16 and cylinder 14 to automatically pull the door to the fully closed and sealed position, without user interaction.

An alternative embodiment of the bracket door closure assembly 12A is shown in Figures 9-11. The primary difference between the alternative embodiment 12A and the embodiment 12 shown in Figures 1-8 is the use of a torsion spring 70 in the alternative embodiment, rather than the compression springs 32, 40 in the first embodiment 12. Similar components are labeled with the same reference numerals in the alternative embodiment as in the first embodiment.

More particularly, the torsion spring 70 includes opposite ends 72, 74. The first end 72 is retained by a pin 76 extending through holes 78 in the bracket housing 18. A bushing 80 extends through the housing 18 and the center of the spring 70. The second end 74 of the spring 70 rests upon a lip or shelf 82 of the cam switch 20. As seen in Figure 10, the cam switch 20 may be comprised of plates 20A, 20B, and 20C, with the center plate 20B being sandwiched between the outer plates 20A and 20C. The shelf 82 is formed on the center plate 20B. Alternatively, the cam switch can be formed as a one piece integral member.

The function of the alternative embodiment closure assembly 12A is the same as the primary embodiment closure assembly 12.

The invention has been shown and described above with the preferred embodiments, and it is understood that many modifications, substitutions, and additions may be made which are within the intended spirit and scope of the invention. From the foregoing, it can be seen that the present invention accomplishes at least all of its stated objectives.

**CLAIMS**

1. A door closure assembly for a storm or screen door movable between opened and closed positions relative to a door frame, comprising:  
a bracket attachable to the door frame;  
5 a cylinder and rod assembly having a first end extending into the bracket and a second end adapted to be attached to the storm door; and  
the bracket including a spring to apply a force to the storm door to pull the storm door to a closed position.
- 10 2. The door closure assembly of claim 1 wherein the bracket further comprises a cam switch pivotally movable between a closed position for when the storm door is to be closed and an open position for when the storm door is to be opened.
3. The door closure assembly of claim 2 wherein the cam switch includes a slot to  
15 slidably receive the first end of the cylinder and rod assembly.
4. The door closure assembly of claim 3 wherein the bracket includes a pivotal member to which the first end of the cylinder and rod assembly is connected, the member being engaged with the cam switch when the door is to be opened and closed, and the  
20 member being disengaged with the cam switch when the door is to be fully opened.
5. The door closure assembly of claim 2 wherein the bracket further comprises a pair of plates sandwiching the cam switch therebetween.
- 25 6. The door closure assembly of claim 5 wherein the plates have aligned slots and a pin extends through the slots and the cam switch to provide pivotal movement of the cam switch about the pin.
7. The door closure assembly of claim 2 wherein the cam switch pivots about a  
30 substantially vertical axis when the door closure assembly is mounted to the door frame.

8. The door closure assembly of claim 2 wherein the spring is attached to the cam switch and biases the cam switch to the closed position for use in closing the door.
9. The door closure assembly of claim 8 further comprising a second spring attached  
5 to the cam switch and biases the cam switch to the open position for use in opening the door.
10. The door closure assembly of claim 1 wherein the spring is a torsion spring.
- 10 11. A door closure assembly for a storm or screen door hinged to a door jamb, the assembly comprising:  
a bracket fixable to the door jamb;  
a cylinder fixable to the storm door;  
a rod having opposite first and second ends extending between the cylinder and the bracket  
15 and being extensible and retractable relative to the cylinder for use in opening and closing the door;  
a cam on the bracket and operatively connected to the rod to urge the rod to a retracted position for use in pulling the door closed.
- 20 12. The door closure assembly of claim 11 further comprising a rod extension having a first end to receive the rod and a second end releasably received in the cam.
13. The door closure assembly of claim 11 wherein the cam is slidably and pivotally mounted in the bracket and moveable into engagement with the second end of the rod  
25 extension for when the door is closed, and moveable out of engagement with the rod extension for when the door is fully open.
14. The door closure assembly of claim 11 wherein the cam is biased to a first position by a first spring when the storm door is closing and is biased to a second position by a  
30 second spring when the storm door is opening.

15. The door closure assembly of claim 14 wherein the first and second springs extend between the bracket and the cam.
16. The door closure assembly of claim 14 wherein the first spring pivots the rod about  
5 a vertical axis so as to facilitate full closure of the door, when the door closure assembly is mounted to the door frame.
17. The door closure assembly of claim 11 further comprising a torsion spring to bias the cam to a closed position.
- 10
18. A method of closing a storm or screen door hinged to a door frame, comprising:  
retracting a linear actuator having a first end connected to the door and a second end  
connected to a bracket mounted on the door frame so as to move the door from an  
open position to a substantially closed position;  
15 applying a force from the bracket to the actuator to pull the door to a fully closed position.
19. The method of claim 18 further comprising pivoting the actuator about a vertical axis via the force.
- 20
20. The method of claim 18 wherein the force is created by a spring extending between the bracket and the actuator.
21. The method of claim 18 wherein the force is applied by a cam on the bracket which engages the linear actuator during closing of the door.
- 25
22. The method of claim 21 further comprising moving the cam between open and closed positions as the door opens and closes, respectively.

1/17

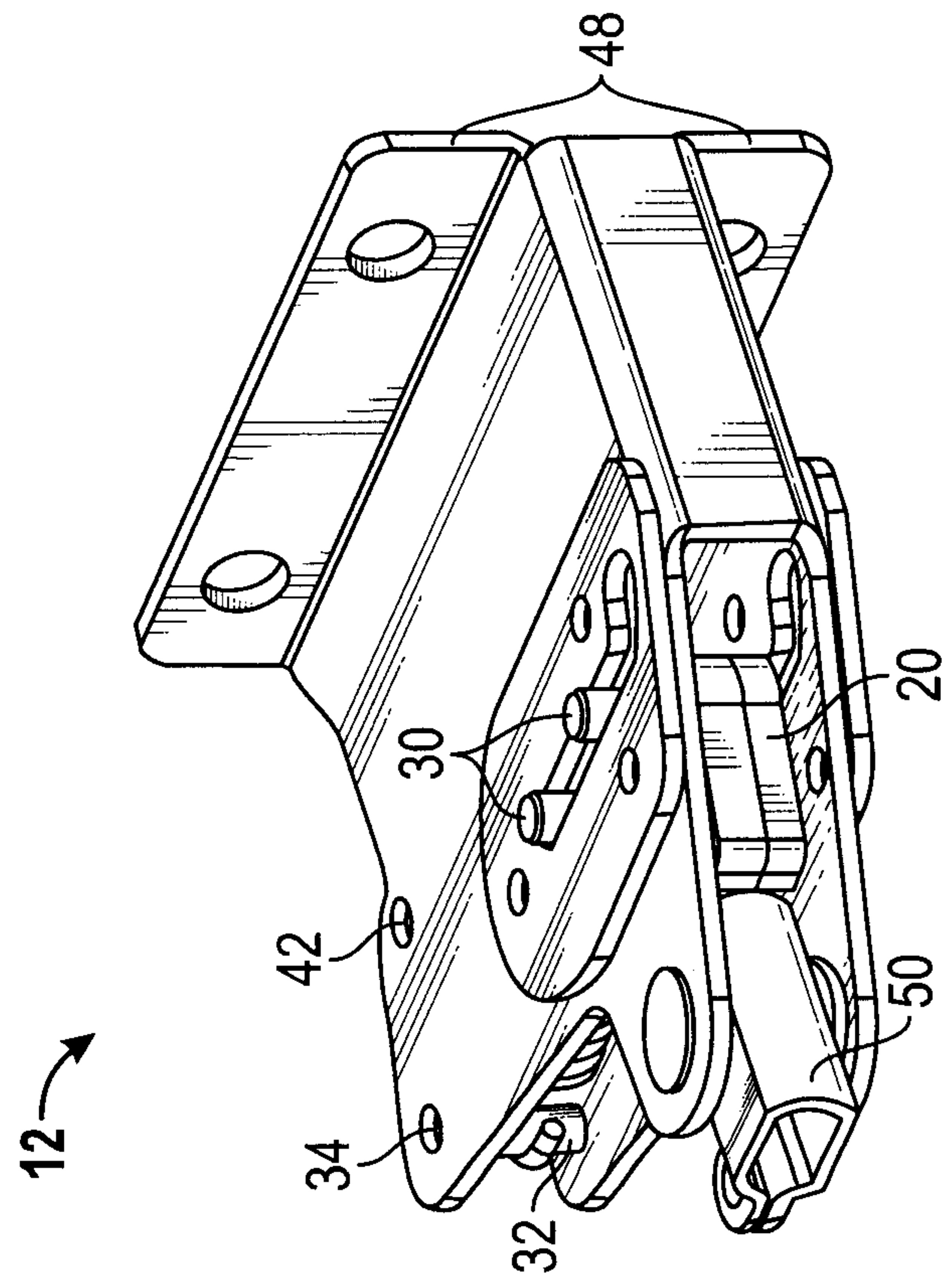

FIG. 1

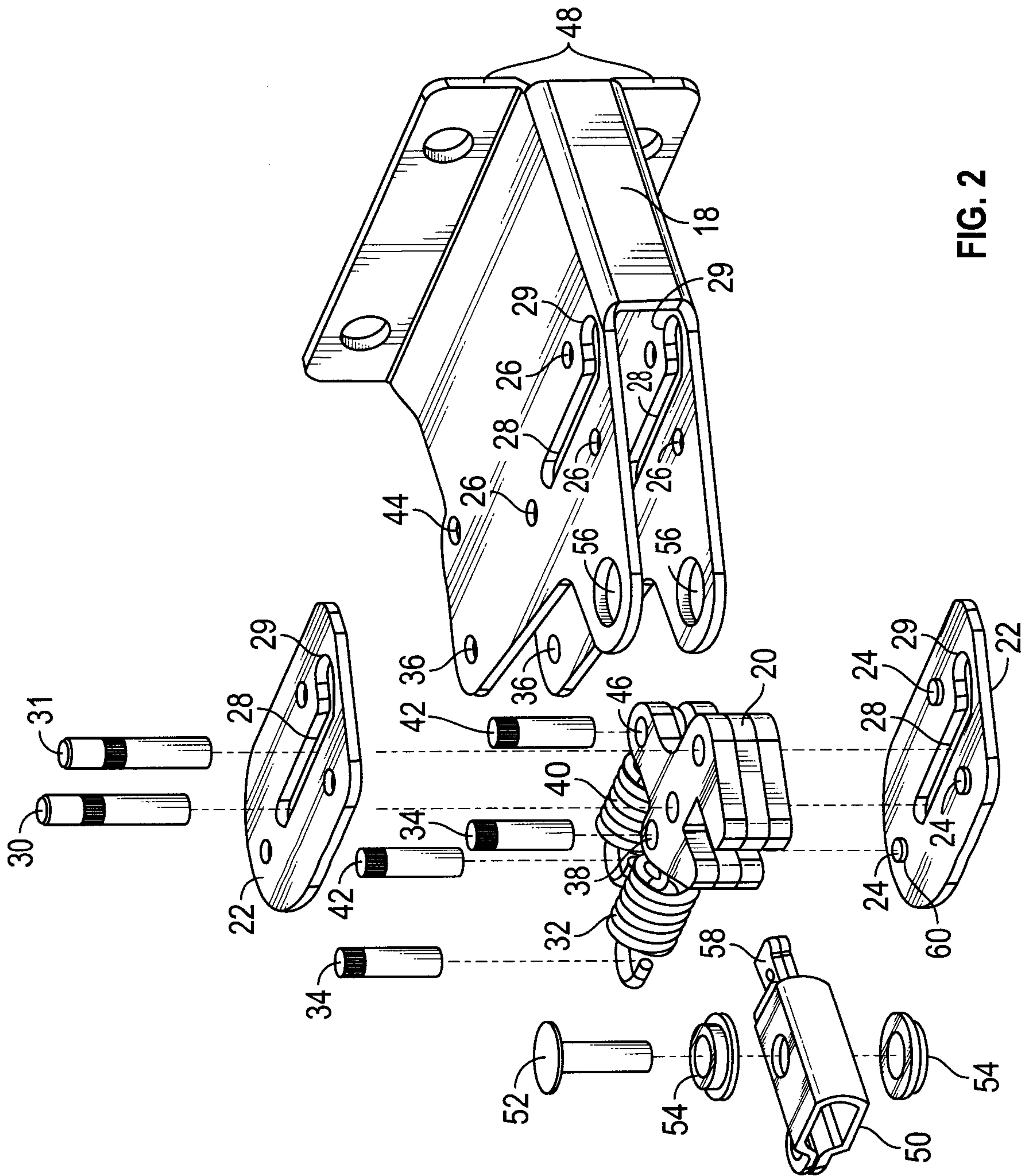

FIG. 2

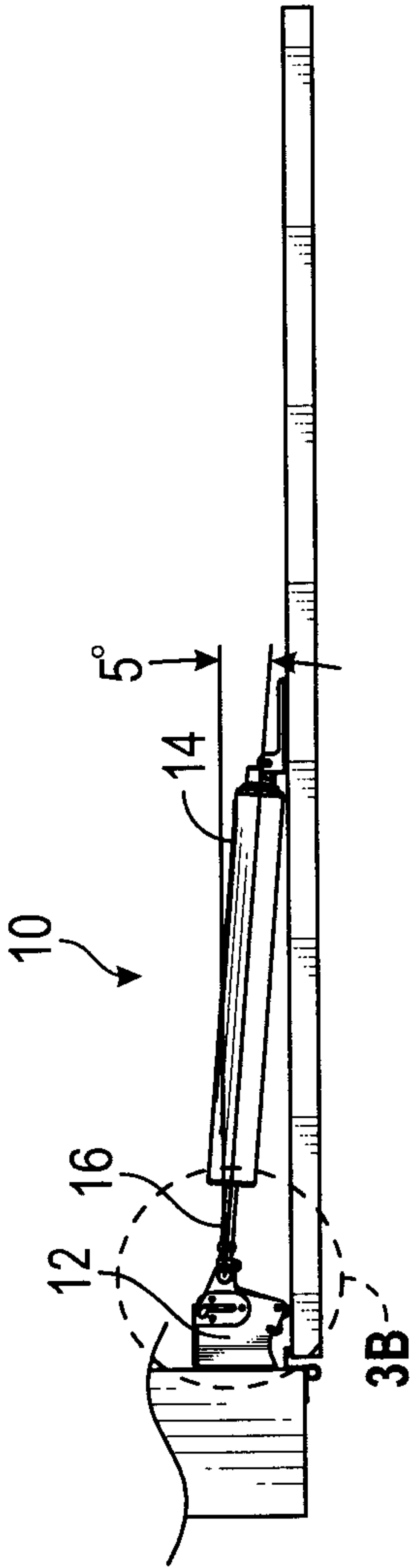

FIG. 3A

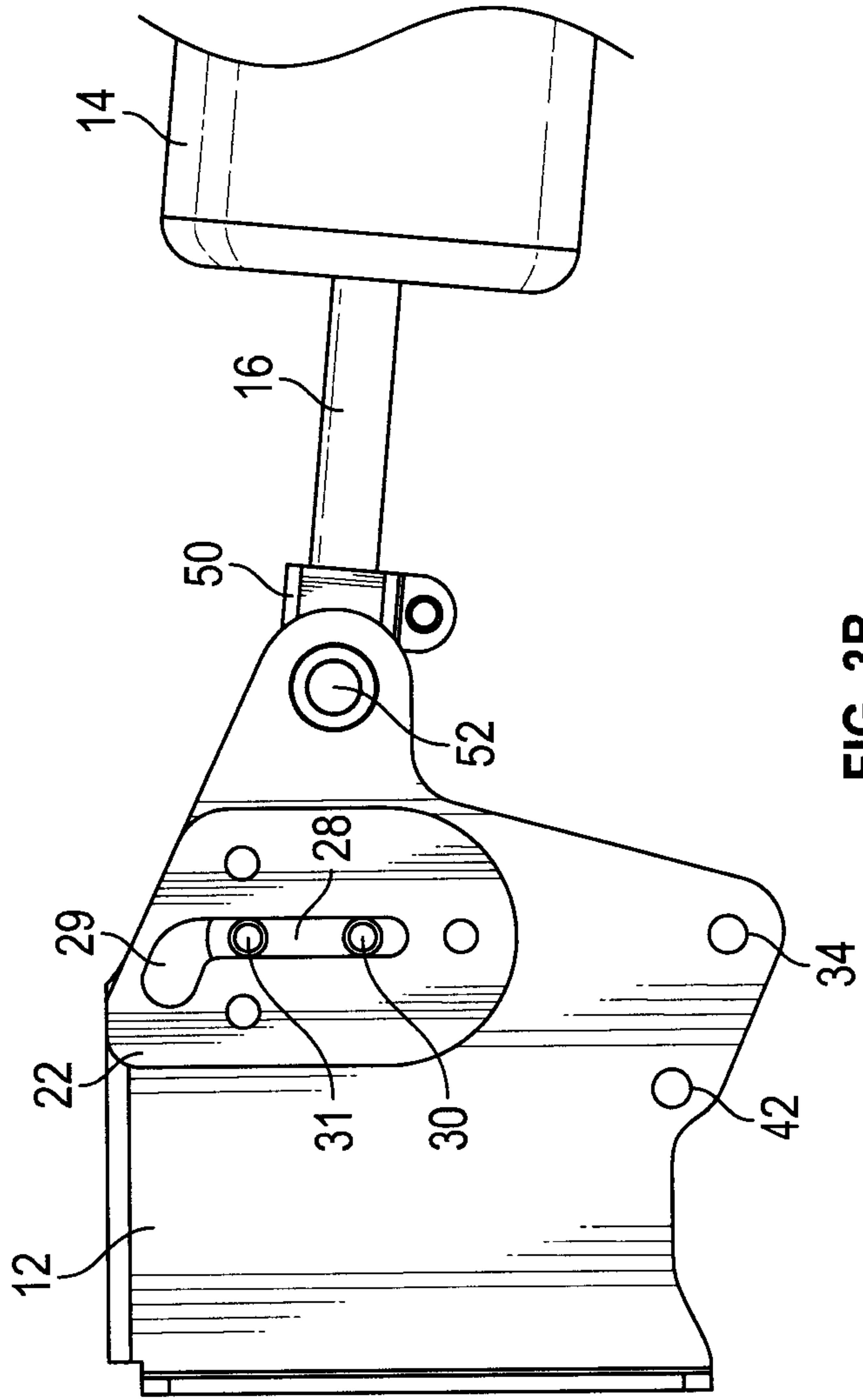

FIG. 3B

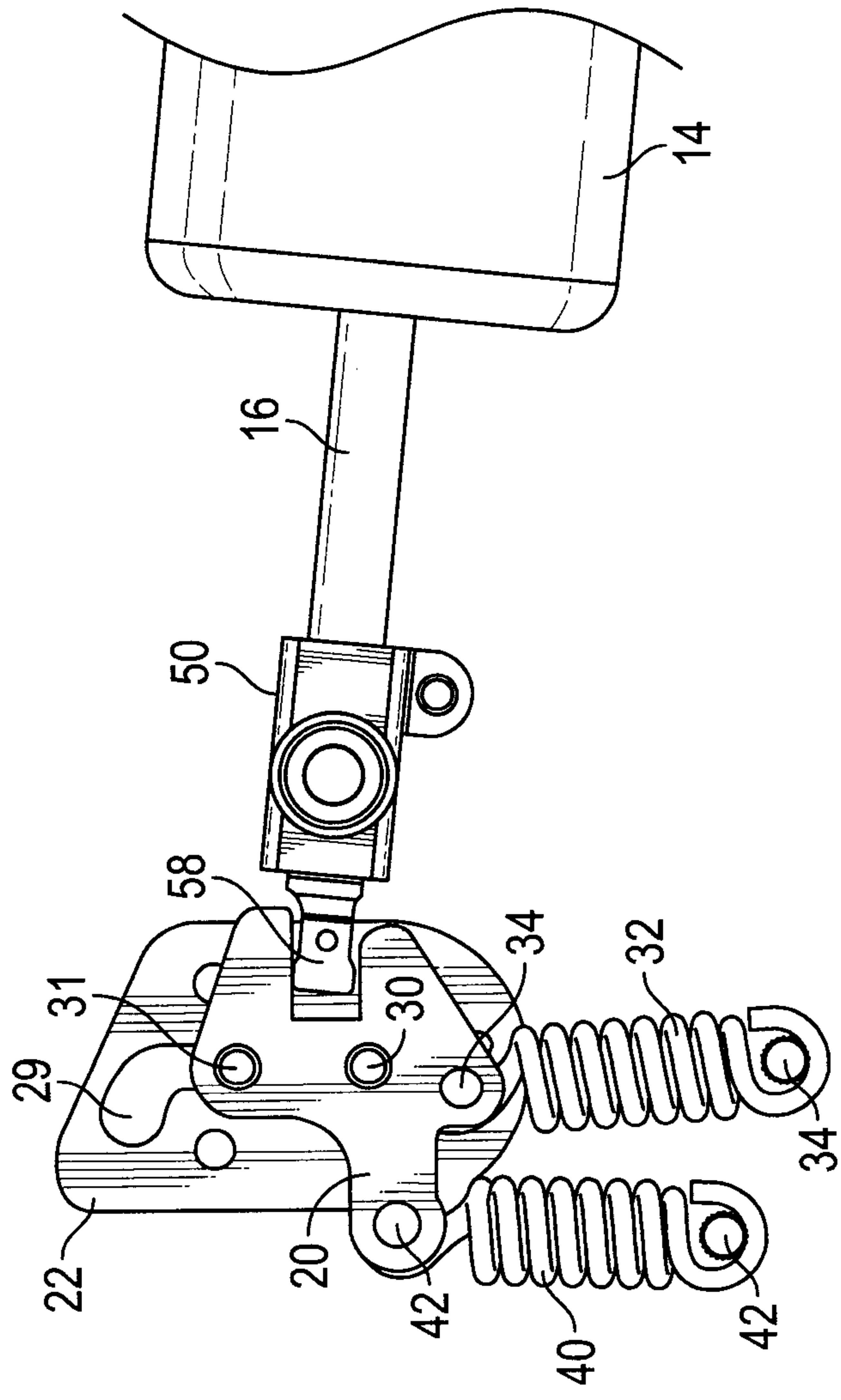

FIG. 3C

5/17

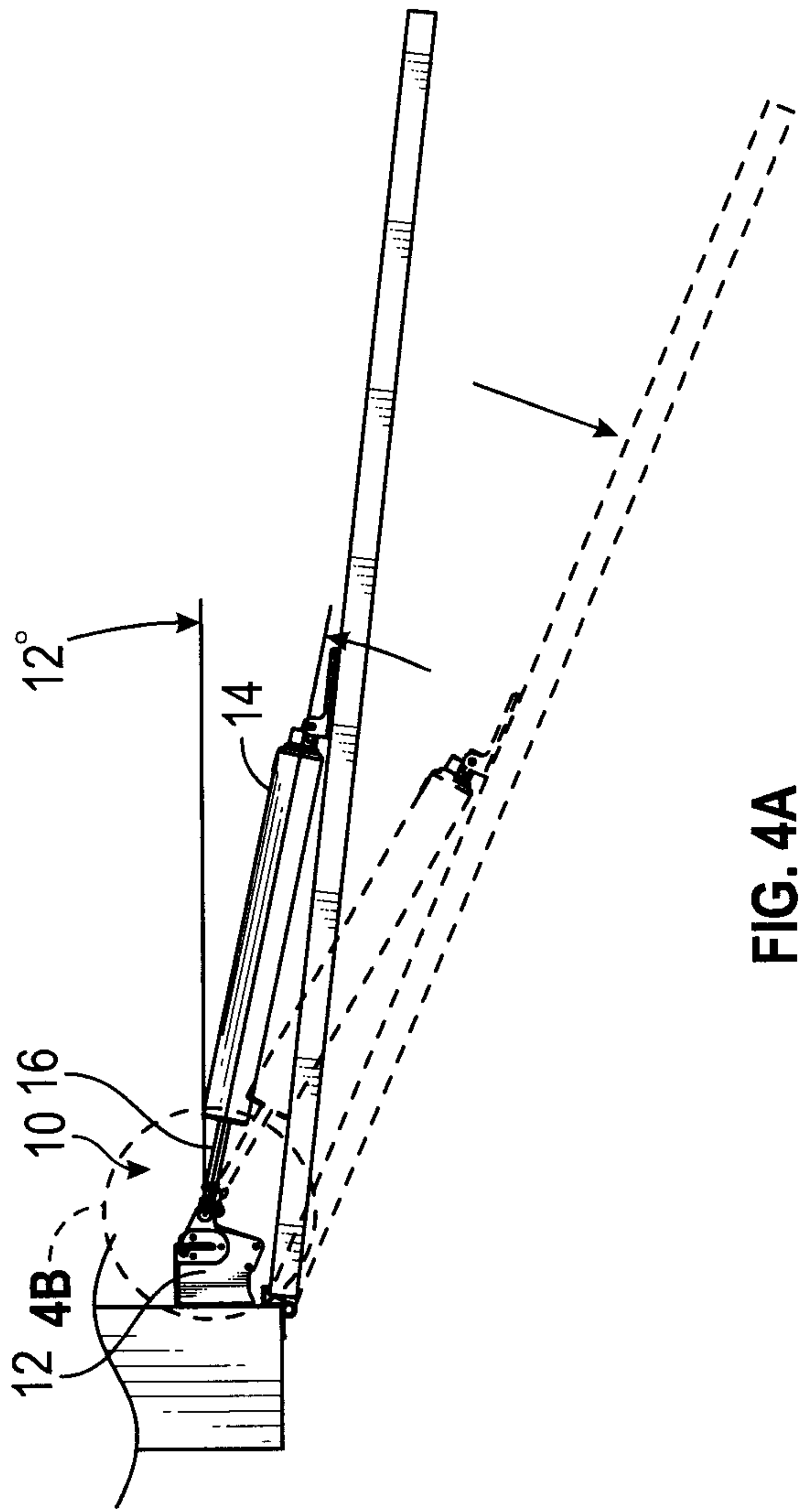

FIG. 4A

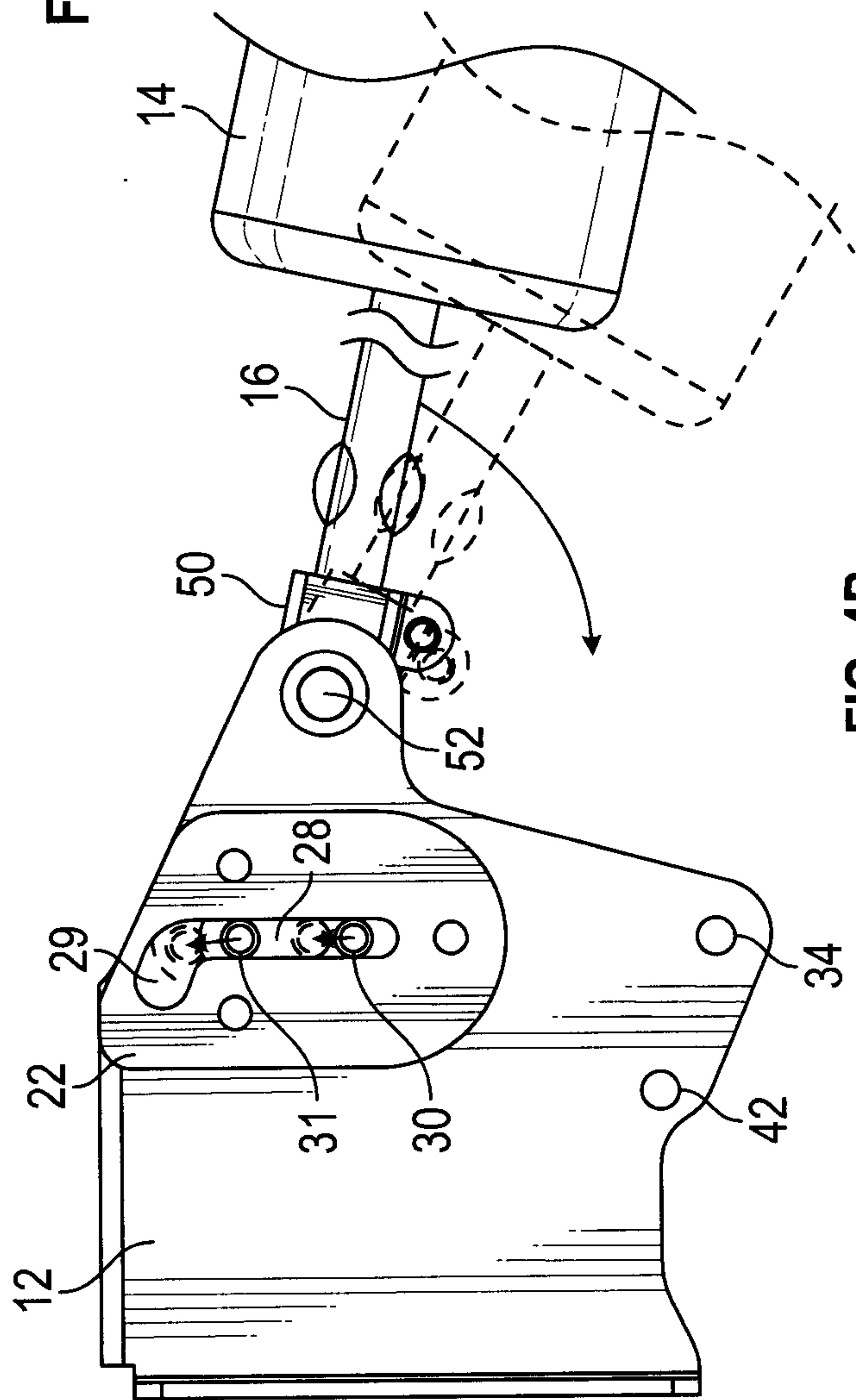

FIG. 4B

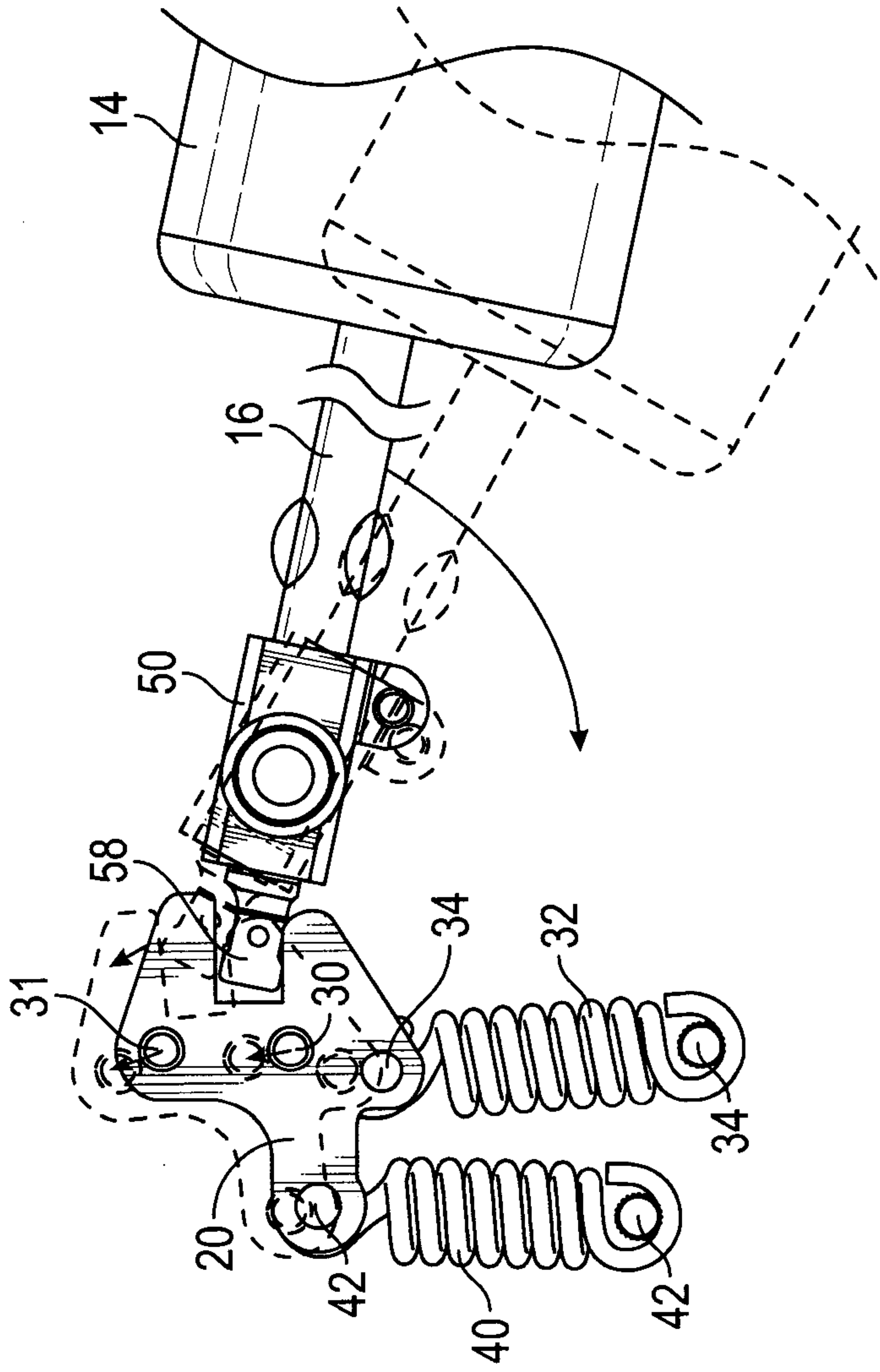
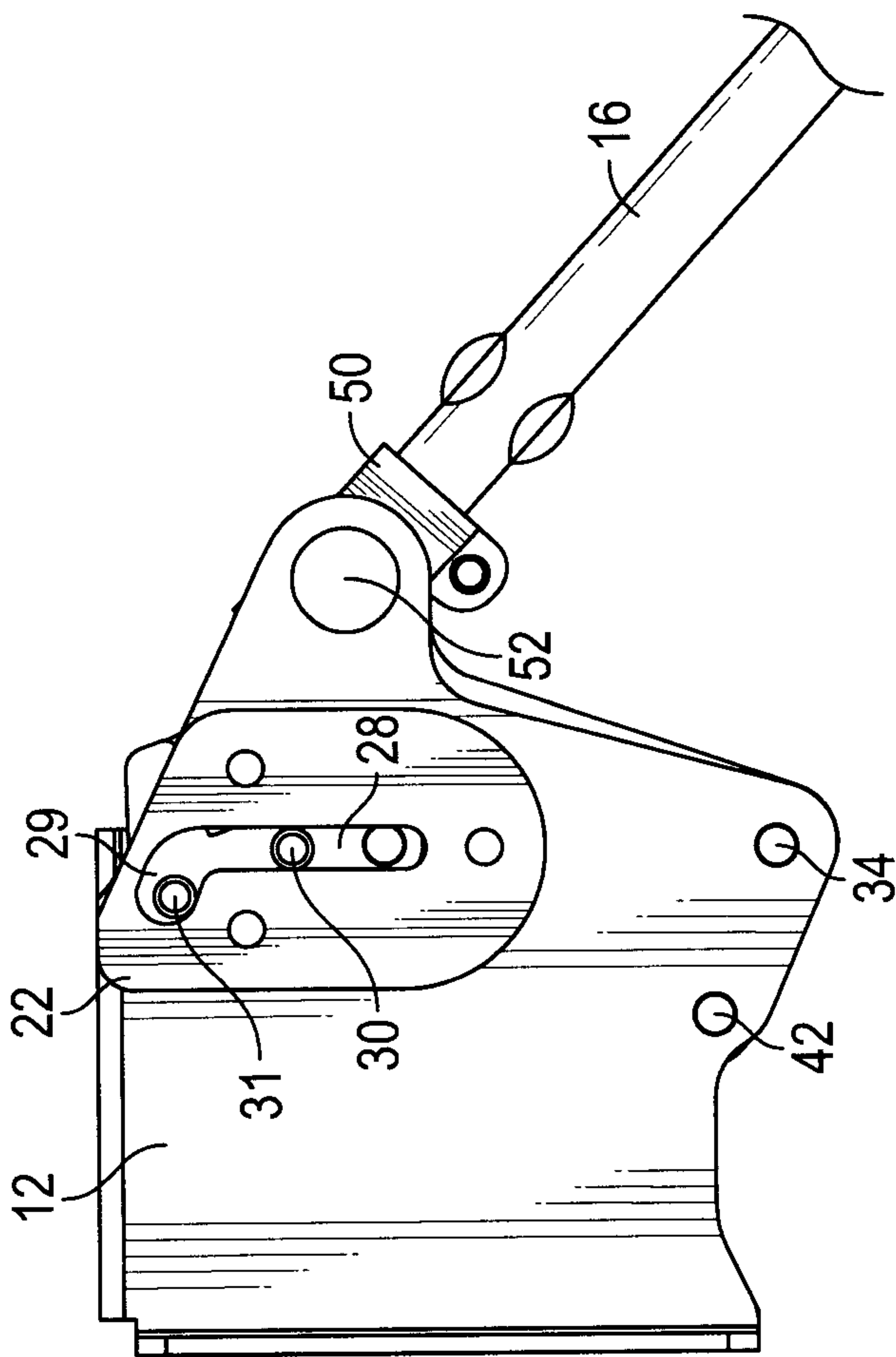
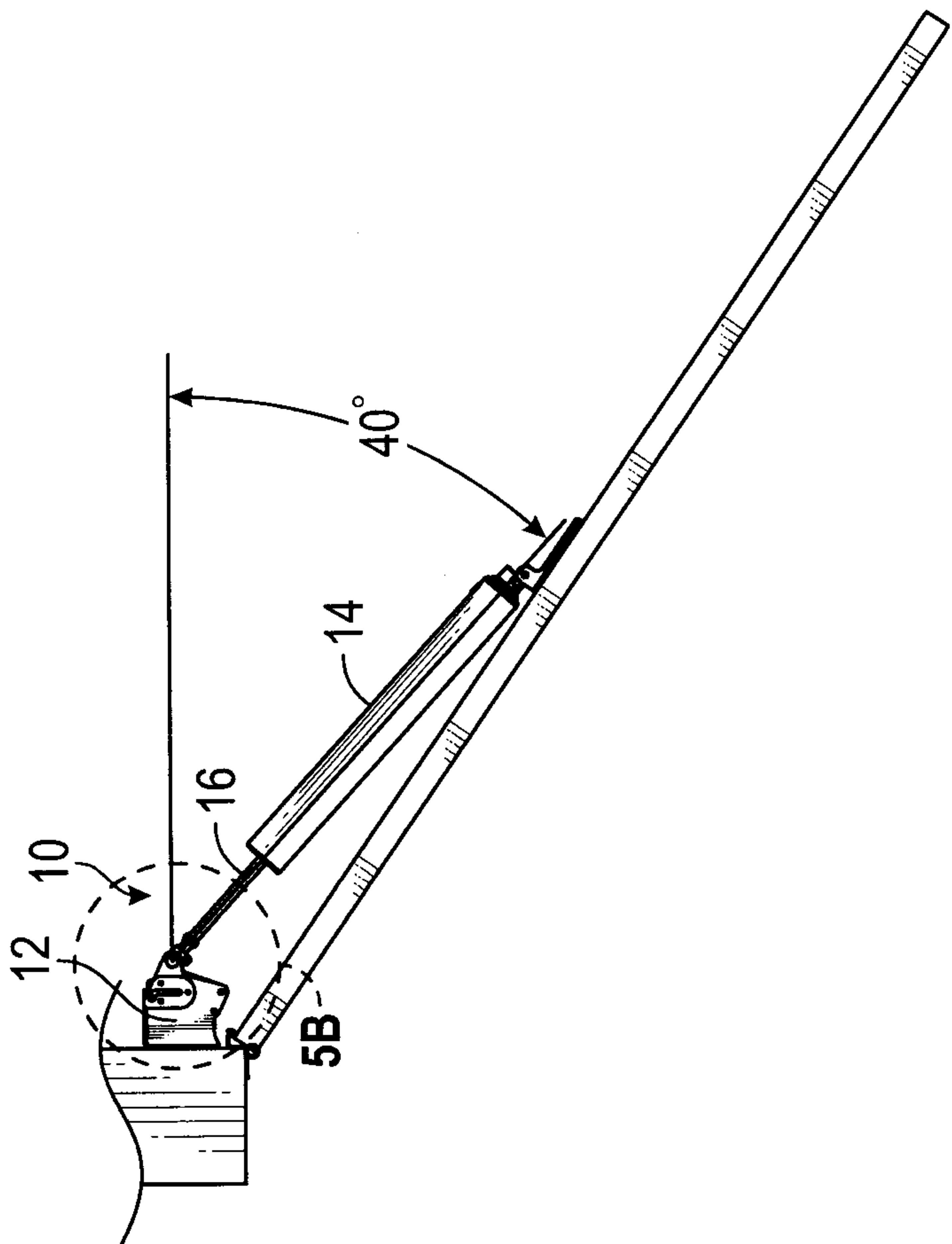

FIG. 4C

7/17



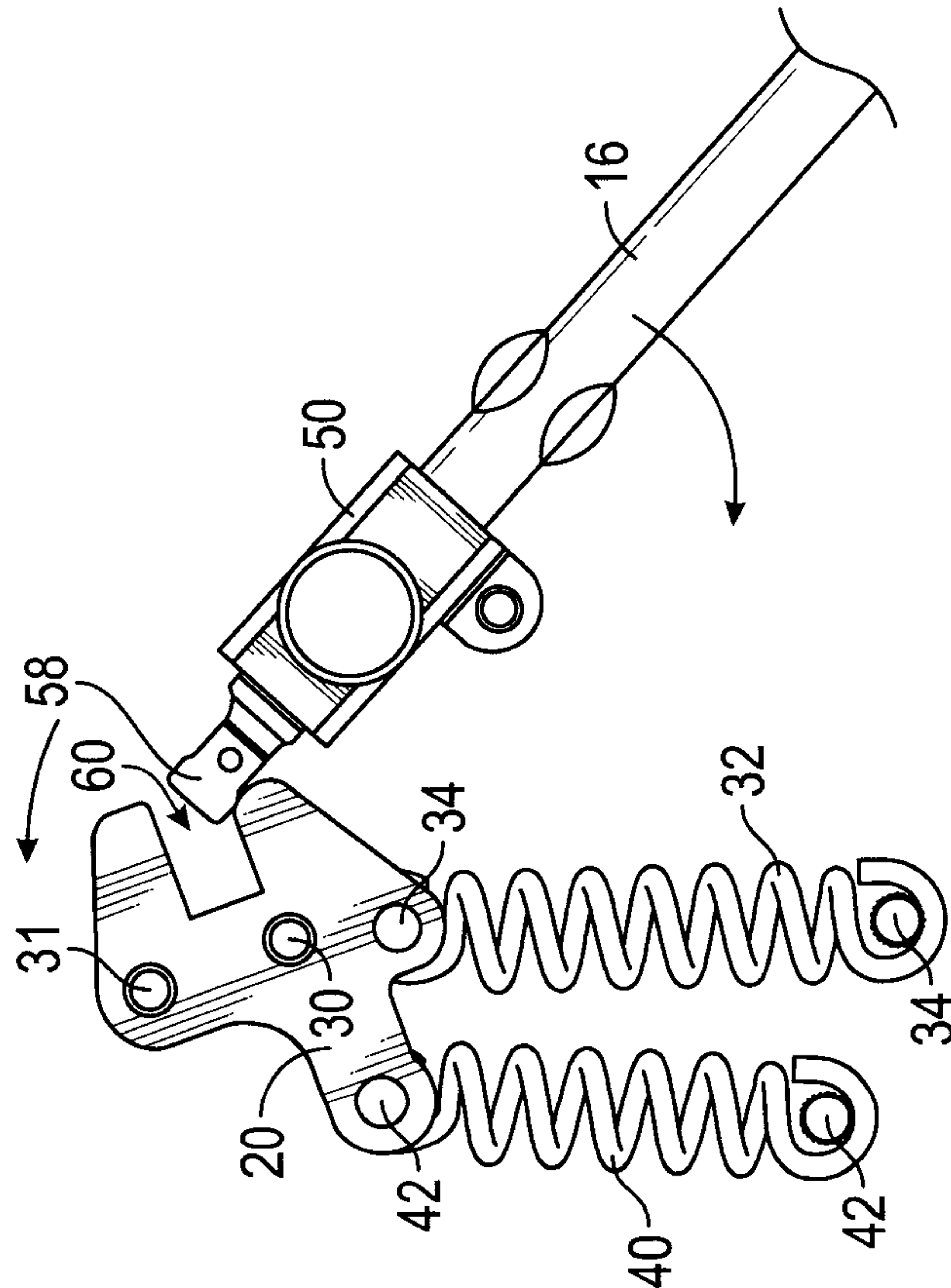

FIG. 5C

9/17

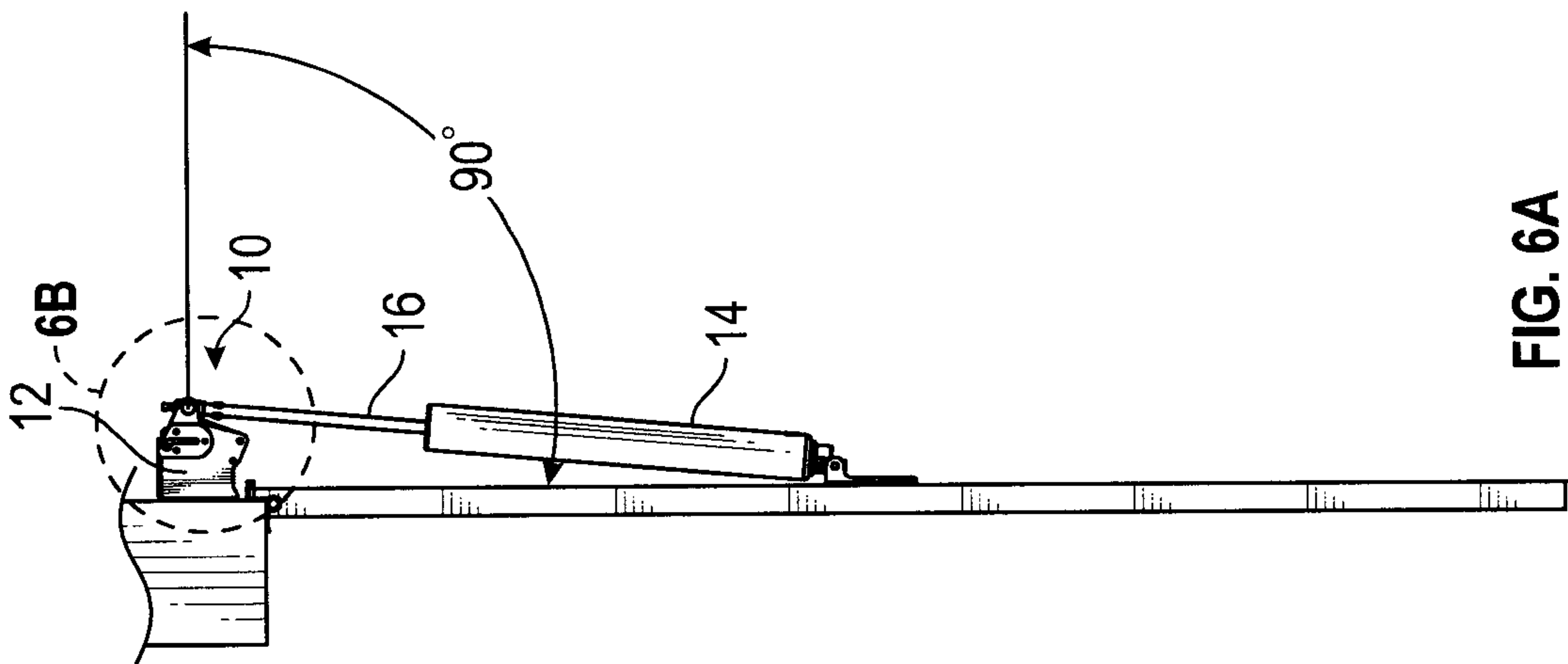

FIG. 6A

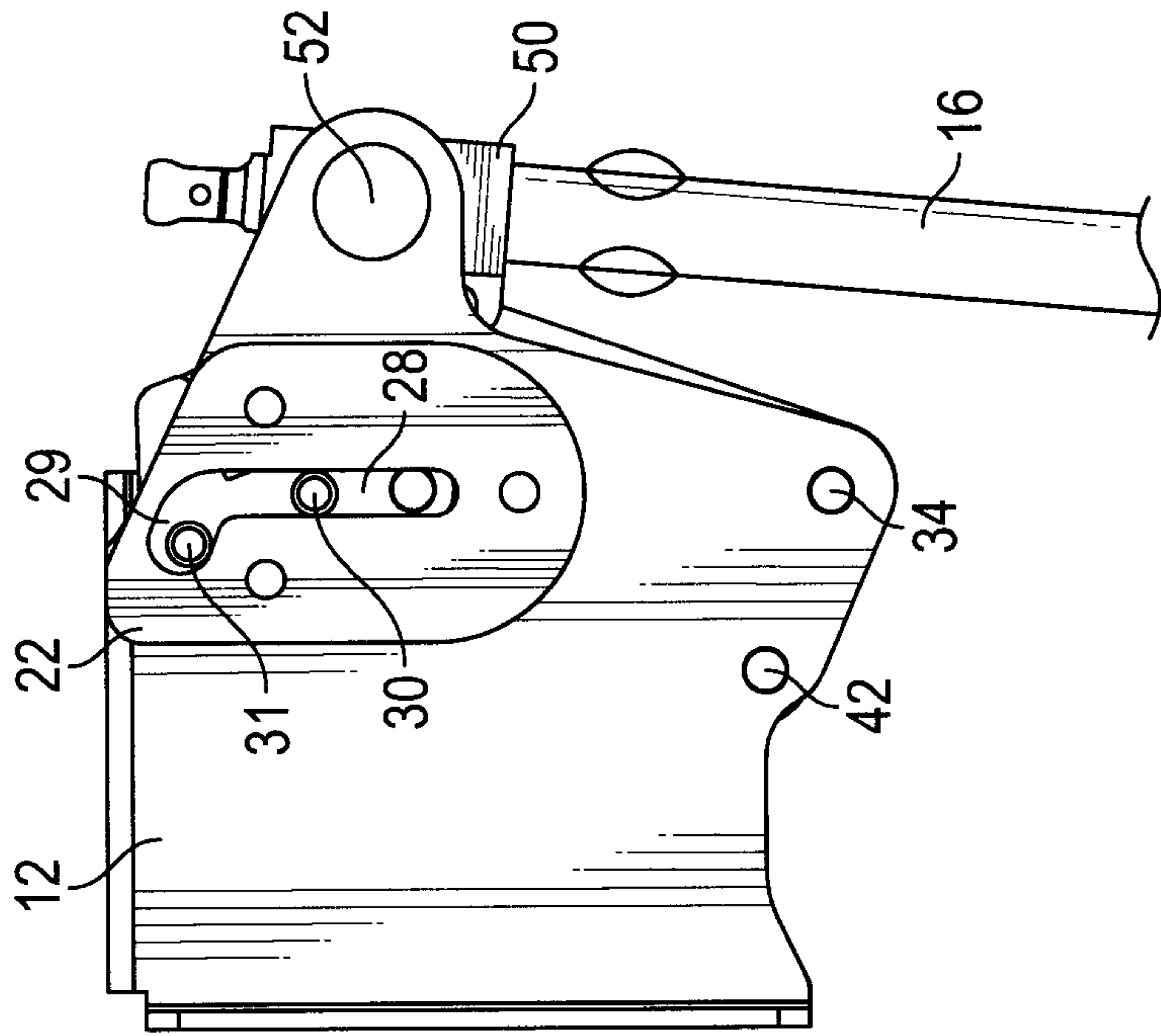

FIG. 6B

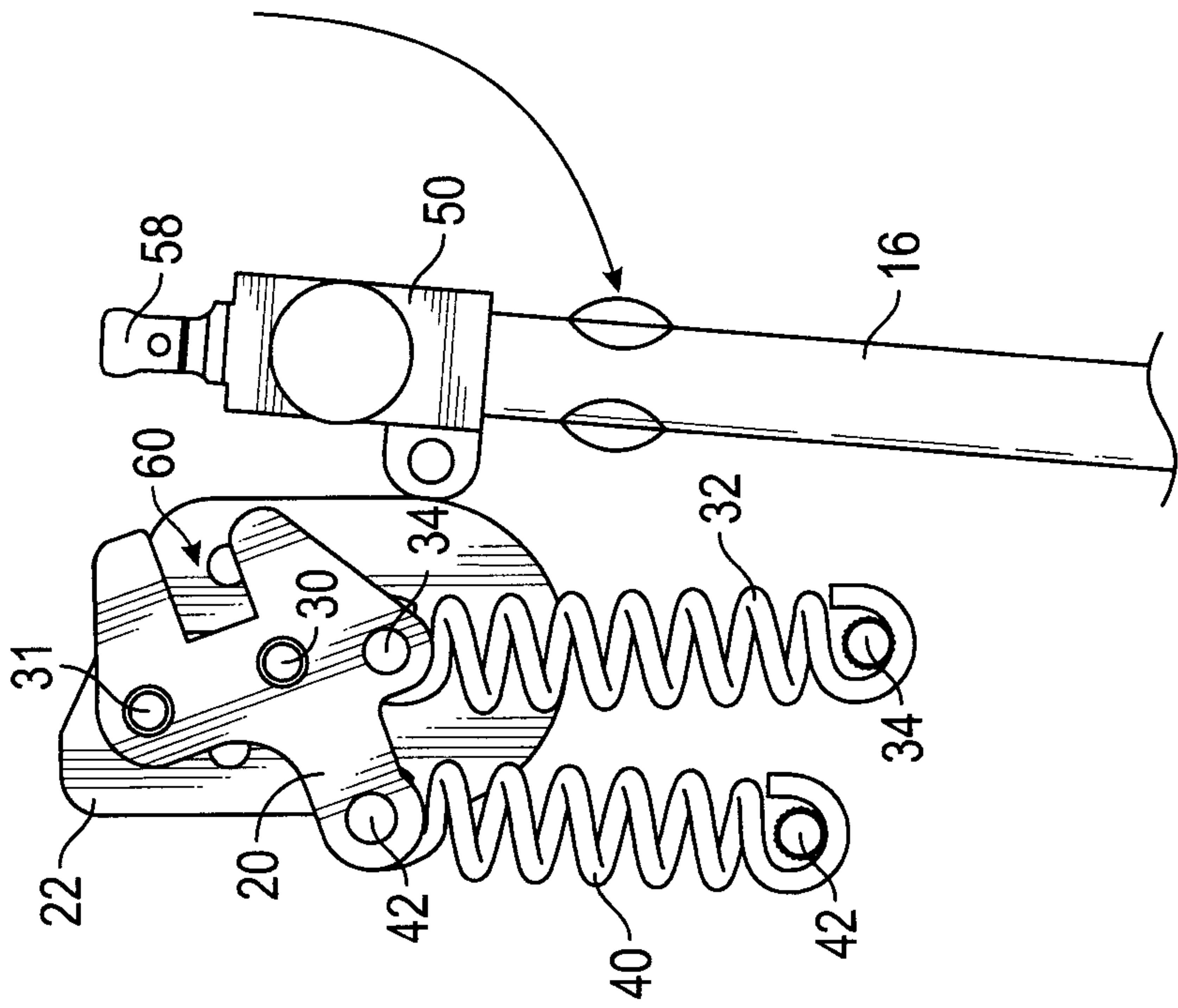

FIG. 6C

11/17

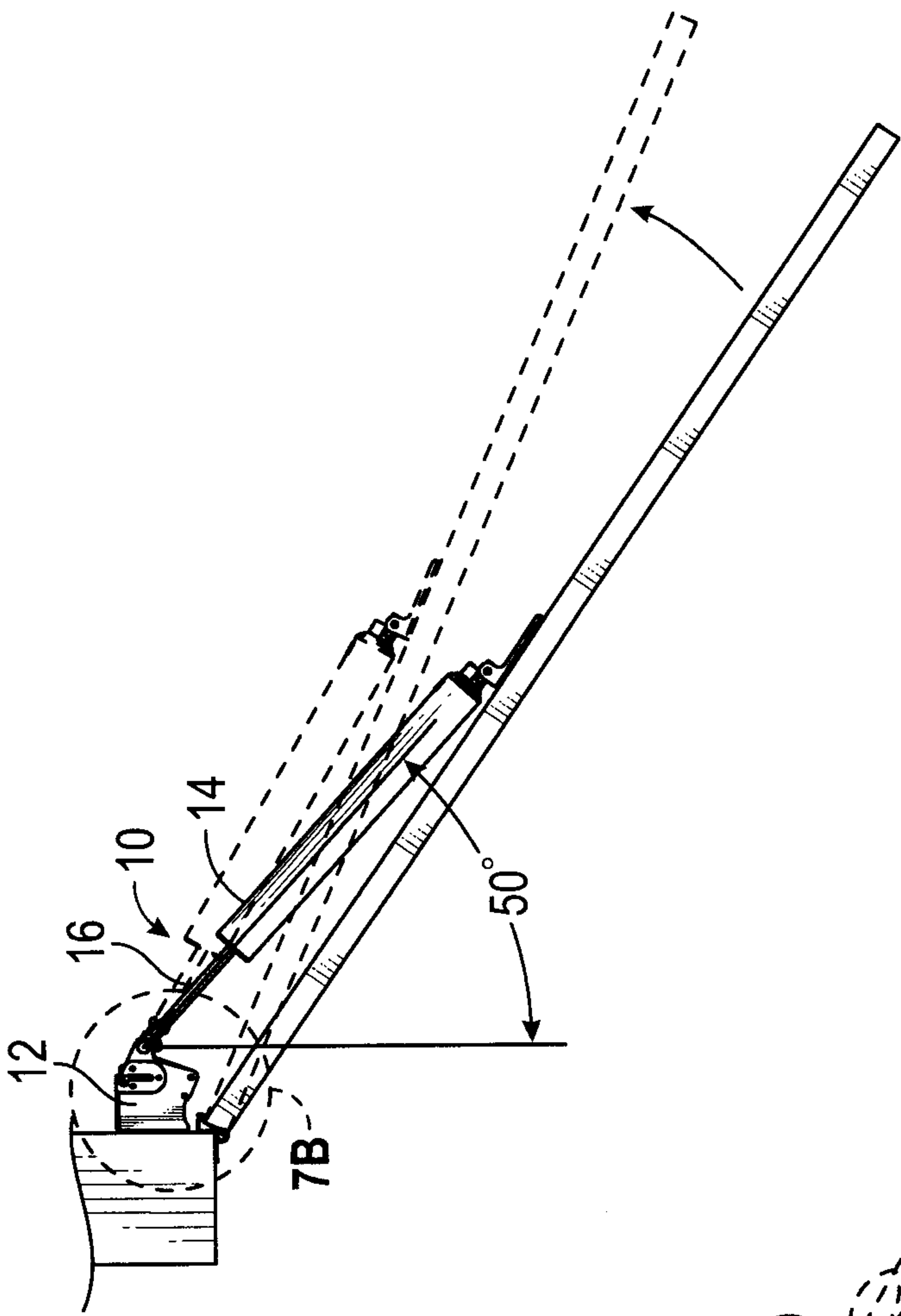

FIG. 7A

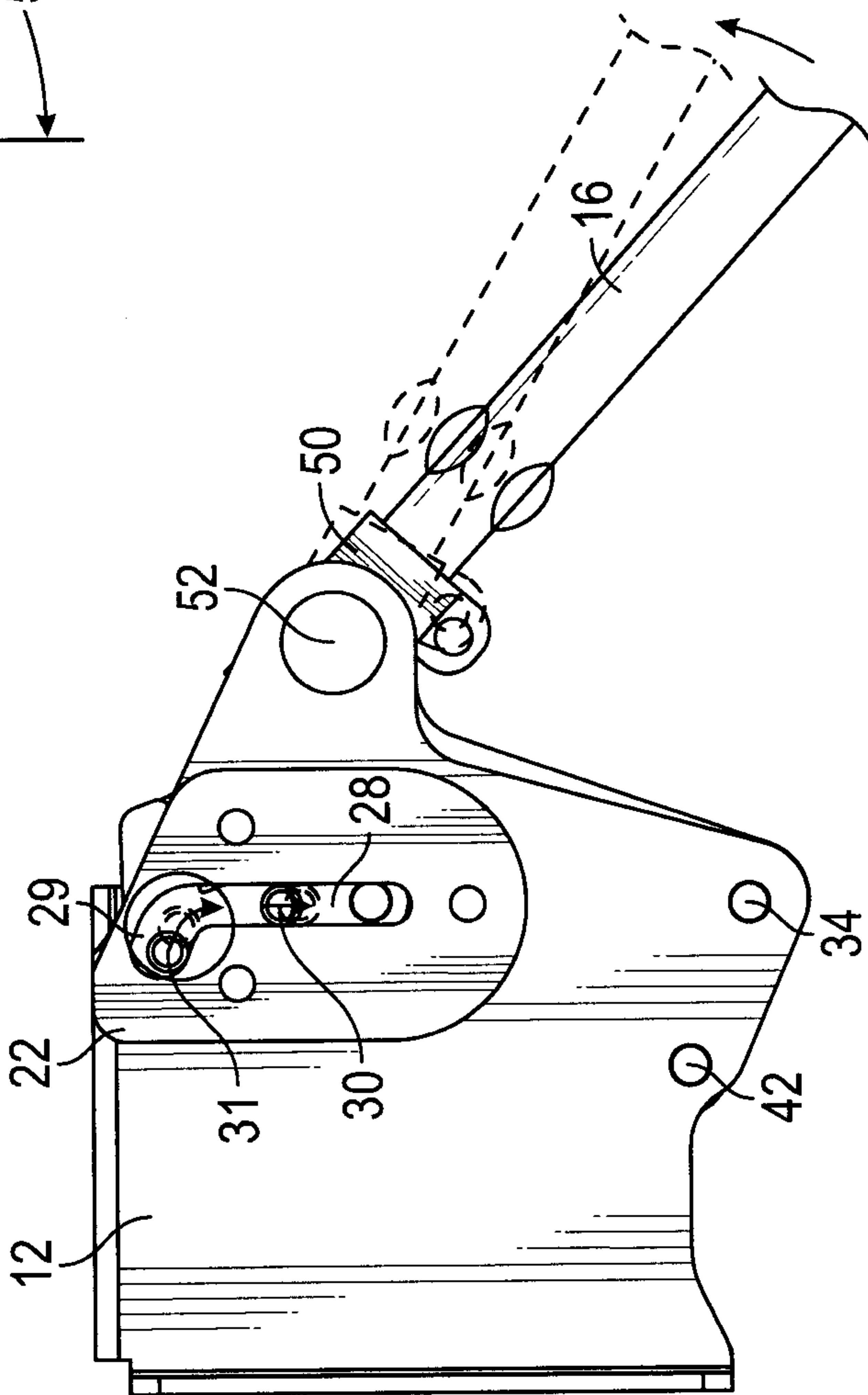

FIG. 7B

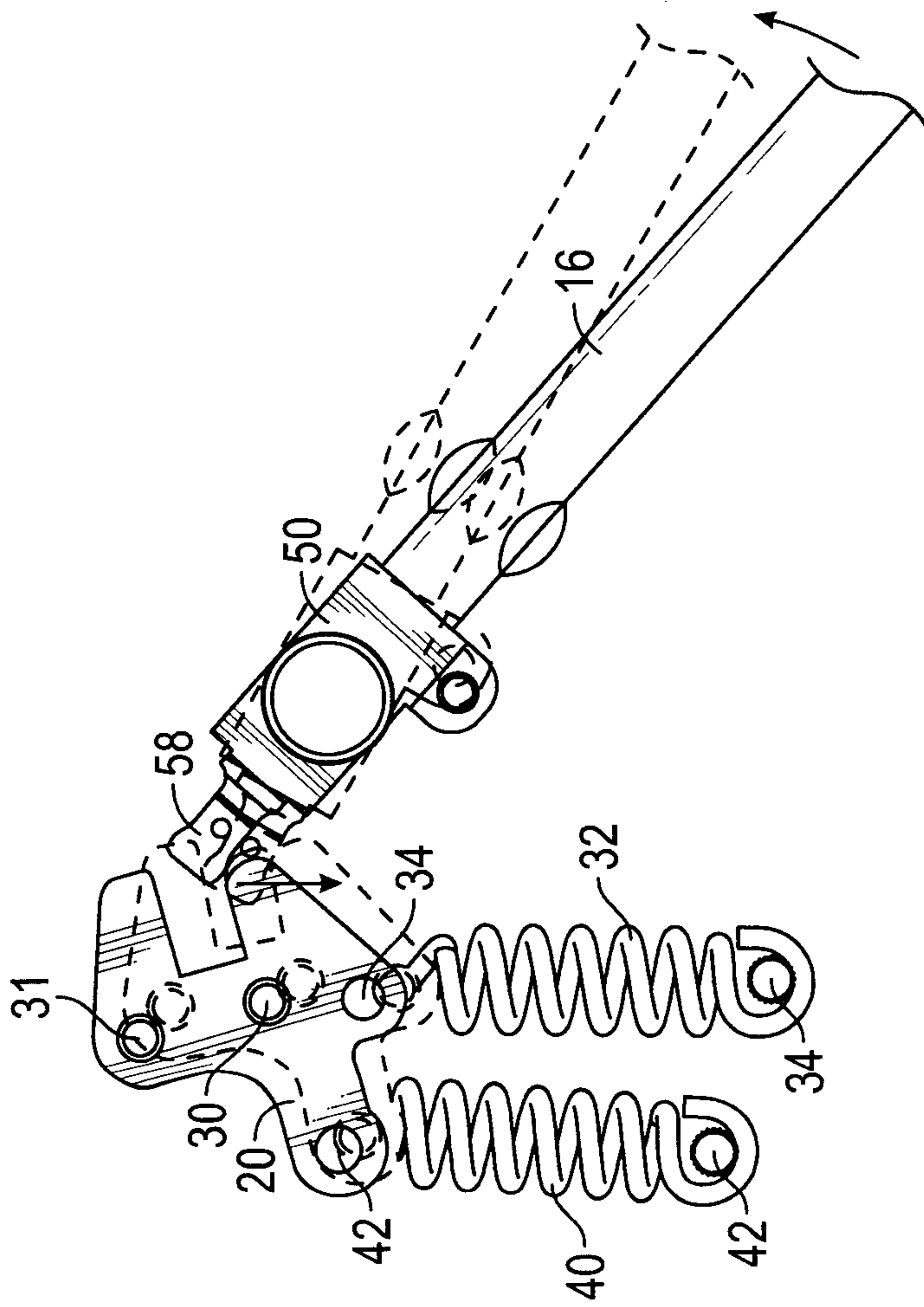

FIG. 7C

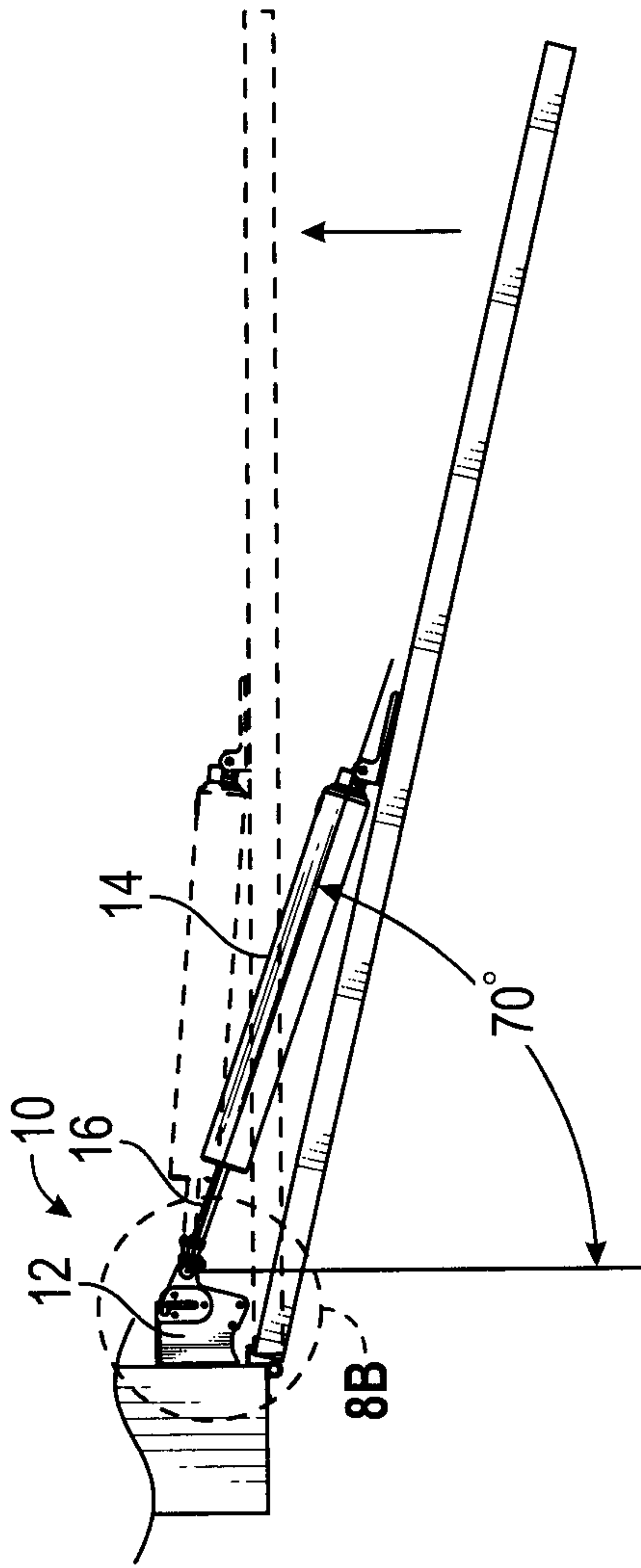

FIG. 8A

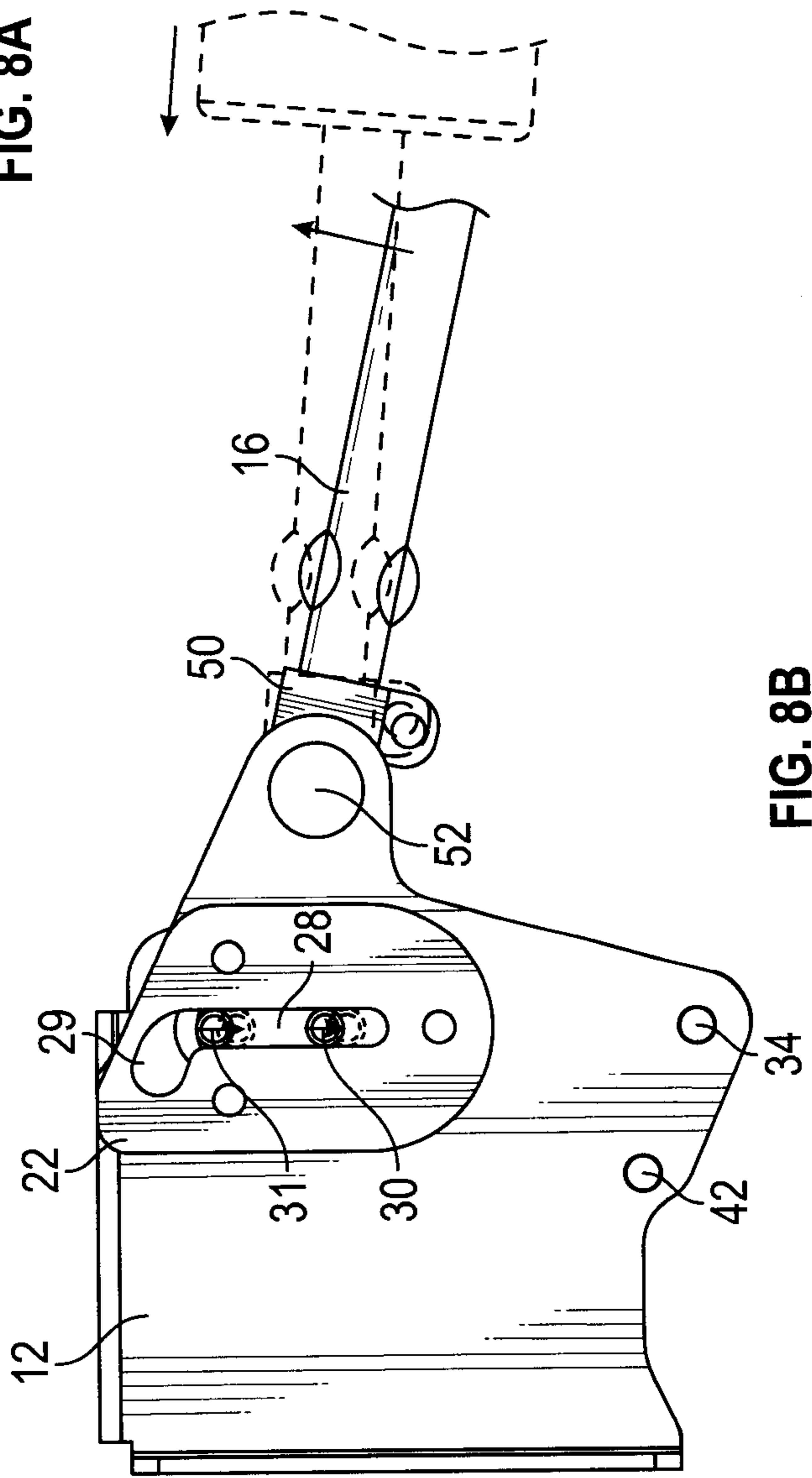

FIG. 8B

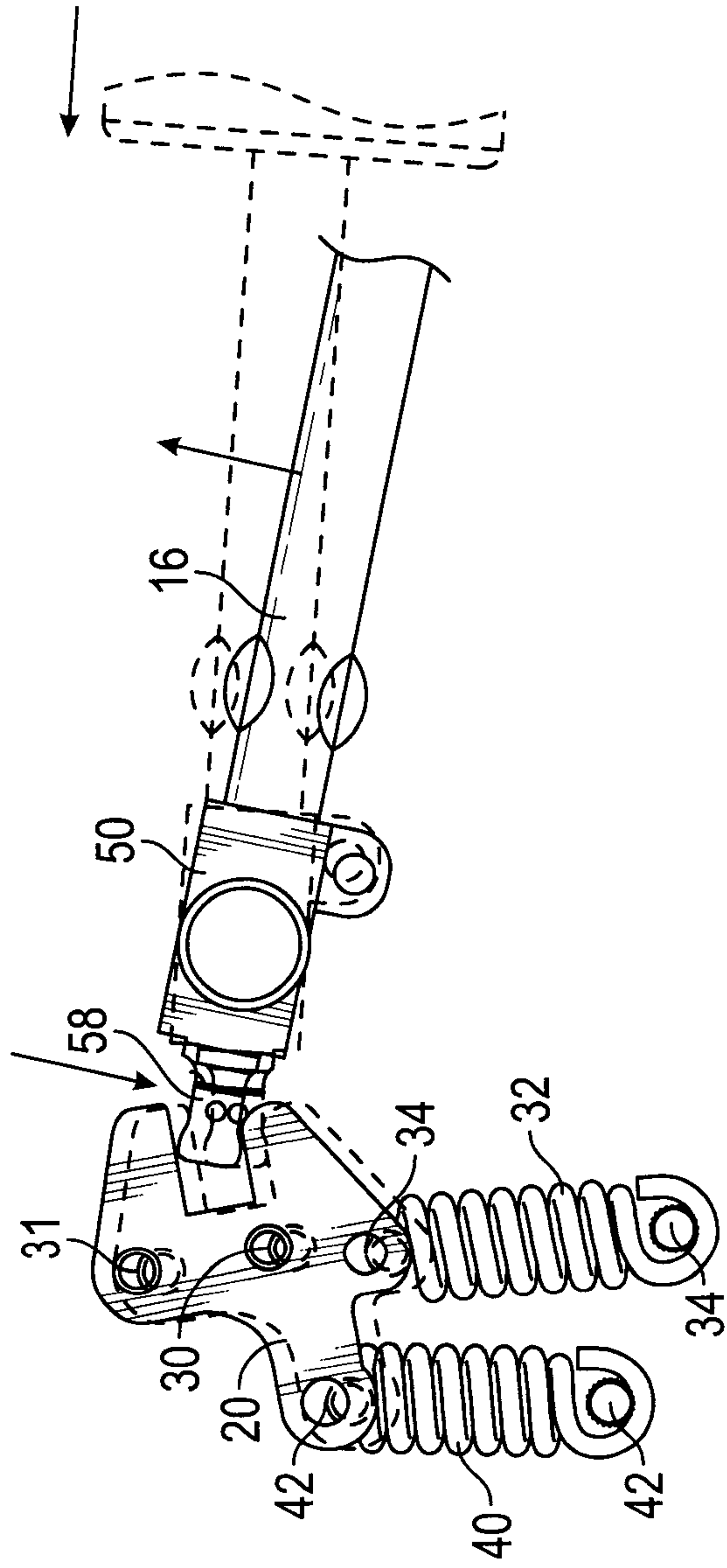

FIG. 8C

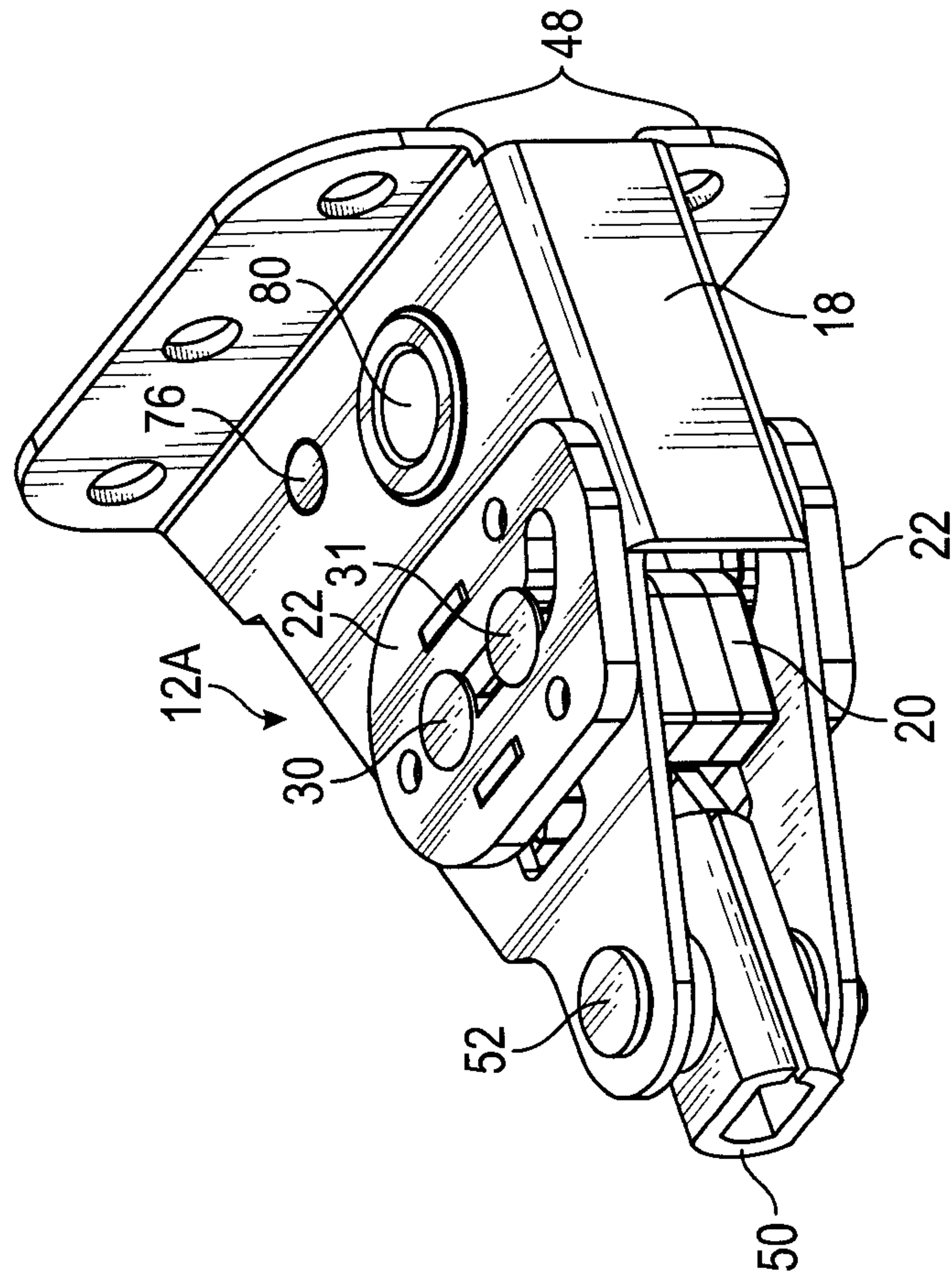

FIG. 9

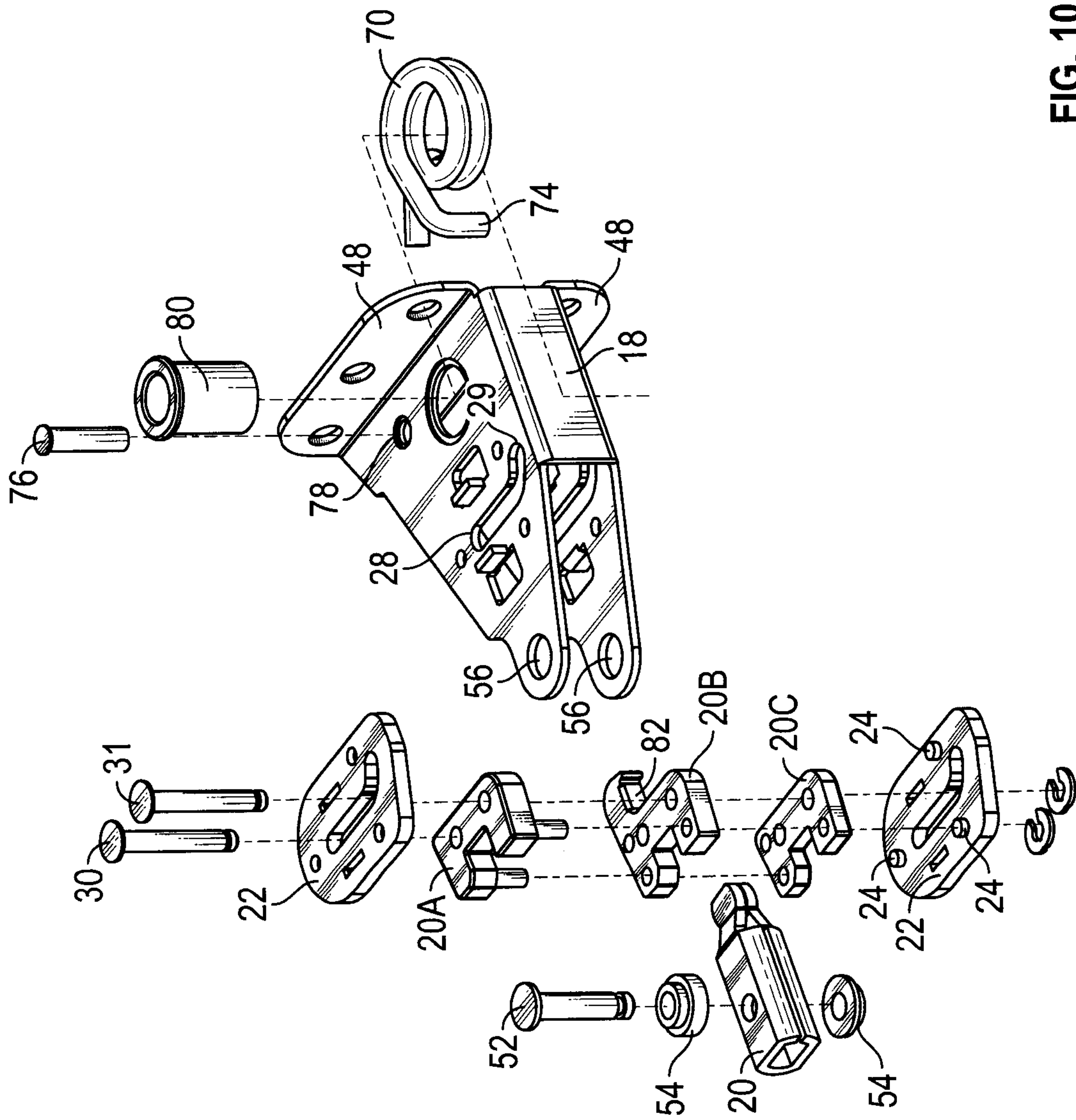

FIG. 10

17/17

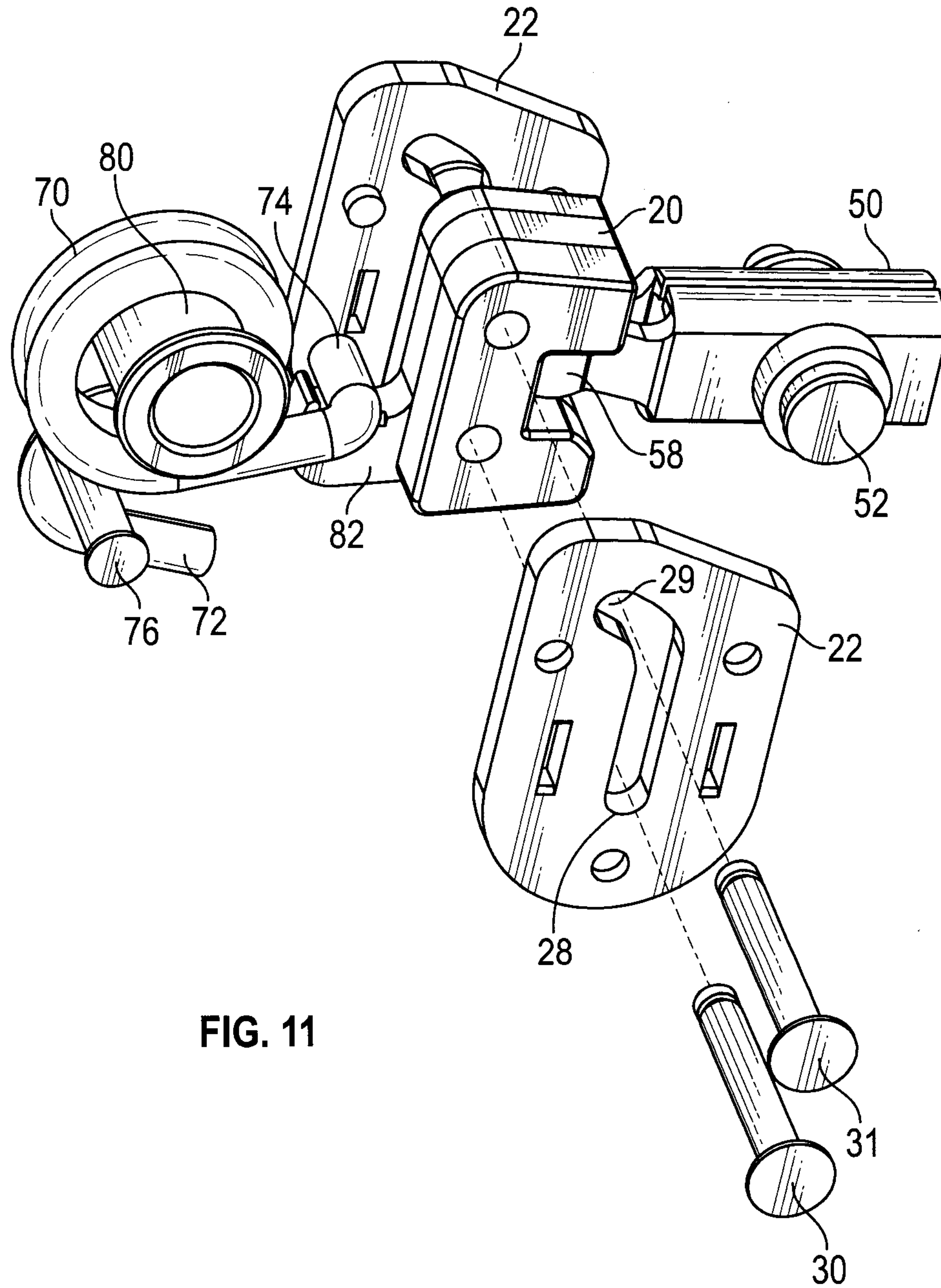

FIG. 11

