

H. REESE.
Wrought-Nail Machines.

No. 133,486.

Patented Nov. 26, 1872.

Fig. 1.

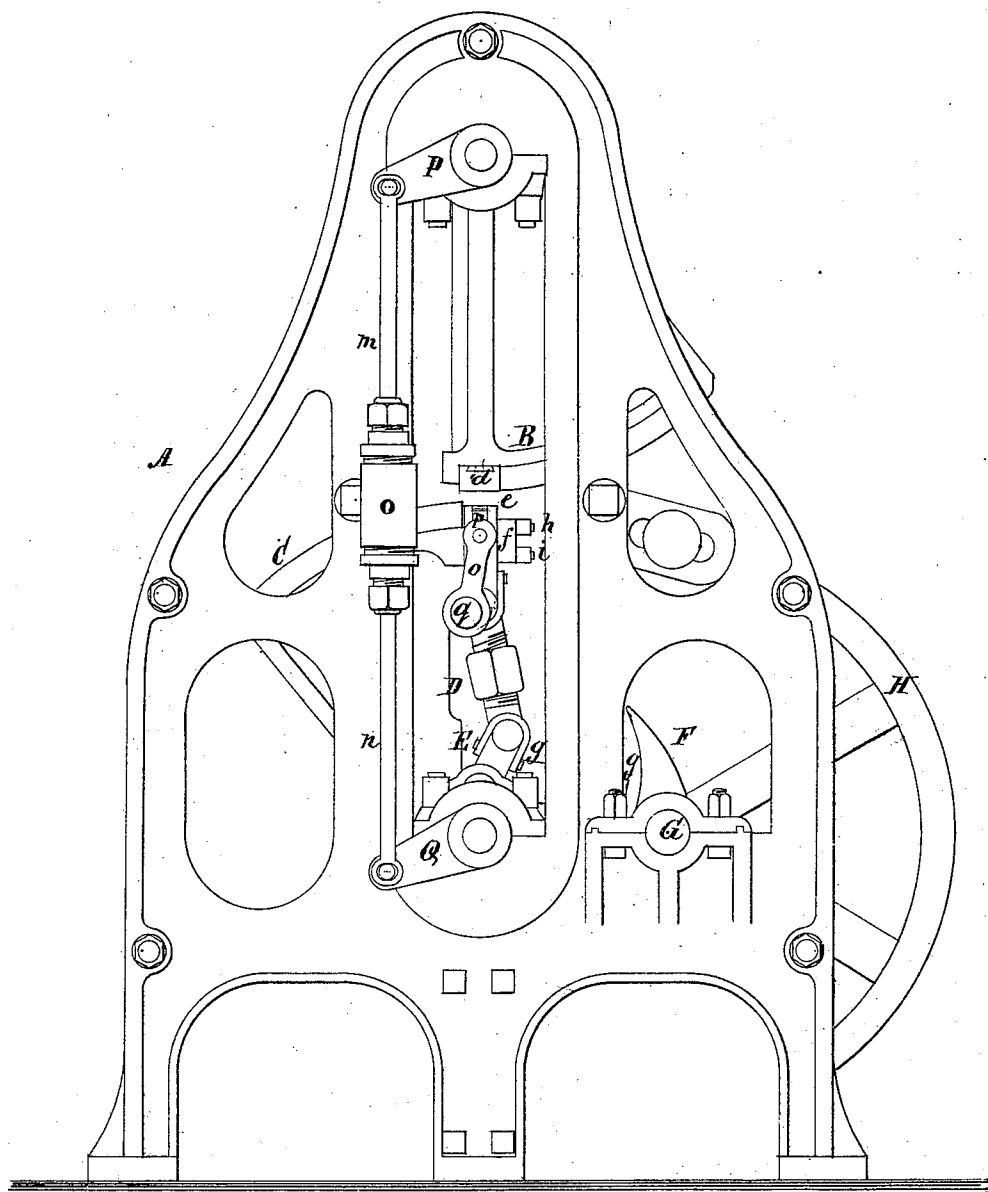

Witnesses:
G. M. Atty
John Kemion

Inventor:
Henry Reese
 PER *Munn & Co.*
printers
 Attorneys.

H. REESE.
Wrought-Nail Machines.

No. 133,486.

Patented Nov. 26, 1872.

Fig. 2.

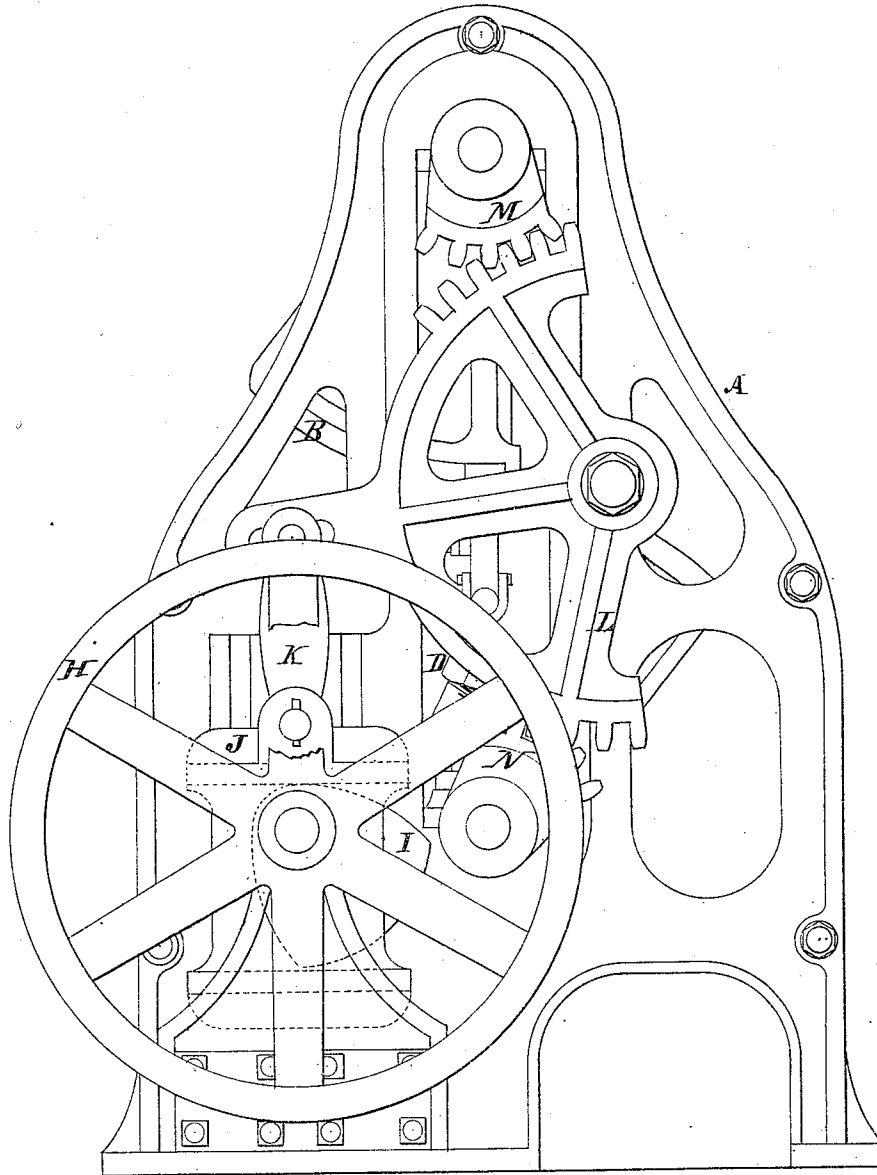

Witnesses:
W. H. Watkins.
John Kemon

Inventor:
Henry Reese
PER Munn & Co
Attorneys.

H. REESE.
Wrought-Nail Machines.

No. 133,486.

Patented Nov. 26, 1872.

Fig. 3.

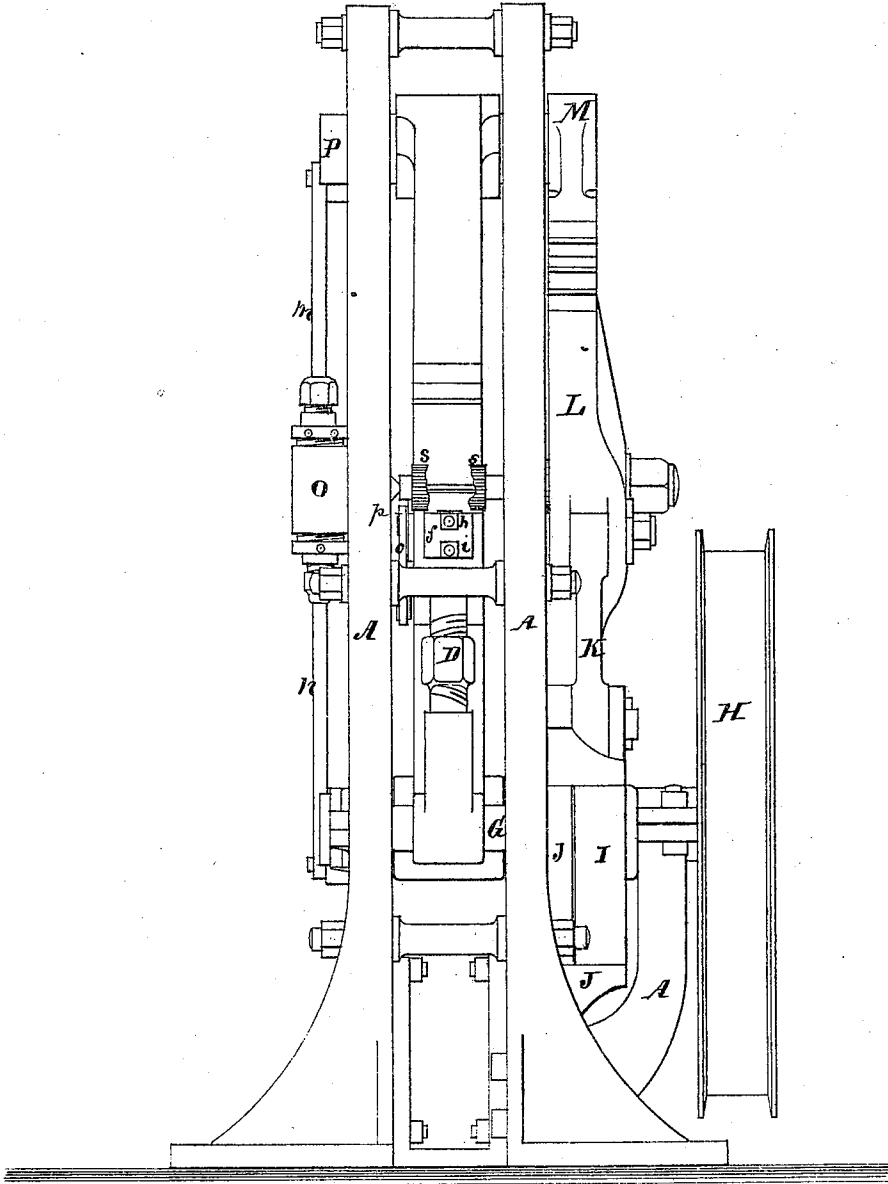

Witnesses:
G. Mathias.
John Remon

Inventor:
Henry Reese
 PER *Munroe & Co.*
for Att.
 Attorneys.

H. REESE.
Wrought-Nail Machines.

No. 133,486.

Patented Nov. 26, 1872.

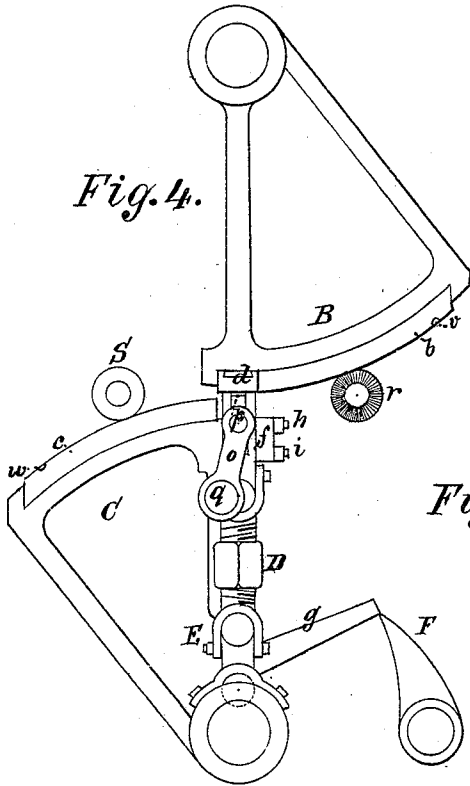

Fig. 4.

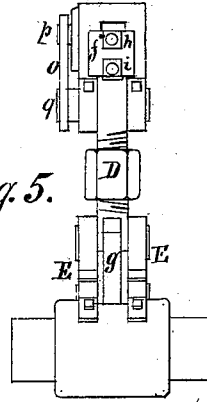

Fig. 5.

Fig. 6.

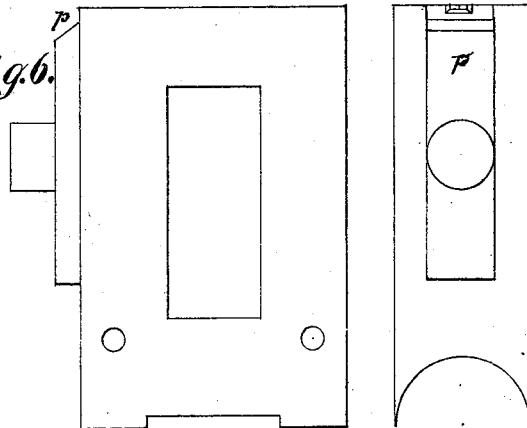

Fig. 7.

Fig. 10.

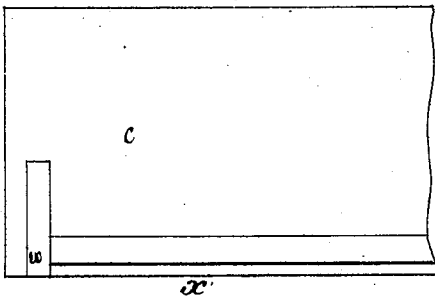

Fig. 8.

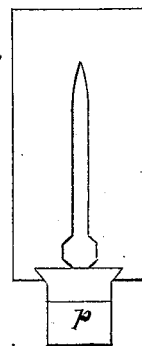

Fig. 11.

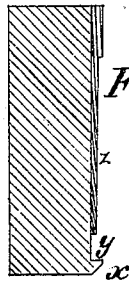

Fig. 9.

Witnesses:
G. Watkins
John C. Remon

Inventor:

Henry Reese

PER *Munn & Co*
for Hart
Attorneys.

UNITED STATES PATENT OFFICE.

HENRY REESE, OF BALTIMORE, MARYLAND.

IMPROVEMENT IN WROUGHT-NAIL MACHINES.

Specification forming part of Letters Patent No. 133,486, dated November 26, 1872.

To all whom it may concern:

Be it known that I, HENRY REESE, of Baltimore city, in the county of Baltimore and State of Maryland, have invented an Improved Nail-Machine, of which the following is a specification:

The invention relates to the method of making wrought-nails by preliminarily drawing the end of a heated rod into a round pointed blank, between two surfaces moving in reverse directions, but with the same velocity, and then shaping said blank between dies. The invention consists in the mode of applying the cut-off attachment, the brushes or sponges, and the shock-spring, as hereinafter described, and also the combination of the various parts for the purpose intended, as shown.

In the drawing, Figure 1 is a side view; Fig. 2, view from the opposite side of Fig. 1; Fig. 3, end view. Figs. 4 to 11 are detail views.

A represents the frame of the machine, and B C the upper and lower sectors. *b c* are plates which are attached to the convex surfaces of the sectors, and one of whose sides constitutes the working-face of each. *x* are opposite raised edges running the entire length of these faces, for the purpose of preventing the rod from being drawn too far between them. These edges make an annular groove around the rod, where the nail is afterward severed, and thus effect the desired purpose. *y* is a groove in the length of the face, deep enough to allow the part of the rod which runs in it to retain its full diameter to form the head of the nail. *z* is a peculiar shape of face adapted to draw out the rod. D E are the toggle-arms by which the lower die *e* is moved toward or from the upper die *d*. *g* is a lever connecting toggle with a cam, F, on a shaft, G. By this mechanism the toggle is operated so as to raise the die *e*, which slides on and is guided by a projection on sector C, while it is kept in place by a plate, *f*, and bolts *h i*. H is a band-wheel whose shaft G has a cam, I, which raises and lowers the slide J. K is a connecting-rod pivoted at one end to slide J, and at the other to the toothed sector L, which gears with pinion-sectors M N arranged on the shafts of sectors B C. O is a close air-cylinder, in which works a piston on one or both of the rods *m n*. These rods are pivoted to arms P Q of the shafts of the vibrating sectors A B. This air-cylinder O affords an air-spring upon which pressure

produces a constantly-increasing resistance, and, being interposed between the connected sectors, takes up part of their momentum, when they suddenly stop. The shock which always occurs at the stoppage is thus to a very great extent avoided. A spiral or other equivalent spring may be substituted for this. *p* represents a steel cutter that slides vertically in dovetailed grooves on the side of die *e*, and is operated by an eccentric, *q*, and rod *o*, while *r s* are brushes or wet sponges that clean or cool the operating-faces of the sectors A B. *v w* are transverse grooves on plates *b c*, which together form a cylindrical opening to receive heated end of metal rod, of which so much only is inserted as is necessary for the contemplated nail.

The operation is as follows: In the drawing the machine is represented as having just completed a nail, and the cam I is in a position to raise slide J. This has the effect of operating the sectors L M N, and vibrating sectors B C until the points *v w* are in coincidence. The cam I now reverses the motion of slide J and sectors L M N, which causes the curved faces *b c* of reversely-moving sectors B C to roll that part of rod which has been placed in grooves *v w* between them, and thus forces longitudinally a wave of heated metal. This lengthens and reduces the end of rod into a long-pointed blank. Just as this is accomplished the nail-shaping dies *d e* are brought opposite to each other, the lower die *e* is raised, and the heated blank pressed into the required form. The cutter *p* now severs the finished nail from the rod, the cam F abandons the lever *g*, the die *e* is let down to its lowest point, the sectors B C are put into their other position, and the nail drops from the machine completed.

Having thus described my invention, what I claim as new, and desire to secure by Letters Patent, is—

1. The cutter *p*, applied in the die *e* and operated as and for the purpose described,
2. The combination, with the drawing-faces *b c* and dies *d e*, of the brushes or sponges *r s*, arranged as and for the purpose set forth.
3. The air-cylinder O, interposed between the connected sectors A B, as and for the purpose specified.

HENRY REESE.

Witnesses:

JNO. E. REESE, Jr.,
THOS. L. REESE.