



- (51) **International Patent Classification:**  
*F16F 1/18* (2006.01)      *F16F 1/02* (2006.01)
- (21) **International Application Number:**  
PCT/GB2024/051963
- (22) **International Filing Date:**  
26 July 2024 (26.07.2024)
- (25) **Filing Language:** English
- (26) **Publication Language:** English
- (30) **Priority Data:**  
2311638.7      28 July 2023 (28.07.2023)      GB
- (71) **Applicant:** NOTTINGHAM TRENT UNIVERSITY [GB/GB]; 50 Shakespeare Street, Nottingham Nottinghamshire NG1 4FQ (GB).
- (72) **Inventors:** AFAZOV, Shukri; C/o Nottingham Trent University, 50 Shakespeare Street, Nottingham Nottinghamshire NG1 4FQ (GB). MANSFIELD, Neil; C/o Not-

tingham Trent University, 50 Shakespeare Street, Nottingham Nottinghamshire NG1 4FQ (GB). **GOY, Damien**; C/o Nottingham Trent University, 50 Shakespeare Street, Nottingham Nottinghamshire NG1 4FQ (GB). **MITCHELL, Iain**; C/o Nottingham Trent University, 50 Shakespeare Street, Nottingham Nottinghamshire NG1 4FQ (GB).

(74) **Agent:** WILSON GUNN; Centurion House, 129 Deansgate, Manchester M3 3WR (GB).

(81) **Designated States** (unless otherwise indicated, for every kind of national protection available): AE, AG, AL, AM, AO, AT, AU, AZ, BA, BB, BG, BH, BN, BR, BW, BY, BZ, CA, CH, CL, CN, CO, CR, CU, CV, CZ, DE, DJ, DK, DM, DO, DZ, EC, EE, EG, ES, FI, GB, GD, GE, GH, GM, GT, HN, HR, HU, ID, IL, IN, IQ, IR, IS, IT, JM, JO, JP, KE, KG, KH, KN, KP, KR, KW, KZ, LA, LC, LK, LR, LS, LU, LY, MA, MD, MG, MK, MN, MU, MW, MX, MY, MZ, NA, NG, NI, NO, NZ, OM, PA, PE, PG, PH, PL, PT, QA, RO, RS, RU, RW, SA, SC, SD, SE, SG, SK, SL, ST, SV, SY, TH,

(54) **Title:** RESILIENT BIASING DEVICE

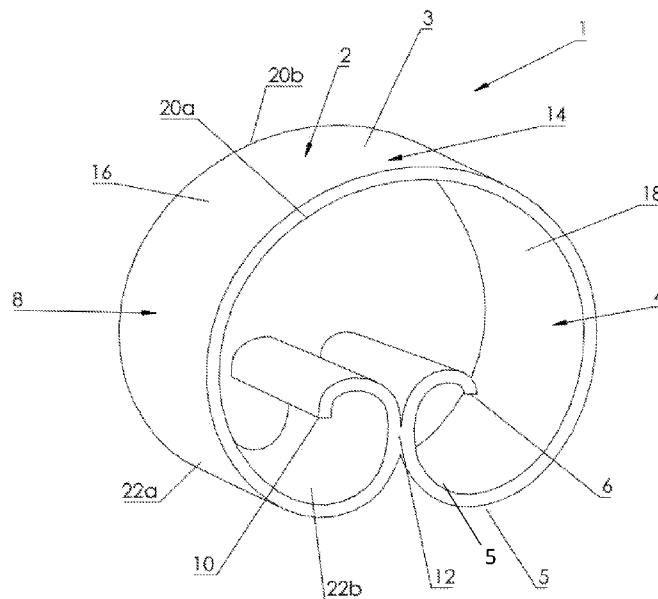

Fig. 1

(57) **Abstract:** This invention provides for a resilient biasing device (1;101;201;301;401;501;601;701) comprising: a unitary body comprising a central portion from which extends a first inwardly curving portion (4;104;204;304;404;504;604;704) comprising a first end (6;106;206;306;406;506;606;706) and a second inwardly curving portion (8;108;208;308;408;508;608;708) comprising a second end (10;110;210;310;410;510;610;710); wherein the first inwardly curving portion and the second inwardly curving portion are directly or indirectly connected together or contact each other at a connection position (12;112;212;312;412;512;612;712) set in from the first and second ends.



TJ, TM, TN, TR, TT, TZ, UA, UG, US, UZ, VC, VN, WS,  
ZA, ZM, ZW.

- (84) Designated States** (*unless otherwise indicated, for every kind of regional protection available*): ARIPO (BW, CV, GH, GM, KE, LR, LS, MW, MZ, NA, RW, SC, SD, SL, ST, SZ, TZ, UG, ZM, ZW), Eurasian (AM, AZ, BY, KG, KZ, RU, TJ, TM), European (AL, AT, BE, BG, CH, CY, CZ, DE, DK, EE, ES, FI, FR, GB, GR, HR, HU, IE, IS, IT, LT, LU, LV, MC, ME, MK, MT, NL, NO, PL, PT, RO, RS, SE, SI, SK, SM, TR), OAPI (BF, BJ, CF, CG, CI, CM, GA, GN, GQ, GW, KM, ML, MR, NE, SN, TD, TG).

**Published:**

- *with international search report (Art. 21(3))*

## **RESILIENT BIASING DEVICE**

### Technical Field of the Invention

The present invention relates to a resilient biasing device, an article comprising a resilient biasing device and a method of storing elastic potential energy.

### 5 Background to the Invention

Typical resilient biasing devices include mechanical springs with different geometrical shapes including helical springs, conical springs, torsional springs, leaf springs and disc springs. Typical resilient biasing devices are often only stretchable or compressible in one direction and therefore cannot provide multidirectional or  
10 multiaxial elastic energy storage potential, suspension or stabilisation.

Multidirectional elastic energy storage potential, suspension or stabilisation can be advantageous in a number of scenarios such as stabilising an article or a person in a moving vehicle, or earthquake proofing an object or a building, or storing elastic energy for example in tidal power facilities wherein the forces impacting the resilient biasing  
15 device may come from more than one direction.

It would therefore be advantageous to create a resilient biasing device which is capable of storing elastic energy when deformed by a force in more than one direction  
It would be advantageous to create a resilient biasing device which is capable of storing elastic energy when twisted, compressed or stretched by a force in more than one  
20 direction.

It would be advantageous to create a resilient biasing device which can be easily scalable such that it can be used in a variety of applications.

It would be advantageous to create a resilient biasing device which provides a higher maximum force within an elastic operational regime of the material. It would be advantageous to create a resilient biasing device which provides a higher elastic potential energy.

5 It would be advantageous to create a resilient biasing device which can be produced in a cost-effective way using a wide range of manufacturing technologies.

It would be advantageous to create a resilient biasing device with less material than prior art devices, reducing weight and its CO<sub>2</sub> footprint.

10 It is an aim of embodiments of the invention to overcome one or more problems of the prior art, whether expressly disclosed herein or not.

#### Summary of the Invention

According to a first aspect of the invention there is provided a resilient biasing device comprising; a unitary body comprising a central portion from which extend a first inwardly curving portion comprising a first end and a second inwardly curving portion comprising a second end; wherein the first inwardly curving portion and the second inwardly curving portion are directly or indirectly connected together or contact each other at a connection position set in from the first and second ends.

20 The first and second ends may comprise free ends. The first and second ends may be joined.

The first inwardly curving portion, central portion and second inwardly curving portion are preferably contiguous on the unitary body.

The height of the resilient biasing device may be defined as the distance from the central portion to the furthest point away from the central portion of the first or second inwardly curving portion or the top-to-bottom distance. The vertical axis or vertical direction is defined as the top to bottom direction along the height of the resilient biasing device.

The length of the resilient biasing device may be defined as the distance from the outermost point of the first inwardly curving portion to the outermost point of the second inwardly curving portion or the side-to-side distance. The longitudinal axis or longitudinal direction is defined as the side-to-side direction along the length of the resilient biasing device.

The width of the resilient biasing device may be defined as the distance from the front face of the resilient biasing device to the back face of the resilient biasing device. The lateral axis or lateral direction is defined as the front-to-back direction along the width of the resilient biasing device.

The resilient biasing device of the invention may be advantageous as it may be compressed, twisted or stretched in a vertical, a lateral and/or a longitudinal direction due to the first and second inwardly curving portions and the connection position set in from the first and second ends; therefore, the resilient biasing device may be advantageous in applications wherein multidirectional suspension, stabilisation or elastic potential energy storage and/or elastic potential energy recovery are required. The resilient biasing device of the invention may be advantageous as it may change its shape under tension and/or compression; therefore, the resilient biasing device may be

advantageous in application wherein multidirectional fastening or connection of two items is required.

In some embodiments the first inwardly curving portion comprises a first spiral.

In some embodiments the second inwardly curving portion comprises a second spiral.

5 In some embodiments the first inwardly curving portion comprises a first spiral and the second inwardly curving portion comprises a second spiral. The first spiral may be planar or flat. The second spiral may be planar or flat. The first spiral and the second spiral may be planar or flat.

10 A “spiral” is defined as a curve which emanates from a point, moving further away from the point as it revolves around the point. In the present invention the first and second spirals may curve from the central portion inwardly and towards a first end and a second end respectively.

The central portion may be a central point or a central line. The central line may be a straight line or a curved line. This embodiment may be advantageous because the  
15 central line may be used as a mounting point for a load.

The central portion may be equidistant from the first and second ends and/or be equidistant from the connection position. The central point may be equidistant from the first and second ends and/or be equidistant from the connection position.

20 In some embodiments the first inwardly curving portion and/or the second inwardly curving portion may comprise a logarithmic spiral. In some embodiments the first inwardly curving portion and/or the second inwardly curving portion may comprise an Archimedean spiral. In some embodiments the first inwardly curving portion and/or the second inwardly curving portion may comprise an Euler spiral. In some

embodiments the first inwardly curving portion and/or the second inwardly curving portion may comprise a hyperbolic spiral.

In preferred embodiments the first inwardly curving portion and/or the second inwardly curving portion may comprise a Fibonacci spiral or a golden spiral. This embodiment may be advantageous because it retains a high elastic limit in the vertical, lateral and longitudinal directions. This embodiment may be advantageous because it provides a spring constant or force constant thereby leading to a high restoring force and a high restoring elastic energy. This embodiment may be advantageous because the Fibonacci or golden spirals can provide an exact mathematical solution enabling the central portion and the connection position to lay on the same line (180 degrees); hence providing smooth transition at the central portion (with no stress concentrations) and improved stability compared to other spirals. This embodiment may be advantageous in some manufacturing processes (e.g. rolling) because the Fibonacci or golden spirals change the radius every 90 degrees compared to other spirals, hence it is easier to control the manufacturing process.

In some embodiments the first inwardly curving portion is curved in a clockwise direction and the second inwardly curving portion is curved in an anti-clockwise direction. In other embodiments the first inwardly curving portion is curved in an anti-clockwise direction and the second inwardly curving portion is curved in a clockwise direction. The direction of the curve is defined by the direction in which the curve rotates from the unitary body towards the end.

In some embodiments the first inwardly curving portion and the second inwardly curving portion are asymmetrical. In some embodiments the first inwardly

curving portion and the second inwardly curving portion are symmetrical. Embodiments wherein the first and second inwardly curving portions are symmetrical may be advantageous because they may allow the resilient biasing device to be symmetrically compressed, stretched or twisted which may lead to even stabilisation, suspension or elastic potential energy storage within the resilient biasing device.

The first inwardly curving portion and the second inwardly curving portion may be directly connected together or directly contact each other at the connection position set in from the first and second ends. The first inwardly curving portion and the second inwardly curving portion may be fixedly directly connected together or fixedly directly contact each other. The first inwardly curving portion and the second inwardly curving portion may be detachably directly connected together or detachably directly contact each other. The first inwardly curving portion and the second inwardly curving portion may be directly connected together by welding or formed integrally. In some embodiments the first and second inwardly curving portions are integrally connected or formed at the connection position. In other embodiments the first and second inwardly curving portions are joined together at the connection position.

The first and second inwardly curving portions may be indirectly connected at the connection position set in from the first and second ends via a connecting member. The first and second inwardly curving portions may contact each other at the connection position, such as by abutment or touching and may be indirectly connected via a connecting member. The first and second inwardly curving portions may be spaced apart from each other and indirectly connected via a connecting member. The connecting member may be connected to any point on the first inwardly curving portion and any point on the second inwardly curving portion. The first and second inwardly

curving portions may be spaced apart from each other and indirectly connected via a connecting member wherein the connecting member may be connected to the first inwardly curving portion at a point located in from the first end and connected to the second inwardly curving portion at a point located in from the second end. The first inwardly curving portion and the second inwardly curving portion may be indirectly connected via an integrally formed connecting member. The first inwardly curving portion and the second inwardly curving portion may be indirectly connected via a separate connecting member such as a bracket, a plate, a ring or a bar. The first inwardly curving portion and the second inwardly curving portion may be fixedly indirectly connected together. The first inwardly curving portion and the second inwardly curving portion may be detachably indirectly connected together.

In some embodiments the connection position is located at least three quarter turns into the first inwardly curving portion wherein the quarter turns are counted from the central portion on the unitary body. In some embodiments the connection position is located at least three quarter turns into the second inwardly curving portion wherein the quarter turns are counted from the central portion on the unitary body. The connection position may be advantageous because it allows the spring to be compressed or stretched without the resilient biasing device being damaged if it is stretched beyond its elastic limit. The connection position may be advantageous because it may be used as a mounting point or for suspending a load without the requirement of an additional mounting point. The connection position may be advantageous because it allows the spring to be compressed or stretched vertically and/or longitudinally without the first inwardly curving portion and the second inwardly curving portion moving apart from each other which in turn may result in the spring becoming damaged as it is stretched

beyond its elastic limit. The connection position is also advantageous because it allows the spring to be stretched or twisted laterally without the first inwardly curving portion and the second inwardly curving portion moving apart from each other which in turn may result in the spring becoming damaged as it is stretched. The connection position  
5 therefore creates a resilient biasing device comprising a high elastic limit in the lateral, longitudinal and vertical directions.

In some embodiments the unitary body comprises a circular, ellipsoidal, triangular, quadrilateral, pentagonal or hexagonal cross section. In some embodiments the unitary body may be hollow. In some embodiments the unitary body may be solid.  
10 In some embodiments the unitary body may be porous. In some embodiments the unitary body may comprise a lattice structure. In some embodiments the unitary body may comprise a lattice structure surrounded by a solid outer layer. In some embodiments the unitary body comprises a wire. In some embodiments the unitary body comprises a tube. In some embodiments the unitary body comprises a strip. The strip  
15 may be solid, hollow or porous. At least a portion of the strip may comprise a lattice structure. The strip may comprise a quadrilateral cross-section. The strip may comprise a rectangular cross-section comprising two opposed long edges and two opposed short edges wherein the length of the long edges is the width of the unitary body, and the length of the short edges is the thickness of the unitary body/strip.

20 The width of the unitary body may be on the lateral axis. The width of the unitary body may be constant. This embodiment may be advantageous because it may result in the resilient biasing device comprising a controlled stiffness.

The width of the unitary body may be variable. This embodiment may be advantageous because it may result in the resilient biasing device comprising a controlled point of weakness should the resilient biasing device be required to purposefully break in use.

- 5           The device may be scalable in size such that it could any order of magnitude from nanoscale to kilo-scale. The device may be scalable in at least one of the longitudinal, lateral or vertical direction. The device may be scalable in at least one of the longitudinal, lateral or vertical direction by different scales.

The unitary body may be on the nanoscale, microscale or larger.

- 10           The width of the unitary body may be at least 1 mm. The width of the unitary body may be at least 2 mm, 3 mm, 4 mm, 5 mm, 6 mm, 7 mm, 8 mm, 9 mm or at least 10 mm. The width of the unitary body may be at least 2 cm, 5 cm, 10 cm, 20 cm, 50 cm, 75 cm 1 m, 2 m, 5 m, 7 m or at least 10 m.

- 15           The thickness of the unitary body may be at least 0.5 mm. The thickness of the body may be at least 1 mm, 2 mm, 4 mm, 6 mm, 8 mm, 10 mm, 15 mm, 20 mm, 25 mm, 50 mm, 75 mm or at least 100 mm.

- 20           The height of the resilient biasing device may be on the vertical axis. The height of the resilient biasing device may be at least 1 cm. The height of the resilient biasing device may be at least 2 cm, 5 cm, 7 cm, 10 cm, 15 cm, 20 cm, 25 cm, 30 cm, 50 cm, 75 cm, 1 m, 2 m, 5 m, 7 m or at least 10 m.

The length of the resilient biasing device may be on the longitudinal axis. The length of the resilient biasing device may be at least 1 cm. The length of the resilient

biasing device may be at least 2 cm, 5 cm, 7 cm, 10 cm, 15 cm, 20 cm, 25 cm, 30 cm, 50 cm, 75 cm, 1 m, 2 m, 5 m, 7 m or at least 10 m.

The unitary body may comprise a front face and a back face. The unitary body may comprise a strip wherein the strip may comprise a front face and a back face. In  
5 some embodiments the front face of the first inwardly curving portion is fixedly connected to the opposing front face of the second inwardly curving portion at a location set in from the ends of each curving portion.

In some embodiments the first inwardly curving portion and/or the second inwardly curving portion each comprise at least three quarter turns before the  
10 connection position wherein the quarter turns are counted from the central portion, central line or the central point on the resilient biasing device. In some embodiments the first inwardly curving portion and/or the second inwardly curving portion each comprise at least 4, 5, or 6 quarter turns before the connection position wherein the quarter turns are counted from the central portion or the central point on the unitary  
15 body.

In some embodiments the first inwardly curving portion comprises between 1 and 7 quarter turns between the connection position and the first end. In some embodiments the first inwardly curving portion comprises between 1 and 6, between 1 and 5, between 1 and 4 or between 1 and 3 quarter turns between the connection position  
20 and the first end. In some embodiments the second inwardly curving portion comprises between 1 and 7 quarter turns between the connection position and the second end. In some embodiments the second inwardly curving portion comprises between 1 and 6, between 1 and 5, between 1 and 4 or between 1 and 3 quarter turns between the

connection position and the second end. In some embodiments the first inwardly curving portion comprises between 1 and 7 quarter turns between the connection position and the first end and the second inwardly curving portion comprises between 1 and 7 quarter turns between the connection position and the second end.

5           In some embodiments the first inwardly curving portion and the second inwardly curving portion are planar parallel such that they are on the same plane.

                  In some embodiments the unitary body comprises a third inwardly curving portion comprising a third end and a fourth inwardly curving portion comprising a fourth end; wherein the third inwardly curving portion and the fourth  
10   inwardly curving portion extend from the central portion and are connected together and connected to the connection point at a point set apart from the third end and the fourth end. The third and fourth inwardly curving portions may be orthogonal to the first and second inwardly curving portions, The first, second, third and fourth inwardly curving portions may form a cruciform configuration. The first, second, third and fourth  
15   inwardly curving portion may be connected together or contact each other at a single connection portion set in from the first, second, third and fourth ends. This embodiment may be advantageous for fastener application. This embodiment may be advantageous for fixing in a hole or a cylindrical cavity as it may fit tightly due to the four inwardly curving portions.

20           In some embodiments the resilient biasing device comprises a further connector, in addition to the connection position, wherein the further connector is located between the connection position and the ends. The further connector may be a bar, a plate, a bracket or a ring. The bar may extend across portions of the first and second inwardly

curving portions between the connection position and the ends of the first and second inwardly curving portions. The further connector may be a bar. The bar may extend across portions of the first and second inwardly curving portions between the connection position and central portion. The further connector may be a joint.

5           The first and second ends may be joined. The joined ends may form an annular or elliptical configuration, which may be circular. A bearing may be connected to the annular joined first and second ends. The annular joined ends and/or the bearing may be configured to receive an axle, in use. This may be advantageous because it may enable the resilient biasing device to rotate in use. This may alternatively be  
10           advantageous because it may enable an axis to rotate within the stationary resilient biasing device in use. In some embodiments the resilient biasing device comprises a piezoelectric device. The piezoelectric device may comprise or be connected to an actuator.

          In some embodiments the resilient biasing device comprises a sensor located at  
15           any point on the resilient biasing device. The sensor may be located at the connection point. The sensor may be located at the further connector. In some embodiments the resilient biasing device comprises a sensor located between the connection position and the ends. The sensor may be selected from the group consisting of: magnetic sensors, light measuring sensors, optical sensors, micro-electromechanical systems and shock  
20           absorbers or any combination thereof. In some embodiments the resilient biasing device may be a sensor, for example by measuring a force exerted onto the resilient biasing device.

The resilient biasing device may comprise a material selected from the group consisting of: a metal or a metal alloy, a polymer, an elastomer, a ceramic, a composite material, a nanomaterial and an organic material or any combination thereof. The resilient biasing device may comprise at least two materials. The resilient biasing device  
5 may comprise a first material at least partially surrounded by a second material. The resilient biasing device may comprise the first material covering at least a portion of at least one surface of the second material. The resilient biasing device may comprise a metal or metal alloy and a polymer. The resilient biasing device may comprise a metal or metal alloy and rubber. The metal or metal alloy may be selected from the group  
10 consisting of: stainless steel, a steel alloy such as chromium-vanadium steel, silicon manganese steel, chrome silicon steel, carbon steel, a nickel alloy, a titanium alloy or a copper alloy or any combination thereof. The metal alloy may be Ti<sub>6</sub>Al<sub>4</sub>V.

The resilient biasing device may comprise a polymer. The polymer may be selected from the group consisting of: acrylic or polymethyl methacrylate (PMMA),  
15 polylactic acid, polycarbonate (PC), polyethylene (PE), polypropylene (PP), polyethylene terephthalate (PETE or PET), polyvinyl chloride (PVC) and acrylonitrile-butadiene-styrene (ABS) or nay combination thereof.

The resilient biasing device may comprise an article connector. The article connector may comprise an aperture through the unitary body. The article connector  
20 may comprise a connector which protrudes from the unitary body. The article connector may protrude from the central portion of the unitary body, from which the first and second inwardly curving portions extend. The article connector may comprise a support on which the article rests, in use. The article connector may be connected to any point on the unitary body. The article connector may be a bar, a plate or a bracket.

According to a second aspect of the invention there is provided an article comprising at least one resilient biasing device of the first aspect of the invention.

The article may be selected from the group consisting of: a building, a vehicle, an item of furniture, a vehicle component, a robotic device, a medical device, an agricultural device, a space travel component or a nautical device. The medical device  
5 may be a prosthetic for a human or an animal. The article may be a piece of sporting equipment. The article may be a system. The system may be a stabilising system, a suspension system or a protection system. The system may be an electronic system. The system may be a micro-electromechanical system (MEMS). The vehicle may be  
10 selected from the group consisting of: a car, a van, a truck, an articulated lorry, an aircraft such as a helicopter or a plane, a submarine, a pushchair or a pram, a cart and a bicycle. The resilient biasing device may be within a landing gear of an aircraft.

The article may be a component of an energy generating system such as a component of a hydropower plant, a water transfer plant or a nuclear power plant. The  
15 article may be a fluid vessel within an energy generating system. The article may be a component of an energy storage system.

The article may be selected from the group consisting of: UAVs, drones, navigational device and military platforms.

At least one resilient biasing device may be located beneath the article. The or  
20 each resilient biasing device may be oriented to support the article from below. At least one resilient biasing device may be located within the article. At least one resilient biasing device may be located on at least one side of the article. At least one resilient biasing device may be located above the article. This may be advantageous as it may

absorb load prior to the load coming into contact with the article thereby protecting the article.

At least one resilient biasing device may be located between two articles. At least one resilient biasing device may be connected between two articles.

5 In some embodiments, in which the resilient biasing device comprises an article connector, the article may be connected to the article connector. The article may be detachably connected or fixedly connected to the resilient biasing device and/or the article connector. In some embodiments, in which the resilient biasing device comprises a joint, the article may be connected to the joint.

10 In some embodiments the article comprises at least 2 resilient biasing devices. The article may comprise at least 3, 4, 5, 10, 15, 20, 25 or at least 30 resilient biasing devices.

According to a third aspect of the invention there is provided a method of storing elastic potential energy comprising applying a force to a resilient biasing device  
15 according to the first aspect of the invention and compressing, stretching or twisting the resilient biasing device.

The resilient biasing device may be within an article according to the second aspect of the invention.

The method may comprise applying the force in a lateral direction. The method  
20 may comprise applying the force in a longitudinal direction. The method may comprise applying the force in a vertical direction. The method may comprise applying the force in a vertical direction and a longitudinal direction at the same time. The method may comprise applying the force in a lateral direction and a longitudinal direction at the

same time. The method may comprise applying the force in a lateral direction and a vertical direction at the same time. The method may comprise applying the force in a vertical direction, a longitudinal direction and a lateral direction at the same time. The method may comprise applying the force in a vertical direction followed by a longitudinal direction. The method may comprise applying the force in a vertical direction followed by a lateral direction. The method may comprise applying the force in a lateral direction followed by a longitudinal direction. The method may comprise applying the force in a lateral direction followed by a vertical direction. The method may comprise applying the force in a longitudinal direction followed by a vertical direction. The method may comprise applying the force in a longitudinal direction followed by a lateral direction.

The force may be applied to opposing sides of the resilient biasing device such that the resilient biasing device may be compressed, stretched and/or twisted.

The method may comprise compressing the resilient biasing device. The method may comprise compressing the resilient biasing device across a single axis or in a single direction. The method may comprise compressing the resilient biasing device across multiple axes or multiple directions. The method may comprise compressing the resilient biasing device across a vertical axis or in a vertical direction. The method may comprise compressing the resilient biasing device across a longitudinal axis or in a longitudinal direction. The method may comprise compressing the resilient biasing device across a vertical and a longitudinal axis or in both a vertical and longitudinal direction.

The method may comprise stretching the resilient biasing device. The method may comprise stretching the resilient biasing device across a single axis or in a single direction. The method may comprise stretching the resilient biasing device across multiple axes or multiple directions. The method may comprise stretching the resilient biasing device across a vertical axis or in a vertical direction. The method may comprise stretching the resilient biasing device across a longitudinal axis or in a longitudinal direction. The method may comprise stretching the resilient biasing device across a vertical and a longitudinal axis.

The method may comprise twisting the resilient biasing device. The method may comprise twisting the resilient biasing device across a single axis or in a single direction. The method may comprise twisting the resilient biasing device across multiple axes or multiple directions. The method may comprise twisting the resilient biasing device across a lateral axis or in a lateral direction.

The resilient biasing device may be formed according to a suitable technique selected from the group consisting of: forging, bending, rolling casting, cutting, hand crafting, wire electrical discharge machining, 3D printing, extrusion and moulding or any combination thereof. The casting may be die casting, sand casting or investment casting. The moulding may be injection moulding or powder injection moulding. The cutting may be milling, laser cutting, jet cutting, plasma cutting, electrical discharge machining or electron beam cutting. The inwardly curving spirals may be joined using welding processes, brazing and/or soldering. The resilient biasing device may undergo a secondary treatment of process to improve the surface finish or improve the ultimate and fatigue strength of the material. The secondary treatment may be a heat treatment,

a hardening process or an aesthetic finishing process. The aesthetic finishing process may be coating, polishing, grinding, finishing and/or brushing.

According to a fourth aspect of the invention there is provided a resilient biasing device comprising; a unitary body comprising a central portion from which extend a  
5 first inwardly curving portion comprising a first end and a second inwardly curving portion comprising a second end; wherein the first inwardly curving portion and the second inwardly curving portion are fixedly connected together at a connection position set in from the first and second ends.

Any of the statements of the first aspect of the invention may apply to the fourth  
10 aspect of the invention with the exception that the first inwardly curving portion and the second inwardly curving portion of the fourth aspect of the invention are fixedly connected together.

According to a fifth aspect of the invention there is provided an article comprising at least one resilient biasing device of the fourth aspect of the invention.

15 Any of the statements of the second aspect of the invention may apply to the fifth aspect of the invention with the exception that the resilient biasing device is of the fourth aspect of the invention.

According to a sixth aspect of the invention there is provided a method of storing elastic potential energy comprising applying a force to a resilient biasing device  
20 according to the fourth aspect of the invention and compressing, stretching or twisting the resilient biasing device.

Any of the statements of the third aspect of the invention may apply to the sixth aspect of the invention with the exception that the resilient biasing device is of the fourth aspect of the invention.

## 5 Detailed Description of the Invention

In order that the invention may be more clearly understood embodiments thereof will now be described, by way of example only, with reference to the accompanying drawings, of which:

- Figure 1 illustrates a perspective view of a first embodiment of a resilient biasing device according to the invention.
- Figure 2 illustrates a side view of a second embodiment of a resilient biasing device of the invention wherein the quarter turns of the first inwardly curving portion and the second inwardly curving portion are illustrated and the ratio of the size of the quarter turns are illustrated.
- Figure 3 illustrates a perspective view of a third embodiment of a resilient biasing device according to the invention.
- Figure 4 illustrates a side view of a fourth embodiment of a resilient biasing device of the invention.
- Figure 5 illustrates a perspective view of a fifth embodiment of a resilient biasing device of the invention.

- Figure 6 illustrates a perspective view of a sixth embodiment of a resilient biasing device of the invention.
- Figure 7 illustrates a perspective view of a seventh embodiment of a resilient biasing device of the invention.
- 5 Figure 8 illustrates a perspective view of an eighth embodiment of a resilient biasing device of the invention.
- Figure 9 illustrates a perspective view of the first embodiment of a resilient biasing device of figure 1 wherein a force, as illustrated by an arrow, is applied in a longitudinal direction.
- 10 Figure 10 illustrates a perspective view of the first embodiment of a resilient biasing device of figure 1 wherein a force, as illustrated by an arrow, is applied in a vertical direction.
- Figure 11 illustrates a perspective view of the first embodiment of a resilient biasing device of figure 1 wherein a force, as illustrated by an arrow, is applied in a lateral direction.
- 15
- Figure 12 illustrated a side view of a first embodiment of an article of the second aspect of the invention wherein the article is a railway suspension system.
- Figure 13 illustrates a testing apparatus used to test the properties of the third  
20 embodiment of a resilient biasing device.

- Figure 14 is a graph which shows experimentally tested force vs displacement for the third embodiment of the resilient biasing device made of Ti<sub>6</sub>Al<sub>4</sub>V under loading and unloading conditions under compressive load.
- 5 Figure 15 is a graph which shows experimentally tested, analytical and simulation force vs displacement data for the third embodiment of the resilient biasing device made of Ti<sub>6</sub>Al<sub>4</sub>V under loading and unloading conditions under compressive load.
- 10 Figure 16 is a graph which shows analytical and simulation (FEA) data for the stiffness as the thickness increases of the third embodiment of the resilient biasing device as the height (h) is changed.
- Figure 17 is a graph which shows analytical and simulation (FEA) data for the maximum displacement that the third embodiment of the resilient biasing device reaches before the elastic limit is reached.
- 15 Figure 18 is a graph which shows simulation (FEA) data for the maximum force that the third embodiment of the resilient biasing device reaches before the elastic limit is reached.
- 20 Figure 19 is a graph which shows simulation (FEA) data for force vs displacement for the third embodiment of the resilient biasing device (height of 64 mm, width of 20 mm and thickness of 3 mm) made of Ti<sub>6</sub>Al<sub>4</sub>V under loads in the vertical (tension and compression), longitudinal and lateral directions before the elastic limit is reached.

A first embodiment of the resilient biasing device (1) according to the first aspect of the invention is illustrated in figure 1.

The resilient biasing device (1) comprises a unitary body (2) comprising a central portion in the form of a central point (3) from which extends a first inwardly curving portion (4) comprising a first end in the form of a first free end (6) and a second inwardly curving portion (8) comprising a second end in the form of a second free end (10); wherein the first inwardly curving portion (4) and the second inwardly curving portion (8) are directly fixedly connected together at a connection position (12) set in from the first (6) and second free ends (10). The first inwardly curving portion (4) and second inwardly curving portion (8) comprise Fibonacci spirals. The first inwardly curving portion (4) and second inwardly curving portion (8) comprise 3 quarter turns before the connection position (12).

The unitary body (2) comprises a strip (14) comprising a front face (16) and a back face (18). The strip (14) comprises a rectangular cross section comprising two short edges (20a, 20b) and two long edges (22a, 22b). The length of the short edges (20a, 20b) defines the thickness of the resilient biasing device (1). The length of the long edges (22a, 22b) defines the width of the resilient biasing device (1). The height of the resilient biasing device (1) is defined as the length from the central point (3) of the unitary body (2) to the furthest point (5) of the first inwardly curving portion (4).

The connection position (12) is located on the front face of the strip (16) at the third quarter turn of the first inwardly curving portion (4) and the third quarter turn of the second inwardly curving portion (8) wherein the quarter turns are counted from the central point (3). The connection position (12) is located on the front face of the strip

(16) two quarter turns from the first free end (6) and two quarter turns from the second free end (10).

Figure 2 illustrates a side view of a second embodiment of a resilient biasing device (101) and shows the quarter turns and the ratio of the arc radius lengths  
5 corresponding to the quarter turns. The resilient biasing device (101) of Figure 2 is identical to the device of Figure 1 except that the device (101) of Figure 2 comprises a first inwardly curving portion (104) comprising a Fibonacci spiral comprising 8 quarter  
10 turns and a second inwardly curving portion (108) comprising a Fibonacci spiral comprising 8 quarter turns. The first inwardly curving portion (104) and the second inwardly curving portion (108) are symmetrical. The first inwardly curving portion (104) and the second inwardly curving portion (108) comprise 3 quarter turns before the connection position (112) and 5 quarter turns after the connection position (112),  
between the connection position (112) and free ends (106, 110).

A third embodiment of a resilient biasing device (201) according to the first  
15 aspect of the invention is illustrated in figure 3.

The resilient biasing device (201) comprises a unitary body (202) comprising a central point (203) from which extends a first inwardly curving portion (204) comprising a first free end (206) and a second inwardly curving portion (208) comprising a second free end (210); wherein the first inwardly curving portion (204)  
20 and the second inwardly curving portion (208) are directly fixedly connected together at a connection position (212) set in from the first (206) and second free ends (210).

The resilient biasing device of the third embodiment of the invention (201) is essentially the same as the resilient biasing device of the first embodiment of the

invention (1) with the exception that the resilient biasing device of the third embodiment of the invention (201) comprises a further connector (24). The further connector (24) comprises a bar located between and integrally formed above the connection position (212) and the free ends (206, 210). Between the further connector  
5 (24) and the connection point (212) there is an aperture (26) suitable for inserting an axis or a bar, for example.

A fourth embodiment of a resilient biasing device (301) of the invention is illustrated in figure 4. The resilient biasing device (301) comprises a unitary body (302) comprising a central point (303) from which extends a first inwardly curving portion  
10 (304) comprising a first end (306) and a second inwardly curving portion (308) comprising a second end (310); wherein the first inwardly curving portion (304) and the second inwardly curving portion (308) are directly fixedly connected together at a connection position (312) set in from the first (306) and second ends (310). The first end (306) and the second end (310) are connected to form a connector in the form of an  
15 annular member (70) with a central aperture (72). Within the annular member (70) there is a bearing (74). The bearing (74) is suitable for connecting to an axle.

A fifth embodiment of a resilient biasing device (401) of the invention is illustrated in figure 5. The resilient biasing device (401) comprises a unitary body (402) comprising a central point (403) from which extends a cruciform configuration  
20 comprising a first inwardly curving portion (404) comprising a first free end (406), a second inwardly curving portion (408) comprising a second free end (410), a third inwardly curving portion (76) comprising a third free end (78) and a fourth inwardly curving portion (80) comprising a fourth free end (82); wherein the first inwardly curving portion (404), the second inwardly curving portion (408), the third inwardly

curving portion (76) and the fourth inwardly curving portion (80) are directly fixedly connected together at a connection position (412) set in from the first (406), second (410), third (78) and fourth (82) free ends. This embodiment is advantageous for use in holes or circular cavities because due to the four inwardly curving portions, the device  
5 may fit securely within the circular cavity.

A sixth embodiment of a resilient biasing device (501) of the invention is illustrated in figure 6. The resilient biasing device (501) comprises a unitary body (502) comprising a central point (503) from which extends a first inwardly curving portion (504) comprising a first free end (506) and a second inwardly curving portion (508)  
10 comprising a second free end (510); wherein the first inwardly curving portion (504) and the second inwardly curving portion (508) are indirectly connected together at a connection position (512) set in from the first (506) and second (510) free ends; wherein the connection point (512) comprises a plate (84). This embodiment may be advantageous because it may allow a sensor or another device to be placed on the plate  
15 (84).

A seventh embodiment of a resilient biasing device (601) of the invention is illustrated in figure 7. The resilient biasing device (601) comprises a unitary body (602) comprising a central portion (85) from which extends a first inwardly curving portion (604) comprising a first free end (606) and a second inwardly curving portion (608)  
20 comprising a second free end (610); wherein the first inwardly curving portion (604) and the second inwardly curving portion (608) are indirectly connected together via an annular member (86) at a connection position (612) set in from the first (606) and second (610) free ends. The central portion (85) is a curved portion located at the top of the resilient biasing device (601).

An eighth embodiment of a resilient biasing device (701) of the invention is illustrated in figure 8. The resilient biasing device (701) comprises a unitary body (702) comprising a central point (703) from which extends a first inwardly curving portion (704) comprising a first free end (706) and a second inwardly curving portion (708) comprising a second free end (710); wherein the first inwardly curving portion (704) and the second inwardly curving portion (708) are directly connected together at a connection position (712) set in from the first (706) and second (710) ends. A further connector (724) is located between the connection position (712) and the free ends (706, 710). The further connector (724) comprises a bracket (88). The bracket (88) is detachably connected to the resilient biasing device (701). This embodiment is advantageous because the bracket (88) may be suitable for connecting the resilient biasing device (701) to an article.

Use of the resilient biasing devices of the invention will now be described in storing elastic energy potential.

15 A first embodiment of a method of storing elastic energy potential according to the third aspect of the invention comprised applying a longitudinal force to the first embodiment of the resilient biasing device (1) of Figure 1 such that the resilient biasing device (1) was compressed. The direction of the force is illustrated by an arrow (30) in figure 9. In alternative embodiments not illustrated, the force could be two forces  
20 applied to the resilient biasing device from opposing longitudinal directions. In alternative embodiments not illustrated, the resilient biasing device could be any one of the second to the eighth embodiments of the resilient biasing device of the invention, described hereinabove.

A second embodiment of a method of storing elastic energy potential according to the third aspect of the invention comprised applying a vertical force to the first embodiment of the resilient biasing device (1) of Figure 1 such that the resilient biasing device (1) was compressed. The direction of the force is illustrated by an arrow (40) in figure 10. In alternative embodiments not illustrated, the force could be two forces applied to the resilient biasing device from opposing vertical directions. In alternative embodiments not illustrated, the resilient biasing device could be any one of the second to the eighth embodiments of the resilient biasing device of the invention, described hereinabove.

10 A third embodiment of a method of storing elastic energy potential according to the third aspect of the invention comprised applying a lateral force to the first embodiment of the resilient biasing device (1) of Figure 1 such that the resilient biasing device (1) was twisted. The direction of the force is illustrated by an arrow (50) in figure 11. In alternative embodiments not illustrated, the force could be two forces applied to the resilient biasing device from opposing lateral directions. In alternative embodiments not illustrated, the resilient biasing device could be any one of the second to the eighth embodiments of the resilient biasing device of the invention, described hereinabove.

A first embodiment of an article (90) according to the second aspect of the invention is illustrated in figure 12. The article (90) is a railway suspension system (92) comprising the fourth embodiment of a resilient biasing device (301). The bearing (74) within the annular connection point (70) of the resilient biasing device (301) is fitted around an axle system (94). This embodiment is advantageous because it creates a suspension system for a railway carriage which is securely connected to the axle system (94).

A second embodiment of an article according to the second aspect of the invention comprises a plurality of resilient biasing devices according to any of the first to eighth embodiment of the resilient biasing device or any combination thereof wherein the article is a vehicle. Each resilient biasing device is located within the  
5 bumper, the wheel suspension, the interior or around the engine.

A third embodiment of an article according to the second aspect of the invention comprises a plurality of resilient biasing devices according to any of the first to eighth embodiment of the resilient biasing device or any combination thereof wherein the article is a building. Each resilient biasing device is located below the building. In  
10 alternative embodiments each resilient biasing device is located on at least one wall of the building.

A fourth embodiment of an article according to the second aspect of the invention comprises a plurality of resilient biasing devices according to any of the first to eighth embodiment of the resilient biasing device or any combination thereof  
15 wherein the article is a robotic device. Each resilient biasing device is located within the robotic device or below, above or to at least one side of the robotic device.

A fifth embodiment of an article according to the second aspect of the invention comprises a plurality of resilient biasing devices according to any of the first to eighth embodiment of the resilient biasing device or any combination thereof wherein the  
20 article is a neonatal cot or incubator. Each resilient biasing device is located below, above or to at least one side of the neonatal cot.

A sixth embodiment of an article according to the second aspect of the invention comprises a plurality of resilient biasing devices according to any of the first to eighth

embodiment of the resilient biasing device or any combination thereof wherein the article is an energy generating or energy storage plant. Each resilient biasing device is located below a vessel containing or transferring water within the plant such that the resilient biasing device is compressed when the amount of water is increased.

5           The following statements apply to any one of the second to the sixth embodiments of the article of the invention. The resilient biasing device can be bolted, welded or glued to the article. The number of bolts can be 1, 2, 3 or more. The welds can be fillet welds, full welds or partial penetration welds. The resilient biasing device can be attached to the article through a fitted (cold or hot fitting) axle or axles from the  
10 side through the whole resilient biasing device or part of the resilient biasing device.

The resilient biasing device can be attached to the article through a joint system to enable rotation of the resilient biasing device. The resilient biasing device can be attached using an axis at the top of the centre point. The attachment can be done by adhesion, bolting or clamping using a bracket.

15

#### Experimental verification of functionality

The following tests were completed with the third embodiment of the resilient biasing device (201) of Figure 3, wherein the height, width and thickness of the resilient biasing device were 64 mm, 20 mm and 3 mm respectively. The resilient biasing  
20 devices was additively manufactured (3D printed) using laser powder bed fusion of Ti<sub>6</sub>Al<sub>4</sub>V.

The resilient biasing device (201) was tested in a testing apparatus (40) as illustrated in figure 13. The resilient biasing device (201) was mounted on an axis (42)

via the aperture (26). A force, illustrated by the arrow (44) was applied to the resilient biasing device (201) in a vertical direction, such that the resilient biasing device (201) was compressed at a quasi-static rate on a 50 kN Shimadzu machine.

The force-displacement relationship was measured during loading and unloading as shown in figure 14. Figure 14 shows that the force-displacement relationship is linear, hence the stiffness of the tested embodiment is a constant value. It also shows that the unloading follows the loading force-displacement behaviour indicating that the elastic energy generated during loading is fully restored after unloading. This test demonstrated that the embodiment has the required functionality of a resilient biasing device.

#### Physics-based analytical and simulation data

An analytical solution was developed to predict the compressive stiffness ( $k$ ) of the embodiment considering the height ( $h$ ), thickness ( $t$ ), width ( $w$ ) and the Young's modulus of the material  $E$ . The relationship is given by:

$$k = \frac{\alpha w t^3 E}{h^3} \quad (1)$$

where  $\alpha$  is a constant for the embodiment constructed with the Fibonacci (golden) spiral which was found to be  $\alpha = \varphi^\varphi = 1.618^{1.618} = 2.178$ . The excellent correlation between the proposed analytical solution and the experimental test are illustrated in figure 15. Figure 15 also shows predicted force versus displacement using a developed physics-based finite element model where the predictions are in a close correlation with

the experimental test. Both the finite element analysis (FEA) and the analytical solution used a Young's modulus of 110 GPa to represent the elastic behaviour of the Ti<sub>6</sub>Al<sub>4</sub>V.

Figure 16 illustrates a graph of simulation data using FEA predictions and analytical data to test the stiffness. The resilient biasing device (201) was formed from Ti<sub>6</sub>Al<sub>4</sub>V and the height and thickness of the resilient biasing device (201) was varied while the width was kept a constant value of 20 mm. The tested heights of the resilient biasing device (201) were 34 mm, 64 mm, 102 mm and 136 mm. The tested thicknesses were between 1 and 12 mm.

Figure 16 show that the stiffness of the resilient biasing device (201) increases as the thickness of the resilient biasing device (201) increases and this trend is consistent as the height of the resilient biasing device (201) is increased. The width was found to linearly increase the stiffness in the FEA, which is in correlation with equation 1. This therefore shows that the resilient biasing device (201) is scalable in size and provides good spring properties due to the thickness and the shape of the resilient biasing device (201), in particular, the connection point (212) and the inwardly curving portions (204, 208).

Further FEA were conducted to identify the maximum displacement applied at the central point (3) in the vertical direction at which the embodiment will reach the elastic limit of the embodiment for different theoretical values of the Young's modulus and the elastic limit. Based on the simulation data, an analytical solution was derived where the maximum displacement ( $\delta_{max}$ ) for a given stress limit ( $\sigma_{lim}$ ) can be given by:

$$\delta_{max} = \frac{h^2 \sigma_{lim}}{2tE} \quad (2)$$

The stress limit can represent the elastic limit to avoid permanent deformations or a fatigue strength to avoid crack initiation and propagation. Figure 17 illustrates a graph of simulation data using FEA predictions and analytical data to test the maximum deformation at a stress limit of 970 MPa representing the elastic limit of 3D printed Ti<sub>6</sub>Al<sub>4</sub>V material. The height and thickness of the resilient biasing device was varied while the width was kept a constant value of 20 mm. The tested heights of the resilient biasing device were 34 mm, 64 mm, 102 mm and 136 mm. The tested thicknesses were between 1 and 12 mm. The results showed correlation between simulation and analytical data indicating that the maximum displacement before permanent deformations for the resilient biasing device can be obtained using the geometrical values and the material properties. Furthermore, the stress limit can represent the fatigue strength of the material so that the resilient biasing device can be designed to endure cyclic loads over time and prevent crack initiation.

The maximum force can be given by  $F_{max} = \delta_{max}k$  at a given stress limit. Substituting the displacement and stiffness by equations 2 and 1, the maximum force can be given in a general form by:

$$F_{max} = \frac{\alpha w t^2 \sigma_{lim}}{2h} \quad (3)$$

Figure 18 shows the maximum force that can be applied to avoid permanent deformations without exceeding the elastic limit of the material. It is advantageous to know the maximum forces for a given stress limit (elastic limit or fatigue strength) of the material and geometrical parameters of the resilient biasing device to enable reliable design.

Figures 16, 17 and 18 illustrate the capability of the resilient biasing device that it can be designed to deliver a required application performance (stiffness, maximum displacement and maximum force) by changing the geometric parameters (width, height and thickness) and material properties.

5           Figure 19 illustrates the predicted force-displacement relationship using FEA for the embodiment with height of 64 mm, width of 20 mm and thickness of 3 mm at three different directions (vertical consisting of tension and compression, longitudinal and lateral). The force-displacement relationship is obtained just before reaching the elastic limit for the Ti<sub>6</sub>Al<sub>4</sub>V resilient biasing device of 970 MPa assuming that a rigid  
10 article is fixed to the central portion and the resilience biasing device is rigidly held at the connection position.

Figure 19 illustrates the capability of multi-axial stiffness of the device. The stiffness in each direction can be further modified by changing the geometrical parameters, which is an advantage to deliver design performance.

15           The above embodiments are described by way of example only. Many variations are possible without departing from the scope of the invention as defined in the appended claims.

CLAIMS

1. A resilient biasing device comprising;  
  
a unitary body comprising a central portion from which extends a first  
5 inwardly curving portion comprising a first end and a second inwardly curving  
portion comprising a second end;  
  
wherein the first inwardly curving portion and the second inwardly curving  
portion are directly or indirectly connected together or contact each other at a  
connection position set in from the first and second ends.
- 10 2. A resilient biasing device according to claim 1 wherein the first inwardly  
curving portion comprises a spiral and the second inwardly curving portion  
comprises a second spiral.
3. A resilient biasing device according to any claim 1 or claim 2 wherein the first  
15 inwardly curving portion is curved in a clockwise direction and the second  
inwardly curving portion is curved in an anti-clockwise direction.
4. A resilient biasing device according to any preceding claim wherein the first  
inwardly curving portion and the second inwardly curving portion are  
symmetrical.
5. A resilient biasing device according to any preceding claim wherein the body  
20 comprises a wire or a tube.
6. A resilient biasing device according to any one of claims 1 to 4 wherein the  
body comprises a strip comprising a front face and a back face.

7. A resilient biasing device according to claim 6 wherein the strip comprises a quadrilateral cross-section.
8. A resilient biasing device according to claim 6 or 7 wherein the front face of the first inwardly curving portion is fixedly connected to the opposing front  
5 face of the second inwardly curving portion at the connection position set in from the ends of each curving portion.
9. A resilient biasing device according to any preceding claim wherein the first end is a first free end and the second end is a second free end.
10. A resilient biasing device according to any one of claims 1 to 8 wherein the  
10 first end and the second end are connected.
11. A resilient biasing device according to any preceding claim wherein the first inwardly curving portion and the second inwardly curving portion are planar parallel.
12. A resilient biasing device according to any preceding claim wherein the first  
15 and second inwardly curving portions are integrally connected at the connection position.
13. A resilient biasing device according to any preceding claim comprising a further connector, in addition to the connection position, wherein the further connector is located between the connection position and the first and second  
20 ends.
14. A resilient biasing device according to claim 12 or claim 13 wherein the device is connected to a piezoelectric device.

15. A resilient biasing device according to any preceding claim comprising a sensor located between the connection position and the first and second ends or located at any point on the unitary body.
16. An article comprising at least one resilient biasing device according to any one  
5 of claims 1 to 15.
17. An article according to claim 16 wherein the at least one resilient biasing device is located beneath, above or within the article.
18. An article according to claim 16 or 17 comprising two or more resilient biasing devices.
- 10 19. A method of storing elastic potential energy comprising applying a force to a resilient biasing device according to any one of claims 1 to 15 and compressing, stretching or twisting the resilient biasing device.
20. A method according to claim 19 comprising applying the force in at least one of a vertical direction, a lateral direction and a longitudinal direction, or any  
15 combination thereof.
21. A method according to claim 19 or 20 comprising compressing the resilient biasing device.
22. A method according to claim 21 comprising compressing the resilient biasing device along a single axis.
- 20 23. A method according to claim 21 comprising compressing the resilient biasing device along multiple axes.

24. A method according to claim 19 or 20 comprising stretching the resilient biasing device.
25. A method according to claim 24 comprising stretching the resilient biasing device along a single axis.
- 5 26. A method according to claim 24 comprising stretching the resilient biasing device along multiple axes.
27. A method according to claim 19 or 20 comprising twisting the resilient biasing device.

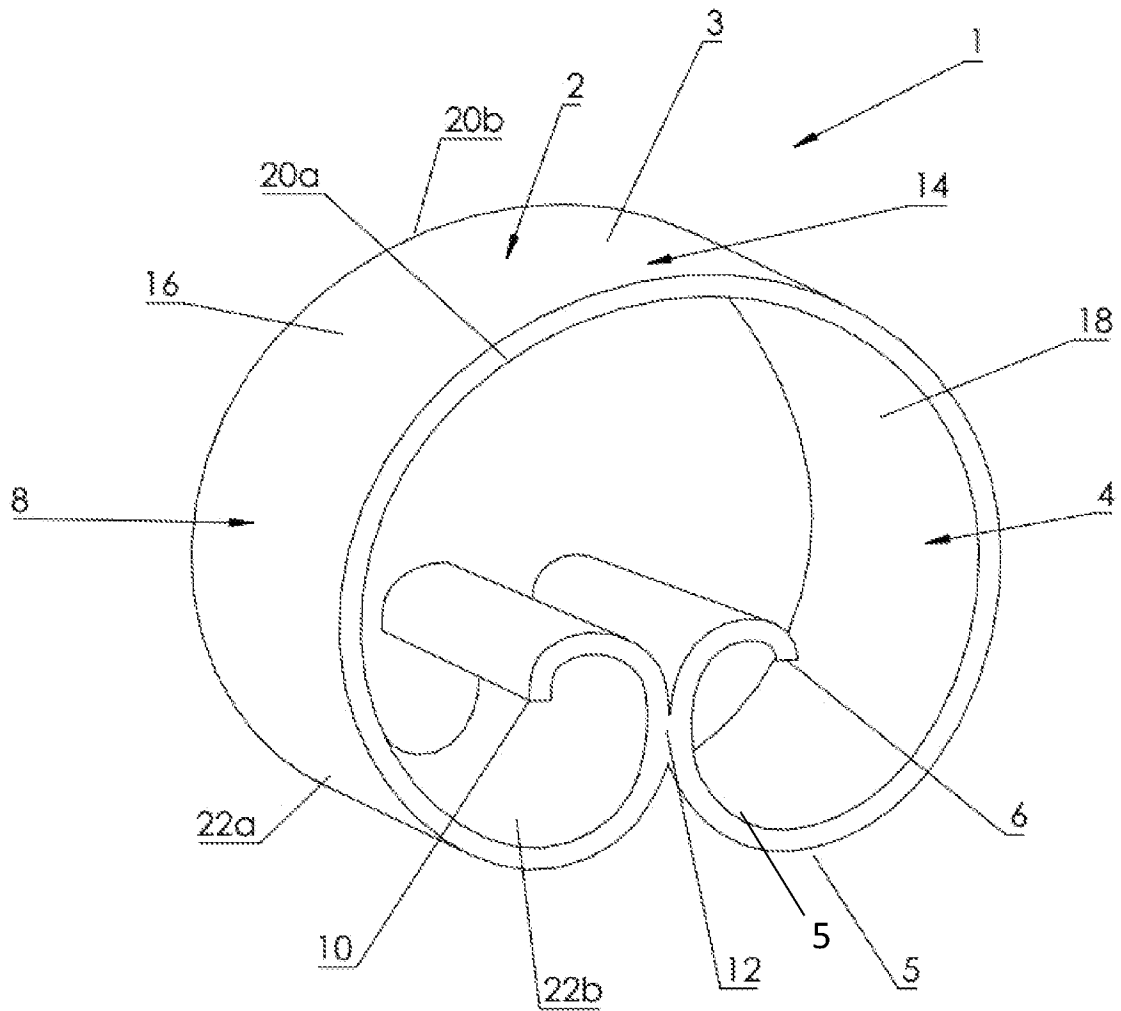

Fig. 1

2/16

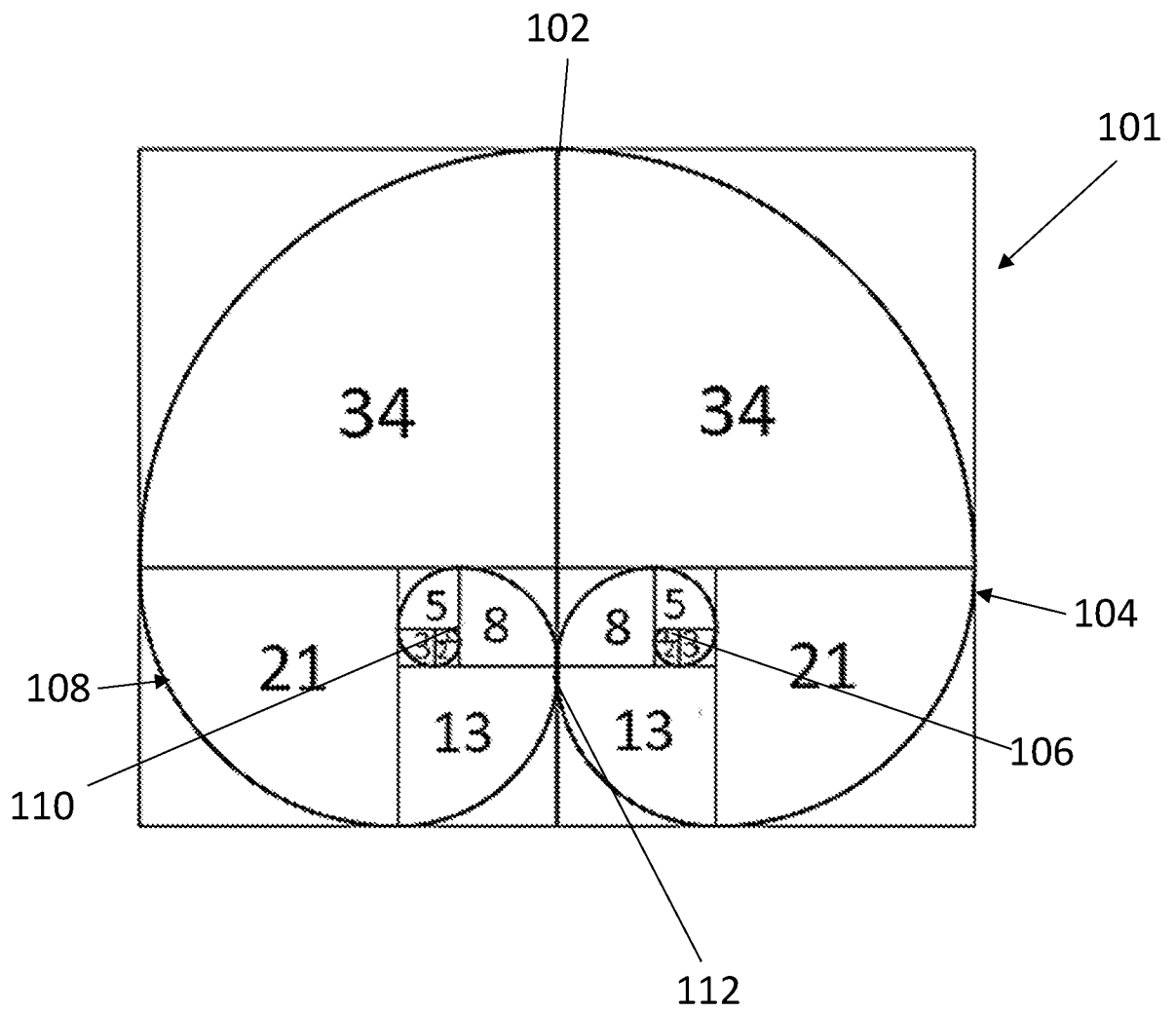

Fig. 2

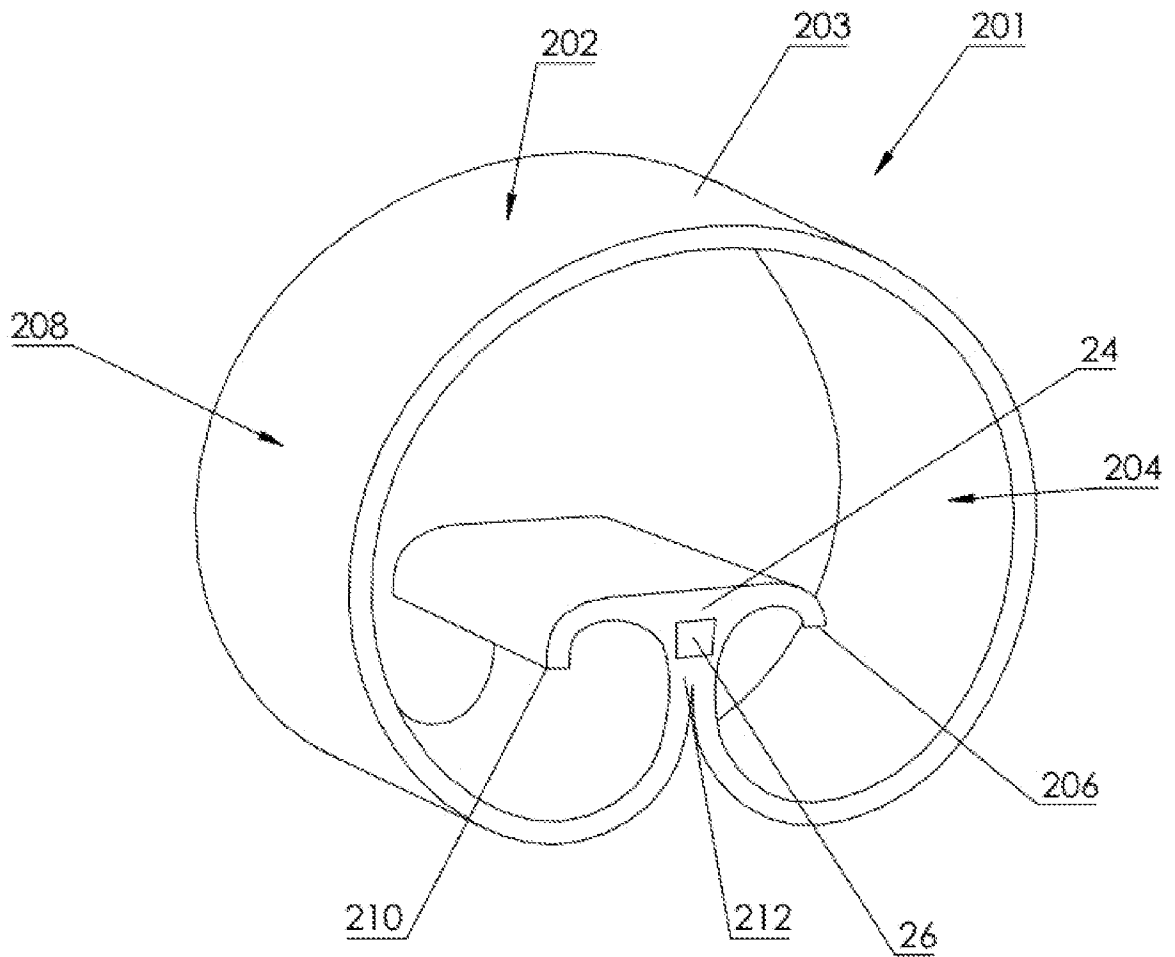

Fig. 3

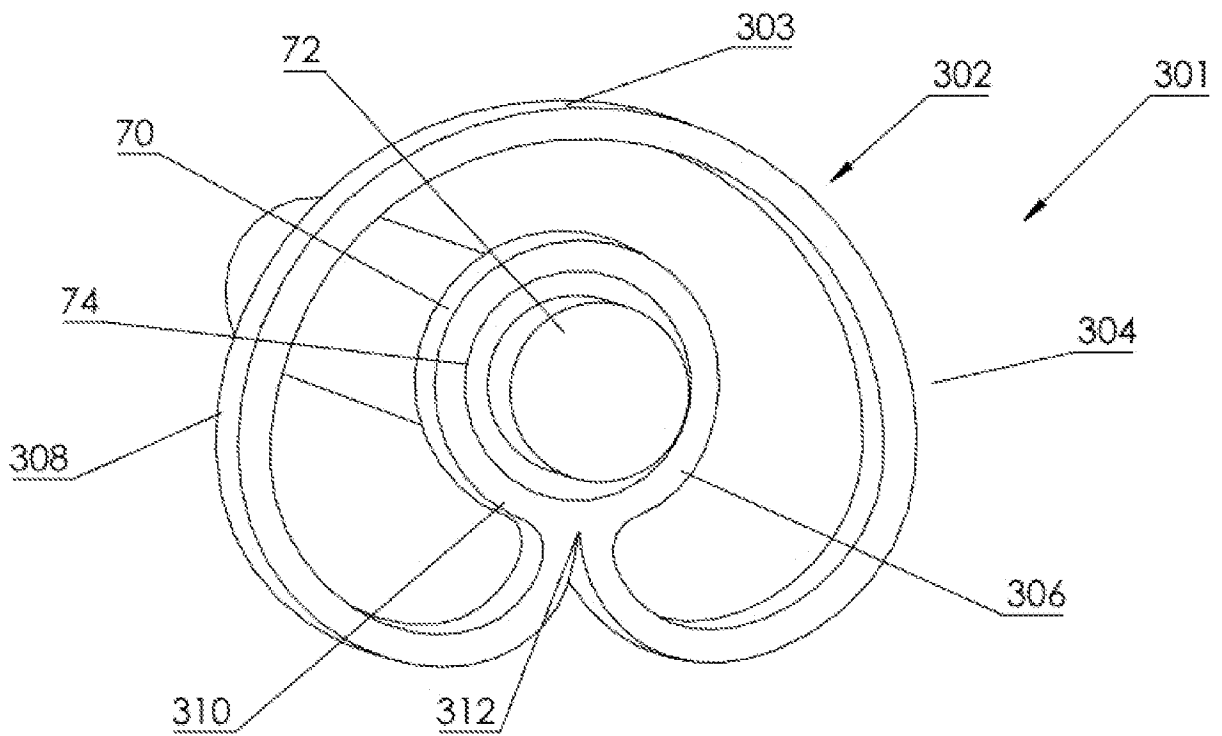

Fig. 4

5/16

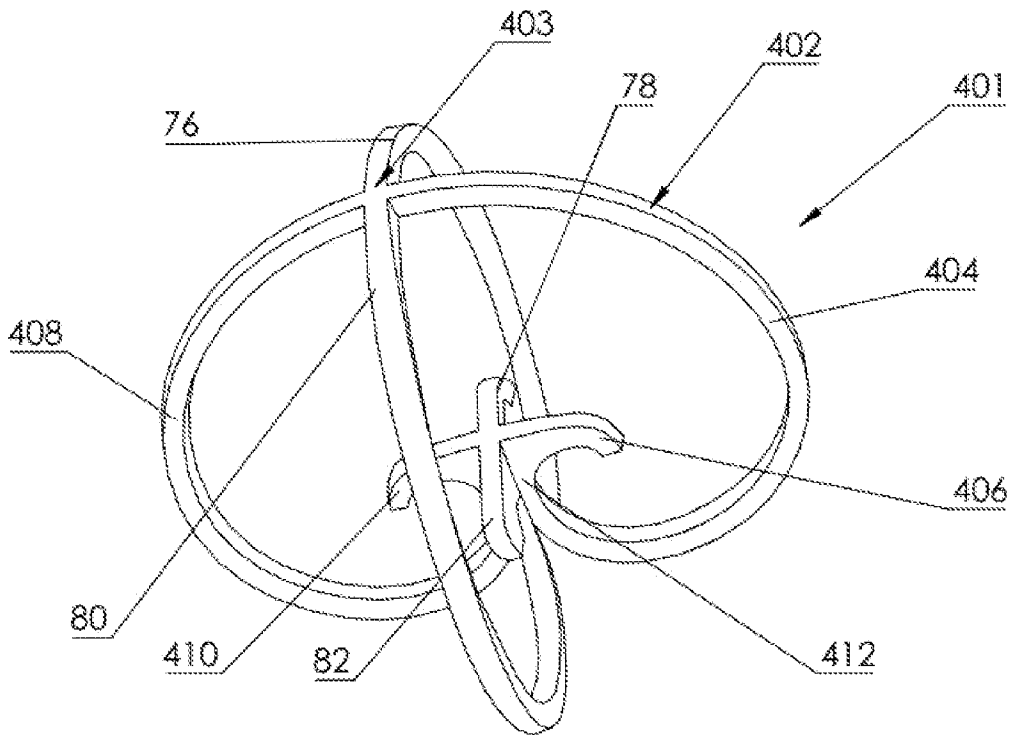

Fig. 5

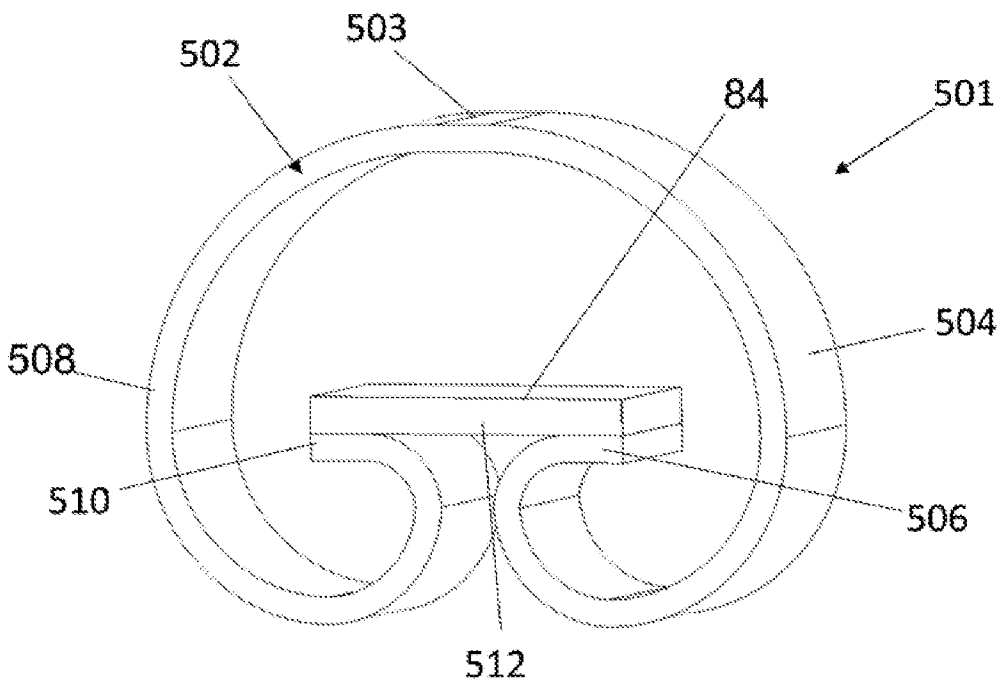

Fig. 6

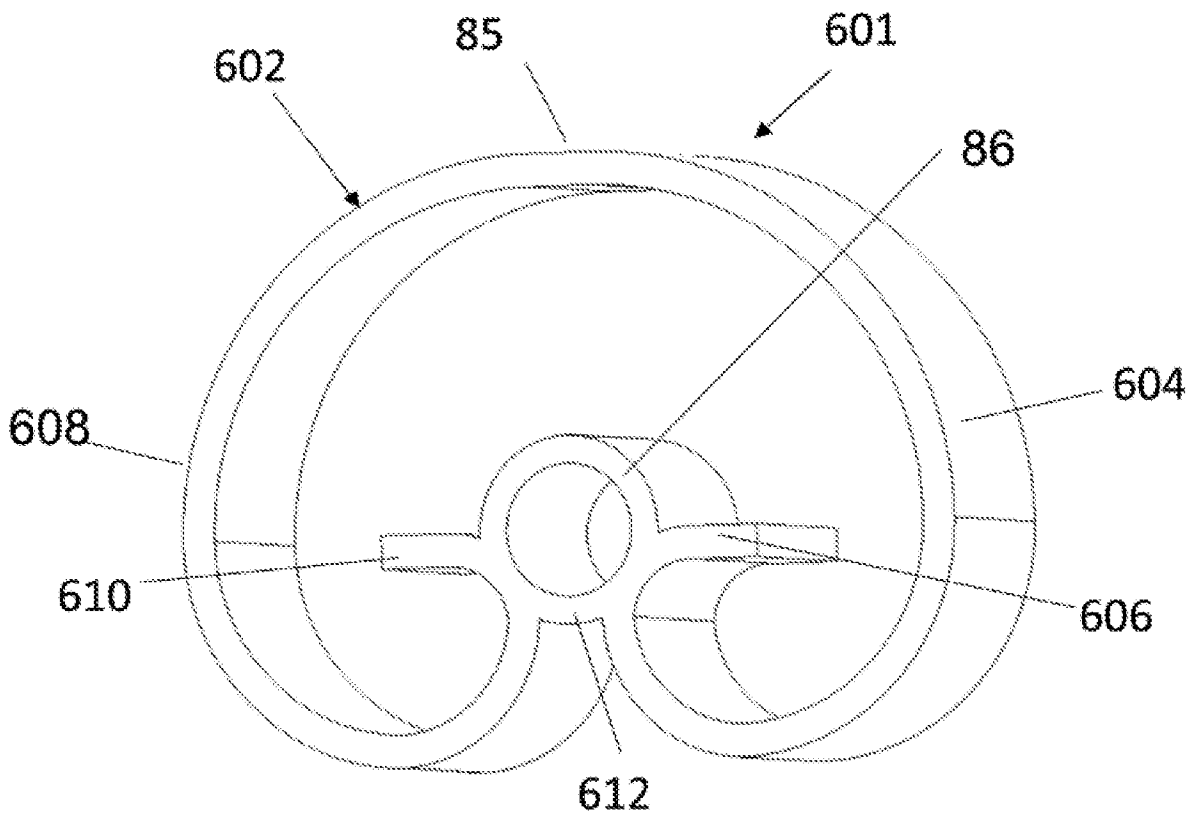

Fig. 7

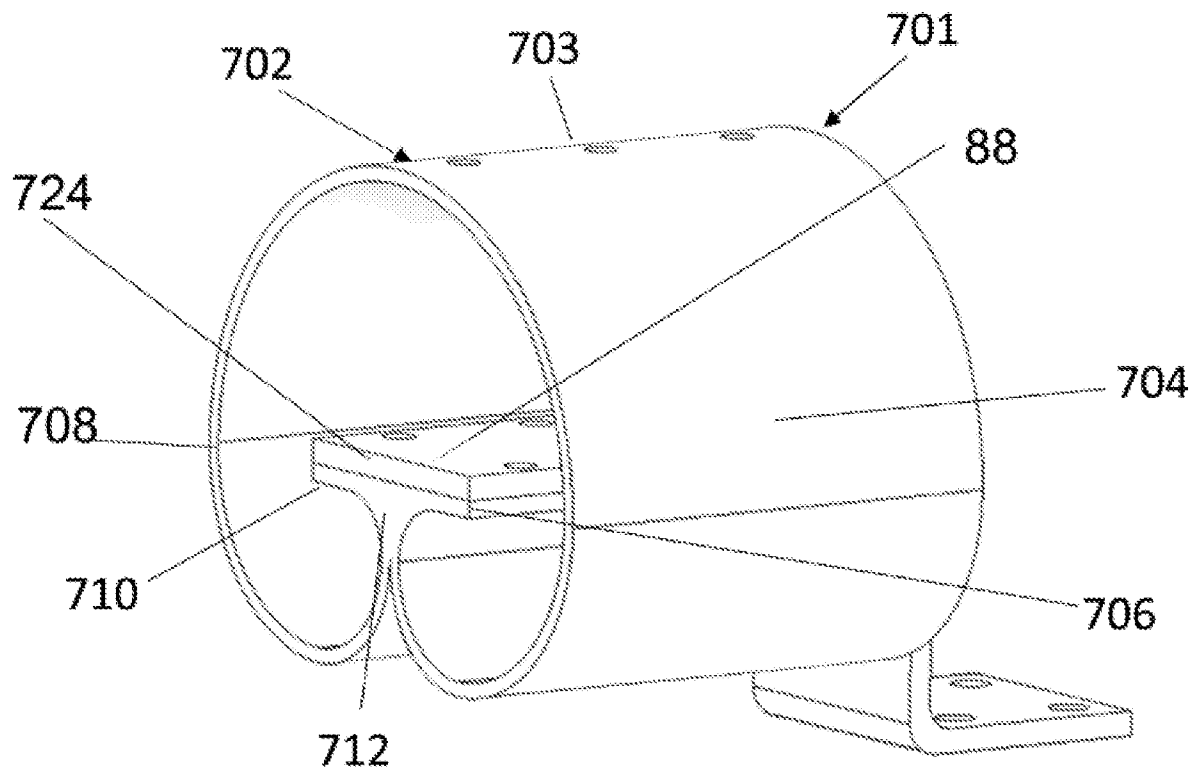

Fig. 8

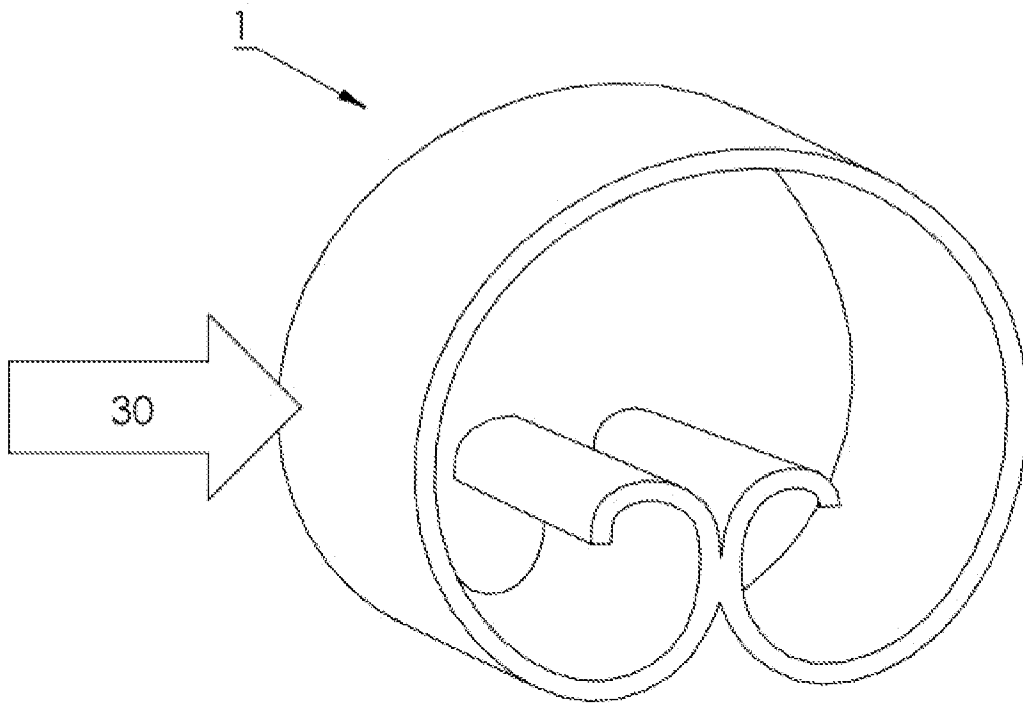

Fig. 9

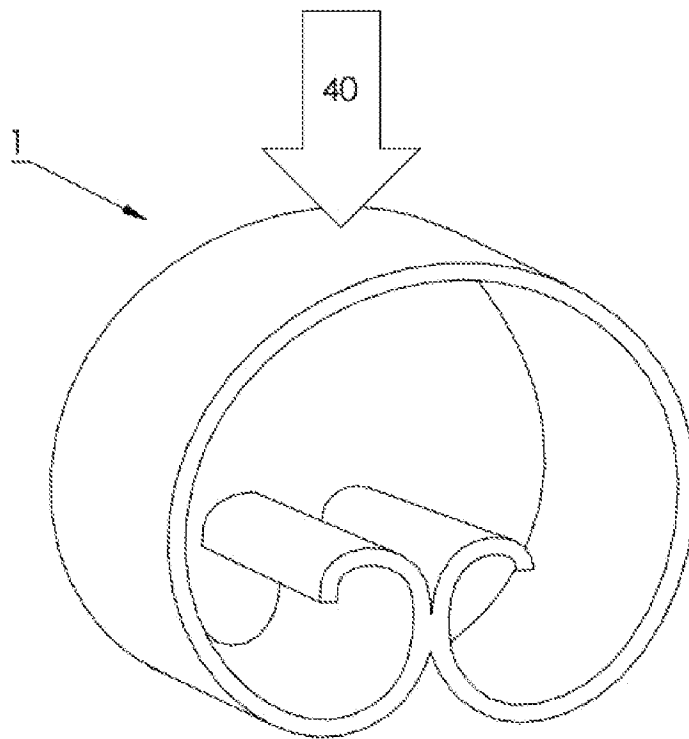

Fig. 10

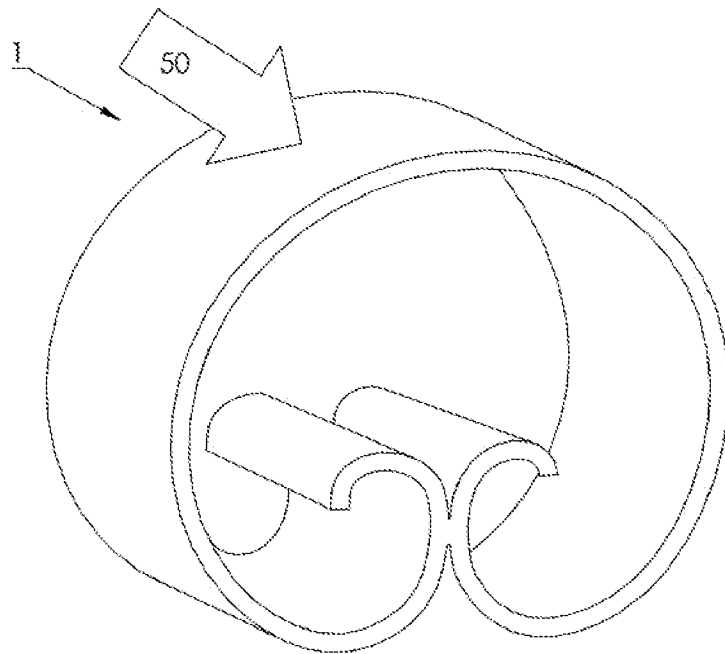

Fig. 11

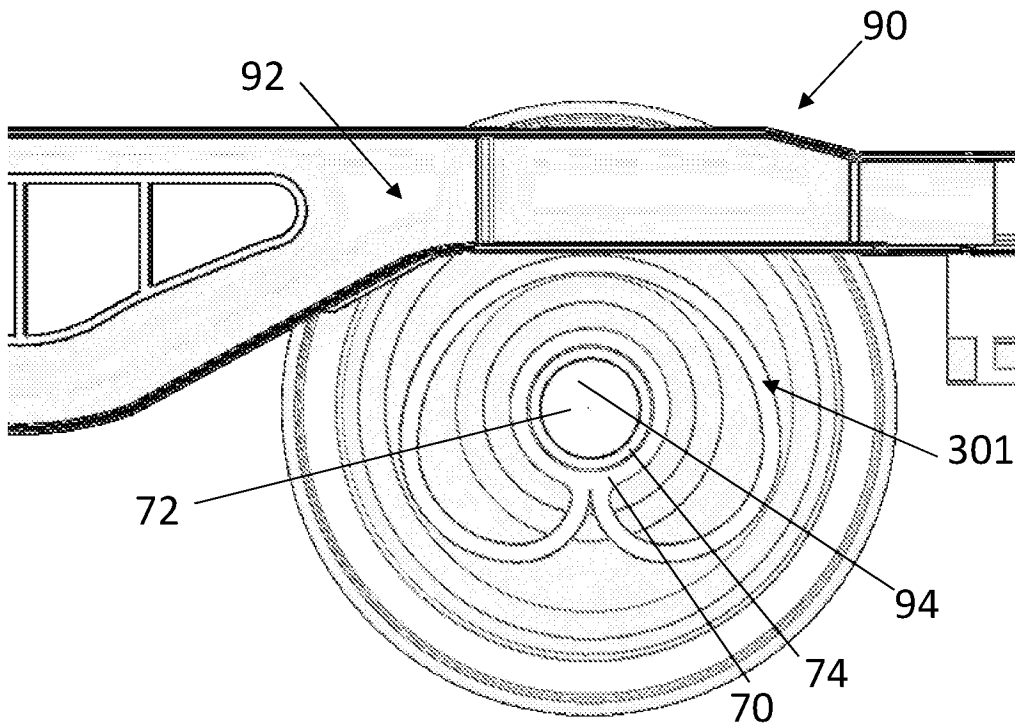

Fig. 12

10/16

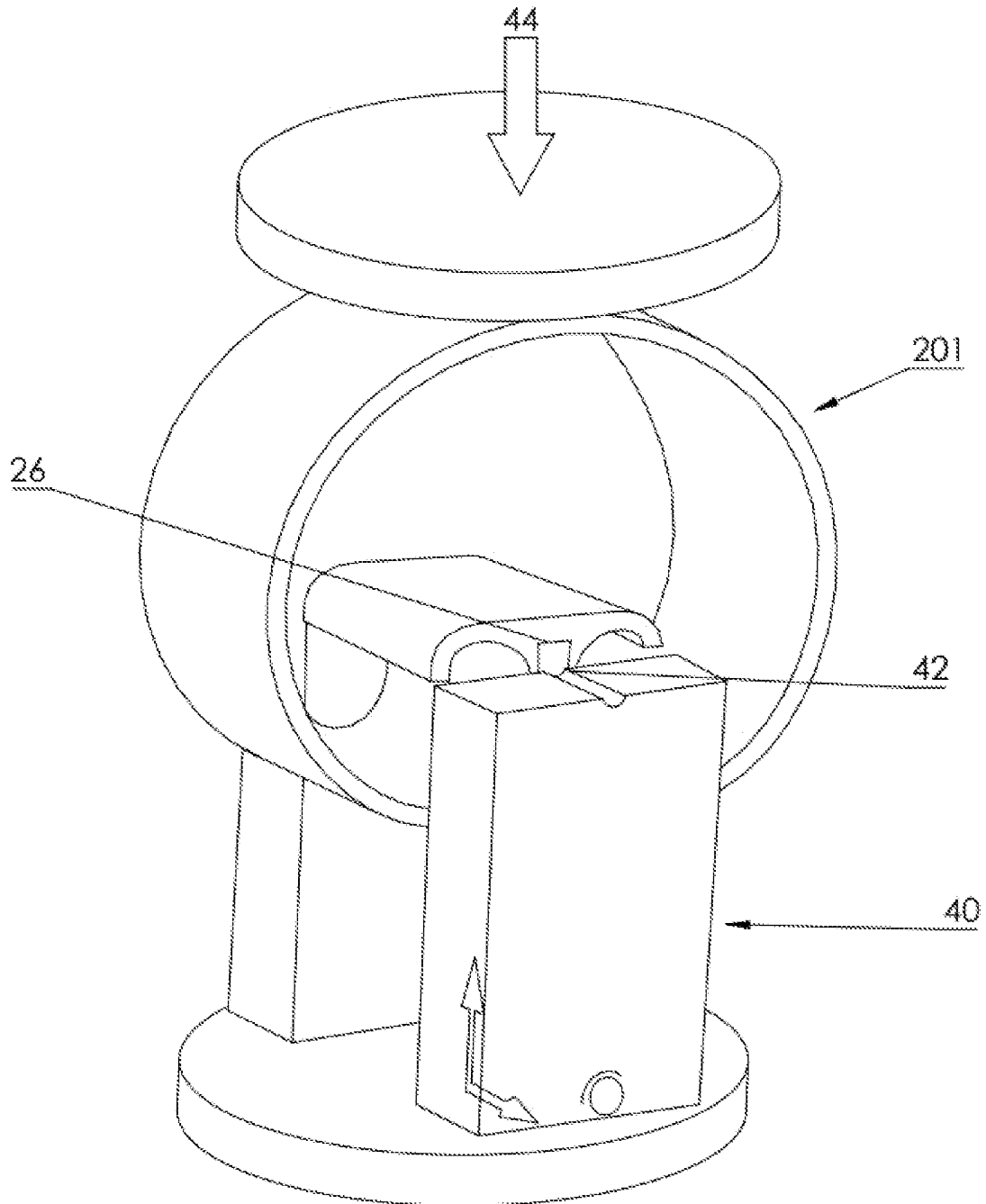
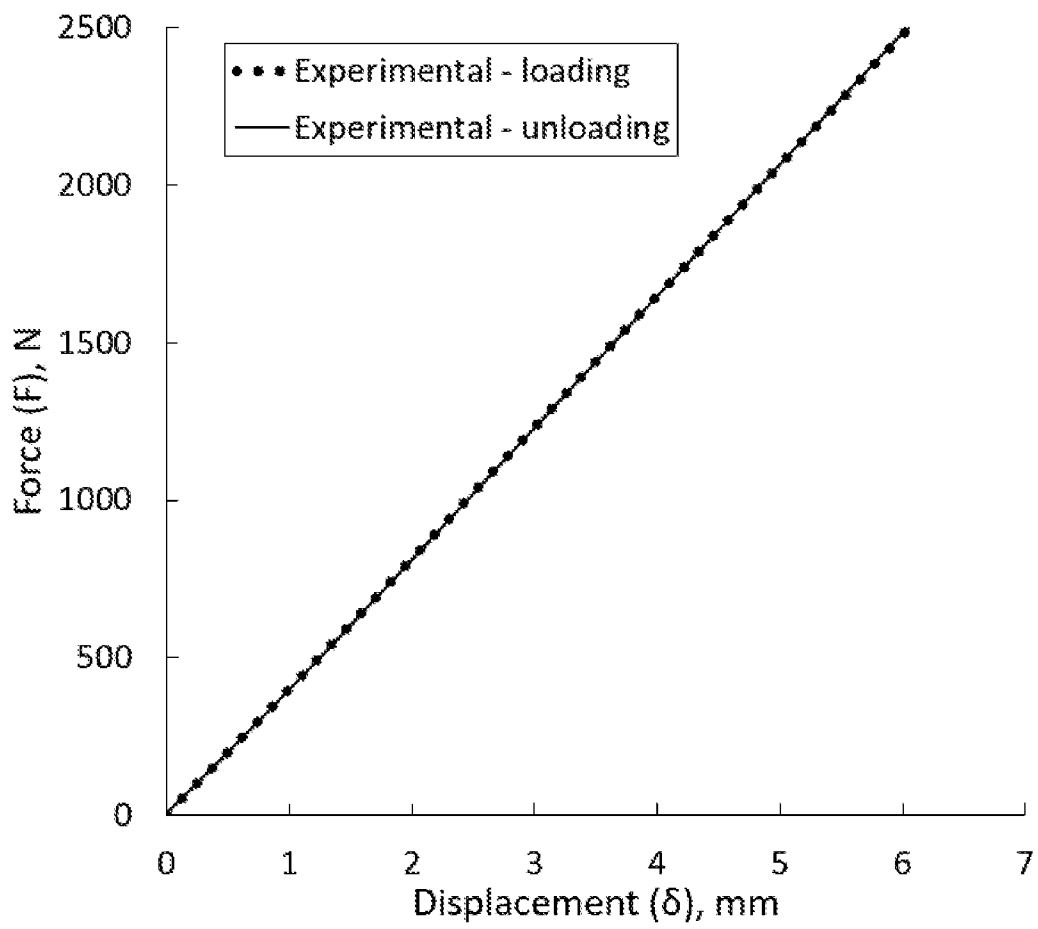
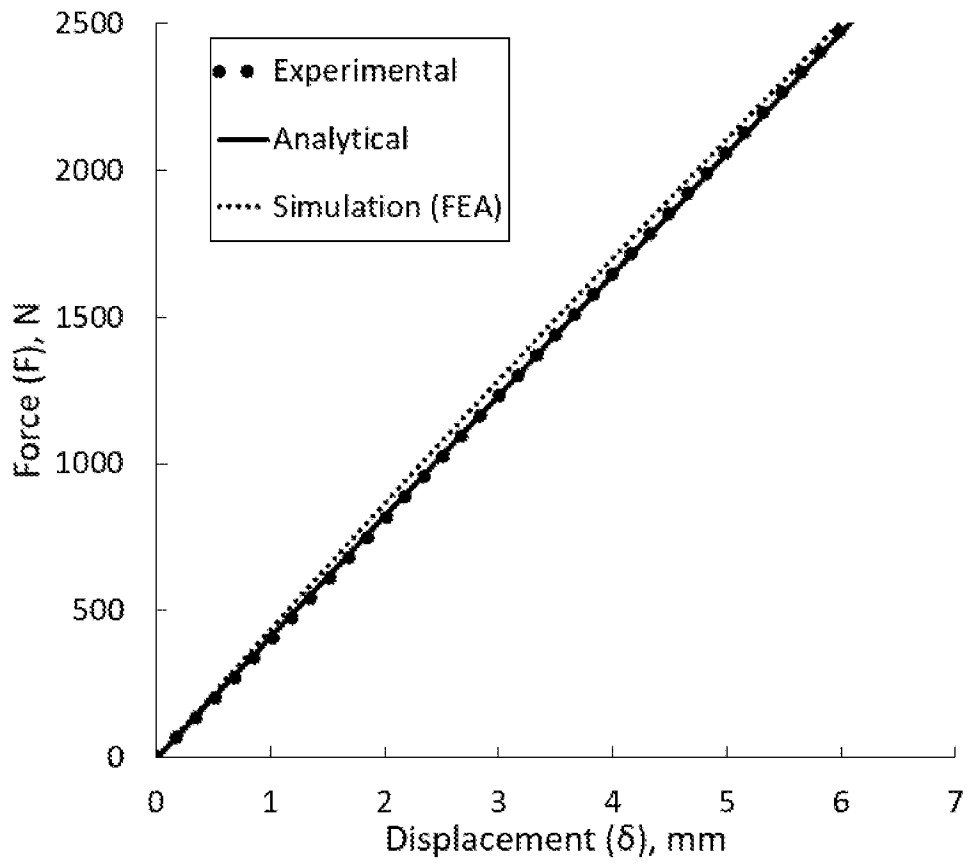

Fig. 13



**Fig. 14**



**Fig. 15**

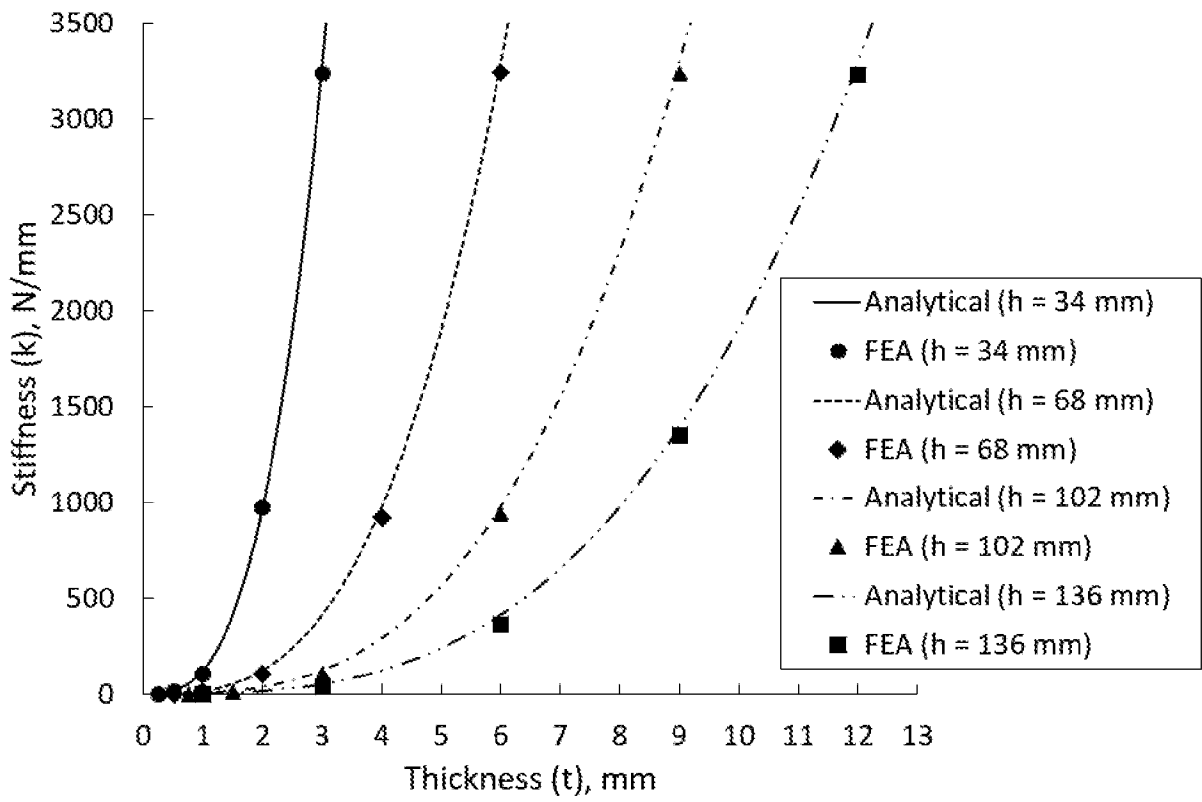

Fig. 16

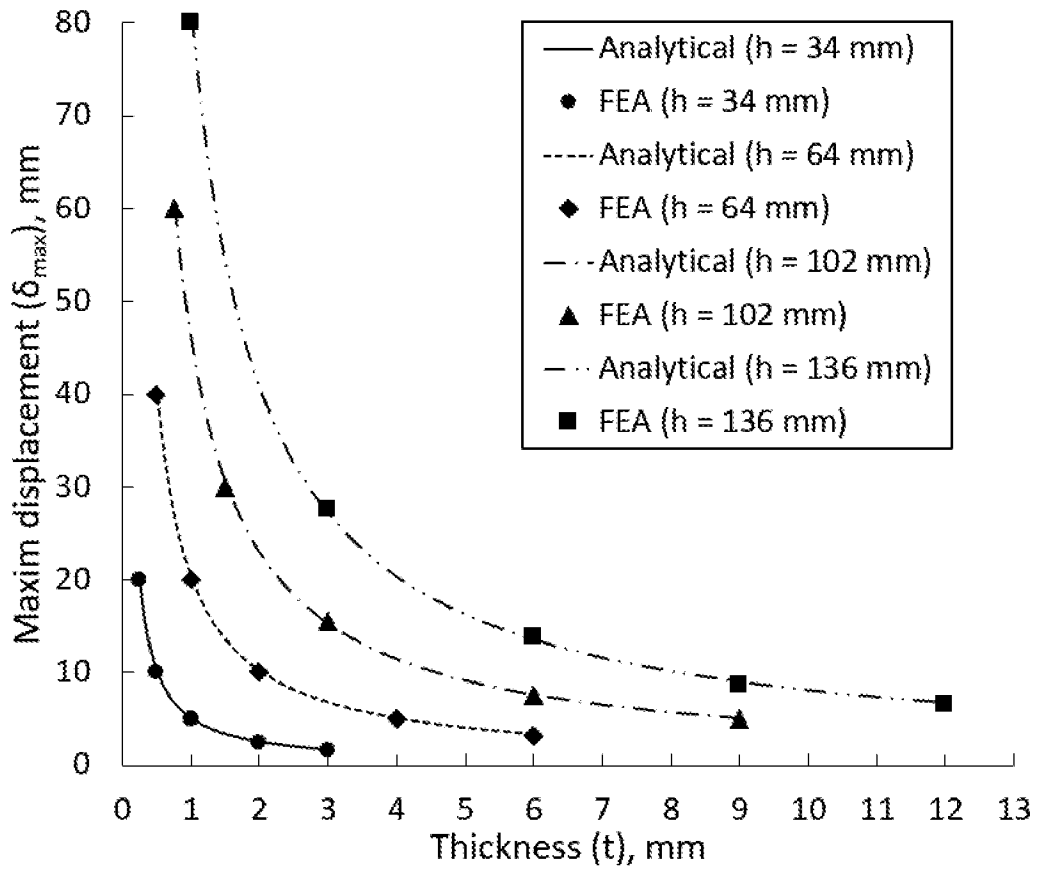

Fig. 17

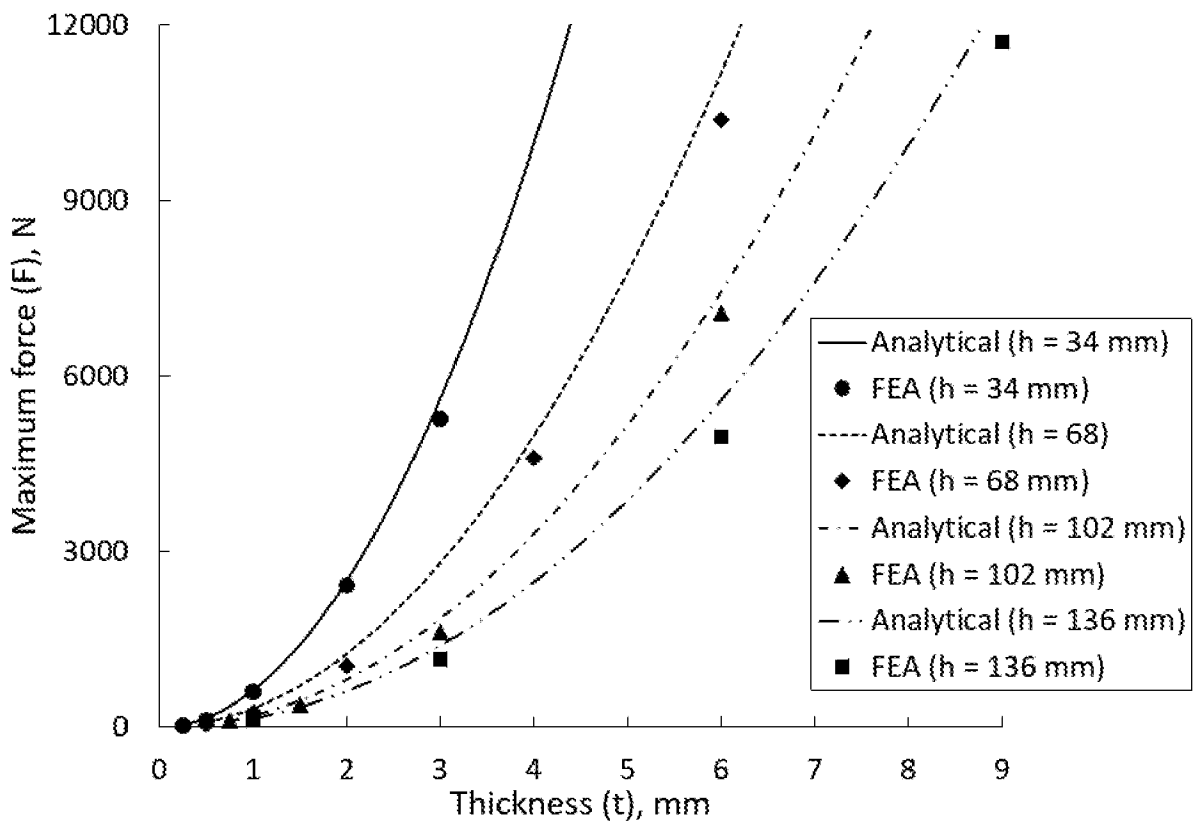

Fig. 18

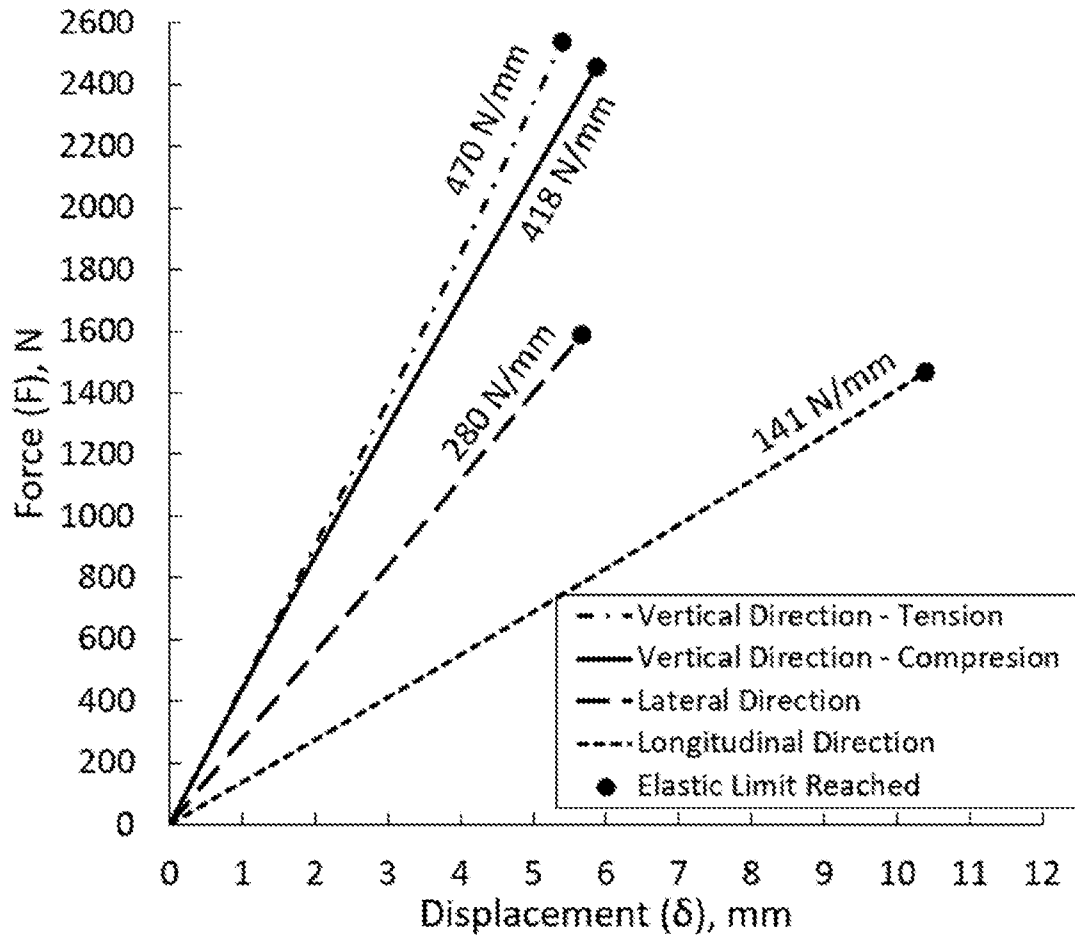

Fig. 19

# INTERNATIONAL SEARCH REPORT

International application No  
PCT/GB2024/051963

**A. CLASSIFICATION OF SUBJECT MATTER**  
INV. F16F1/18 F16F1/02  
ADD.

According to International Patent Classification (IPC) or to both national classification and IPC

**B. FIELDS SEARCHED**

Minimum documentation searched (classification system followed by classification symbols)  
**F16F**

Documentation searched other than minimum documentation to the extent that such documents are included in the fields searched

Electronic data base consulted during the international search (name of data base and, where practicable, search terms used)

**EPO-Internal**

**C. DOCUMENTS CONSIDERED TO BE RELEVANT**

Category*	Citation of document, with indication, where appropriate, of the relevant passages	Relevant to claim No.
X	US 8 734 020 B2 (ITO HIROYOSHI [JP]; TAKADA SEIICHI [JP]; NTN TOYO BEARING CO LTD [JP]) 27 May 2014 (2014-05-27)	1-11,16, 17, 19-22, 24,25
A	column 15, line 30 - column 16, line 18; figure 9	12-15, 18,23, 26,27
-----		
X	EP 4 187 194 A1 (HOESSL BERNHARD [AT]) 31 May 2023 (2023-05-31)	1-7, 9-22,24, 25
A	the whole document	8,23,26, 27
-----		
X	CN 102 938 512 A (SHENZHEN SUNWAY COMM CO LTD) 20 February 2013 (2013-02-20)	1-11, 16-27
A	abstract; figures	12-15
-----		
- / - -		

Further documents are listed in the continuation of Box C.

See patent family annex.

\* Special categories of cited documents :

"A" document defining the general state of the art which is not considered to be of particular relevance

"E" earlier application or patent but published on or after the international filing date

"L" document which may throw doubts on priority claim(s) or which is cited to establish the publication date of another citation or other special reason (as specified)

"O" document referring to an oral disclosure, use, exhibition or other means

"P" document published prior to the international filing date but later than the priority date claimed

"T" later document published after the international filing date or priority date and not in conflict with the application but cited to understand the principle or theory underlying the invention

"X" document of particular relevance; the claimed invention cannot be considered novel or cannot be considered to involve an inventive step when the document is taken alone

"Y" document of particular relevance; the claimed invention cannot be considered to involve an inventive step when the document is combined with one or more other such documents, such combination being obvious to a person skilled in the art

"&" document member of the same patent family

Date of the actual completion of the international search

**22 October 2024**

Date of mailing of the international search report

**08/11/2024**

Name and mailing address of the ISA/  
European Patent Office, P.B. 5818 Patentlaan 2  
NL - 2280 HV Rijswijk  
Tel. (+31-70) 340-2040.  
Fax: (+31-70) 340-3016

Authorized officer:

**Kramer, Pieter Jan**

# INTERNATIONAL SEARCH REPORT

International application No

PCT/GB2024/051963

**C(Continuation). DOCUMENTS CONSIDERED TO BE RELEVANT**

Category*	Citation of document, with indication, where appropriate, of the relevant passages	Relevant to claim No.
X	US 57312 A (GREENWALT, A.B.) 21 August 1866 (1866-08-21) the whole document -----	1-11, 16-27
X	US 2021/156451 A1 (SUVANTO SAMUEL [FI]) 27 May 2021 (2021-05-27)	1-3,5-7, 9-11, 16-22
A	the whole document -----	4,8, 12-15

# INTERNATIONAL SEARCH REPORT

Information on patent family members

International application No

PCT/GB2024/051963

Patent document cited in search report	Publication date	Patent family member(s)	Publication date
US 8734020	B2	27-05-2014	
		CN 102597558 A	18-07-2012
		EP 2492529 A1	29-08-2012
		JP 5451544 B2	26-03-2014
		JP 2011232319 A	17-11-2011
		US 2012201486 A1	09-08-2012
		WO 2011049020 A1	28-04-2011
-----			
EP 4187194	A1	31-05-2023	
		AT 525707 A1	15-06-2023
		EP 4187194 A1	31-05-2023
-----			
CN 102938512	A	20-02-2013	
		CN 102938512 A	20-02-2013
		KR 20140055895 A	09-05-2014
-----			
US 57312	A	21-08-1866	NONE
-----			
US 2021156451	A1	27-05-2021	
		DE 202020003792 U1	29-09-2020
		EP 3825571 A1	26-05-2021
		US 2021156451 A1	27-05-2021
-----			