



US 20080089006A1

(19) **United States**

(12) **Patent Application Publication**
Zhong et al.

(10) **Pub. No.: US 2008/0089006 A1**

(43) **Pub. Date: Apr. 17, 2008**

(54) **ELECTRODE FOR ENERGY STORAGE DEVICE**

Publication Classification

(75) Inventors: **Linda Zhong**, San Diego, CA (US);
Xiaomei Xi, Carlsbad, CA (US)

(51) **Int. Cl.**
H01G 4/005 (2006.01)
H01M 4/04 (2006.01)
(52) **U.S. Cl.** **361/303**; 29/874; 429/209

Correspondence Address:
MAXWELL TECHNOLOGIES, INC.
9244 BALBOA AVENUE
SAN DIEGO, CA 92123 (US)

(57) **ABSTRACT**

(73) Assignee: **MAXWELL TECHNOLOGIES, INC.**,
San Diego, CA (US)

An energy storage device electrode product is provided. The product comprises: at least one current collector and at least one electrode film disposed adjacent to the at least one current collector. The at least one current collector comprises a plurality of voids extending through a thickness of the current collector, wherein the plurality of voids allow electrolyte to flow through the thickness of the current collector. The plurality of voids extending through the current collector is formed without reducing a surface area of a conductive material of the current collector disposed adjacent to the electrode by more than about fifty percent. A method of producing an electrode product and a double layer capacitor product are also disclosed.

(21) Appl. No.: **11/874,188**

(22) Filed: **Oct. 17, 2007**

Related U.S. Application Data

(60) Provisional application No. 60/852,459, filed on Oct. 17, 2006.

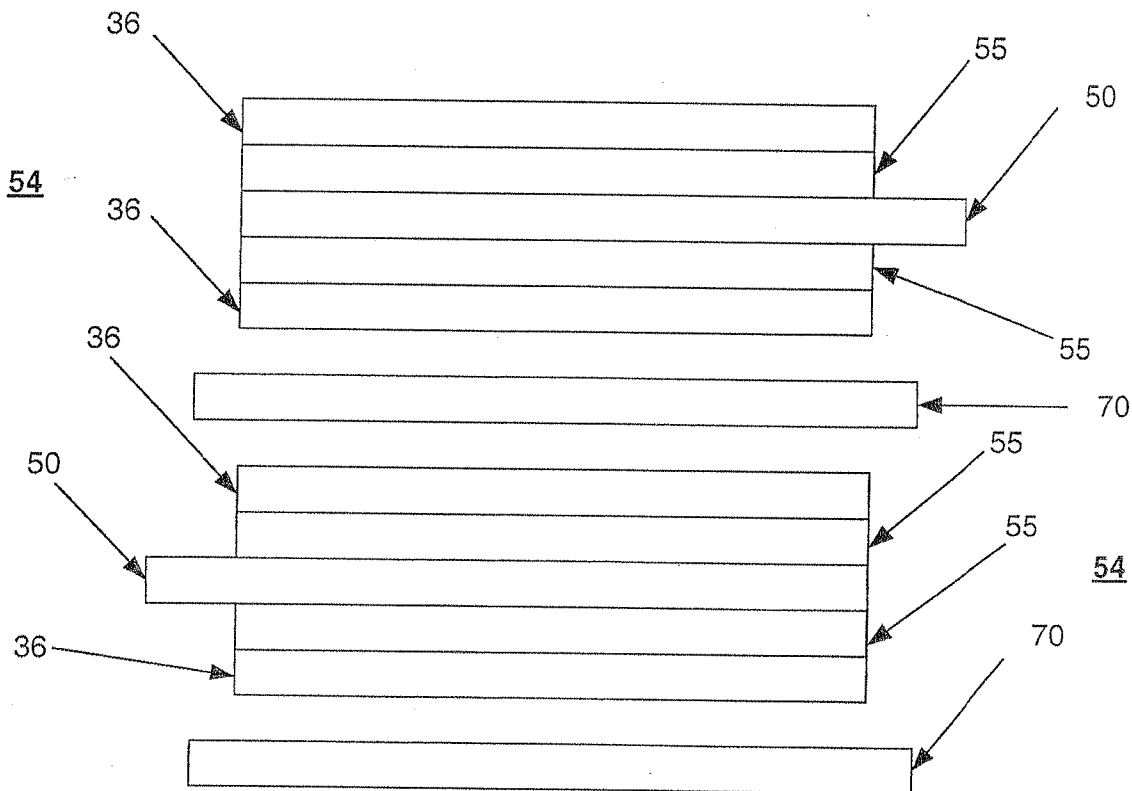

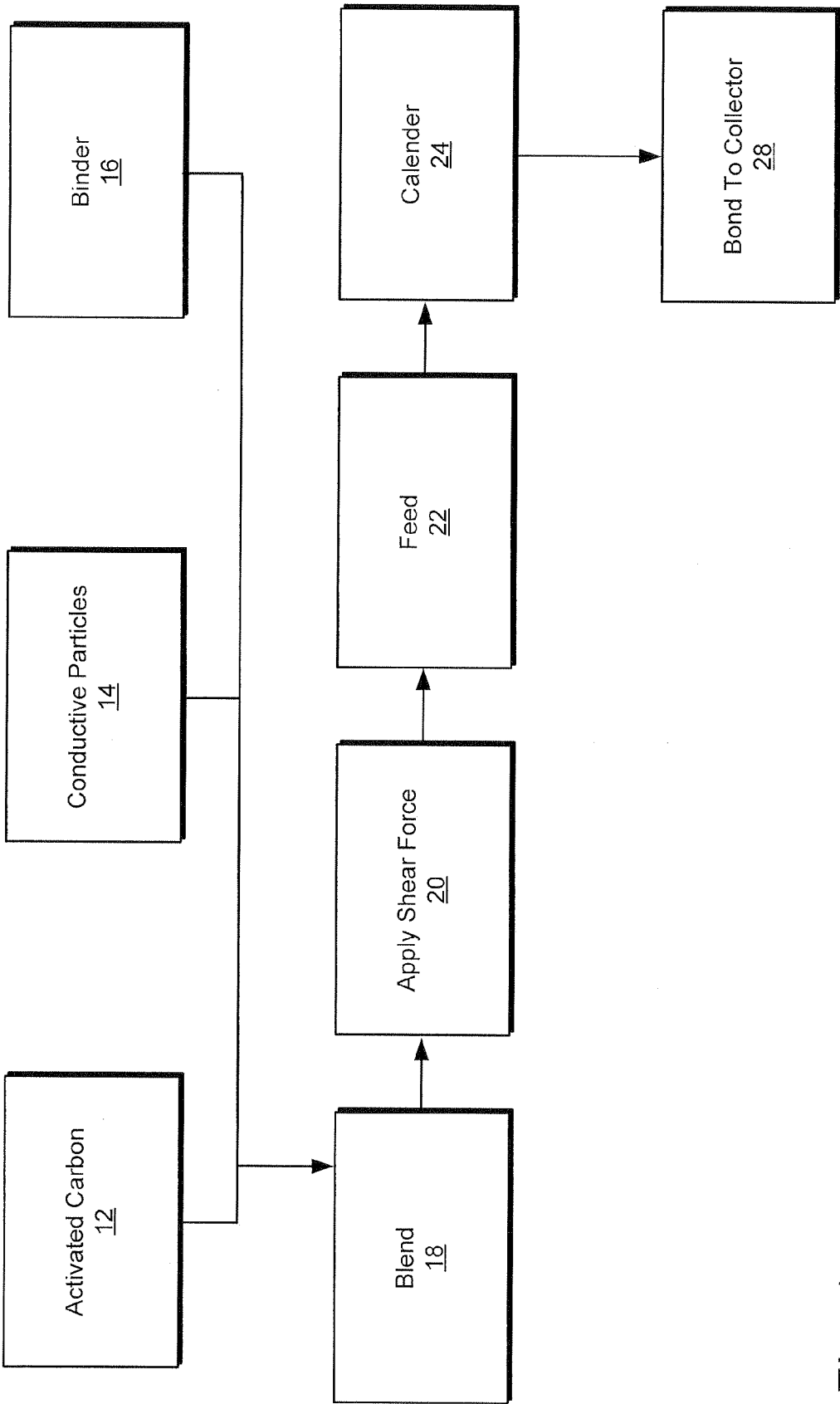

Fig. 1

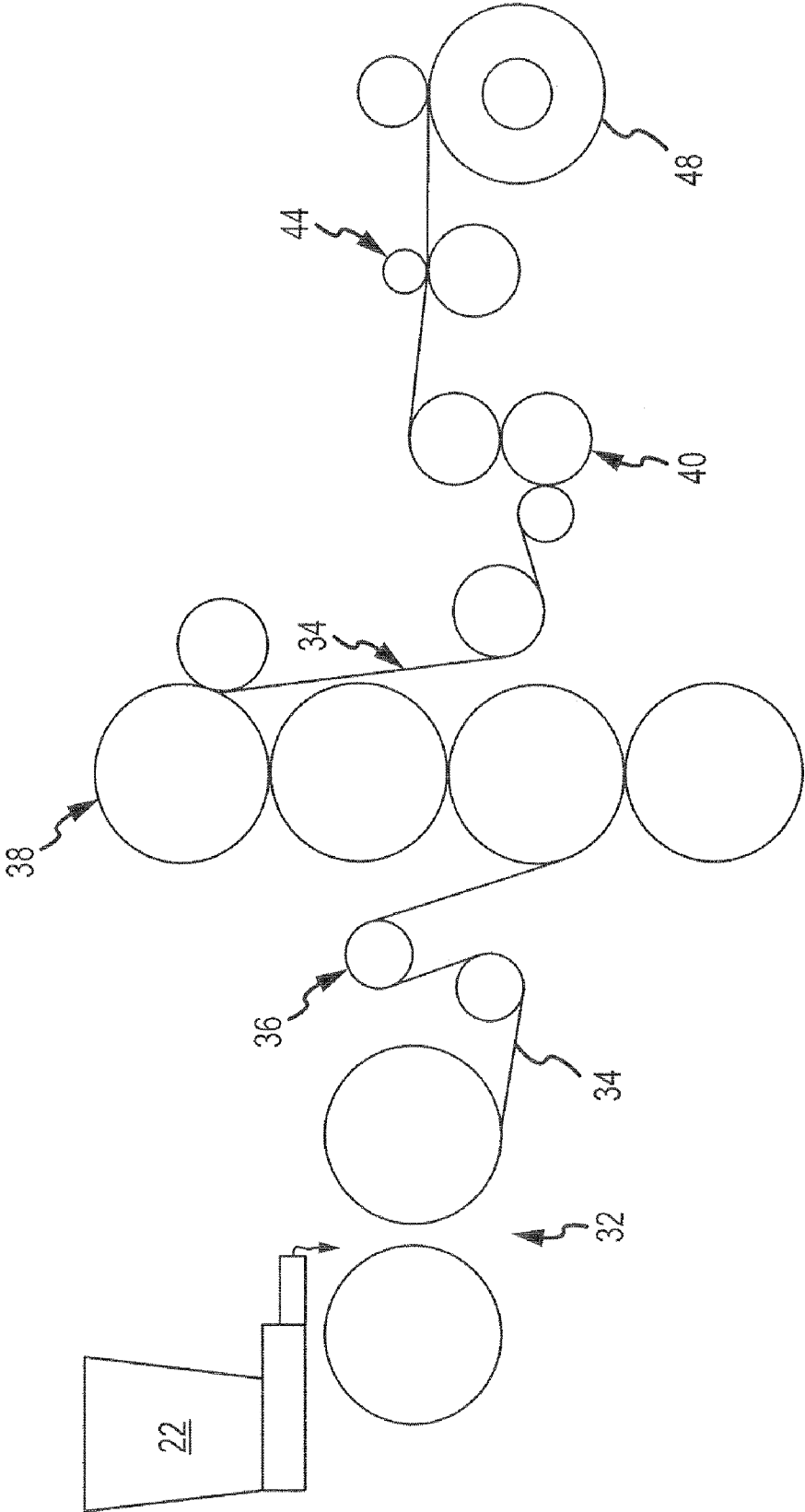

FIG.2

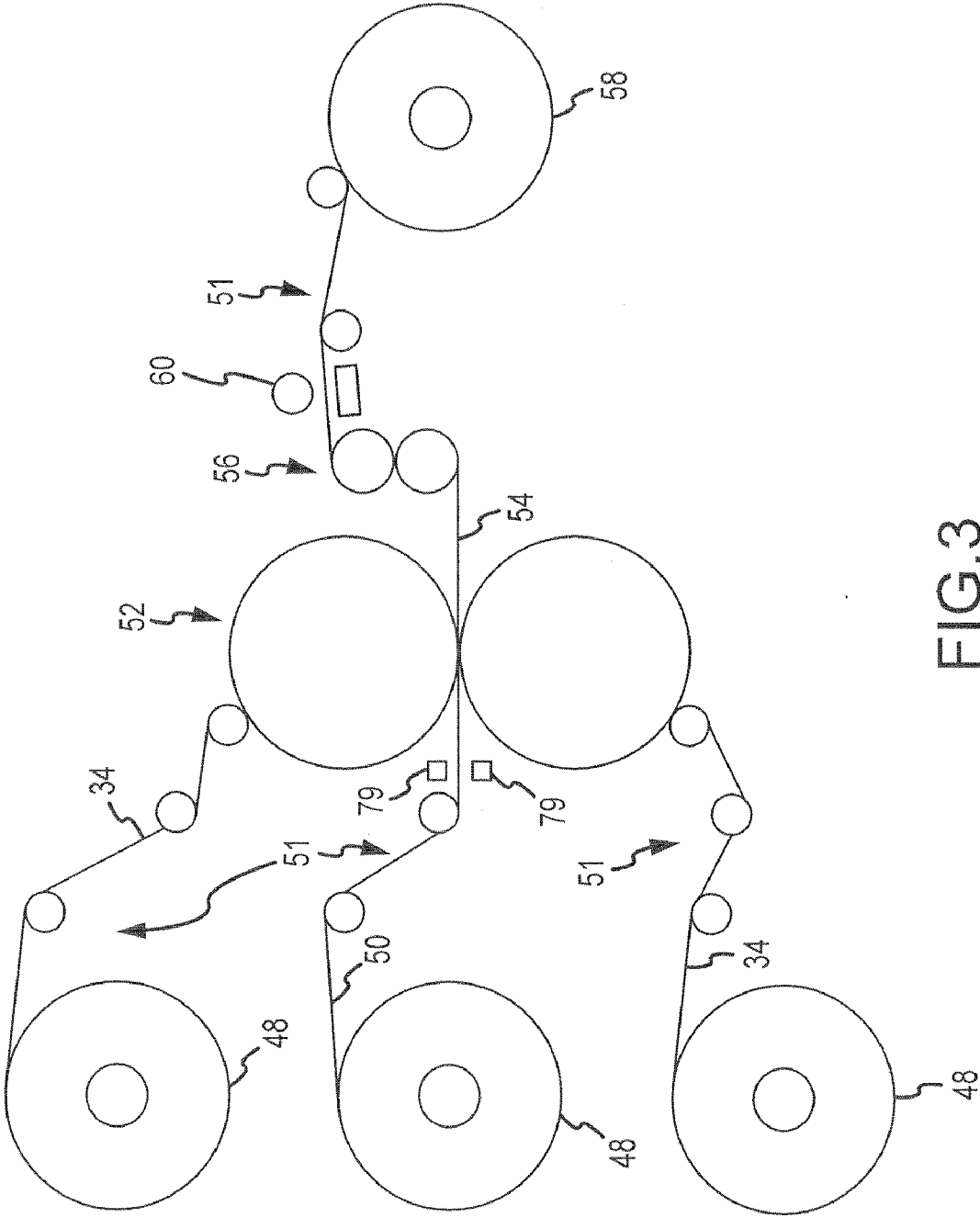

FIG.3

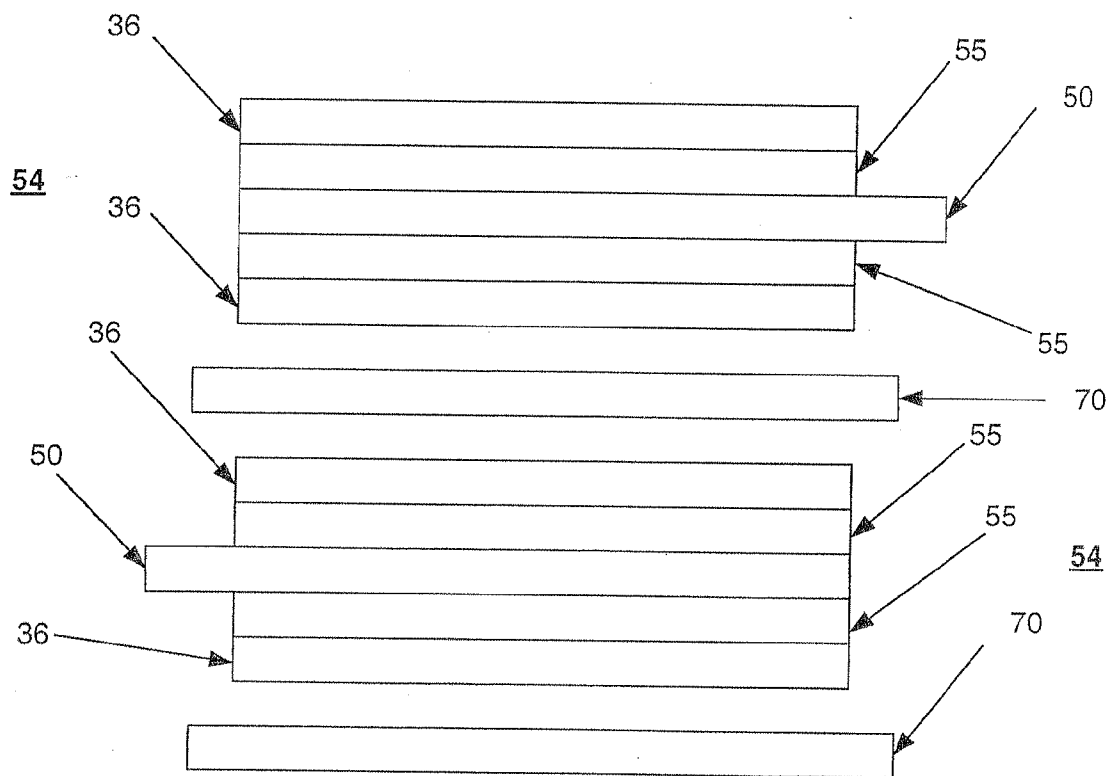

Fig. 4a

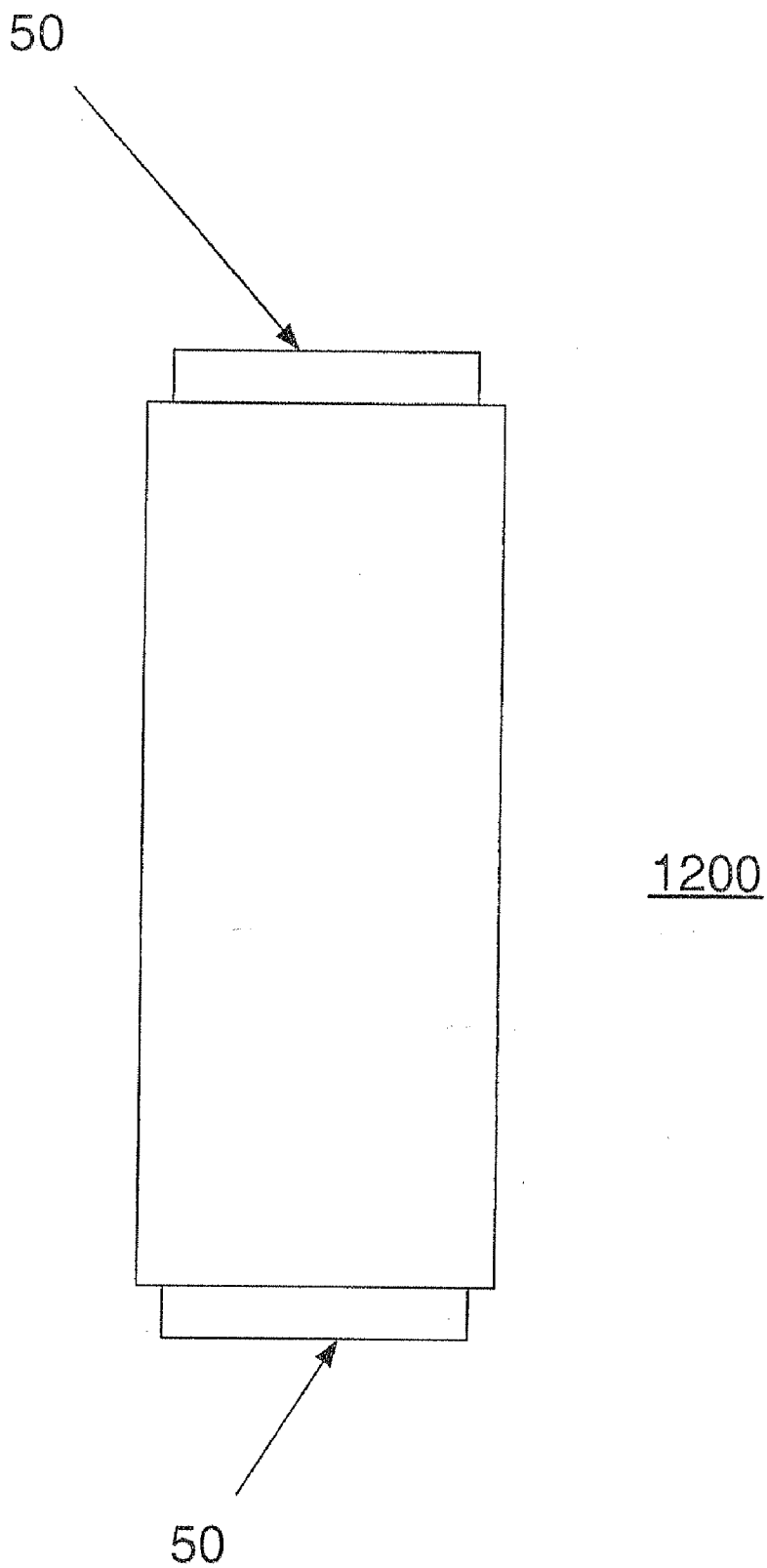

Fig. 4b

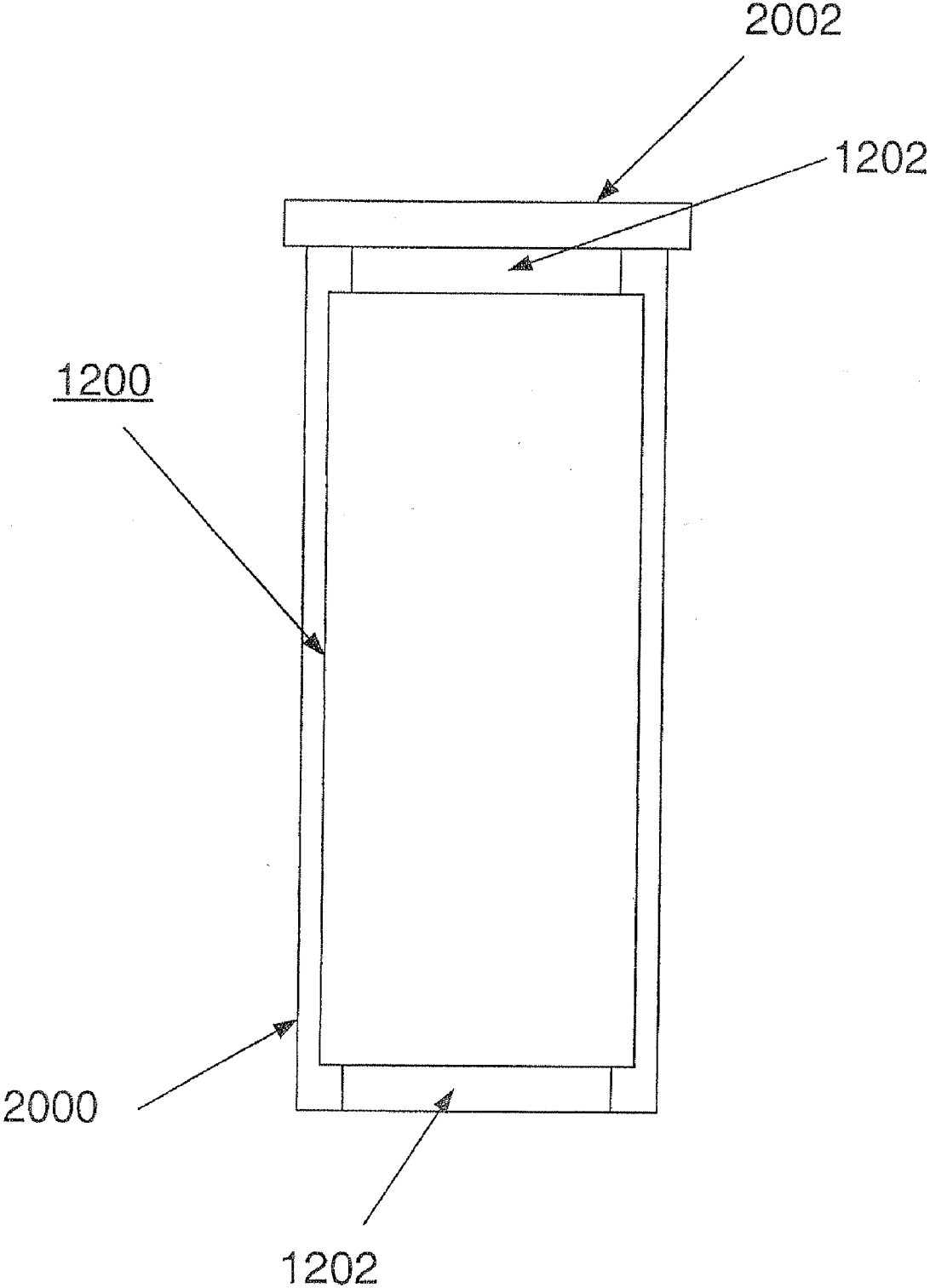

Fig. 5

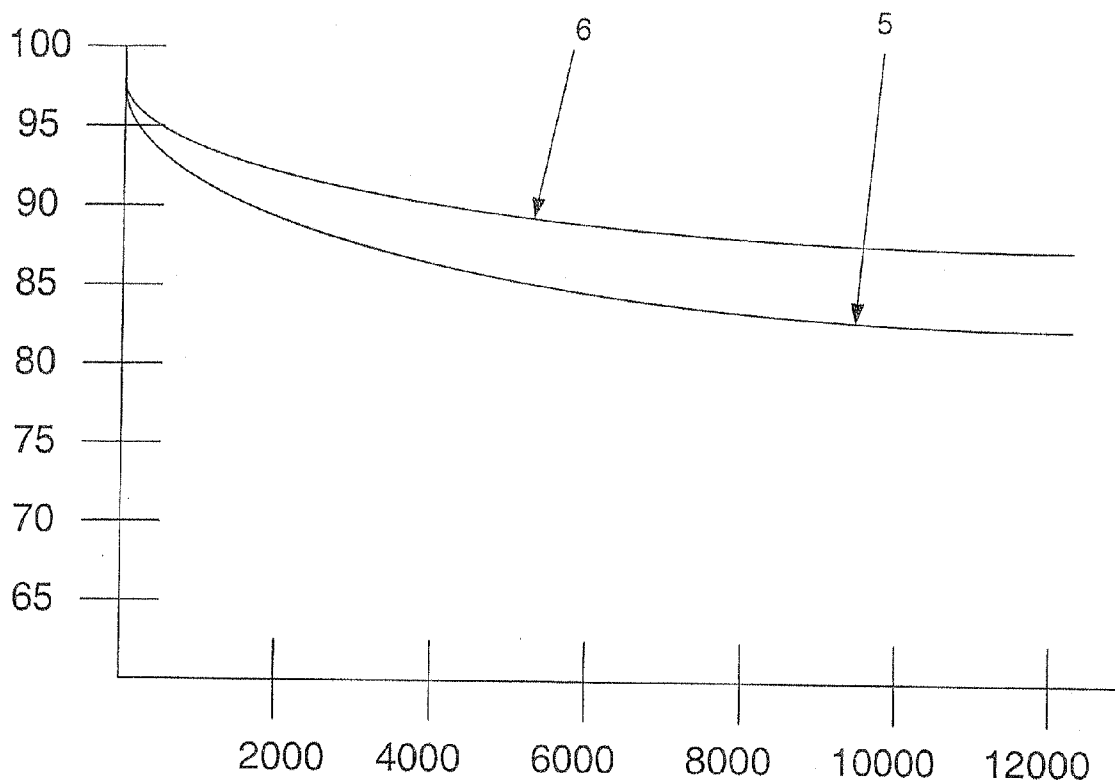

Fig. 6

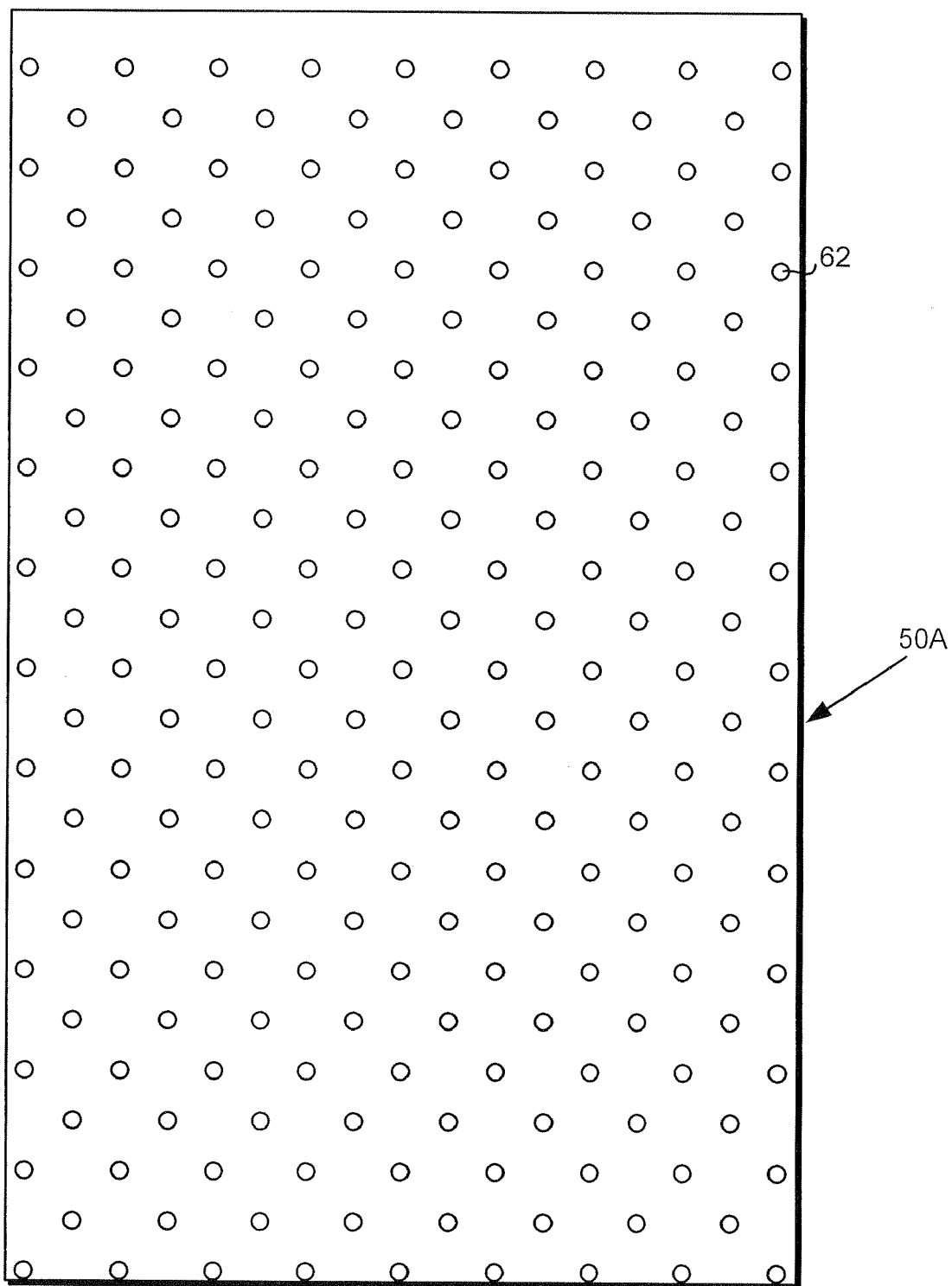

Fig. 7

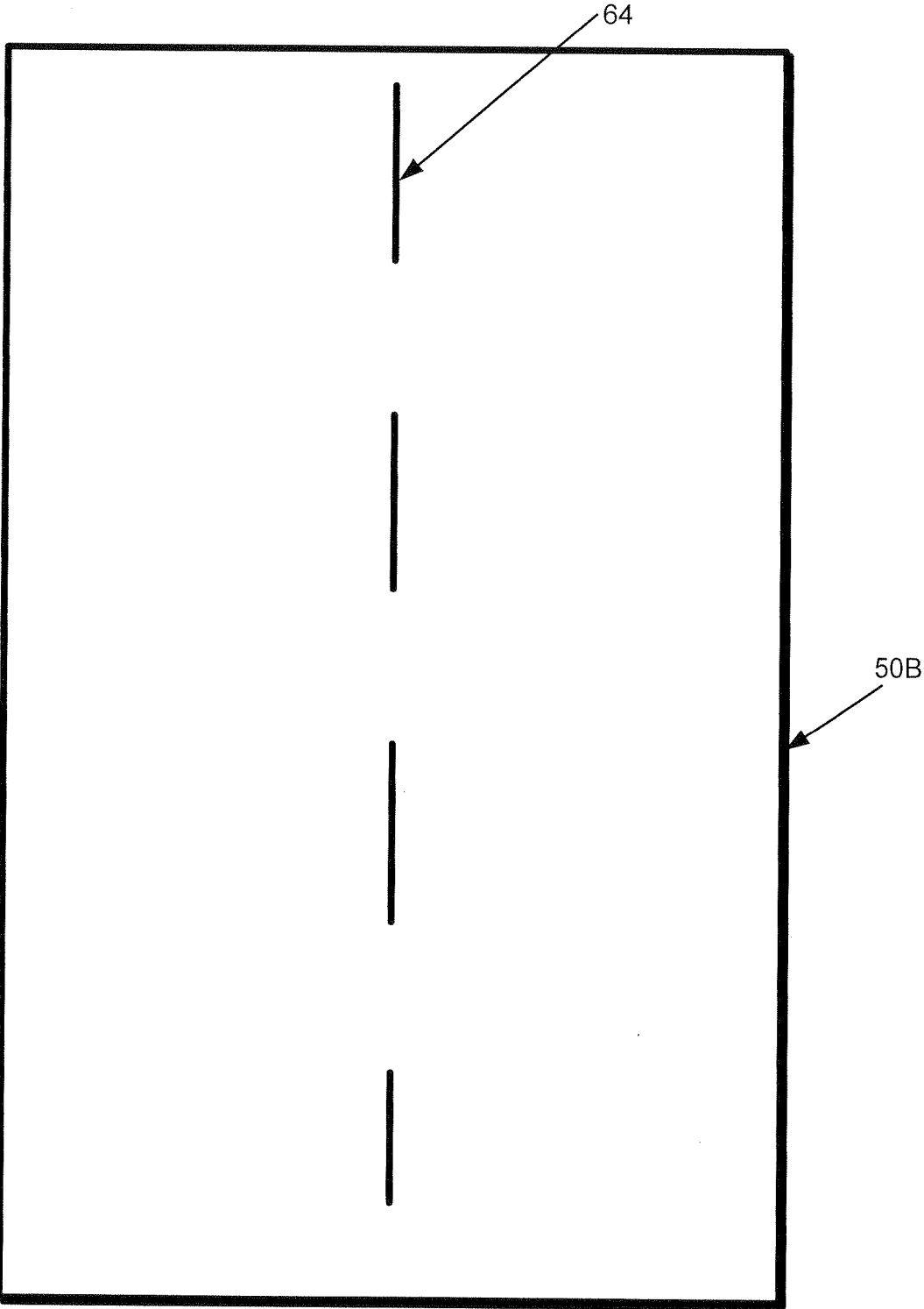

Fig. 8

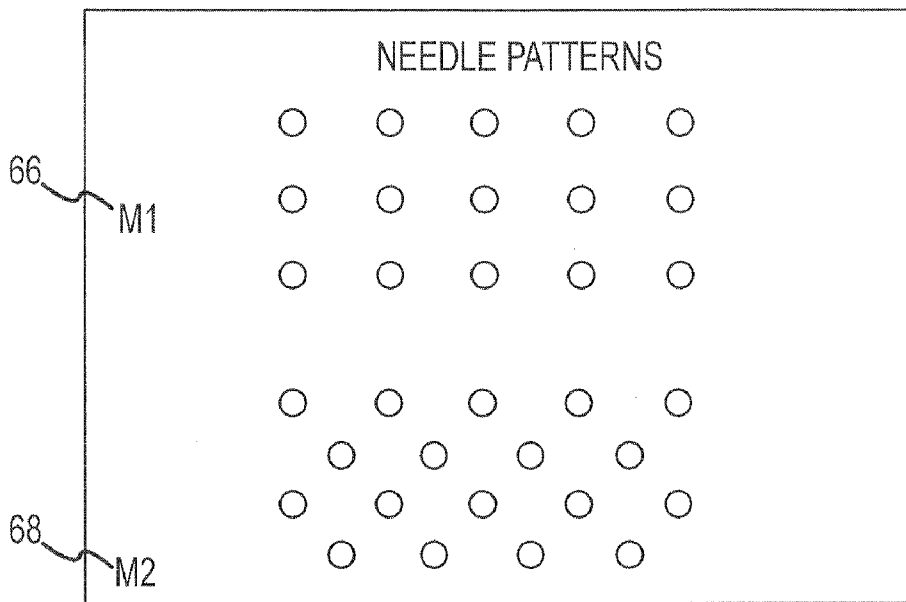

FIG.9

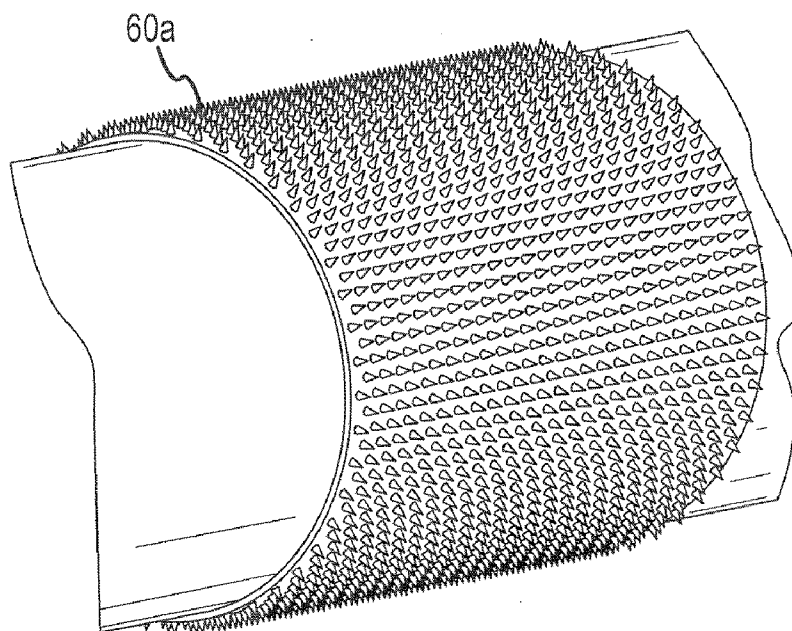

FIG.10

ELECTRODE FOR ENERGY STORAGE DEVICE

CROSS-REFERENCE TO RELATED APPLICATIONS

[0001] This application claims the benefit of U.S. provisional application No. 60/852,459, filed by Linda Zhong and Xiaomei Xi on 17 Oct. 2006, which is hereby incorporated by reference as though fully set forth herein.

FIELD OF INVENTION

[0002] The present invention relates generally to the field of energy storage devices. More particularly, the present invention relates to current collectors and electrodes for energy storage devices.

BACKGROUND INFORMATION

[0003] Energy storage devices that are used to power modern technology are numerous. Such energy storage devices include capacitors, batteries, and fuel cells. With each type of device are associated positive and negative characteristics. Based on these characteristics, decisions are made as to which device is more suitable for use in a particular application. Overall performance of a device is an important characteristic that can make or break a decision as to whether a particular type of device is used.

[0004] Many energy storage device configurations comprise the formation a stack or roll of electrode layers. This roll or stack of electrode layers is impregnated with an electrolyte and placed within a sealed container with electrical terminals connected to respective electrodes.

[0005] Double-layer capacitors, also referred to as ultra-capacitors and super-capacitors, are one type of energy storage device. Double-layer capacitors are able to store more energy per unit weight and unit volume than capacitors made with traditional technology. Double-layer capacitors store electrostatic energy in a polarized electrode/electrolyte interface layer. Double-layer capacitors include two electrodes, which are separated from contact by a porous separator. The separator prevents an electronic (as opposed to an ionic) current from shorting the two electrodes. Both the electrodes and the porous separator are immersed in an electrolyte, which allows flow of the ionic current between the electrodes and through the separator. At the electrode/electrolyte interface, a first layer of charged species is formed, and a second layer is charged species is formed in a solvent dipole (hence, the name "double-layer" capacitor).

SUMMARY

[0006] Improvements in impregnation and performance of electrodes used in energy storage devices, such as batteries, fuel cells, and double layer capacitors, is provided.

[0007] An energy storage device comprising a current collector disposed adjacent to an electrode is provided. The current collector comprises a plurality of voids extending through the current collector to allow electrolyte and ions of the electrolyte to flow through the current collector to the adjacent electrode to impregnate the electrode and to shorten ion travel distance preventing or reducing localized electrolyte starvation within an energy storage device.

[0008] In one embodiment, the current collector comprises a ratio of a surface area of a solid surface of the current

collector to a total surface area of the current collector is at least about fifty percent. In another embodiment, the current collector comprises a ratio of a surface area of a solid surface of the current collector to a total surface area of the current collector is at least about eighty percent. In one example, the ratio of a solid surface of the current collector to a total surface area of the current collector is at least about ninety percent.

[0009] In another embodiment, the plurality of voids of the current collector is formed without substantially reducing a surface area of a conductive material of the current collector. The plurality of voids, for example, may comprise a plurality of perforations and/or a plurality of slits extending through the thickness of the current collector.

[0010] In one embodiment, a double layer capacitor comprises an electrode comprising a solid current collector and a porous electrode. The solid current collector comprises a plurality of voids extending through a thickness of the current collector.

[0011] A method of preparing an electrode and current collector product is also provided. The method comprises providing an electrode; providing a current collector; disposing the current collector adjacent to the electrode; and creating a plurality of voids extending through a thickness of the current collector without reducing a surface area of the current collector by more than about fifty percent. In one embodiment, the plurality of voids are formed without reducing a surface area of the current collector disposed adjacent to the electrode by no more than about forty percent. In another embodiment, the plurality of voids are formed without reducing a surface area of the current collector disposed adjacent to the electrode by no more than about thirty percent, no more than about twenty percent, or no more than about ten percent. In one embodiment, the operation of creating a plurality of voids comprises perforating the current collector. In another embodiment, the operation of creating a plurality of voids comprises slitting the current collector. In yet another embodiment, the operation of creating comprises punching out portions of the current collector.

BRIEF DESCRIPTION OF THE DRAWINGS

[0012] FIG. 1 is a block diagram illustrating a process for making a particle based energy storage device.

[0013] FIG. 2 illustrates an apparatus used for forming one or more energy device structure.

[0014] FIG. 3 illustrates an apparatus used to bond an electrode film to a current collector.

[0015] FIG. 4a illustrates an electrode.

[0016] FIG. 4b illustrates a jellyroll.

[0017] FIG. 5 illustrates a jellyroll inserted into an open end of a housing.

[0018] FIG. 6 illustrates capacitance vs. number of full charge/discharge charge cycle tests of a prior art energy storage device 5 and an energy storage device 6.

[0019] FIG. 7 illustrates an embodiment of a current collector comprising a plurality of perforations extending through a thickness of the current collector.

[0020] FIG. 8 illustrates an embodiment of a current collector comprising a plurality of slits extending through a thickness of the current collector.

[0021] FIG. 9, for example, shows two embodiments of pin patterns that may be used with a perforator.

[0022] FIG. 10 shows one example of a perforator roll.

DESCRIPTION OF THE PREFERRED EMBODIMENTS

[0023] Reference will now be made in detail to embodiments of the invention that are illustrated in the accompanying drawings. Wherever possible, same or similar reference numerals are used to refer to same or similar steps and/or elements used therein.

[0024] As the number of electrode layers of an energy storage device increases, different factors can affect performance of the energy storage device. One factor is the ability of the stack or roll of electrode layers to be impregnated with electrolyte. As the dimensions of a stack or roll of electrode layers increases, adequate impregnation becomes more difficult to achieve. Energy storage devices often include a solid layer, such as a current collector foil that runs substantially a length and a width of an electrode of an energy storage cell.

[0025] In order to impregnate the electrode of the energy storage cell, the electrolyte follows an impregnation path through the cell. In a jelly roll configuration of an energy storage cell, for example, a solid current collector within the roll may prevent the electrolyte from reaching sections of the electrodes except through one or both of the longitudinal ends of the cell. The electrolyte thus impregnates the electrodes of the cell by traveling through the end(s) of the cell. Sometimes such a tortuous impregnation path results in dry locations of the electrode where electrolyte does not impregnate the entire electrode. The longer path also affects ion migration within the electrolyte during charge—discharge cycles and can lead to localized electrolyte starvation where ions are trapped and cannot migrate to certain areas of the electrode.

[0026] While a mesh wire current collector may allow electrolyte to flow through the current collector to impregnate an electrode, the mesh wire of the current collector provides a significant increase in equivalent series resistance (ESR) due to the decrease in surface area of the collector making contact with the electrode. Thus, electrons within the electrode must travel farther within a less conductive electrode than if the current collector covered more of the surface area of the adjacent electrode.

[0027] In addition, as the energy storage devices cycle through charge—discharge cycles, ions of electrolyte located within small locations in or near the electrodes may migrate away from active materials of the electrodes. The migration of these ions away from a particular region of the electrode may leave a region of the electrolyte with fewer ions than desired. Such a shortage of ions may lead to a condition of local electrolyte starvation. Local electrolyte starvation will lead to a decrease in capacity of an energy storage device. In a double layer capacitor, for example, electrolyte starvation may contribute to a decrease in capacitance or a “capacitance fade.”

[0028] Providing voids extending through a substantially solid current collector improves impregnation and shortens ion travel distance to prevent or reduce localized electrolyte starvation within an energy storage device.

[0029] Although particular embodiments are described including improved impregnation and performance of electrodes in double-layer capacitors, those skilled in the art will identify from this disclosure that these principles also find applicability with capacitors, batteries, fuel cells, hybrid cells, and other types of energy storage devices that utilize stacked or rolled electrodes.

[0030] FIG. 1, described below, provides merely one example of an electrode film and a process for forming that electrode film that may be used in combination with a current collector having a plurality of voids extending through a thickness of the current collector to allow electrolyte to pass through the current collector. The film described with reference to FIG. 1, for example, can be used in a double layer capacitor. Other types of electrode film both for double layer capacitors and other energy storage devices are contemplated and would be recognized by one of ordinary skill in the art after reviewing this disclosure. In addition, other processing methods may be used.

[0031] Referring now to FIG. 1, a block diagram illustrating an example of one type of process for making a particle based film for an energy storage device is shown. The process shown in FIG. 1 begins by blending activated carbon particles 12 and binder 16 together. Optionally, conductive particles 14 may also be blended together with the activated carbon particles 12 and the binder 16. The activated carbon particles 12, conductive particles 14 (where used), and the binder 16 may be blended together with or without any processing aides or additives, such as used in coating or extruding processes (hereafter referred throughout as “processing additive” and “additive”), including without limitation: added solvents, liquids, lubricants, plasticizers, and the like.

[0032] Where no processing additives are used, for example, dry activated carbon, dry binder, and dry conductive carbon (where used) can be combined and processed dry without any additives that may later need to be removed (e.g., via a drying step). In other embodiments, such processing additives may be added to the activated carbon, binder, and conductive particles (where used). In such embodiments, for example, it will be understood by those skilled in the art that electrode films may be made by extrusion, coating and other processes known to those skilled in the art. While such additives can be utilized in the manufacture of an electrode for an energy storage device, the operating lifetime, and maximum operating voltage of the energy storage device may become reduced, for example, because of undesirable chemical interactions that may occur between residues of the additive(s) and a subsequently used electrolyte.

[0033] In one embodiment, dry binder 16 refers to particles of an inert dry binder. In one embodiment, conductive particles 14 comprise at least one of dry conductive graphite particles, an electrically conductive polymer, a metal powder, or the like. In one embodiment, binder 16 comprises a fibrillizable flouropolymer, for example, polytetrafluoroethylene (PTFE) particles. Other possible fibrillizable binders include ultra-high molecular weight polypropylene, poly-

ethylene, co-polymers, polymer blends, and the like. It is understood that other active materials, binder, and optional conductive materials may also be used. In one embodiment, particular mixtures of activated carbon particles **12**, conductive particles **14**, and binder **16** comprise about 50% to 99% activated carbon, about 0% to 30% conductive carbon, and/or about 1% to 50% binder weight. In a more particular embodiment, particle mixtures include about 80% to 90% activated carbon, about 0% to 15% conductive carbon, and about 3% to 15% binder weight. In other embodiments, one or more of the particles may comprise, for example, carbon, graphite, intercalated carbon, conductive carbon, catalyst impregnated carbon, metal, metal oxide, manganese dioxide, thermoplastic, homo and copolymers, olefinic oxides, rubbers, butadiene rubbers, nitrile rubbers, polyisobutylene, poly(vinylesters), poly(vinylacetates) polyacrylate, fluorocarbon polymers, non-fibrillizable binder, thermoset particles, radiations set particles, thermoplastic, and/or other particles. Suitable particles are available from a variety of sources as would be known to those skilled in the art.

[0034] In step **18**, particles of activated carbon, conductive carbon, and binder provided by respective operations **12**, **14**, and **16** are blended together to form a mixture. The mixture may, for example, comprise a dry mixture of the activated carbon **12**, the conductive particles **14** (where used), and the binder **16** without any processing additives or may include any dry or wet processing additives. In one embodiment, for example, dry activated carbon particles **12**, dry conductive particles **14**, and dry binder **16** are blended for 1 to 10 minutes in a V-blender that is equipped with a high intensity mixing bar, until a uniform dry mixture is formed. Those skilled in the art will identify that blending time can vary based on batch size, materials, particle size, densities, as well as other properties. With reference to blending operation **18**, in one embodiment, particle size reduction and classification can be carried out as part of the blending step **18**, or prior to the blending step **18**. Size reduction and classification may improve consistency and repeatability of the resulting blended mixture and, consequently, of the quality of the electrode films and electrodes fabricated from the dry blended mixture.

[0035] In operation **20** the blended particles undergo an application of impact and shear force. The particles are then fed in operation **22**, and are calendered in operation **24** to provide a film. The film is bonded to a current collector (as described in further below) in operation **26**.

[0036] Referring now to FIG. 2, and preceding Figures as needed, there is seen one example of an apparatus used for forming one or more film for use as an electrode that may be incorporated into an energy storage device. In one embodiment, dry blended particles (such as from step **22** in FIG. 1) are provided to a device **41**, which compacts and/or calenders the particles to form them into a dry film. The compacting and/or calendaring function provided by device **41** can be achieved by a roll-mill, calendar, a belt press, a flat plate press, and the like, as well as others known to those skilled in the art. Thus, although shown in a particular configuration, those skilled in the art will understand that variations and other embodiments of device **41** could be provided to achieve one or more of the benefits and advantages described herein, which should be limited only by the claims that follow. In one embodiment, a resulting compacted dry

film **34** exits from a first roll-mill **32** and may become self-supporting after only one compacting pass through the roll-mill **32**.

[0037] Particular dry films may comprise, for example, lengths of any desired length, thickness between about 10 μm to 2 mm, and widths from on the order to meters to 10 mm or smaller. In one embodiment, a width is about 30 mm and a thickness is about 150 μm . The ability to provide a self-supporting film differs from that of some films where folding/kneading steps and/or multiple compacting/calendering steps are used to strengthen films to give them the tensile strength needed for subsequent handling and processing. Because a dry film provided herein can be sufficiently self-supporting after one pass through a roll-mill **32**, it can easily and quickly be formed into a long integral continuous sheet, which can be rolled for subsequent use in a commercial scale manufacture process. A dry film can be formed as a self-supporting sheet that is limited in length only by the capacity of the rewinding equipment. Thus, compared to some prior art additive based films, which are described as non-self supporting and/or as small finite area films, the dry self-supporting films described herein are more economically suited for large scale commercial manufacture.

[0038] The dry film **34** can be separated from the roll-mill **32** using a doctor blade, or the edge of a thin strip of plastic, or other separation material, including metal or paper. Once the leading edge of the dry film **34** is separated, the weight of the self-supporting dry film and film tension can act to separate any remaining exiting dry film **34** from the roll-mill **32**. The self-supporting dry film **34** can be fed through a tension control system **36** into another set of rollers **38**. The rollers **38** may further compact and density the dry film **34**. Additional calendering steps **40** can be used to further reduce the dry film's thickness and to increase tensile strength. A slitting machine **44** may then be used to cut the current collector to a desired width before it is wound onto a storage roll **48**.

[0039] The process shown in FIG. 2 is merely one example of a process for providing a film for use as an electrode of an energy storage device, such as a battery, fuel cell, or double layer capacitor. Other methods of providing films for electrodes may also be used. For example, a slurry including activated carbon, a conductive material (where used), a binder, and a processing additive may be coated onto a substrate (e.g., a current collector or sacrificial layer) and dried to form the film. In another example, a mixture including activated carbon, conductive material (where used), binder, and a processing additive may be extruded into a film for use as an electrode.

[0040] Referring to FIG. 3, and preceding Figures as needed, there is seen an apparatus used to bond an electrode film to a current collector. In step **28**, a dry film **34** is bonded to an electrically conductive collector **50**. In one embodiment, collector **50** may have deposited thereon one or more layer of adhesive. In one embodiment, the collector **50** may comprise a foil. In some embodiments, the current collector may comprise an etched or unetched foil or sheet of conductive material or a roughened or unroughened foil or sheet of conductive material. In one embodiment, the current collector **50** comprises a thickness of about 30 microns. Material with other thickness is also within the scope of the

invention. Materials with other thickness may also be used. In one embodiment, the current collector **50** comprises aluminum or copper. Those skilled in the art will recognize that if the electrochemical potential allows, the other metals could also be used as a collector **50**.

[0041] In one embodiment, a current collector **50** and two dry film(s) **34** are fed from storage rolls **48** into a heated roll-mill **52** such that the current collector **50** is positioned between two self-supporting dry films **34**. In one embodiment, the current collector **50** may be pre-heated by a heater **79**. In one embodiment, a roll-mill **52** temperature at the nip of the roll is between 100° C. and 300° C. In one embodiment, the nip pressure is selected between 50 pounds per linear inch (PLI) and 1000 PLI. Each dry film **34** becomes calendered and bonded to a side of the current collector **50**. In one embodiment, the resulting dry electrode **54** can be S-wrapped over chill rolls **56** to set the dry film **34** onto the collector **50**.

[0042] The dry electrode **54** can then be collected onto another storage roll **58**. Tension control systems **51** can also be employed by the system shown in FIG. 3. It is identified that other means, methods, and setups for bonding of electrode films to a current collector can be used to form electrodes, as are known to those skilled in the art. For example, in other embodiments, a prior art additive-based electrode film could be bonded to a current collector **50**. Additive-based electrode films include those made by coating, extrusion, and other processes known to those skilled in the art.

[0043] FIG. 3 further shows a perforator **60** located between the chill rolls **56** and the storage roll **58**. In this embodiment, the perforator **60** perforates the combined electrode and current collector structure **54**. The perforator **60** may, however, be disposed in any other location of the process shown in FIG. 3. For example, the perforator **60** may be used to perforate the current collector before it is combined with a film electrode (e.g., before it is wound on roll **48**, after a coating step, or between roll **48** and the heated roll-mill **52**). In such an embodiment, the current collector is perforated with the electrode film remaining intact. In another embodiment, the perforator **60** may be used to perforate the combined electrode and current collector structure **54** between the heated roll-mill **52** and the chill rolls **56** or after it has been wound onto the storage roll **58**.

[0044] In one embodiment, the perforator **60** comprises needles having a diameter of approximately 0.78 mm that are arranged in a pattern having a density of about 100 pins per square inch. FIG. 9, for example, shows two embodiments **66** and **68** of pin patterns that may be used with the perforator. Other arrangements may also be used. In addition, FIG. 10 shows one example of a perforator roll **60a** that may be used in the perforator **60** of FIG. 3. In one embodiment, the perforator perforates the current collector **50** without substantially diminishing the surface area of the current collector available for contact with the electrode film in order to not substantially increase the equivalent series resistance of the electrode. In one embodiment, the perforation of the current collector results in little or no material being removed from the current collector. In this embodiment, perforations formed in the current collector allow electrolyte and ions to move through the perforations of the current collector but maintain all or at least substantially the

same surface area of the current collector available for contact with the adjacent electrode film. Thus, the equivalent series resistance of the electrode and current collector is not increased substantially.

[0045] Although a mesh or screen current collector or a current collector with a substantial portion of its surface area removed (e.g., by removing substantial portions of the current collector by punching) may provide for openings through which an electrolyte may flow, such a current collector will provide an increased equivalent series resistance (ESR) because electrons from a portion of the electrode must travel farther through the higher-resistance electrode film to reach an available conductive surface of the current collector.

[0046] In another embodiment, a slitter may be used to slit the current collector **50** either by itself or in combination with one or more electrode film disposed adjacent to the current collector. Again, a slit in the electrode provides a path for electrolyte and ions to move through the current collector without substantially decreasing the surface area of the current collector available for electrical contact with the electrode film. Any number of patterns or locations of slits may be used to slit the current collector.

[0047] In yet another embodiment, voids in the current collector **50** may be created by other methods, such as by punching relatively small holes in the current collector **50** either by itself or in combination with one or more electrode film disposed adjacent to the current collector. In this embodiment, the surface area of the remaining current collector available for electrical contact with an adjacent electrode is at least fifty percent of the total surface area of the current collector disposed adjacent to the electrode before the holes are punched. In other embodiments, the surface area of the remaining current collector available for electrical contact with an adjacent electrode is at least sixty percent, seventy percent, or eighty percent of the total surface area of the current collector before the holes are punched. In another embodiment, the surface area of the remaining current collector available for electrical contact with an adjacent electrode is at least ninety percent of the total surface area of the current collector before the holes are punched. In yet another embodiment, the surface area of the remaining current collector available for electrical contact with an adjacent electrode is at least ninety-five percent of the total surface area of the current collector before the holes are punched. In another embodiment, the surface area of the remaining current collector available for electrical contact with an adjacent electrode is at least ninety nine percent of the total surface area of the current collector before the holes are punched.

[0048] Again, the availability of the remaining conductive surface area of the current collector adjacent to an electrode provides a path for electrolyte and ions to move through the current collector without decreasing the surface area of the current collector available for electrical contact with the electrode film so far as to increase the equivalent series resistance (ESR) of the combined electrode and current collector structure beyond an acceptable point. In one embodiment, for example, the voids formed in the current collector reduce a surface area of a current collector disposed adjacent to an electrode by no more than about fifty percent. In another embodiment, the voids formed in the

current collector reduce a surface area of a current collector disposed adjacent to an electrode by no more than about thirty five percent. In yet another embodiment, the voids formed in the current collector reduce a surface area of a current collector disposed adjacent to an electrode by no more than about twenty percent.

[0049] Referring now to FIG. 4a, and preceding Figures as needed, structures of an example electrode of an energy storage device, such as a battery, fuel cell, or double layer capacitor are shown. In FIG. 4a, there are shown cross-sections of four electrode films 36, which are bonded to a respective current collector 50. First surfaces of each of the films 36 are coupled to respective surfaces of a current collector 50 to form a top electrode 54 and bottom electrode 54. In one embodiment, an electrode includes a top and bottom separator 70. In one embodiment, bonding of electrode films 36 to a respective current collector may be enhanced by use of an intermediate adhesive layer 55. In one embodiment, separators 70 may comprise a porous electrically insulating layer or film or paper sheet of about 30 microns in thickness. Separators with other thickness and other material may also be used. In one embodiment, a combination of current collectors, separators, and electrode films disclosed herein is formed into a configuration known by those skilled in the art as a jellyroll.

[0050] Referring now to FIG. 4b, a jellyroll is shown. In one embodiment, sheets of structures shown in FIG. 4b are positioned one on top of another and rolled into a jellyroll 1200 type structure such that one collector 50 extends from one end of the jellyroll and another collector 50 extends from an opposing end. The extending ends of the collectors 50 provide contact points where electrical contact may be made with the jellyroll.

[0051] Referring now to FIG. 5, and preceding Figures as needed, during manufacture, a jellyroll 1200 made according to one or more of the embodiments disclosed herein is inserted into an open end of a housing 2000. An insulator (not shown) is placed along a top periphery of the housing 2000 at the open end, and a cover 2002 is placed on the insulator. During manufacture, the housing 2000, insulator, and cover 2002 may be mechanically curled together to form a tight fit around the periphery of the now sealed end of the housing, which after the curling process is electrically insulated from the cover by the insulator. When disposed in the housing 2000, respective exposed collector extensions 1202 of electrode 1200 make internal contact with the bottom end of the housing 2000 and the cover 2002. In one embodiment, external surfaces of the housing 2000 or cover 2002 may include or be coupled to standardized connections/connectors/terminals to facilitate electrical connection to the rolled electrode 1200 within the housing 2000. Contact between respective collector extensions 1202 and the internal surfaces of the housing 2000 and the cover 2002 may be enhanced by welding, soldering, brazing, conductive adhesive, or the like. In one embodiment, a welding process may be applied to the housing and cover by an externally applied laser welding process. In one embodiment, the housing 2000, cover 2002, and collector extensions 1202 comprise substantially the same metal, for example, aluminum. An electrolyte suitable for a desired application or performance characteristic can be added through a filling/sealing port (not shown) to the sealed housing 1200. After

impregnation and sealing, a finished product may, thus, be made ready for sale and/or subsequent use.

[0052] Referring now to FIG. 6, there are seen a graph illustrating capacitance vs. number of full charge/discharge cycle tests of an energy storage device 5 that uses a solid current collector without voids extending through the current collector, and an energy storage device 6 that uses a current collector including a plurality of slits extending through a thickness of the current collector in order to allow electrolyte and ion movement through the current collector (as shown below in FIG. 8).

[0053] Those skilled in the art will identify that energy storage devices are typically derated to reflect performance degradation that occurs during initial first use or burn-in. For example, in the prior art, after a first 10000 cycles or so of use, the performance of a 2900 Farad capacitor may become degraded such that it may be able to provide only 2600 Farads of capacitance. Consequently, manufacturers of what would initially be a 2900 Farad double-layer capacitor typically have to rate such capacitors as a nominal 2600 Farads. Such derating of energy storage devices undesirably implicates that performance, manufacturing costs, and/or profits may be needlessly wasted.

[0054] With further reference to FIG. 6, an initial capacitance of devices 5 and 6 in an unused state was about 2800 Farad. The test conditions were such that at room temperature, both devices 5 and 6 were full cycle charged at 100 amps to 2.7 volts and then discharged to 1.25 volts. Both devices were charged and discharged in this manner with 15 seconds of rest between cycles. The tests were performed for approximately 12,000 cycles for the prior art device 5, and for approximately 12,000 cycles for the device 6. As shown, the device 5 experienced a drop of about 17% in capacitance over 12,000 full charge cycles, whereas device 6 experienced only a drop of about 12% in capacitance.

[0055] Referring now to FIG. 7, there is seen an embodiment of a current collector 50A for use in an energy storage device comprising a plurality of perforations 62. The current collector 50A comprises a thickness, a width, and a length. The perforations in the current collector 50A extend through the thickness of the current collector 50A. The perforations 62 may, for example, be arranged along the width and/or the length of the current collector 50A. In one embodiment, the perforations 62 are formed during or after formation of the current collector 50A, as could be implemented by those skilled in the art. The perforations may also be formed before or after the current collector 50A is combined with at least one electrode film. In one embodiment, the perforations 62 may be formed by cutting or punching (e.g., by perforator needles) through the current collector 50A. In one embodiment, the perforations 62 may be formed by mechanical contact forces as applied by an instrument, or non-mechanically, as by application of a beam of energy. In one embodiment, the perforations 62 may comprise other geometries, for example, circular, oval, elongated, and the like. In one embodiment, the perforations 62 are spaced at equal intervals along the collector length and/or width. In one embodiment, the perforations 62 are spaced at unequal intervals along the length and/or width. In one embodiment, the perforations 62 are centrally disposed between a width of, and along a length of, the collector. In one embodiment, the voids are disposed across the entire surface of the current

collector 50A. In one embodiment, one or more of the perforations 62 may be formed after or during calendaring of an electrode film onto the collector. In one embodiment, the perforations 62 are formed in a collector after an electrode film is formed on, or bonded to, a current collector, in which case it is understood that corresponding perforations 62 could, thus, be formed in the electrode film as well.

[0056] Referring now to FIG. 8, an embodiment of a current collector 50B including a plurality of slits 64 is shown. In FIG. 8, the current collector 50B comprises a thickness, a width, and a length. In one embodiment, the current collector 50B comprises a plurality of slits 64 formed by making slits 64 through the thickness and along the length of the current collector 50B. In one embodiment, the slits are formed by mechanical slitting (e.g., by mechanical contact) or by non-mechanical cutting (e.g., by application of a beam of energy). In one embodiment, the slits 64 are formed during or after formation of the current collector 50B, as could be implemented by those skilled in the art. In one embodiment, the slits 64 are spaced at equal intervals along the collector length and/or width of the current collector 50B. In one embodiment, the voids are spaced at unequal intervals along the length and/or width of the current collector 50B. In one embodiment, the slits 64 are centrally disposed between a width of, and along a length of, the collector. In one embodiment, the slits 64 are disposed across the entire surface of the collector. In one embodiment, one or more of the slits 64 may be formed after or during calendaring of an electrode film onto the collector. In one embodiment, the slits 64 are formed in the current collector after an electrode film is formed on, or bonded to, a collector, in which case it is understood that corresponding slits 64 could, thus, be formed in the electrode film as well.

[0057] As described above with respect to FIG. 6, a certain amount of capacitance drop is experienced during the first 12,000 cycles of use of a double layer capacitor 5 including a solid current collector not having a plurality of voids extending through the current collector. The inventors have identified that, at least in part, such capacitance drop is due to unequal distribution of electrolyte within the structures of a jellyroll (i.e. local electrolyte starvation). It has been identified that after 12000 cycle testing of a capacitor 5, when the capacitor is opened, and electrode films used in the manufacture of the capacitor are viewed, many areas of dryness on the electrode films can be visually identified. Such dryness indicates that electrolyte has not sufficiently penetrated within the structures of the capacitor. In the case of a jellyroll type capacitor cell, when electrolyte is introduced within a housing to impregnate the jellyroll, it is desired that electrolyte become evenly distributed within the jellyroll. Without a plurality of voids in a current collector, the impregnation typically occurs by diffusion of electrolyte that starts at the ends of the jellyroll that have exposed collectors, and then inward between the layers of wound electrode films and towards a centermost point within jellyroll. Because the electrode film layers are typically wound under tension, it is identified that the spacing between successive wound electrode layers is reduced. It is identified that as the spacing between layer decreases, adequate diffusion and transport of electrolyte therebetween becomes more difficult to achieve. As well, as a jellyroll diameter and/or width is increased, as when increased capacitance is desired, the distance that electrolyte needs to traverse to

achieve complete impregnation of a jellyroll also increases, which further hinder diffusion or transport of electrolyte within a jellyroll.

[0058] Improved impregnation of electrode films of energy storage devices is provided. One or more voids formed through a current collector allows for electrolyte to more easily find a path to fully impregnate electrode films and other structures that comprise an electrode. In addition, the plurality of voids formed through the current collector provides for more electrolyte and ion transport per unit of time during cycled use of an energy storage device. In addition to impregnation of electrolyte that may occur through ends an electrode and then through layers of the electrode, impregnation may also occur through surfaces of the current collector. In the case of a jellyroll type electrode design, as well as with flat or stacked electrode designs that are known to those skilled in the art, electrolyte impregnation may, thus, be made to occur through surfaces of an electrode, not just through its ends. For example, after introduction within a housing, electrolyte may diffuse through a plurality of voids formed in a radially outermost portion of a collector and, thereafter, one or more other voids. In this manner, the voids provide a shorter path over which electrolyte diffusion or transport can occur to impregnate electrode structures within a jellyroll. The voids may also provide more paths for impregnation. Shorter and more paths for diffusion and impregnation path implicates that impregnation of one or more electrode structures may occur more quickly and more thoroughly. More efficient and rapid transport reduces in starvation of electrolyte within an energy storage device and, thus, reduces initial capacitance drop that is experienced when such energy storage device is used in a cycled manner. Referring back to FIG. 6, there is seen that for a device 6 that comprises a plurality of slit type voids formed along a collector of a jellyroll type electrode, an initial capacitance drop that is experienced over a first 12000 cycles of use is only about 12%. As compared to the capacitor 5 without the plurality of voids in the current collector, the reduced capacitance drop means that less capacitor material need be used in anticipation of a nominally specified capacitance, or for a given housing volume, a nominally specified capacitance can be greater.

[0059] Thus, the particular systems and methods shown and described herein in detail are capable of attaining the above described objects and advantages of the invention. However, the descriptions and drawings presented herein represent some, but not all, embodiments that have been practiced or that are broadly contemplated. For example, products, structures, and methods that are disclosed may comprise configurations, variations, and dimensions other than those disclosed. In one embodiment, an electro-chemical device made according to principles described herein may comprise two different electrode films that differ in composition and/or dimension (i.e. asymmetric electrodes). Housing and electrode designs may be implemented in coin-cell type, clamshell type, flat or stacked prismatic type, and cylindrical type geometries, as well as others as are known to those skilled in the art. For a particular type of housing, it is understood that appropriate geometrical changes to the embodiments described herein may be needed, but that such changes would be within the scope of those skilled in the art. The present invention should be therefore limited only by the appended claims.

1. An energy storage device electrode product comprising:

at least one current collector comprising plurality of voids extending through a thickness of the current collector, wherein the plurality of voids allow electrolyte to flow through the thickness of the current collector;

at least one electrode film disposed adjacent to and coupled to the at least one current collector,

wherein the plurality of voids extending through the current collector is formed without reducing a surface area of a conductive material of the current collector disposed adjacent to the electrode by more than about fifty percent.

2. An energy storage device electrode product according to claim 1 wherein the plurality of voids is formed without substantially reducing a surface area of a conductive material of the current collector disposed adjacent to the electrode.

3. An energy storage device electrode product according to claim 1 wherein the plurality of voids comprise a plurality of perforations.

4. An energy storage device electrode product according to claim 1 wherein the plurality of voids comprise a plurality of slits.

5. An energy storage device electrode product according to claim 1 wherein the plurality of voids comprise a plurality of punches.

6. An energy storage device electrode product according to claim 1 wherein the energy storage device electrode product comprises a jellyroll-type electrode cell design.

7. An energy storage device electrode product according to claim 1 wherein the energy storage device electrode product comprises an electrode of a stacked energy storage device design.

8. An energy storage device electrode product according to claim 1 wherein the energy storage device electrode product comprises an electrode of a double layer capacitor.

9. An energy storage device electrode product according to claim 1 wherein the plurality of voids are formed within a center portion of a width of the current collector.

10. A method of preparing an energy storage device electrode product comprising:

providing an electrode;

providing a current collector;

disposing the current collector adjacent to the electrode; and

creating a plurality of voids extending through a thickness of the current collector,

wherein the plurality of voids extending through the thickness of the current collector is formed without reducing a surface area of a conductive material of the current collector disposed adjacent to the electrode by more than about fifty percent.

11. A method of preparing an energy storage device electrode product according to claim 10 wherein the plural-

ity of voids is formed without substantially reducing a surface area of a conductive material of the current collector disposed adjacent to the electrode.

12. A method of preparing an energy storage device electrode product according to claim 10 wherein the plurality of voids comprise a plurality of perforations.

13. A method of preparing an energy storage device electrode product according to claim 10 wherein the plurality of voids comprise a plurality of slits.

14. A method of preparing an energy storage device electrode product according to claim 10 wherein the plurality of voids comprise a plurality of punches.

15. A method of preparing an energy storage device electrode product according to claim 10 wherein the energy storage device electrode product comprises a jellyroll-type electrode cell design.

16. A method of preparing an energy storage device electrode product according to claim 10 wherein the energy storage device electrode product comprises an electrode of a stacked energy storage device design.

17. A method of preparing an energy storage device electrode product according to claim 10 wherein the energy storage device electrode product comprises an electrode of a double layer capacitor.

18. A double layer capacitor comprising:

a first electrode comprising a first side and a second side, the first electrode comprising activated carbon and a binder;

a first current collector comprising a sheet of conductive material, the first current collector disposed adjacent the first side of the first current collector, wherein the first current collector comprises a plurality of voids extending through a thickness of the current collector, wherein the plurality of voids extending through the thickness of the current collector is formed without reducing a surface area of a conductive material of the current collector disposed adjacent to the electrode by more than about fifty percent;

a second electrode comprising a first side and a second side, the second electrode comprising activated carbon and a binder;

a second current collector disposed adjacent the first side of the second current collector; and

a separator disposed between the second side of the first electrode and the second side of the second electrode,

wherein the first electrode, the first current collector, the second electrode, the second current collector, and the separator are immersed in an electrolyte.

19. A double layer capacitor according to claim 18 wherein the plurality of voids is formed without substantially reducing a surface area of a conductive material of the current collector disposed adjacent to the electrode.

20. A double layer capacitor according to claim 18 wherein the plurality of voids comprise a plurality of perforations.

21. A double layer capacitor according to claim 18 wherein the plurality of voids comprise a plurality of slits.

22. A double layer capacitor according to claim 18 wherein the plurality of voids comprise a plurality of punches.

23. A double layer capacitor according to claim 18 wherein the first electrode, first current collector, second electrode, second current collector, and separator are arranged in a jellyroll-type electrode cell design.

24. A double layer capacitor according to claim 18 wherein the energy storage device electrode product comprises an electrode of a stacked energy storage device design.

25. A double layer capacitor according to claim 18 wherein the plurality of voids are formed within a center portion of a width of the first current collector.

* * * * *