



- (51) International Patent Classification:
F17C 1/06 (2006.01) F17C 1/16 (2006.01)
- (21) International Application Number:
PCT/IB2015/054540
- (22) International Filing Date:
16 June 2015 (16.06.2015)
- (25) Filing Language: English
- (26) Publication Language: English
- (30) Priority Data:
MI2014A001311 17 July 2014 (17.07.2014) IT
- (71) Applicant: **FABER INDUSTRIE S.P.A.** [IT/IT]; Via Dell' Industria, 23, I-33043 Cividale Del Friuli, UDINE (IT).
- (72) Inventors: **COLA, Gian Luigi**; c/o FABER INDUSTRIE S.p.A., Via Dell' Industria, 23, I-33043 Cividale Del Friuli, UDINE (IT). **DI SARNO, Raffaele**; c/o FABER INDUSTRIE S.p.A., Via Dell' Industria, 23, I-33043 Cividale Del Friuli, UDINE (IT).
- (74) Agents: **LEIHKAU, Steffen Falk et al.**; c/o JACOBACCI & PARTNERS S.p.A., Via Senato, 8, I-20121 Milano (IT).

- (81) Designated States (unless otherwise indicated, for every kind of national protection available): AE, AG, AL, AM, AO, AT, AU, AZ, BA, BB, BG, BH, BN, BR, BW, BY, BZ, CA, CH, CL, CN, CO, CR, CU, CZ, DE, DK, DM, DO, DZ, EC, EE, EG, ES, FI, GB, GD, GE, GH, GM, GT, HN, HR, HU, ID, IL, IN, IR, IS, JP, KE, KG, KN, KP, KR, KZ, LA, LC, LK, LR, LS, LU, LY, MA, MD, ME, MG, MK, MN, MW, MX, MY, MZ, NA, NG, NI, NO, NZ, OM, PA, PE, PG, PH, PL, PT, QA, RO, RS, RU, RW, SA, SC, SD, SE, SG, SK, SL, SM, ST, SV, SY, TH, TJ, TM, TN, TR, TT, TZ, UA, UG, US, UZ, VC, VN, ZA, ZM, ZW.
- (84) Designated States (unless otherwise indicated, for every kind of regional protection available): ARIPO (BW, GH, GM, KE, LR, LS, MW, MZ, NA, RW, SD, SL, ST, SZ, TZ, UG, ZM, ZW), Eurasian (AM, AZ, BY, KG, KZ, RU, TJ, TM), European (AL, AT, BE, BG, CH, CY, CZ, DE, DK, EE, ES, FI, FR, GB, GR, HR, HU, IE, IS, IT, LT, LU, LV, MC, MK, MT, NL, NO, PL, PT, RO, RS, SE, SI, SK, SM, TR), OAPI (BF, BJ, CF, CG, CI, CM, GA, GN, GQ, GW, KM, ML, MR, NE, SN, TD, TG).

Published:

— with international search report (Art. 21(3))

(54) Title: PRESSURE VESSEL

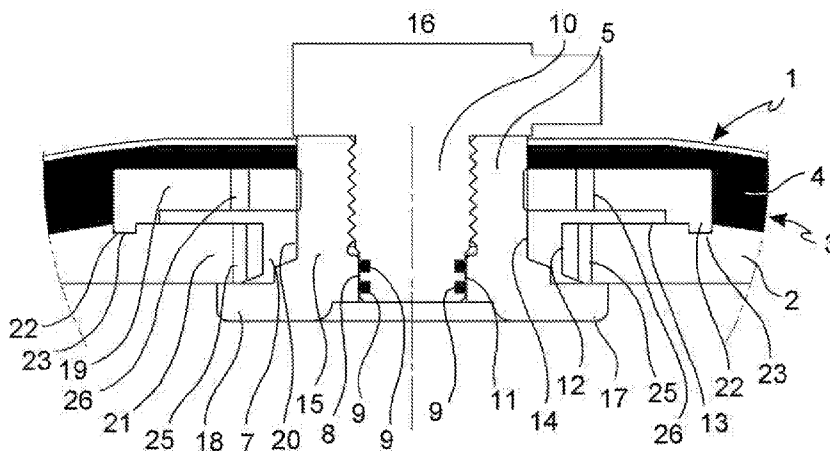

FIG. 5

(57) Abstract: Pressure vessel (1) with a gas-impermeable liner (2) and a reinforcing layer (4) in composite material formed externally around the impermeable liner (2), as well as at least one boss (5) coupled to the impermeable liner (2) and to the reinforcing layer (4), wherein between the impermeable liner (2) and the boss (5) a polymeric sealing mass (7) is arranged bound to both the impermeable liner (2) and to the boss (5) by means of in situ cross-linking of the sealing mass (7).



DESCRIPTION

"PRESSURE VESSEL"

[0001] The present invention relates to pressure vessels and, more particularly, to new systems and methods for pressure vessels in composite material surrounded by a reinforcing layer.

[0002] The development of advanced composite materials has enabled the creation of lightweight pressure vessels in wrapped composite material ("composite overwrap material") classified into different categories, such as the type 4 indicating pressure vessels with a non-metallic inner lining ("liner") and a composite reinforcement outer layer.

[0003] One of the critical aspects of making a type 4 pressure vessel is the interface between the non-metal inner liner and the metal "boss" which houses the valve and/or forms the connection of the pressure vessel with an external duct of fluid.

[0004] The interface between the non-metallic liner, typically plastic, and the metal boss must ensure an impermeable seal able to withstand cyclical pressurisation and depressurisation for the entire lifetime of the pressure vessel.

[0005] To this end it is known of to make the inner liner in plastic with a collar that projects in the axial

direction of the boss and extends inside the boss up to an internal threading for the screwing of the valve. The valve is provided with circumferential grooves which house sealing O-rings which, with the valve screwed into the boss, engage the collar of plastic liner and stress it radially outwards against the inner surface of the boss. This way an impermeable seal is achieved in the valve-O-ring-inner collar interface of the liner (figures 1a-d)

[0006] In a second prior solution, the plastic inner lining is not in direct contact with the boss but with an additional insert in thermoplastic material which extends inside the boss as far as the vicinity of the threading for screwing the valve. The valve is provided with circumferential grooves which house sealing O-rings which, with the valve screwed into the boss, engage the insert in thermoplastic material and stress it radially outwards against the inner surface of the boss. This way an impermeable seal is achieved in the valve-O-ring-insert and insert - internal liner interfaces (figures 2a-d).

[0007] Both prior solutions present a risk of permeability and of leakage along the O-rings, which increases with time and which is due to the "creep" phenomenon (a gradual plastic deformation depending on time and on the

condition of permanent stress) of the inner liner collar and of the insert of thermoplastic material in the areas of contact with the seals, as shown in figures 1d and 2d.

5 [0008] The purpose of the present invention is therefore to improve the coupling between the non-metal inner lining and the metal boss of type 4 pressure vessels so as to ensure permanent gas-impermeability.

[0009] These and other purposes are achieved by means of a
10 pressure vessel with a gas impermeable liner and a reinforcing layer in composite material formed externally around the impermeable liner, as well as a boss coupled to the impermeable liner and to the reinforcing layer to form an opening of the vessel
15 connectable to an external duct, wherein between the impermeable liner and the boss a polymeric sealing mass is arranged which is bound to both the impermeable liner and to the boss by means of in situ cross-linking of the sealing mass.

20 [0010] The cross-linked polymer sealing mass creates a stable, impermeable and permanent bond with the non-metallic impermeable liner and with the metal boss.

[0011] According to one aspect of the invention, the cross-linked sealing mass is an elastomer able to adapt
25 to and to compensate possible deformations of the

impermeable liner.

[0012] In addition, one or more O-rings placed between the boss and a valve screwed into the boss are in direct contact with a metal sealing surface of the boss.

5 [0013] This way it is possible to simply and efficiently obviate the risk of slipping ("creep") phenomena of the surfaces engaged by the seals and to achieve levels of reliability of type 1 pressure vessels (steel).

[0014] For a clearer understanding of the invention and
10 its advantages some of its embodiments, made by way of non-limiting examples will be described below with reference to the drawings, wherein:

[0015] figures 1a, b, c and d illustrate the creep phenomenon in a coupling between the impermeable liner
15 and the boss in a gas cylinder of the prior art;

[0016] figures 2a, b, c and d illustrate the creep phenomenon in a further prior solution of coupling between the impermeable liner and the boss in a gas cylinder;

20 [0017] figure 3 is a cross-section view of a detail of a pressure vessel according to the invention;

[0018] figure 4 is a magnified view of a coupling area boss-impermeable liner of the vessel in figure 3;

[0019] figure 5 is a magnified view of a coupling area
25 boss-impermeable liner of the pressure vessel according

to a further embodiment;

[0020] figure 6 is a magnified view of a detail of the impermeable liner at the boss of a pressure vessel according to one embodiment;

5 [0021] figure 7 is a perspective view of a portion of a boss of a pressure vessel according to one embodiment.

[0022] With reference to figures 3 to 7, a pressure vessel 1 has a gas-impermeable liner 2 (usually the innermost layer of the wall 3 of the vessel 1) and a reinforcing layer 4 in composite material formed externally around
10 the impermeable liner 2, as well as at least one boss 5 coupled to the impermeable liner 2 and to the reinforcing layer 4 to obtain an opening 6 of the pressure vessel 1, connectable to an external duct (not
15 shown), wherein between the impermeable liner 2 and the boss 5 a polymeric sealing mass 7 is arranged which is bound to both the impermeable liner 2 and to the boss 5 by means of in situ cross-linking of the sealing mass 7.

[0023] The cross-linked polymer sealing mass 7 creates a
20 stable and permanent impermeable bond with the non-metal impermeable liner 2 and with the metal boss 5.

[0024] In one embodiment, the sealing mass 7 is an elastomer suitable to adapt to and compensate, within certain limits, possible deformations of the impermeable
25 liner 2.

[0025] In addition, the impermeable liner 2 and the sealing mass 7 are spaced by a valve sealing interface 8 between one or more O-rings 9 of a valve 10 screwed into the boss 5, and the boss 5 itself, so that one or more sealing rings 9 of the valve 10 are in direct contact with a metal sealing surface 11 of the boss 5.

[0026] This way it is possible to simply and efficiently obviate the risk of slipping ("creep") phenomena of the surfaces engaged by the seals 9 and achieve levels of reliability of type 1 pressure vessels (steel).

[0027] In one embodiment, the adhesion of the polymer sealing mass cross-linked in situ 7 is further improved by the presence of a first auxiliary adhesive 13 in an interface 12 between the impermeable liner 2 and the sealing mass 7. One example of an auxiliary adhesive 13 is resorcinol formaldehyde latex (RFL) which in the example of a polyamide impermeable liner 2 (PA6 or PA66) creates a strong chemical bond with the amide.

[0028] Similarly a second auxiliary adhesive 14 may be provided for in an interface 14 between the sealing mass 7 and the boss 5.

[0029] In one embodiment, the entire sealing mass 7 consists of a mixture of resorcinol formaldehyde latex-based precursors (RFL) so that the cross-linking process in situ makes the elastomer (latex) permanently adhere

to the metal boss and fixes the chemical bonds with the impermeable liner 2 in a stable and irreversible manner.

[0030] In one embodiment, the boss 5 comprises a central tubular portion 15 which forms a passage for the pressurised fluid through the opening 6 of the vessel and forms a threaded seat 16 for screwing the valve 10 to the aforesaid metal sealing surface 11 (internal surface of the tubular portion 15) preferably smooth and cylindrical or smooth and frustoconical, against which one or more sealing rings 9 of the valve 10 abut. A coupling flange 17 projects from the tubular portion 15, for example in the shape of a single or double annular disc, forming a seat for the connection of the boss 5 to the impermeable liner 2 (figures 3, 4). The boss 5 composed of the tubular portion 15 and the coupling flange 17 may be made in one piece (Figure 4), for example, by chip removal machining, forging, moulding or a combination of these machining and forming operations, or in several initially separate pieces subsequently assembled together (Figure 5).

[0031] In one embodiment, the coupling flange 17 forms two (not necessarily circular), preferably substantially parallel, annular discs 18, 19, which form between them an annular slot or groove 20 open radially towards the outside of the boss 5. The annular slot 20 receives a

corresponding free edge 21 or collar of the impermeable liner 2 by the interposition of the sealing mass 7. In its final configuration, after the in-situ cross-linking, the sealing mass 7 can form a ring housed in the annular slot 20 of the coupling flange 17 and having in transversal cross-section (radial in relation to the boss) a U-shape which embraces the free edge 21 of the impermeable liner 2. Both the collar 21 of the impermeable liner 2 and the sealing mass 7 are arranged inside the annular slot 20 of the coupling flange.

[0032] In one embodiment (Figure 5) an inner annular disc 18 of the coupling flange 17 is formed in one piece with the tubular portion 15, and an outer annular disc 19 can be screwed on an outer thread of the tubular portion 15 with a possibility of adjusting the axial distance between the two annular discs 18, 19. This facilitates the assembly of the impermeable liner 2 and the boss 5 before the formation of the sealing mass 7 and allows an adaptation of the boss 5 to impermeable liners 2 having different thicknesses.

[0033] The inner annular disc 18 and the free edge 21 of the impermeable liner 2 may have an elliptical or generally elongated and complementary shape, to allow the insertion of the boss 5 in the opening 6 of the impermeable liner 2 and its shape-locking by rotation

for example of 90° (figures 6, 7).

[0034] To provide a reliable and repeatable positioning reference, the outer annular disc 19 of the coupling flange 17 may have at least one positioning protrusion 22, for example circular and concentric with the longitudinal axis of the tubular portion 15, suitable to be inserted in a corresponding positioning recess 23, for example a circular groove, made in an outer surface 24 of the impermeable liner 2 (Figures 5, 7).

[0035] In one embodiment, the collar or free edge 21 of the impermeable liner 2 has one or more recesses or through holes 25 in the contact zone with the sealing mass 7, so that the penetration of the sealing mass 7 in the recesses and/or in the through holes 25 and the subsequent cross-linking of the sealing mass 7 form an additional structural coupling between the elastomeric sealing mass 7 and the impermeable liner 2 (Figures 5, 6).

[0036] The boss 5, in particular the outer annular disc 19, of the coupling flange 17 may form one or more injection holes 26 extending from the outside of the boss 5 up to the space intended to be filled by the sealing mass 7. Said injection holes 26 facilitate the insertion of the not yet cross-linked precursor of the sealing mass 7 and form an additional mechanical

coupling after the in situ cross-linking of the sealing mass 7.

[0037] The sealing mass 7 is preferably a rubber, for example a silicone or latex rubber or other elastomer which is injectable or spreadable in the form of a single component precursor or mixture of multicomponent precursors, and cross-linkable (vulcanisable) for example by a heat treatment (heating).

[0038] Both the sealing mass 7 and the auxiliary adhesive 13 may comprise:

[0039] - latex containing at least one resorcinol-formaldehyde resin and chlorosulfonated polyethylene, or

[0040] - latex comprising a resorcinol-formaldehyde resin with or without vinylpyridine and/or hydrogenated acrylonitrile butadiene rubber (HNBR), or

[0041] - latex comprising at least one resorcinol-formaldehyde-vinylpyridine resin and a acrylonitrile-butadiene rubber (NBR), or

[0042] - latex comprising at least one resorcinol-formaldehyde resin and a chlorosulfonated polyethylene resin.

[0043] The impermeable liner 2 in synthetic material may for example be made of polyamide (PA6 or PA66), polyethylene (PE), high-density polyethylene (HDPE), polypropylene (PP), acrylonitrile butadiene styrene

(ABS), or similar.

[0044] The impermeable liner 2 may be attached to the reinforcing layer 4 by means of:

[0045] -blow moulding into a mould composed of the reinforcing layer 4 with one or more possible intermediate layers and/or

[0046] -moulding of the impermeable liner 2 (for example, using a mould that is different from the reinforcing layer 4) and subsequent wrapping of the reinforcing layer 4 around the impermeable liner 2.

[0047] The reinforcing layer 4 has the function of resisting the internal pressure exerted by the stored fluid and may be manufactured by winding filaments of continuous carbon fibres impregnated with epoxy resin on the impermeable liner or layer 2 previously made, or on a mandrel which is subsequently removed.

[0048] The reinforcing fibres of the reinforcing layer 4 have a tensile strength of over 4500 MPa, preferably from 4800 MPa to 5200 MPa and a modulus of elasticity of over 200 GPa, preferably from 200 to 250 GPa.

[0049] Advantageously, the reinforcing layer 4 comprises a (volumetric) content of reinforcing fibres in the range from 50%vol to 70%vol, preferably from 55%vol to 65%vol, more preferably around 60%vol, where the rest of the volume is composed of the matrix which may be an epoxy

resin or vinyl ester made to harden by heat treatment, e.g. heating to about 120° for about five hours.

[0050] Around the reinforcing layer 4 a further outer protection layer 27 may be made, for example a layer of
5 paint or a shock-proof layer.

[0051] The boss 5 is made of metallic material, e.g. steel.

[0052] In order to improve the adherence of the sealing mass 7 to the impermeable liner 2 it may be opportune to
10 treat the impermeable liner 2 before applying the sealing mass 7 using a plasma surface activation process.

[0053] To such purpose, a plasma is generated, i.e. a super-ionised gas or electrically neutral medium
15 composed of positive and negative particles and neutrals (atoms, molecules and radicals), capable of reacting even with only lightly polarized plastic materials with a very low surface energy. The term "ionised" refers to the presence of free electrons which are not bound to an
20 atom or molecule. The plasma is created by subjecting a gas to a high energy discharge. The gas decomposes into electrons, ions, highly reactive free radicals, shortwave UV light photons and other energised particles. The free radicals and other particles in the
25 highly active plasma can bind to the surface of the

impermeable liner 2 of plastic material, resulting in the formation of additional polar groups that have improved chemical attraction for the elastomeric sealing mass 7.

5 [0054] The metal surface of the boss 5 can be treated, before application of the sealing mass 7, by sanding or pickling and/or by applying a layer of adhesion primer.

[0055] After the mechanical assembly of the boss 5 with the impermeable liner 2, the precursor of the sealing
10 mass 7 is spread or injected into the coupling area between the boss 5 and the impermeable liner 2, for example via injection holes 26 made in the coupling flange 17 of the boss 5.

[0056] After the injection of the precursor of the sealing
15 mass 7, it is subjected to a cross-linking process, for example by heating. This can be done by heating the metal parts of the boss 5, for example, by using electrical resistors or electrical induction.

[0057] The pressure vessel 1 thus manufactured and
20 configured can be used for example as a gas cylinder or as a pressure accumulator.

[0058] Obviously, a person skilled in the art may make further modifications and variations to the pressure vessel 1 and to the manufacturing method according to
25 the present invention so as to satisfy contingent and

specific requirements while remaining within the sphere of protection of the invention as defined by the following claims.

5

10

15

20

25

CLAIMS

1. A pressure vessel (1) with a gas-impermeable liner (2) and a reinforcing layer (4) in composite material formed externally around the impermeable liner (2), as well as at least one boss (5) coupled to the impermeable liner (2) and to the reinforcing layer (4) to obtain an opening (6) of the pressure vessel (1), characterized in that a polymeric sealing mass (7) is arranged between the impermeable liner (2) and the boss (5), said polymeric sealing mass (7) being bound to both the impermeable liner (2) and the boss (5) by in situ cross-linking of the sealing mass (7).
2. The pressure vessel (1) according to claim 1, wherein the impermeable liner (2) is non-metallic, the boss (5) is metallic and the sealing mass (7) is an elastomeric rubber.
3. The pressure vessel (1) according to claim 1 or 2, wherein the impermeable liner (2) and the sealing mass (7) are spaced apart by a valve sealing interface (8) between at least one O-ring gasket (9) of a valve (10) screwed in the boss (5) and the boss (5) itself, said O-ring gasket (9) being in direct contact with a metal sealing surface (11) of the boss (5).
4. The pressure vessel (1) according to one of the

preceding claims, comprising a first auxiliary adhesive (13) in an interface (12) between the impermeable liner (2) and the sealing mass (7).

5 5. The pressure vessel (1) according to one of the preceding claims, comprising a second auxiliary adhesive (14) in an interface (14) between the sealing mass (7) and the boss (5).

6. The pressure vessel (1) according to one of the preceding claims, wherein:

10 - the boss (5) comprises a tubular central portion (15) with a threaded seat (16) for screwing a valve (10), and a coupling flange (17) projecting from the tubular portion (15) and forming two annular discs (18, 19) which define therebetween an annular slot (20) which is
15 open radially outwardly with respect to a longitudinal axis of the boss (5),

- the annular slot (20) receives a corresponding free edge (21) of the impermeable liner (2) by the interposition of the sealing mass (7),

20 - the sealing mass (7) forms a ring received in the annular slot (20) and having in cross-section a U shape enclosing the free edge (21) of the impermeable liner (2),

- both the free edge (21) of the impermeable liner (2)
25 and the sealing mass (7) are arranged inside the annular

slot (20).

7. The pressure vessel (1) according to claim 6, wherein an inner annular disc (18) of the coupling flange (17) is formed as a single piece with the tubular portion (15), and an outer annular disc (19) can be screwed on an outer thread of the tubular portion (15) with a possibility of adjusting the axial distance between the two annular discs (18, 19).

8. The pressure vessel (1) according to claim 7, wherein the inner annular disc (18) and the free edge (21) of the opening (6) of the impermeable liner (2) have an elliptic or generally elongated and complementary shape, so as to allow the insertion of the boss (5) into the opening (6) of the impermeable liner (2) and blocking of the boss by rotation with respect to the impermeable liner (2).

9. The pressure vessel (1) according to claim 7, wherein the outer annular disc (19) of the coupling flange (17) forms at least one positioning protrusion (22), which is preferably circular and concentric with the longitudinal axis of the tubular portion (15), which inserts in a corresponding positioning recess (23), preferably a circular groove, formed in an outer surface (24) of the impermeable liner (2).

10. The pressure vessel (1) according to one of the

preceding claims, wherein the impermeable liner (2) has one or more through holes (25) in the contact area with the sealing mass (7), and sections of the sealing mass (7) extending into the through holes (25) make an additional structural coupling between the sealing mass (7) and the impermeable liner (2).

11. The pressure vessel (1) according to one of the preceding claims, wherein the boss (5) forms one or more injection holes (26) extending from the outside of the boss (5) up to the space taken by the sealing mass (7).

12. The pressure vessel (1) according to one of the preceding claims, wherein:

A) the sealing mass (7) is selected from the group consisting in rubber, silicone rubber, latex, elastomer, injectable or spreadable in the form of monocomponent precursor or mixture of multicomponent precursors and cross-linkable by a thermal treatment, and

B) the impermeable liner (2) is made of a synthetic material chosen from the group consisting in polyamide, polyethylene, high-density polyethylene, polypropylene, acrylonitrile butadiene styrene, and

- the reinforcing layer (4) comprises a wrapping of filament of continuous carbon or glass fibers, impregnated with an epoxy resin, and

- the boss (5) is made of steel.

13. The pressure vessel (1) according to one of the preceding claims, wherein the sealing mass (7) or the auxiliary adhesive (13) are selected from the group consisting in:

- 5 - latex containing at least one resorcinol-formaldehyde resin and chlorosulfonated polyethylene,
- latex comprising a resorcinol-formaldehyde resin with or without vinylpyridine and/or hydrogenated acrylonitrile butadiene rubber (HNBR),
10 - latex comprising at least one resorcinol-formaldehyde-vinylpyridine resin and a acrylonitrile-butadiene rubber (NBR),
- latex comprising at least one resorcinol-formaldehyde resin and a chlorosulfonated polyethylene resin.
- 15 14. A method for manufacturing a pressure vessel (1) according to one of the preceding claims, comprising:
- manufacturing the impermeable liner (2) and manufacturing the boss (5),
- assembling the boss (5) with the impermeable liner
20 (2), arranging a hollow space in a coupling region between the boss (5) and the impermeable liner (2),
- spreading or injecting a precursor of the sealing mass (7) in the hollow space provided, and
- subsequently, subjecting the precursor of the sealing
25 mass (7) to a cross-linking process to bind the sealing

mass to both the boss (5) and the impermeable liner (2).

15. The method according to claim 14, wherein the cross-linking process comprises heating metal parts of the boss (5).

5 16. The method according to claim 14 or 15, comprising treating the impermeable liner (2) before applying the sealing mass (7) by a plasma surface activation process.

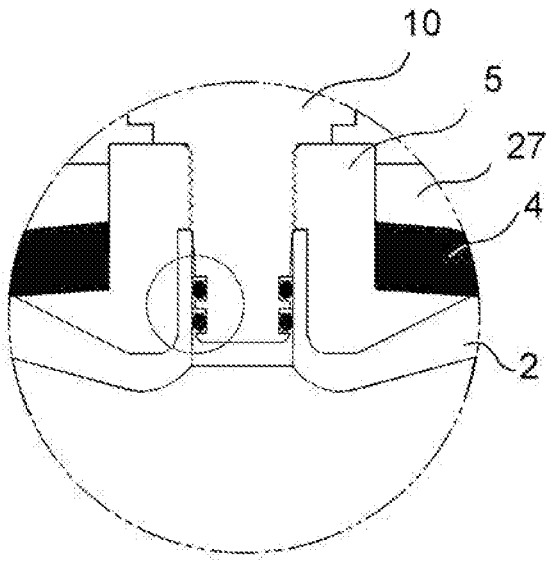

FIG. 1a

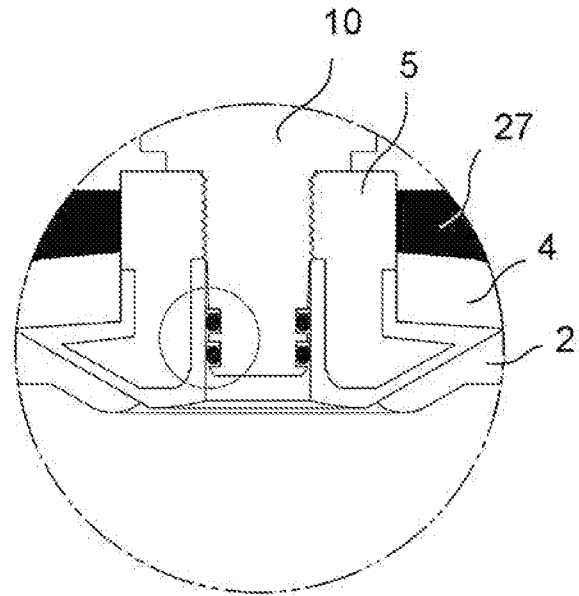

FIG. 2a

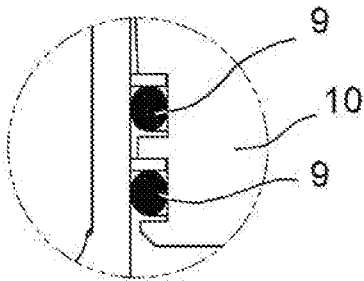

FIG. 1b

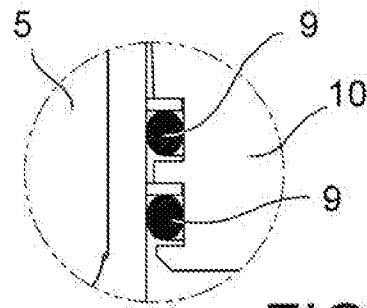

FIG. 2b

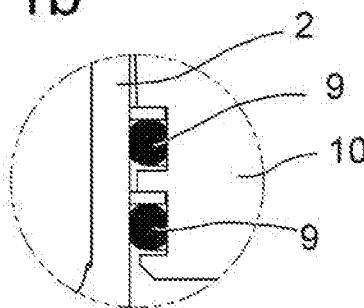

FIG. 1c

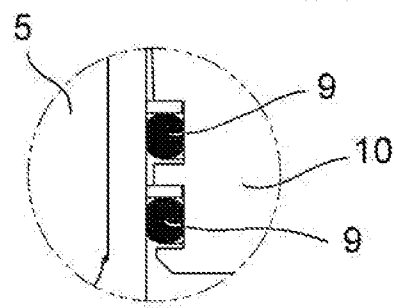

FIG. 2c

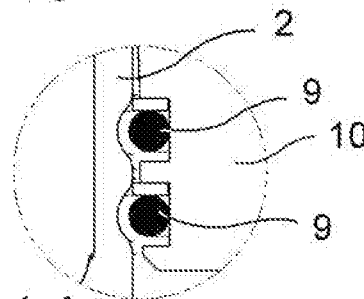

FIG. 1d

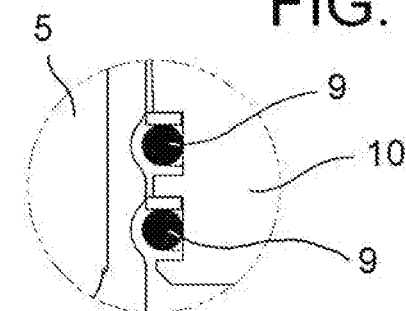

FIG. 2d

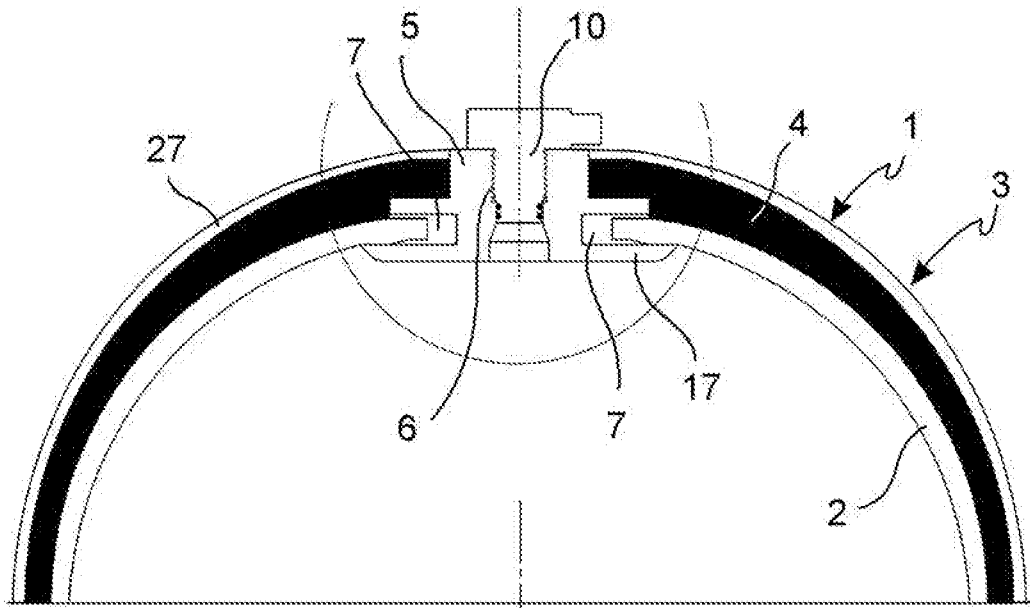

FIG. 3

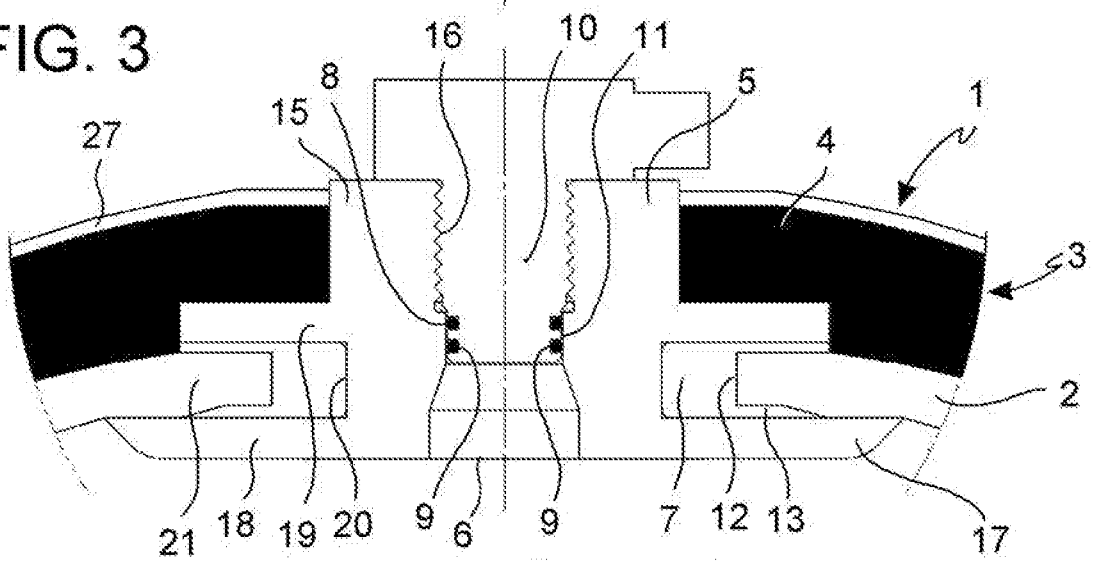

FIG. 4

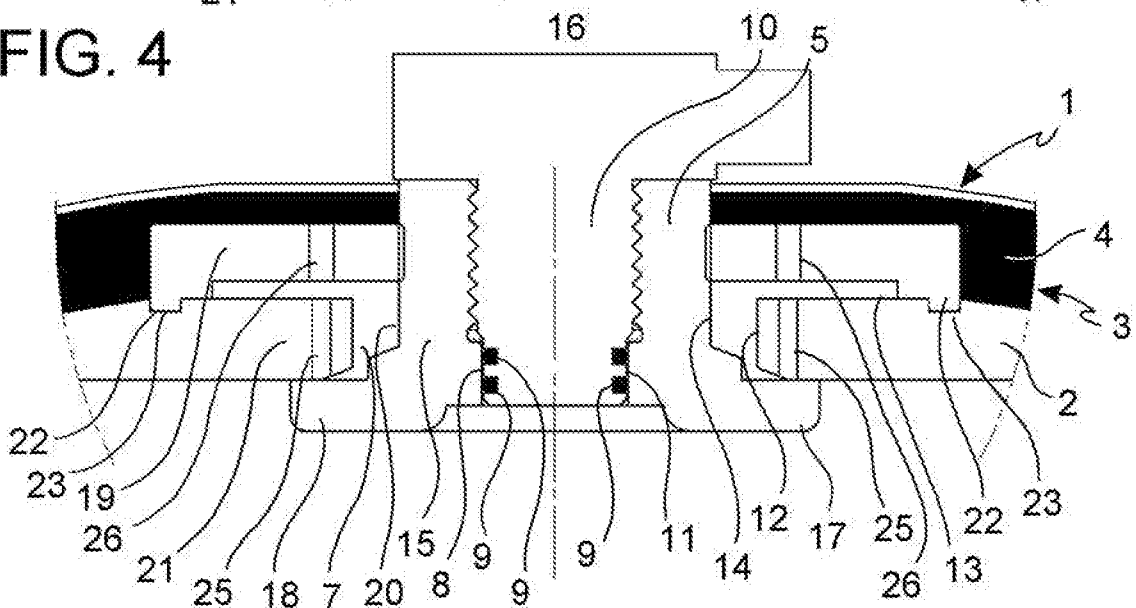

FIG. 5

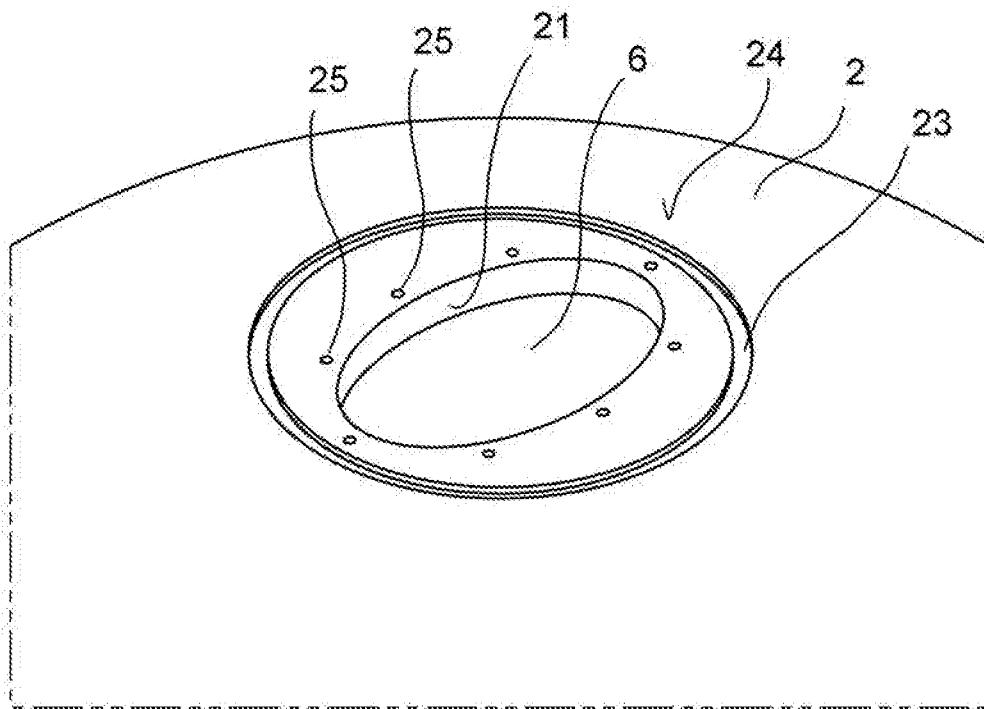

FIG. 6

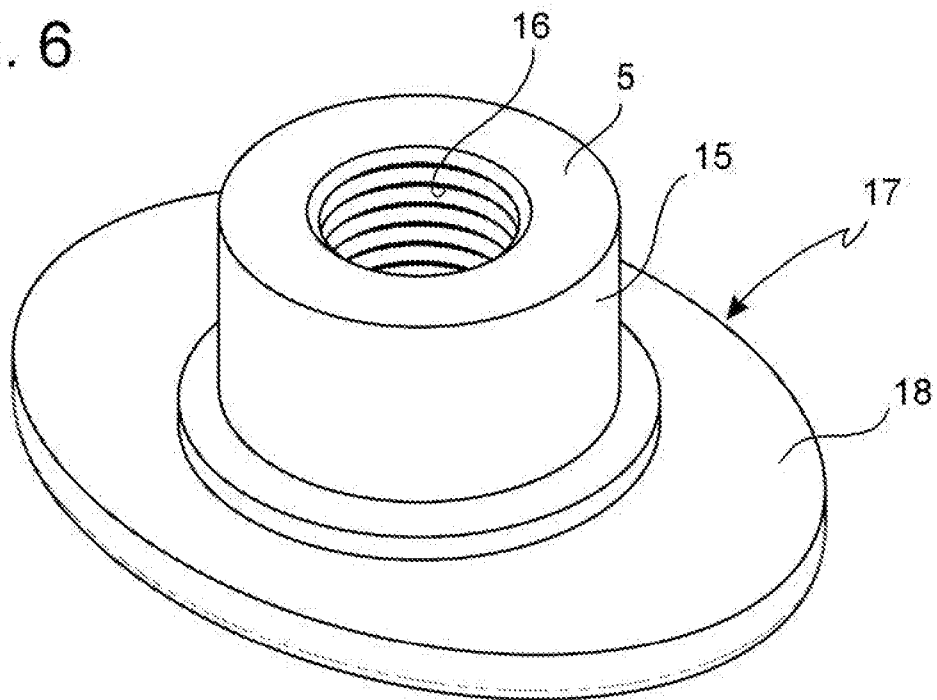

FIG. 7

INTERNATIONAL SEARCH REPORT

International application No
PCT/IB2015/054540

A. CLASSIFICATION OF SUBJECT MATTER
INV. F17C1/06 F17C1/16
ADD.

According to International Patent Classification (IPC) or to both national classification and IPC

B. FIELDS SEARCHED

Minimum documentation searched (classification system followed by classification symbols)
F17C

Documentation searched other than minimum documentation to the extent that such documents are included in the fields searched

Electronic data base consulted during the international search (name of data base and, where practicable, search terms used)

EPO-Internal, WPI Data

C. DOCUMENTS CONSIDERED TO BE RELEVANT

Category*	Citation of document, with indication, where appropriate, of the relevant passages	Relevant to claim No.
X A	WO 2014/014049 A1 (MITSUBISHI RAYON CO [JP]) 23 January 2014 (2014-01-23) paragraphs [0029] - [0045]; figures 1-3,6-10	1-5, 11-13 6-10, 14-16
X	----- WO 2011/152732 A1 (RAGASCO AS [NO]; ULEKLEIV RUNE [NO]; HAMNVIK PER VIDAR [NO]) 8 December 2011 (2011-12-08) pages 4-10; figures 1-5	1-5, 11-13
X	----- US 5 429 845 A (NEWHOUSE NORMAN L [US] ET AL) 4 July 1995 (1995-07-04) columns 4,5; figure 3	1-5, 11-13
X	----- US 3 843 010 A (MORSE W ET AL) 22 October 1974 (1974-10-22) columns 4,5; figures 1-3	1-5, 11-13

Further documents are listed in the continuation of Box C. See patent family annex.

* Special categories of cited documents :

<p>"A" document defining the general state of the art which is not considered to be of particular relevance</p> <p>"E" earlier application or patent but published on or after the international filing date</p> <p>"L" document which may throw doubts on priority claim(s) or which is cited to establish the publication date of another citation or other special reason (as specified)</p> <p>"O" document referring to an oral disclosure, use, exhibition or other means</p> <p>"P" document published prior to the international filing date but later than the priority date claimed</p>	<p>"T" later document published after the international filing date or priority date and not in conflict with the application but cited to understand the principle or theory underlying the invention</p> <p>"X" document of particular relevance; the claimed invention cannot be considered novel or cannot be considered to involve an inventive step when the document is taken alone</p> <p>"Y" document of particular relevance; the claimed invention cannot be considered to involve an inventive step when the document is combined with one or more other such documents, such combination being obvious to a person skilled in the art</p> <p>"&" document member of the same patent family</p>
---	---

Date of the actual completion of the international search 10 September 2015	Date of mailing of the international search report 22/09/2015
--	--

Name and mailing address of the ISA/ European Patent Office, P.B. 5818 Patentlaan 2 NL - 2280 HV Rijswijk Tel. (+31-70) 340-2040, Fax: (+31-70) 340-3016	Authorized officer Nicol, Boris
--	--

INTERNATIONAL SEARCH REPORT

Information on patent family members

International application No

PCT/IB2015/054540

Patent document cited in search report	Publication date	Patent family member(s)	Publication date
WO 2014014049	A1	23-01-2014	
		EP 2876351 A1	27-05-2015
		JP 2015017709 A	29-01-2015
		US 2015167893 A1	18-06-2015
		WO 2014014049 A1	23-01-2014

WO 2011152732	A1	08-12-2011	NONE

US 5429845	A	04-07-1995	NONE

US 3843010	A	22-10-1974	NONE
