

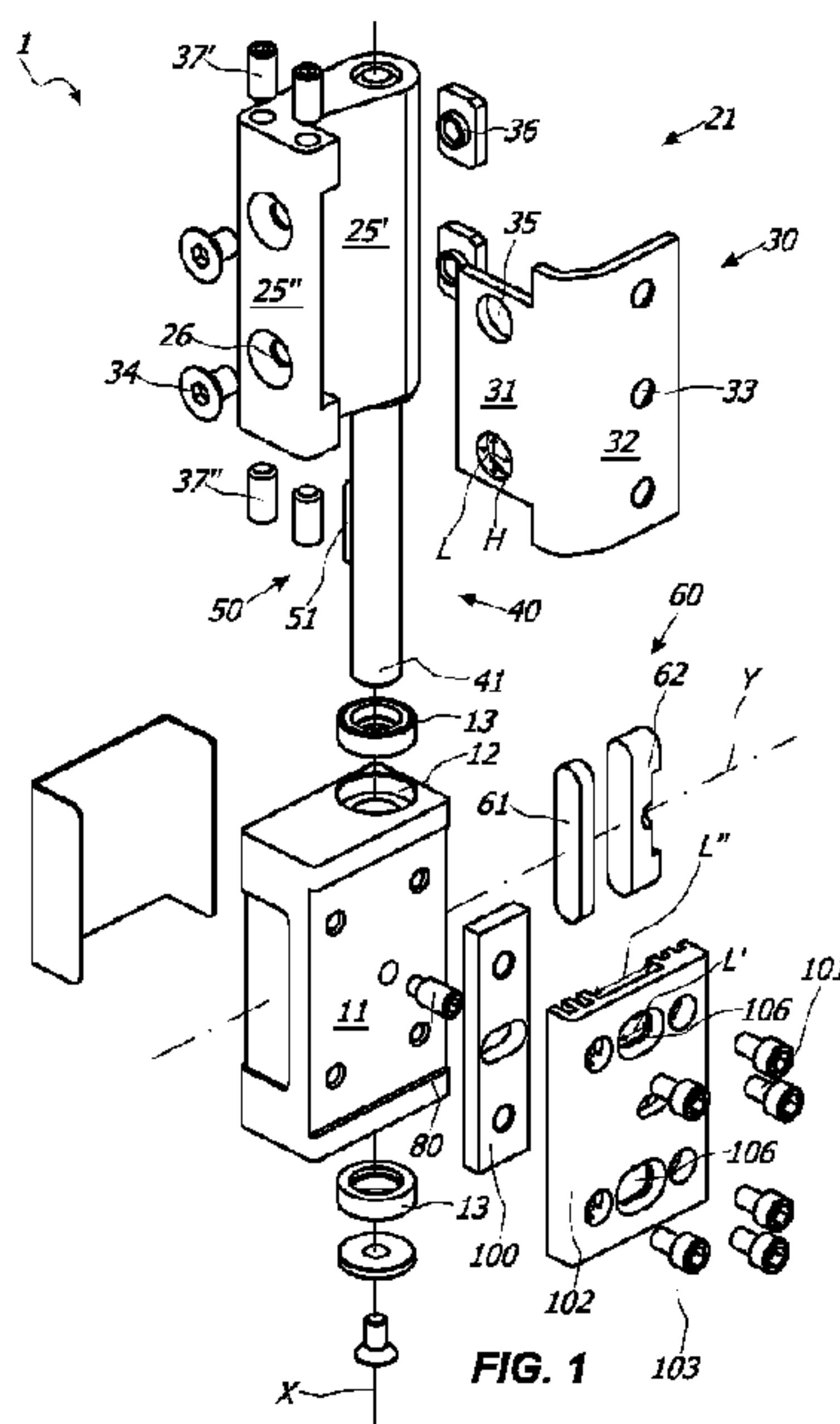

(86) **Date de dépôt PCT/PCT Filing Date:** 2014/04/11
 (87) **Date publication PCT/PCT Publication Date:** 2014/10/16
 (85) **Entrée phase nationale/National Entry:** 2015/09/28
 (86) **N° demande PCT/PCT Application No.:** IB 2014/060661
 (87) **N° publication PCT/PCT Publication No.:** 2014/167546
 (30) **Priorités/Priorities:** 2013/04/12 (ITVI2013A000106);
 2013/04/12 (ITVI2013A000101)

(51) **Cl.Int./Int.Cl.** *E05D 5/06* (2006.01),
E05D 11/06 (2006.01), *E05D 11/10* (2006.01),
E05D 5/12 (2006.01), *E05D 7/04* (2006.01)
 (71) **Demandeur/Applicant:**
 IN & TEC S.R.L., IT
 (72) **Inventeur/Inventor:**
 BACCHETTI, LUCIANO, IT
 (74) **Agent:** INTEGRAL IP

(54) **Titre : CHARNIERE POUVANT ETRE CACHEE POUR LE MOUVEMENT DE ROTATION REGULE D'UNE PORTE, EN PARTICULIER D'UNE PORTE RENFORCEE**
 (54) **Title: CONCEALABLE HINGE FOR THE CONTROLLED ROTATABLE MOVEMENT OF A DOOR, IN PARTICULAR A REINFORCED DOOR**



(57) **Abrégé/Abstract:**

An Anuba concealed hinge for rotatable moving a door (D), in particular a reinforced door, connected to a tubular support structure (F, CF) which includes a rear counterframe (CF) anchored to a wall (W) or a similar support and a front frame (F) anchored to the counterframe (CF), the hinge comprising a lower fixed half-hinge (10) and an upper movable half-hinge (20) rotatably coupled each other for rotating about a first longitudinal axis (X) between an open position and a closed position. The lower fixed half-hinge (10) includes a box-shaped hinge body (11) to be concealedly inserted within the tubular support structure (F, CF), the upper movable half-hinge (20) including a connecting plate (21) connected to the door (D) to extend from the tubular support structure (F, CF) in the open position and to concealedly retract within the tubular support structure (F, CF) in the closed position. The movable half-hinge (20) includes a pivot (40) defining said first axis (X) unitary connected to the connecting plate (21), the hinge body (11) including a seat (12) internally housing said pivot (40).

(12) INTERNATIONAL APPLICATION PUBLISHED UNDER THE PATENT COOPERATION TREATY (PCT)

(19) World Intellectual Property
Organization
International Bureau(43) International Publication Date
16 October 2014 (16.10.2014)

WIPO | PCT

(10) International Publication Number
WO 2014/167546 A3

(51) International Patent Classification:

E05D 5/06 (2006.01) E05D 11/10 (2006.01)
E05D 7/04 (2006.01) E05D 5/12 (2006.01)
E05D 11/06 (2006.01)

(21) International Application Number:

PCT/IB2014/060661

(22) International Filing Date:

11 April 2014 (11.04.2014)

(25) Filing Language:

Italian

(26) Publication Language:

English

(30) Priority Data:

VI2013A000101 12 April 2013 (12.04.2013) IT
VI2013A000106 12 April 2013 (12.04.2013) IT

(71) Applicant: IN & TEC S.R.L. [IT/IT]; Via Guglielmo Oberdan 1/a, I-25128 Brescia (IT).

(72) Inventor: BACCHETTI, Luciano; Via Della Fonte, 9/c, I-25075 Nave (bs) (IT).

(74) Agents: AUTUORI, Angelo et al.; Borgo Santa Lucia, 31, I-36100 Vicenza (VI) (IT).

(81) Designated States (unless otherwise indicated, for every kind of national protection available): AE, AG, AL, AM, AO, AT, AU, AZ, BA, BB, BG, BH, BN, BR, BW, BY, BZ, CA, CH, CL, CN, CO, CR, CU, CZ, DE, DK, DM, DO, DZ, EC, EE, EG, ES, FI, GB, GD, GE, GH, GM, GT, HN, HR, HU, ID, IL, IN, IR, IS, JP, KE, KG, KN, KP, KR, KZ, LA, LC, LK, LR, LS, LT, LU, LY, MA, MD, ME, MG, MK, MN, MW, MX, MY, MZ, NA, NG, NI, NO, NZ, OM, PA, PE, PG, PH, PL, PT, QA, RO, RS, RU, RW, SA, SC, SD, SE, SG, SK, SL, SM, ST, SV, SY, TH, TJ, TM, TN, TR, TT, TZ, UA, UG, US, UZ, VC, VN, ZA, ZM, ZW.

(84) Designated States (unless otherwise indicated, for every kind of regional protection available): ARIPO (BW, GH, GM, KE, LR, LS, MW, MZ, NA, RW, SD, SL, SZ, TZ, UG, ZM, ZW), Eurasian (AM, AZ, BY, KG, KZ, RU, TJ, TM), European (AL, AT, BE, BG, CH, CY, CZ, DE, DK, EE, ES, FI, FR, GB, GR, HR, HU, IE, IS, IT, LT, LU, LV, MC, MK, MT, NL, NO, PL, PT, RO, RS, SE, SI, SK, SM,

[Continued on next page]

(54) Title: CONCEALABLE HINGE FOR THE CONTROLLED ROTATABLE MOVEMENT OF A DOOR, IN PARTICULAR A REINFORCED DOOR

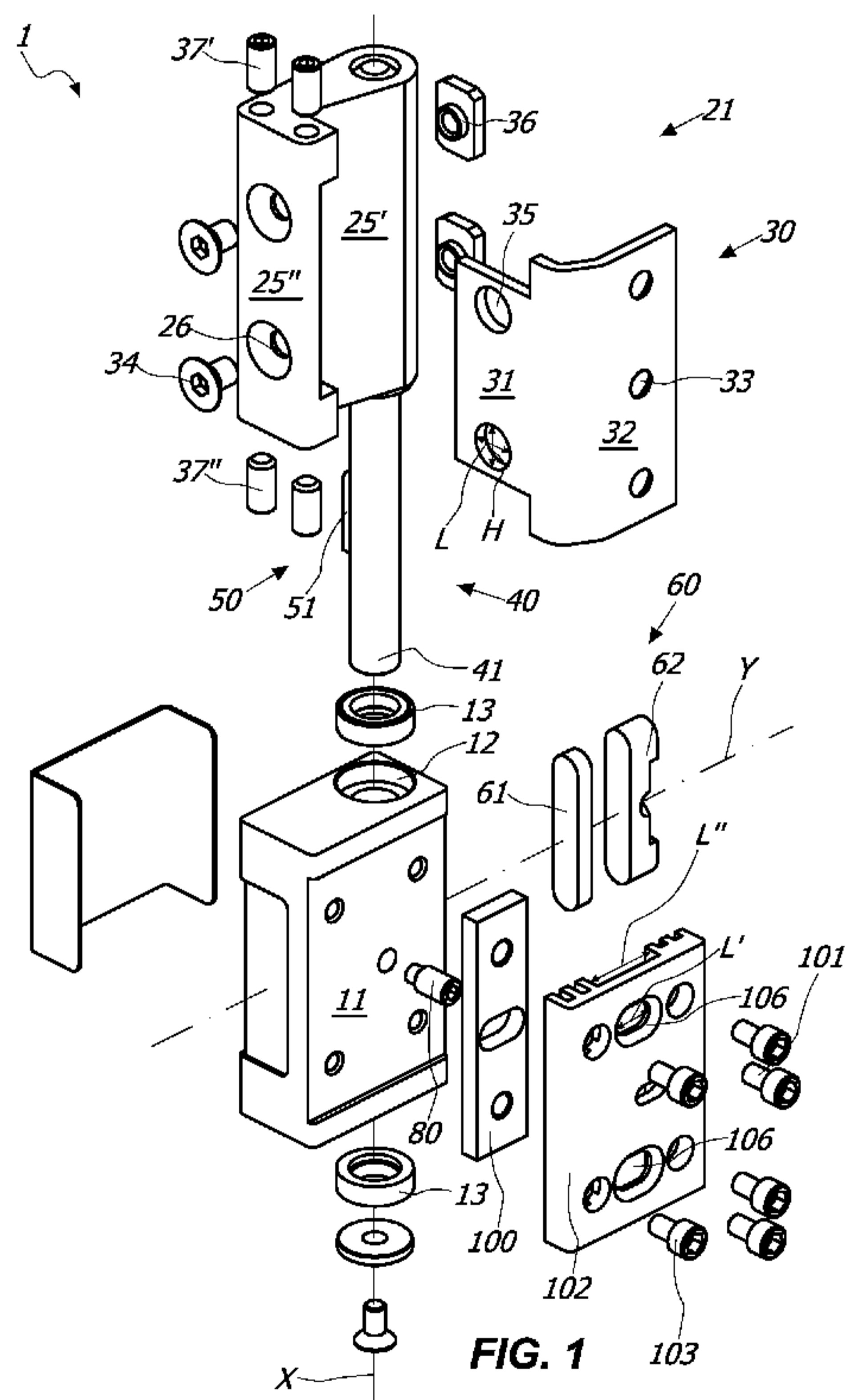

(57) Abstract: An Anuba concealed hinge for rotatable moving a door (D), in particular a reinforced door, connected to a tubular support structure (F, CF) which includes a rear counterframe (CF) anchored to a wall (W) or a similar support and a front frame (F) anchored to the counterframe (CF), the hinge comprising a lower fixed half-hinge (10) and an upper movable half-hinge (20) rotatably coupled each other for rotating about a first longitudinal axis (X) between an open position and a closed position. The lower fixed half-hinge (10) includes a box-shaped hinge body (11) to be concealedly inserted within the tubular support structure (F, CF), the upper movable half-hinge (20) including a connecting plate (21) connected to the door (D) to extend from the tubular support structure (F, CF) in the open position and to concealedly retract within the tubular support structure (F, CF) in the closed position. The movable half-hinge (20) includes a pivot (40) defining said first axis (X) unitary connected to the connecting plate (21), the hinge body (11) including a seat (12) internally housing said pivot (40).

WO 2014/167546 A3



TR), OAPI (BF, BJ, CF, CG, CI, CM, GA, GN, GQ, GW, (88) **Date of publication of the international search report:**
KM, ML, MR, NE, SN, TD, TG). 12 March 2015

Published:

— *with international search report (Art. 21(3))*

CONCEALED HINGE FOR THE CONTROLLED ROTATABLE MOVEMENT OF A DOOR, IN PARTICULAR A REINFORCED DOOR**DESCRIPTION**Field of invention

5 The present invention is generally applicable to the technical field of the closing or damping/control hinges, and particularly relates to a hinge for the controlled rotatable movement of a door, in particular but not exclusively a reinforced door.

Background of the invention

10 As known, the closing or damping hinges generally comprise a movable element, usually fixed to a door, a shutter or the like, which movable element is pivoted on a fixed element, usually fixed to a support frame, or to a wall and/or the floor.

 More particularly, in the case of concealed hinges for reinforced doors or the like, the fixed element of the hinge is inserted into a support structure that includes a rear tubular counterframe anchored to a wall or like support and a front frame anchored to the counterframe.

15 On the other hand, the movable element generally includes a connecting plate to be fixed to the door intended to come out from the tubular support structure in the open position and to retract completely within the tubular support structure in the closed position.

 Generally, such hinges are purely mechanical, and not allow any kind of adjustment of the opening angle of the door or anyway no control of the movement of the door.

20 Examples of such known hinges are shown in the documents US5075928 and WO2010049860.

 The absence of control makes such hinges extremely dangerous, since due to the great weight of the reinforced door there is the danger of unhinging of the door or the inflection of the tubular support structure to which the hinge is anchored.

25 Similarly, due to the great weight of the door, the hinge tends to lose the initial position and/or to misalign.

 Moreover, the adjustment of the position of the door is difficult and complicated. Furtherly, to do this operation at least two operators are needed.

30 Another recognized drawback of these hinges is in the high frictions between fixed and movable element, which leads to frequent wear and breakage, with consequent need for continuing maintenance.

Summary of the invention

 An object of the present invention is to overcome at least partly the above mentioned drawbacks, by providing a hinge having high performances, simple construction and low cost.

Another object of the invention is to provide a hinge which allows controlling the movement of the door upon its opening and/or its closing.

Another object of the invention is to provide a strong and reliable hinge.

Another object of the invention is to provide a hinge having extremely small dimensions.

5 Another object of the invention is to provide a hinge suitable for supporting very heavy doors and shutters.

Another object of the invention is to provide a hinge that has a minimum number of constituent parts.

10 Another object of the invention is to provide a hinge suitable to maintain the exact closing position during time.

Another object of the invention is to provide a hinge that is safe.

Another object of the invention is to provide a hinge that is easy to install.

Another object of the invention is to provide a hinge that simplifies the operations of maintenance and/or replacement thereof.

15 Another object of the invention is to provide a hinge which allows a simple adjustment of the door to which it is connected.

These objects, as well as other which will appear clearer hereafter, are fulfilled by a hinge having one or more of the features herein disclosed, claimed and/or shown.

20 Advantageous embodiments of the invention are defined in accordance with the dependent claims.

Brief description of the drawings

Further features and advantages of the invention will appear more evident upon reading the detailed description of some preferred, non-exclusive embodiments of a hinge **1**, which is described as non-limiting examples with the help of the annexed drawings, in which:

25 **FIGS. 1** is an exploded view of an embodiment of the hinge **1**;

FIGS. 2a and **2b** are perspective views of the embodiment of the hinge **1** of FIG. 1 respectively in the closed and open position;

30 **FIGS. 3a** and **3b** are respectively perspective and upper views of the embodiment of the hinge **1** of FIG 1 in which the movable element **20** is mounted on a door **D** and the fixed element **10** is mounted on a frame **F**, the door **D** being in the closed position;

FIGS. 3c and **3d** are respectively perspective and upper views of the embodiment of the hinge **1** of FIG 1 in which the movable element **20** is mounted on a door **D** and the fixed element **10** is mounted on a frame **F**, the door **D** being in the open position;

FIG. 4 is a schematic view of the assembly pivot **40** - cam **51** - interface element **62** - elastic

counteracting element **61** to be used in the embodiment of the hinge **1** of FIG. 1;

FIGS. 5 and **6** are respectively side views of a first embodiment of the interface element **62** and the pivot **40** to be used in the embodiment of the hinge **1** of FIG. 1;

FIGS. 7a and **7b** are side views of a second embodiment of the pivot **40** to be used in the
5 embodiment of the hinge **1** of FIG. 1;

FIG. 7c is a side view of a second embodiment of the interface element **62** to be used in the embodiment of the hinge **1** of FIG. 1;

FIGS. 8a, 8b and **8c** are respective top view and views sectioned along a plane *VIIIb* – *VIIIb* and along a plane *VIIIc* - *VIIIc* of the embodiment of the hinge **1** of FIG. 1, the hinge being in the
10 closed position;

FIG. 9 is an enlarged view of some details of FIG. 8b, with in **FIG. 9a** an exploded view of such details;

FIG. 10 is an enlarged view of further details of FIG. 8b, with in **FIG. 10a** an exploded view of such details;

FIG. 11 is an exploded perspective view of a further embodiment of the hinge **1**, in which the box-shaped hinge body **11** is integral with the backplate **102**;

FIG. 12 is a perspective view of the hinge body **11** of the embodiment of the hinge **1** of FIG. 11;

FIGS. 13a and **13b** are respectively perspective and sectional partly cut views of some details
20 of a further embodiment of the cam means **50** and the follower means **60**;

FIGS. 14 to **19** are sectional views of the cam means **50** and follower means **60** of FIGS. 13a and 13b in various operational steps, in which for each step the relative position of the cam means **50**, the pushing member **68'** and the elastic counteracting element **61** is enlargedly shown.

Detailed description of some preferred embodiments

25 With reference to the above figures, the hinge according to the invention, generally indicated **1**, is particularly useful for the rotatable possibly controlled movement during opening and/or closing of a closing element **D**, such as a reinforced door, which may be anchored to a stationary support structure, such as a wall, a floor or a ceiling.

30 Suitably, the hinge **1** may be concealedly inserted in a tubular support structure, which may be formed in a *per se* known manner by a rear counterframe **CF**, which can be anchored to the wall **W** or like support, and by a front frame **F** anchored to the counterframe **CF**.

In particular, the hinge **1** can be configured as a concealed "Anuba" hinge anchored to the frame **F** by the plate **P₂**.

Advantageously, the hinge **1** is concealedly insertable in the support structure formed by the

tubular rear counterframe **CF** and the front frame **F**.

Conveniently, the hinge **1** may include a fixed element **10** to be fixed to the stationary support **W**, for example by the frame **F** or the counterframe **CF**, on which a movable element **20** is pivoted to rotate about a longitudinal axis **X**, which may be substantially vertical, between an open position and a closed position.

In particular, the hinge **1** may include, respectively may consist of, a lower fixed half-hinge **10** and a movable upper half-hinge **20** rotatably coupled each other to rotate between the open and closed positions about the axis **X**.

Advantageously, the lower fixed half-hinge **10** may include a box-shaped hinge body **11** anchored to the stationary support **W**, while the movable upper half-hinge **20** may include means **21** for fixing to the door **D**.

Suitably, the hinge body **11** may be concealedly insertable within the support structure formed by the tubular rear counterframe **CF** and the front frame **F**, while the connecting means **21** may be defined by a connecting plate susceptible to extend from the tubular support structure in the open position of the door **D**, as shown for example in FIGS. 3c and 3d, and to retract within the same tubular support structure in the closed position of the door **D**, as shown for example in FIGS. 3a and 3b.

In particular, the connecting plate **21** of the hinge **1** may be rotatably connected to the body **11** by means of the hinge pivot **40**, which will be better described later.

Advantageously, the box-shaped hinge body **11** may include a passing-through seat **12** defining the axis **X** within which is inserted with minimal clearance the pivot **40**, which may be unitary connected to the connecting plate **21**.

In this way, the pivot **40** is unitary movable with the door **D** between the open and closed positions. Thanks to this feature, the hinge **1** is able to support even very heavy doors **D** without misalignments or changing of the behaviour.

Suitably, at the ends of the passing-through seat **12** of the box-shaped body **11** respective anti-friction elements **13** may be placed, such as bearings. This allows the movable element **20** to rotate about the axis **X** with minimum friction, so that the hinge **1** is able to support even very heavy doors **D**.

The hinge body **11** may internally include a working chamber **14** defining a second axis **Y** which is substantially perpendicular to the first axis **X** defined by the passing-through seat **12** for the pivot **40**.

Suitably, the pivot **40** may include cam means **50** rotating around the axis **X**, while the working chamber **14** may include follower means **60** interacting with the former to slidably move

along the axis **Y** between a first and a second end-stroke position, corresponding for example to the open and closed door **D** position.

The follower means **60** may include an elastic counteracting element susceptible to elastically oppose the pushing force imparted by the cam means. As non-limiting example, the elastic counteracting element may include, respectively may consist of, a spring, a nitrogen cylinder or a portion of polymeric material.

In a preferred but not exclusive embodiment of the hinge **1**, the elastic counteracting element may consist of an elastomer body **61**, which may be plate-shaped, disk-shaped or cylindrical-shaped.

Advantageously, the elastomer body **61** may be made of a polyurethane elastomer of the compact type, for example Vulkollan[®]. Suitably, the elastomer may have a Shore A hardness of 50 ShA to 95 ShA, preferably of 70 ShA to 90 ShA. More preferably, the elastomer body **61** may have a Shore A hardness of 80 ShA.

The use of the elastomer in place of the classic spring allows to have a very high braking force, in a very small space. In fact, the stroke of the elastomer body **61** along the axis **Y** may be of some millimeters, for example 2-4 mm.

Moreover, the elastomer body **61** allows to obtain a braking effect of great efficiency in a purely mechanical hinge without the use of oil or like hydraulic damping means, for example during the opening.

In fact, upon the opening of the door **D** the elastic counteracting element **61** passes from the first to the second end-stroke position and remains in this position until the closing of the door by a user, so that the hinge **1** is a control hinge braked during opening.

Moreover, the follower means **60** may advantageously include an interface element **62** having a first end **63'** which interacts with the elastic counteracting element **61** and a second end **63''** interacts with the cam means **50**.

Advantageously, the interface element **62** may have a substantially "C"- shape with a central elongated portion **64** defining a third longitudinal axis **Z** substantially parallel to the axis **X** and perpendicular to the axis **Y** and a pair of end transverse appendices **65'**, **65''** substantially perpendicular to the axis **X** and parallel to the axis **Y**.

Both the elongated central portion **64** and the end transverse appendices **65'**, **65''** may include respective operating surfaces **66**, **67'**, **67''** placed at the front end **63''**, the function of which is better explained later.

Moreover, the pivot **40** may suitably include the cam means **50**, so that the latter rotate unitary with the former around the axis **X**. Advantageously, the cam means **50** may include one or

more cam elements susceptible to interact with the follower means **60**.

More particularly, in the pivot **40** of FIGs. 4 and 6 the cam means **50** may include a single cam element, while in the pivot **40** of FIGs. 7a and 7b the cam means **50** may include two cam elements.

For example, the single cam element may be defined by a plate-shaped body **51** insertable
5 transversely in a removable manner within a seat **42** of the pivot **40** so that a portion of the former extends from the latter. This configuration simplifies the assembly of the hinge **1**.

On the other hand, the plate-shaped body **51** may be integrated into the pivot **40** in an unremovable manner.

Suitably, the plate-shaped body **51** may have a front peripheral edge **53** susceptible to
10 interact with the interface element **62**, for example in correspondence of the operating surface **66**. To this end, the front peripheral edge **53** may be appropriately rounded.

In this way, the interface element **62** progressively compresses the elastomer body **61** upon the opening of the door **D**. The elastomer body **61** may further be susceptible to remain in the configuration elastically deformed until the closing of the door **D** by a user. In other words, the hinge
15 **1** is elastically braking upon opening.

Suitably the hinge **1** may be configured so that the cam element **51** interacts with the operating surface **66** after an angular rotation of the door **D**, for example 45°. Following interaction with the interface element **62**, the cam element **51** compresses the elastomer body **61**, so that the hinge is mechanically braked upon opening during the subsequent angular rotation, for example the
20 next 45°. In other words, the first angular rotation is free, that is not braked, while the subsequent angular rotation is braked by the braking action of the elastomer body **61**.

In one preferred but not exclusive embodiment, two cam elements may be provided, in particular a pair of first cam elements **52'**, **52''** susceptible to interact with the operating surfaces **67'**, **67''** of the interface element **62** and a second cam element consisting of the plate-shaped element
25 **51** which is susceptible to interact with the operating surface **66**.

The first cam elements **52'**, **52''** may be defined by a pair of substantially flat faces formed on the outer surface **44** of the pivot **40**, in longitudinally staggered positions so as to be operatively in contact with the operating planar surfaces **67'**, **67''** of the interface element **62**.

Conveniently, the cam means **50** and the follower means **60** may be configured so that the
30 substantially flat faces **52'**, **52''** and the operative surfaces **67'**, **67''** are substantially parallel and in mutual contact when the door **D** is in the closed position, as shown for example in FIGS 11a to 11d, and are substantially perpendicular and spaced apart each other when the door **D** is in the open position, as shown for example in FIGS 13a to 13d.

The plate-shaped element **51** may further define a plane π substantially perpendicular to the

substantially planar faces **52'**, **52''**.

In this way, it is possible to achieve a full control on the door **D** upon the opening, throughout all the angular rotation thereof.

In fact, for a first portion of angular rotation the substantially flat faces **52'**, **52''** and the operative surfaces **67'**, **67''** interact with each other to partially compress the elastomeric body **61**, thus urging it from the rest or starting stroke position to an intermediate compressed position. Further, for the next portion of the angular rotation of the door **D** the plate-shaped element **51** and the operating surface **66** of the interface element **62** interact each other so as to further compress the elastomeric body **61**, thus compressing it from the intermediate compressed position to the totally compressed or end stroke position.

This allows to progressively compress the elastic element, so as to obtain a braking effect for the entire angular rotation of the door **D**.

In another preferred but not exclusive embodiment, shown for example in the FIGs. 13a to 19, the interface element **62** may be configured as a pushing member **68'** and include a protrusion **300**, having a generally hemispherical shape. On the other hand, the cam means **50** may include a plurality of seats **310**, **320**, **330** each corresponding to a supper position of the door.

More in particular, the seats **310**, **320**, **330** is able to receive the protrusion **300** to supper the door in the supper positions.

Suitably, the seat **310** may correspond to the closed door position, while the seats **320**, **330** may correspond to the open door positions. Advantageously, the latter may be mutually opposite with respect to the closed door position.

In a preferred but not exclusive embodiment, the seat **310** corresponding to the closed door position may have a generally "V"-shape with two consecutive planes **311**, **312** angled each other with predetermined angle.

In this way, as particularly shown in FIG. 15, the sliding of the hemispherical protrusion **300** on the planes **311**, **312** upon the rotation of the door is simplified, so as to ensure the automatic closing of the door starting from a predetermined angle, for example 20°.

At the same time, the user can rotate the door from the closed door position in both opening directions.

To maximize this effect, the angle between the planes **311**, **312** may be at least 90°, preferably at least 110°. In a preferred but not exclusive embodiment, the angle between the planes **311**, **312** may be 120°.

Moreover, each of the seats **320**, **330** corresponding to the open door positions may advantageously have two consecutive portions **321**, **322**; **331**, **332** having different shape.

The first portions **322; 332** may be generally flat, while the second portions **321; 331** may be countershaped with respect to the shape of the protrusion **300**, and in particular may be hemispherical.

5 In this way, the first flat portions **322; 332** may promote the sliding of the projection **310** thereon to convey it towards the second portions **321; 331**, suitable to support the door.

In this way, as particularly shown in FIG. 16, the automatic opening of the door starting from a predetermined angle, for example 70°, is ensured.

10 As particularly shown in FIG. 17, the first flat portions **322; 332** act as pilot members for the second hemispherical portions **321; 331**, so that the insertion of the protrusion **300** in the latter takes place without noise.

Advantageously, the first flat portions **322; 332** may be substantially perpendicular to the planes **312, 311**.

Moreover, thanks to the above configuration the door may be rotated from the support position only in one direction. In other words, the rotation in the other direction is prevented.

15 Indeed, as particularly shown in FIG. 19, if a user attempts to further rotate the door, the momentum caused by the elastic counteracting element **61** opposes this force, which momentum urges the one against the other the protrusion **300** and the second portions **321; 331**.

20 Suitably, the elastic counteracting element **61** may be configured so as to allow a further slight rotation of the door after the support position in the door open position. To this end, the elastic counteracting element **61** after this minimum rotation can reach the position of maximum compression.

This absorbs the shock undergone by the door upon the reaching of the support position. This configuration is particularly advantageous in the case of glass door, which in the case of abrupt shock could be damaged or broken.

25 The embodiment of the cam means **50** and the follower means **60** shown in FIGs. 13a to 19 and described above is particularly advantageous with the above described elastic counteracting element **61** made of elastomer.

In fact, in the latter a minimum stroke corresponds to a very high strength.

30 Therefore, suitably precompressing the elastic counteracting element **61** in the working chamber **14** the strength of the hinge **1** is maximized.

Also, the elastic counteracting element **61** made of elastomer maximizes the effect of stopping the rotation, as described above.

In one preferred but not exclusive embodiment, it is possible to adjust the opening angle of the door **D**.

For the purpose, an adjusting screw **80** may be provided transversely inserted in the hinge body **11** with a first operating end **81** accessible by a user to adjust the penetration of the former **80** through the corresponding wall of the latter **11** and an opposite end **82** susceptible to come into contact with the plate-shaped element **51**.

5 By appropriately acting on the operating end **81** of the screw **80** the opening angle of the door can be adjusted in a simple and rapid manner, so as to avoid any impact of the door **D** against the stationary support **W**.

The hinge **1** is extremely effective and performing, and is also greatly simple to assemble.

10 For example, the hinge body **11** may have, in addition to the passing-through seat **12** for containing the pivot **40**, a passing-through opening **16** to make accessible the working chamber **14** from the outside.

In particular, the passing-through opening **16** may be susceptible to allow the insertion within the working chamber **14** of both the follower means **60** and the cam means **50**, in particular of the plate-shaped element **51**.

15 The passing-through opening **16** defines an axis **Y'** perpendicular to both the axis **Y** and the axis **X**.

In practice, both the cam means **50** and the follower means **60** may be removably inserted in the working chamber **14** by sliding along the axis **Y'**.

20 This is particularly advantageous if it is necessary to change the elastic element **61**, for example to insert a softer or harder one in order to vary the braking action of the hinge **1**, or to change the plate-shaped element **51**, for example to insert one of different configuration to vary the braking action of the hinge **1**.

25 In fact, in order to mount the cam means **50** and the follower means **60**, it is simply needed to insert within the working chamber **14** through the passing-through opening **16** the elastic counteracting element **61** and the interface element **62**, subsequently to insert the pivot **40** into the seat **12** and then rotate the latter to move the seat **42** thereof in correspondence of the same passing-through opening **16**, so as to allow the insertion of the plate-shaped element **51**. The dismounting thereof may occur in the reverse order.

30 The hinge **1**, in addition to the above mentioned features and advantages, is particularly advantageous because it is possible to adjust the position of the door **D** in the three dimensions, that is both in height and in a plane substantially parallel to the floor as shown for example in FIG. 3c.

In fact, the connecting plate **21** may include a first portion **25'** susceptible to receive the pivot **40** and a second portion **25''** susceptible to receive the mounting bracket **30** and to allow the adjustment along the directions **d**, **d'**, as shown in FIG. 2b.

Suitably, the mounting bracket **30** may have a first plate portion **31** operatively fixable to the first portion **25'** of the mounting body **24** monolithically coupled with a second plate portion **32**, connectable in turn to the door **D** by means of suitable screws insertable into the holes **33**.

5 The operational connection between the first portion **25'** of the mounting body **24** and the first plate portion **31** of the mounting bracket **30** may be made by means of suitable screws **34** inserted through the holes **26** of the mounting body **24** and the openings **35** of the mounting bracket **30** and lockable in suitable locking elements **36**.

10 By suitably operating on the screws **34** it is possible to move the mounting bracket **30**, and then the door **D**, along the direction **d'**. In fact, by appropriately unscrewing the screws **34** it is possible to move the mounting bracket **30** for a stroke equal to the length **L** of the openings **35** in which the screws **34** are inserted.

15 The movement along the vertical direction **d** is ensured by the screws **37'**, **37''** inserted through the second portion **25''** of the connecting plate **21**, the first plate portion **31** of the mounting bracket **30** lying therebetween. As mentioned above, the latter is secured to the former by using the screws **34**.

The screws **37'**, **37''** can be operated by unscrewing the screws **34**, that allow the movement of the mounting bracket **30** with a stroke equal to the height **H** of the openings **35** in which the screws **34** are inserted.

20 To enable movement of the hinge **1** along the direction **d''**, the hinge body **11** may be movably mounted on an anchor plate **100**, which may be anchored to the tubular support structure **F**, **CF** by using the screws **101**.

To this end, a backplate **102** may be provided, which may be coupled to the hinge body **11** by means of screws **103** to define an interspace **104** therebetween, in which interspace the anchor plate **100** is housed. The interspace **104** may include two side abutment surfaces **105'**, **105''**.

25 In the alternative embodiment shown in FIGS. 11 and 12, the backplate **102** may be integrated into the hinge body **11**, i.e. the two parts can be made in a single piece. This allows to provide a more economic hinge **1**.

The screws **101** are engageable in the anchor plate **100** by passing through the slots **106** of the backplate **102**.

30 By appropriately acting on the screws **101** it is possible to move the assembly of the hinge body **11** and the backplate **102**, and then the door **D**, along the direction **d''**. In fact, by suitably unscrewing the screws **101**, it is possible to move the assembly between the hinge body **11** and the backplate **102**, and hence the hinge **1**, for a stroke equal to the length **L'** of the slots **106** in which the screws **101** are inserted and/or the distance between the side abutment surfaces **105'**, **105''** of the

interspace **104**.

The hinge **1** may further be designed to minimize friction between the fixed half-hinge **10** and the movable half-hinge **20**.

For this purpose, the upper end **110'** of the seat **12** may include a respective upper annular housing **111'** suitable to receive a respective upper antifriction element **13'**, such as a bearing.

As particularly shown in FIGS. 17d and 17e, the pivot **40** may include a upper radial expansion **112'**, for example a flange, with an upper operating surface **113'** susceptible to come in contact with the connecting plate **21** and a lower operating surface **113''** susceptible to remain faced to the upper annular housing **111'**.

Advantageously, the upper annular housing **111'** and the upper antifriction element **13'** may be mutually configured so that the lower operating surface **113''** of the upper radial expansion **112'** is susceptible to abut against the upper antifriction element **13'**. In this way, the pivot **40** can rotate onto the upper antifriction element **13'** by remaining mutually spaced from the hinge body **11**.

To this end, the inner diameter D_1 of the upper annular housing **111'** may be substantially equal to the outer diameter D_2 of the upper antifriction element **13'**, while the height h_2 of the latter may be slightly greater than the height h_1 of the former, for example a few tenths of a millimeter.

Furtherly, the lower end **110''** of the seat **12** suitably includes a lower annular housing **111''** susceptible to receive a respective lower antifriction element **13''**.

The lower end **41** of the pivot **40** may include a blind axial hole **114** susceptible to receive a locking screw **115**. A pressure element **112''** may further be provided, for example a washer, susceptible to be interposed between the locking screw **115** and the lower antifriction element **13''** to define a lower radial expansion. Advantageously, the latter may include an upper operative surface **116** susceptible to remain faced to the lower annular housing **111''**.

The latter, the lower antifriction element **13''** and the pivot **40** may be mutually configured so that the upper operative surface **116** of the pressure element **112''** is susceptible to abut against the pivot **40** and to remain spaced apart from the lower antifriction element **13''**.

In this way, the possible reaction forces due to the rotation of the pivot **40** at its lower end **41** is loaded on the lower antifriction element **13''**.

This prevents the slipping of the pivot **40** from the seat **12** and/or the misalignment of the same pivot **40**.

To minimize friction between the lower fixed half-hinge **10** and the upper half-hinge **20**, the inner diameter D_3 of the lower annular housing **111''** may be substantially equal to the outer diameter D_4 of the lower antifriction element **13''**, while the outer diameter D_5 of the pressure element **112''** may be slightly less than the inner diameter D_3 of the lower annular housing **111''**.

Moreover, the height h_3 of the latter may suitably be substantially equal to the sum of the height h_4 of the lower antifriction element **13''** and the height h_5 of the pressure element **112''**.

Advantageously, the upper and lower antifriction elements **13'**, **13''** may consist of bearings of the axial-radial type, in order to suitably load thereon both the axial and the radial stresses due to the weight of the door **D** and/or their reactions forces.

From the above description, it is apparent that the hinge **1** fulfils the intended objects.

The hinge **1** is susceptible to many changes and variants. All particulars may be replaced by other technically equivalent elements, and the materials may be different according to the needs, without exceeding the scope of the invention defined by the appended claims.

10

CLAIMS

1. A concealed hinge for rotatable moving a door (**D**), in particular a reinforced door, connected to a tubular support structure (**F**, **CF**) which includes a rear counterframe (**CF**) anchored to a wall (**W**) or a similar support and a front frame (**F**) anchored to the counterframe (**CF**), the hinge
5 comprising a lower fixed half-hinge (**10**) and an upper movable half-hinge (**20**) rotatably coupled each other for rotating about a first longitudinal axis (**X**) between an open position and a closed position;

wherein said lower fixed half-hinge (**10**) includes a box-shaped hinge body (**11**) to be concealed within the tubular support structure (**F**, **CF**) and anchorable thereto, said upper movable half-hinge (**20**) including a pivot (**40**) defining said first axis (**X**) and a connecting plate (**21**) anchorable
10 to the door (**D**), connecting plate (**21**) being reciprocally connected with said pivot (**40**) to extend from the tubular support structure (**F**, **CF**) in said open position and to concealedly retract within the tubular support structure (**F**, **CF**) in said closed position;

wherein said box-shaped hinge body (**11**) includes a seat (**12**) internally housing said pivot (**40**), the latter including cam means (**50**) rotating about said first longitudinal axis (**X**), said box-shaped hinge body (**11**) further including at least one working chamber (**14**) defining a second longitudinal axis (**Y**) substantially perpendicular to said first axis (**X**), said at least one working chamber (**14**) including follower means (**60**) interacting with said cam means (**50**) for sliding along said second longitudinal axis (**Y**) between a first and a second end-stroke position, said follower means (**60**) including at least one elastic counteracting element (**61**).

2. Hinge according to claim 1, wherein said pivot (**40**) includes at least one elongated appendix (**51**) transversely extending with respect to said first axis (**X**) to rotate within said seat (**12**), said follower means (**60**) including at least one interface element (**62**) having a first end (**63'**) interacting with said at least one elastic counteracting element (**61**) and a second end (**63''**) interacting with said at least one elongated appendix (**51**).

3. Hinge according to claim 2, wherein said elongate appendix (**51**) defines a plane (π) substantially parallel to said first axis (**X**) and substantially perpendicular to said second axis (**Y**).

4. Hinge according to claim 2 or 3, wherein said elongate appendix (**51**) is defined by a plate-shaped element.

5. Hinge according to claim 4, wherein said plate-shaped element (**51**) is removably
30 insertable into a seat (**42**) of said pivot (**40**).

6. Hinge according to claim 5, wherein said box-shaped hinge body (**11**) has at least one passing-through opening (**16**) to allow insertion/removal of said plate-shaped element (**51**) in/from said seat (**42**) of said pivot (**40**) when the latter is mounted within the respective seat (**12**).

7. Hinge according to claim 6, wherein said passing-through opening (**16**) allows the

insertion/removal of both said plate-shaped element (51) in/from said seat (42) and the follower means (60) in/from the working chamber (14).

8. Hinge according to claim 7, wherein said seat (42) of said pivot (40), said working chamber (14) and said at least one passing-through opening (16) are reciprocally configured in such a manner that the mounting of said cam means (50) and said follower means (60) occurs by at first inserting said follower means (60) within said working chamber (14) through said passing-through opening (16), subsequently by inserting the pivot (40) into said seat (12) and then by rotating the latter to move the seat (42) thereof in correspondence of said passing-through opening (16), so as to allow a user to insert said plate-shaped element (51).

9. Hinge according to one or more of the preceding claims, wherein said box-shaped hinge body (11) further comprises at least one abutment screw (80) having a first operating end (82) lying within said seat (12) for abutting against said elongated appendix (51) of said pivot (40) and a second operating end (81) accessible from outside by a user to adjust the penetration of said at least one abutment screw (80) within said seat (12), so as to adjust the opening and/or closing angle of the hinge.

10. Hinge according to claim 9, wherein said at least one abutment screw (80) is transversely inserted within the hinge body (11) with respect to said first axis (X), said elongated appendix (51) defining a plane (π) with at least one side wall (54) susceptible to impact against said first operating end (82) of said at least one abutment screw (80).

11. Hinge according to one or more of the preceding claims, wherein said at least one elastic counteracting element (61) includes, respectively consists of, at least one portion of elastically deformable polymeric material.

12. Hinge according to claim 11, wherein said elastic counteracting element (61) consists of a body made of polymeric material.

13. Hinge according to claim 12, wherein said body of elastically deformable polymeric material has a cylindrical or disk-like or plate-shaped shape.

14. Hinge according to one or more of the preceding claims, wherein said polymeric material consists of an elastomer.

15. Hinge according to claim 14, wherein said elastomer is polyurethane of the compact type.

16. Hinge according to claim 14 or 15, wherein said elastomer has a Shore A hardness of 50 ShA to 95 ShA, preferably of 70 ShA to 90 ShA.

17. Hinge according to one or more of the preceding claims, wherein said cam means (50) are configured to progressively compress said at least one portion of elastically deformable

polymeric material of said at least one elastic counteracting element (61) upon one of the opening or closing of the door (D) or like closing element, said at least one portion of elastically deformable polymeric material of said at least one elastic counteracting element (61) being susceptible to remain in the elastically deformed configuration until a user imparts the other of the opening or closing of the door (D) or like closing element so that the hinge is an elastically braked hinge controlled during opening and/or closing.

18. Hinge according to one or more of the preceding claims, wherein said second end (63") of said interface element (62) includes at least one operating surface (66) interacting with said cam means (50), the latter including at least one first cam element (51) having a front peripheral edge (53) susceptible to interact with said at least one operating surface (66).

19. Hinge according to claim 18, wherein said front peripheral edge (53) of said at least one first cam element (51) is susceptible to progressively press against said operating surface (66) of said at least one interface element (62) so as to urge the first end (63") thereof against the body made of polymeric material (61) for elastically deforming thereof.

20. Hinge according to one or more of the preceding claims, wherein said cam means (50) include at least one first cam element (51) susceptible to interact with said follower means (60) for moving thereof from one of said first and second end stroke position to a third position which is intermediate therebetween and vice-versa, said cam means (50) further including at least one second cam element (52', 52") susceptible to interact with said follower means (60) for moving thereof from said third intermediate position to the other of said first and second end stroke position and vice-versa.

21. Hinge according to claim 20, wherein said at least one first and second cam elements (51; 52', 52") are mutually superimposed along said first axis (X), said follower means (60) including at least one first operating surface (66) and at least one second operating surface (67', 67") which are also mutually superimposed to sequentially interact respectively with said at least one first cam element (51) and with said at least one second cam element (52', 52") and vice-versa.

22. Hinge according to claim 21, wherein said follower means (60) include at least one interface element (62) interposed between said pivot (40) and said at least one elastic counteracting element (61), said at least one interface element (62) comprising said at least one first operating surface (66) and said at least one second operating surface (67', 67").

23. Hinge according to claim 22, wherein said at least one interface element (62) is substantially "C"-shaped with a central elongated portion (64) defining a third longitudinal axis (Z) substantially parallel to said first axis (X) and at least one end transverse appendix (65', 65"), respectively a pair of end transverse appendices (65', 65"), substantially perpendicular to said first

axis (X), said central elongated portion (64) including said at least one first operating surface (66), said at least one end transverse appendix (65', 65''), respectively said end transverse appendices (65', 65''), including said at least one second operating surface (67', 67''), respectively each a respective second operating surface (67', 67'').

5 24. Hinge according to claim 23, wherein said pivot (40) includes a substantially cylindrical outer surface (44) including at least one substantially flat face (52', 52''), respectively a pair of substantially flat faces (52', 52''), defining said at least one second cam element (52', 52'').

10 25. Hinge according to claim 24, wherein said at least one second operating surface (67', 67''), respectively said second operating surfaces (67', 67''), are substantially planar, said cam means (50) and said follower means (60) being configured so that said at least one substantially flat face (52', 52''), respectively said substantially flat faces (52', 52''), and said at least one second operating surface (67', 67''), respectively said second operating surfaces (67', 67''), are substantially parallel and mutually contact engaged when said movable element (20) is in the closed position and are substantially perpendicular to each other and mutually spaced apart when said movable element
15 (20) is in the open position.

26. Hinge according to claim 24 or 25, wherein said elongated appendix (51) transversely extends along said second axis (Y) to define said first cam element (51), said elongated appendix (51) including a peripheral edge (53) susceptible to contact engage the first operating surface (66) of said interface element (62) to progressively interact with said elastic counteracting element (61).

20 27. Hinge according to claim 27, wherein said elongate appendix (51) defines a plane (π) substantially perpendicular to said at least one substantially flat face (52', 52''), respectively to said substantially flat faces (52', 52''), of said second cam element.

25 28. Hinge according to one or more of the preceding claims, wherein said cam means (50) and follower means (60) are configured to interact with each other for a first angular portion of the rotation of said pivot (40) between the open and closed positions and to not interact with each other for a second subsequent angular portion of the rotation thereof and vice-versa.

30 29. Hinge according to claim 28, wherein said first angular portion is subsequent to said second angular portion when said pivot (40) rotates from the closed position to the open position, said first angular portion being previous to said second angular portion when said pivot (40) rotates from the open position to the closed position, in such a manner that the hinge is braked during opening.

30 30. Hinge according to one or more of the preceding claims, wherein one of said cam means (50) and said at least one interface element (62) of said follower means (60) includes at least one projection (300), the other of said cam means (50) and said at least one interface element (62) of

said follower means (60) including at least one seat (310, 320, 330) susceptible to receive said at least one protrusion (300).

31. Hinge according to claim 30, wherein said cam means (50) include a plurality of said projections (300) or seats (310, 320, 330) each corresponding to a supper position of the door, said at least one interface element (62) including a single projection (300) or seat (310, 320, 330) susceptible to cooperate with corresponding seats (310, 320, 330) or protrusions (300) to supper the door in said supper positions.

32. Hinge according to claim 31, wherein the single projection (300) or seat of said at least one interface element (62) has a generally curved shape.

33. Hinge according to claim 31 or 32, wherein said plurality of protrusions (300) or seats (310, 320, 330) of said cam means (50) correspond to the closed door position and at least one open door position.

34. Hinge according to claim 33, wherein the protrusion (300) or seat of said cam means (50) corresponding to one of the closed door position and the at least one open door position has a generally "V"-shape with two consecutive planes (311, 312) angled each other with predetermined angle so as to simplify the sliding thereon of said single curve protrusion (300) or seat of said at least one interface element (62) upon the rotation of the door, so as to ensure the automatic closure or opening of the door from a preset angle and the possibility for the user to rotate the door from the supper position in both directions.

35. Hinge according to claim 33 or 34, wherein the protrusion (300) or seat of said cam means (50) corresponding to the other of the closed door position and the at least one open door position has two consecutive portions (321, 322, 331, 332) having different shape, a first portion (322, 332) which is generally flat so as to simplify the sliding thereon of said single curve protrusion (300) or seat of said at least one interface element (62) and a second (321, 331) generally curved portion which is countershaped with respect to the curved shape of said single protrusion (300) or seat of said at least one interface element (62) to supper the door, so as to ensure the automatic closure or opening of the door from a preset angle and the possibility for the user to rotate the door from the supper position in only one direction, thus preventing the rotation in the other direction.

36. Hinge according to claim 35, wherein the rotation of the door by the user in said other direction is opposed by the momentum caused by said elastic counteracting element (61), which urges the one against the other said single curved protrusion (300) or seat of said at least one interface element (62) and said second countershaped portion (321, 331) of the projection (300) or seat of said cam means (50).

37. Hinge according to claim 35 or 36, wherein said elastic counteracting element (61) is

configured so as to allow a further slight rotation of the door in said other direction to reach the position of maximum compression, so as to absorb the shock undergone by the door upon the reaching of said supper position.

5 38. Hinge according to one or more of the preceding claims, wherein the protrusion (300) or seat of said cam means (50) having a generally "V"- shape corresponds to the closed door position, said cam means (50) including a pair of projections or seats (320, 330) having different shape corresponding to the same open door positions mutually opposite with respect to said closed door position.

10 39. Hinge according to one or more of the preceding claims, wherein the first flat portion (321, 322, 331, 332) of said protusion or seat (320, 330) having different shape is substantially perpendicular to the plane proximal thereto of said two planes (311, 312) of said protusion or seat (310) having a "V"-shape.

15 40. Hinge according to one or more of the preceding claims, wherein said cam means (50) include a plurality of said seats (310, 320, 330), said at least one interface element (62) including said single protrusion (300).

41. Hinge according to one or more of the preceding claims, wherein said single protrusion (300) of said at least one interface element (62) has a hemispherical shape, said second countershaped portion (321, 331) of the seat (320, 330) of said cam means (50) having also a hemispherical shape.

20 42. Hinge according to one or more of the preceding claims, wherein the generally "V"-shaped seat (310) of said cam means (50) has said planes (311, 312) angled at least 90°, preferably of at least 110°.

25 43. Hinge according to claim 1, wherein said seat (12) is defined by a hole passing-through said hinge body (11), the upper end (110') of said seat (12) including a respective upper annular housing (111') susceptible to house a respective upper antifriction element (13'), the lower end (110'') of said seat (12) including a respective lower annular housing (111'') susceptible to house a respective lower antifriction element (13''), said movable half-hinge (20) being rotatably pivoted on said hinge body (11) to rotate onto said upper antifriction element (13') and/or said lower antifriction element (13''), said pivot (40) including a lower radially enlarged member (112'') susceptible to abut
30 against said lower antifriction element (13'') to prevent the slipping of the pivot (40) from said seat (12) and/or to prevent the misalignment of said pivot (40) during use.

44. Hinge according to claim 43, wherein said pivot (40) includes an upper radially enlarged member (112') with an upper operating surface (113') susceptible to abut against said connecting plate (21) and a lower operating surface (113'') susceptible to remain faced to the upper annular

housing (111'), said upper annular housing (111') and upper antifriction element (13') being mutually configured so that the lower operating surface (113'') of said upper radially enlarged member (112') is susceptible to abut against said upper antifriction element (13'), in such a manner that said pivot (40) rotates onto said upper antifriction element (13') remaining mutually spaced apart from said hinge body (11).

45. Hinge according to claim 44, wherein said upper annular housing (111') has a predetermined first inner diameter (D_1) and first height (h_1), said upper antifriction element (13') having a generally annular shape with a predetermined second outer diameter (D_2) and second height (h_2), said first inner diameter (D_1) being substantially equal to said second outer diameter (D_2), said predetermined second height (h_2) being slightly higher than said predetermined first height (h_1) for minimize friction between said fixed lower half-hinge (10) and said upper half-hinge (20).

46. Hinge according to claim 44 or 45, wherein said lower radially enlarged member (112'') comprises an upper operating surface (116) susceptible to remain faced to the lower annular housing (111''), said lower annular housing (111''), pivot (40) and lower antifriction element (13'') being mutually configured so that the upper operating surface (116) of said lower radially enlarged member (112'') is contact engaged with said pivot (40).

47. Hinge according to claim 46, wherein the lower end (41) of said pivot (40) includes an axial blind hole (114) adapted to receive a locking screw (115), a pressure member (112'') interposed between said clamping screw (115) and said lower antifriction element (13'') being provided to define said lower radially enlarged member (112''), and further wherein said locking screw (115), said pressure member (112''), said axial blind hole (114), said lower antifriction element (13'') and said lower annular housing (111'') are configured to pull the pivot (40) and to urge said lower operating surface (113'') of said upper radially enlarged member (112') against said upper antifriction element (13') and said upper operating surface (116) of said lower radially enlarged member (112'') against said lower antifriction element (13'').

48. Hinge according to claim 47, wherein said lower annular housing (111'') has a predetermined third inner diameter (D_3) and third height (h_3), said lower antifriction element (13'') having a generally annular shape with a predetermined fourth outer diameter (D_4) and fourth height (h_4), said pressure member (112'') having a generally annular shape with a predetermined fifth outer diameter (D_5) and fifth height (h_5), said third inner diameter (D_3) being substantially equal to said fourth outer diameter (D_4), said fifth outer diameter (D_5) being slightly less than said third inner diameter (D_3) to minimize friction between said fixed lower half-hinge (10) and said upper movable half-hinge (20).

49. Hinge according to one or more of the preceding claims, wherein said connecting plate

(21) includes a first portion (25') operatively coupled with said pivot (40) and a second portion (25'') designed to receive a mounting bracket (30), the latter including a first plate-like portion (31) movably mounted on the former (25'') to slide along a first direction (d) substantially parallel to said first axis (X) and along a second direction (d') substantially perpendicular to the first direction (d),
 5 said mounting bracket (30) including a second plate-like portion (32) fixable to the door (D) monolithically coupled with said first plate-like portion (31), said lower fixed half-hinge (10) including an anchoring plate (100) anchorable to said tubular support structure (F, CF), said hinge body (11) being movably mounted on said anchoring plate (100) to slide along a third direction (d'') substantially perpendicular to both of said first and second directions (d, d').

10 50. Hinge according to claim 49, wherein said first plate-like portion (31) of said mounting bracket (30) is operatively connected with said second portion (25'') of said connecting plate (21) by at least one first screw (34) insertable through at least one hole (26) passing through said second portion (25'') of said connecting plate (21) and at least one opening (35) passing through said first plate-like portion (31) of said mounting bracket (30) and engageable in at least one corresponding
 15 locking element (36), said first plate-like portion (31) of said mounting bracket (30) remaining interposed between said second portion (25'') of said connecting plate (21) and said at least one locking element (36), said at least one first screw (34) being at least partially disengageable from said at least one locking element (36) for the translational motion of said mounting bracket (30) along said second direction (d') for a stroke corresponding to the length (L) of said at least one opening (35)
 20 of said first plate-like portion (31) of said mounting bracket (30).

25 51. Hinge according to claim 50, wherein said first plate-like portion (31) of said mounting bracket (30) is interposed between at least one upper abutment screw (37') and at least lower abutment screw (37'') insertable through said second portion (25'') of said connecting plate (21), said at least one upper abutment screw (37') and at least one lower abutment screw (37'') being
 operateable by a user for the translational motion of said mounting bracket (30) along said first direction (d) for a stroke corresponding to the height (H) of said at least one opening (35) of said first plate-like portion (31) of said mounting bracket (30) upon the disengagement of said at least one first screw (34) from said at least one locking element (36).

30 52. Hinge according to claim 8, 9 or 10, wherein said hinge body (11) is movably mounted on said anchoring plate (100) by means of a backplate (102), said anchoring plate (100) being movable in an interspace (104) between said hinge body (11) and said backplate (102), said interspace (104) including two lateral abutment surfaces (105', 105''), said anchoring plate (100) being fixable to said tubular support structure (F, CF) by at least one second screw (101) passing through at least one corresponding slot (106) of said backplate (102) engageable in the anchoring

plate (100), said at least one second screw (101) being at least partly disengageable from said anchoring plate (100) to translate said hinge body (11) along said third direction (d'') for a stroke corresponding to the length (L') of said at least one slot (106) of said backplate (102) and/or the distance between said lateral abutment surfaces (105', 105'') of said interspace (104).

5

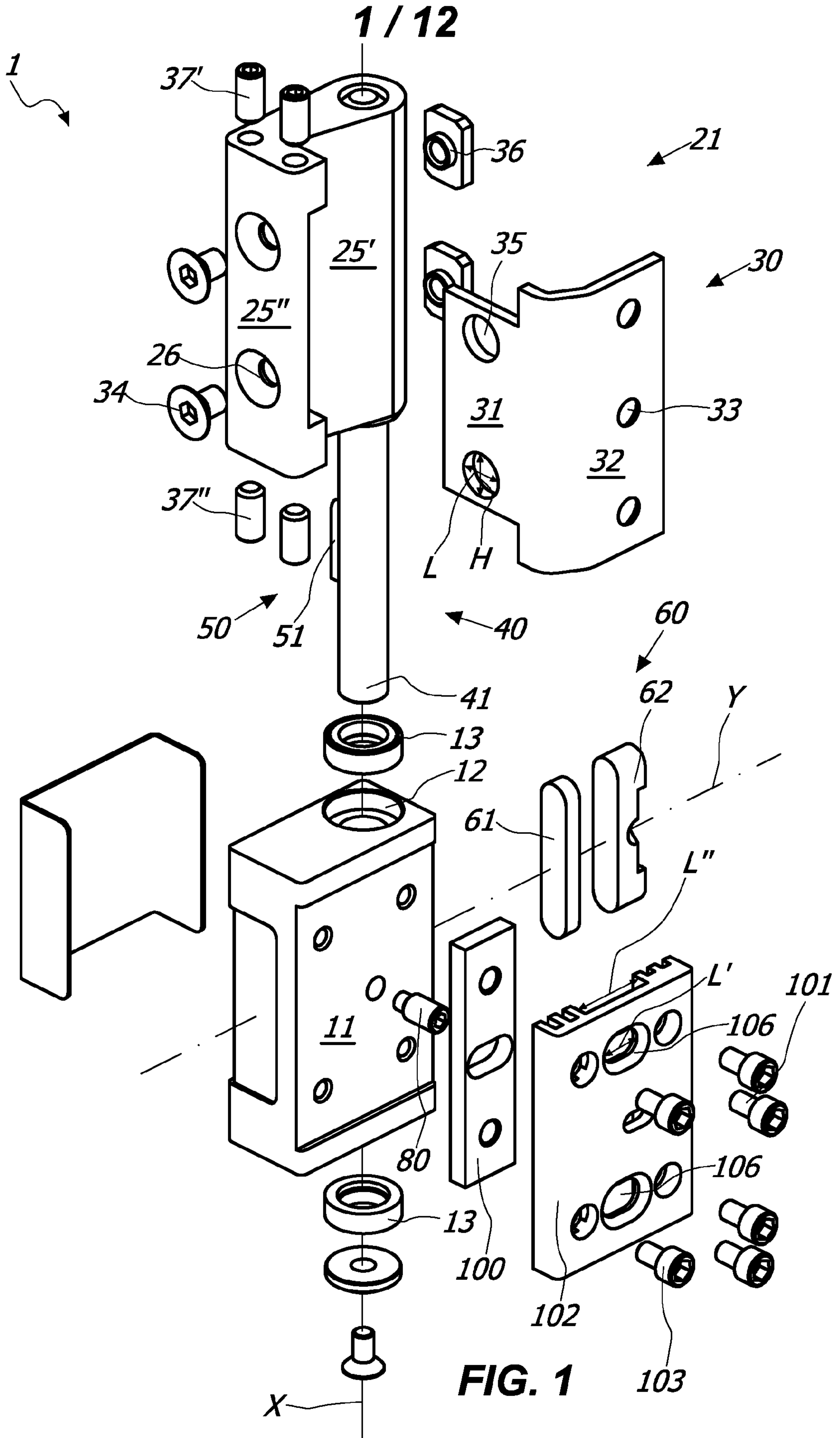

2 / 12

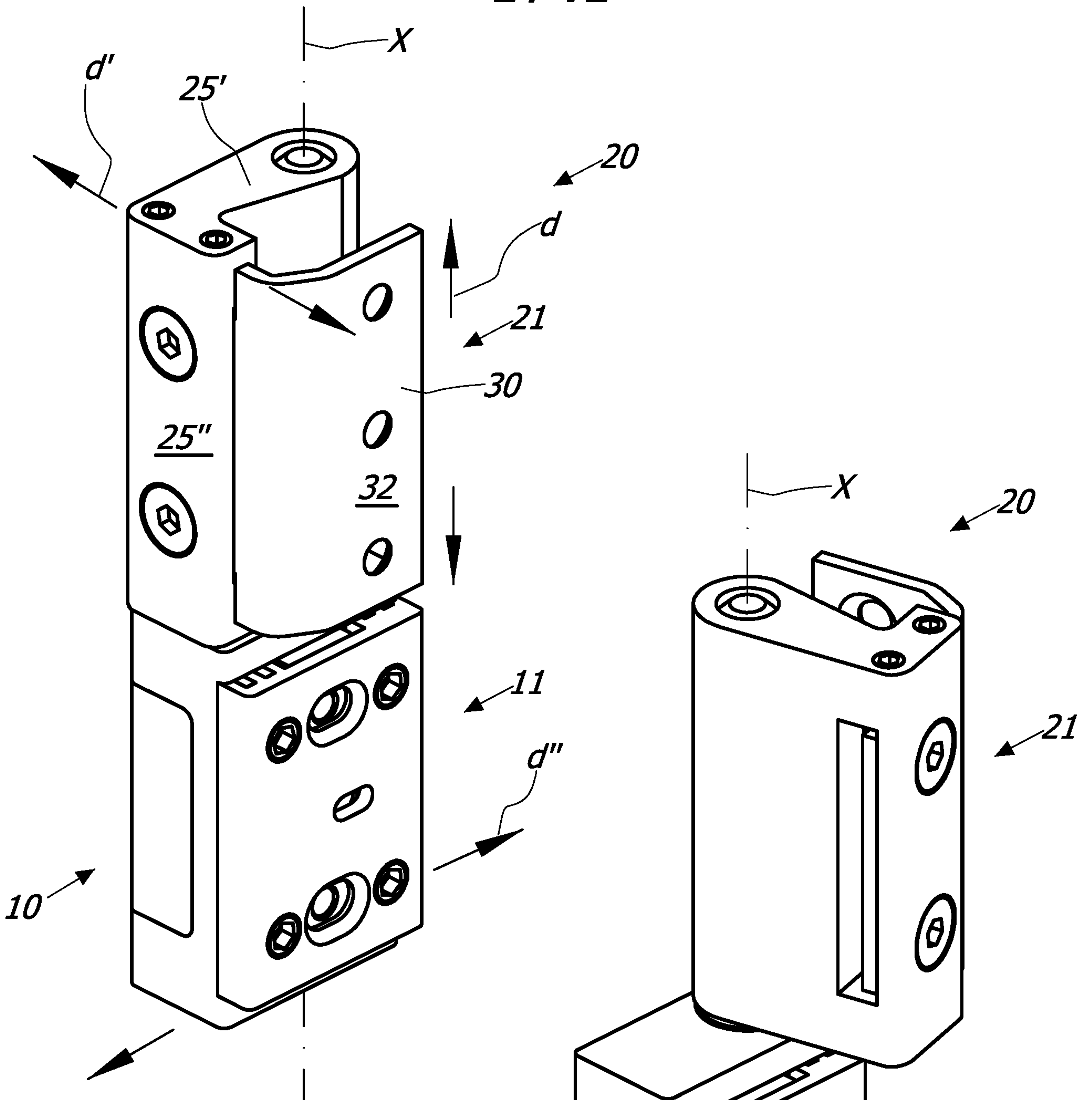

FIG. 2a

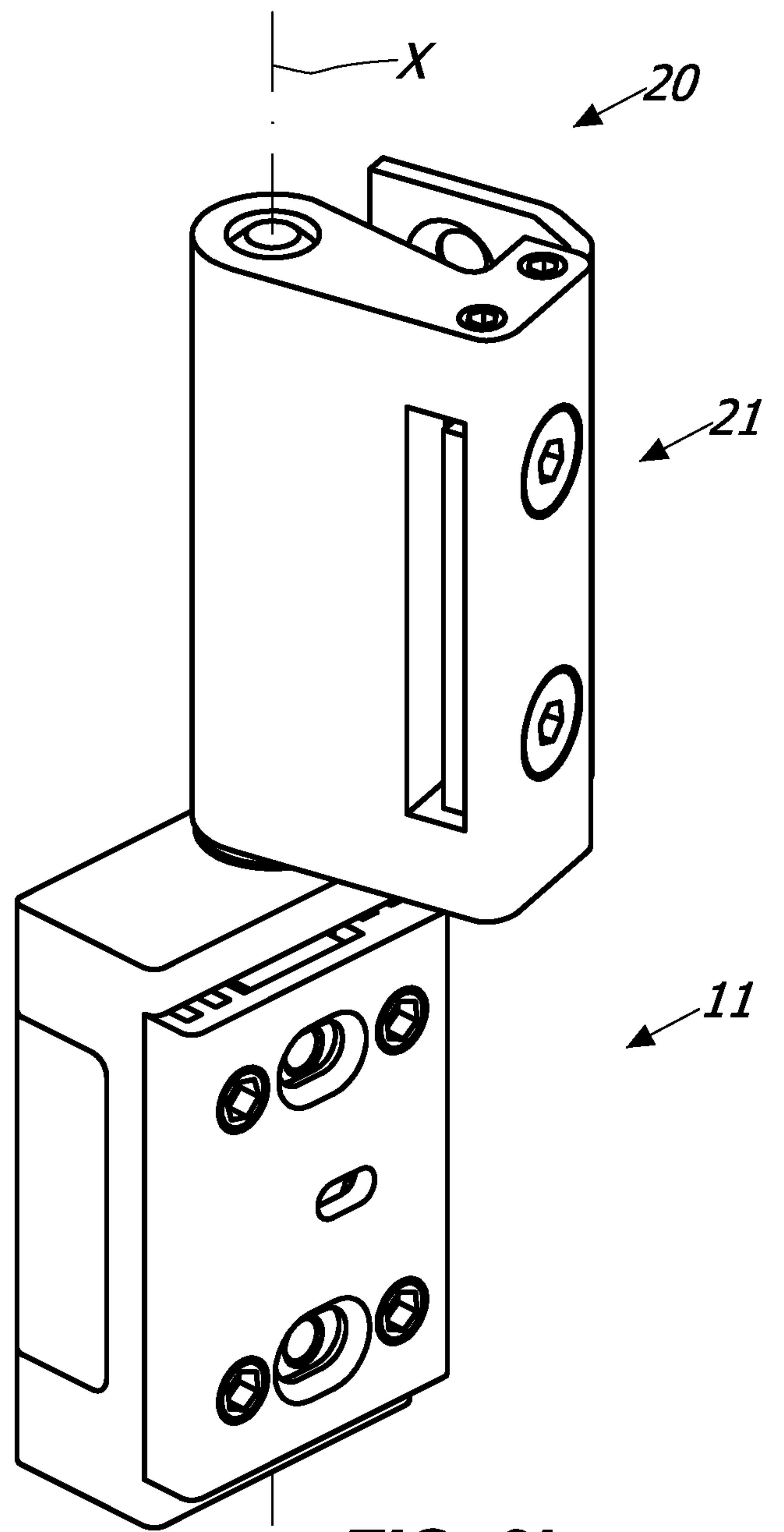

FIG. 2b

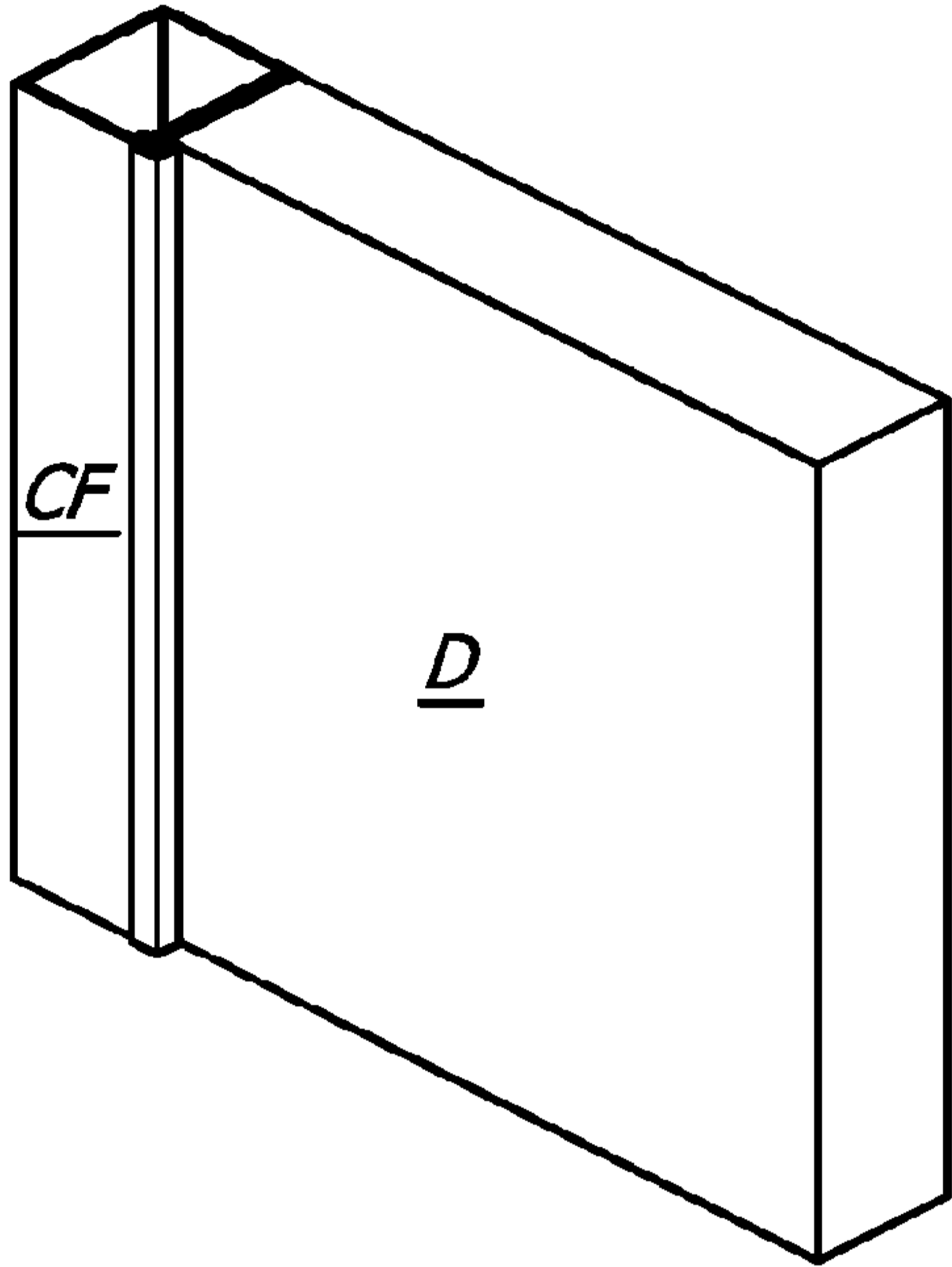

FIG. 3a

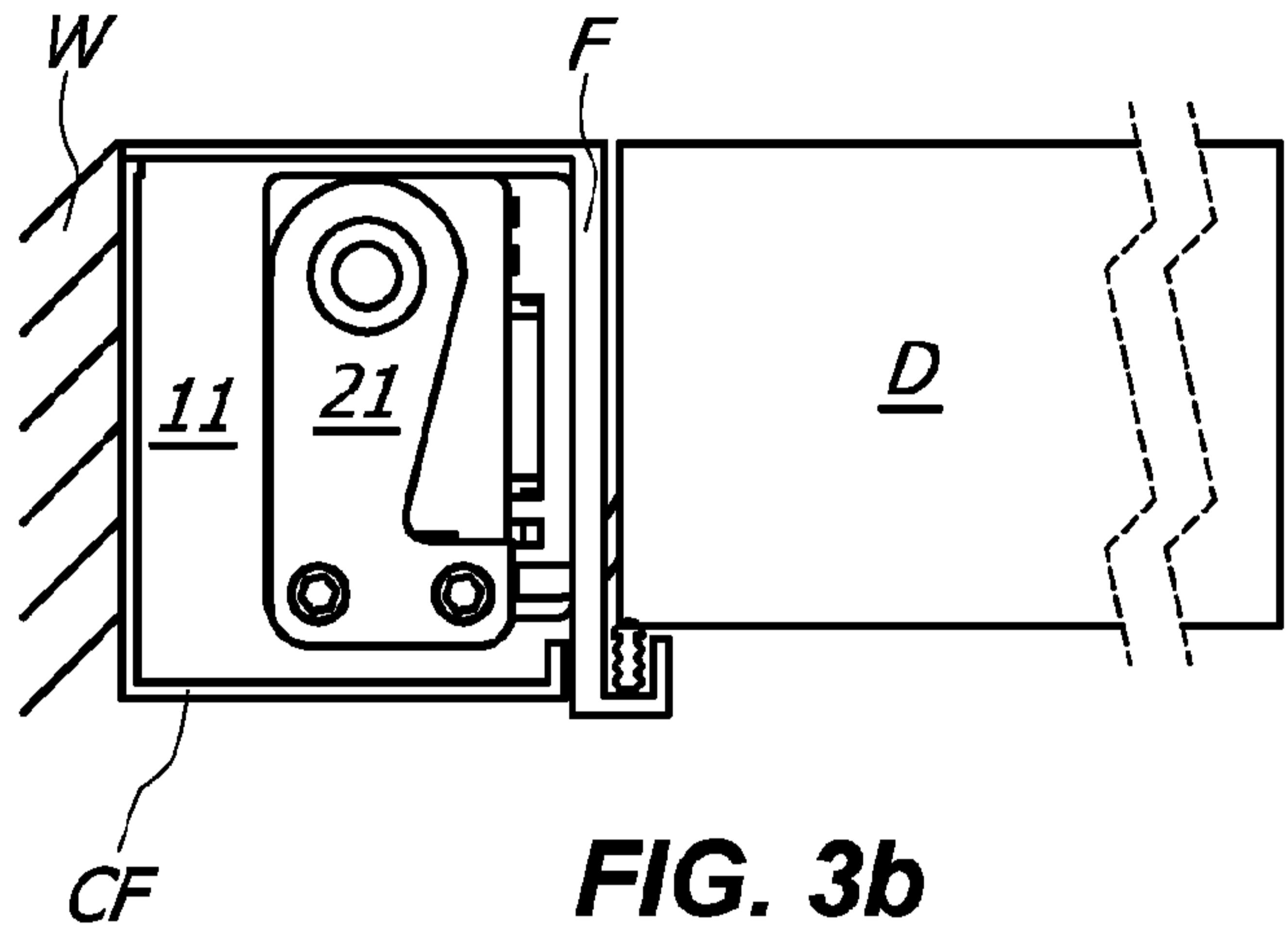

FIG. 3b

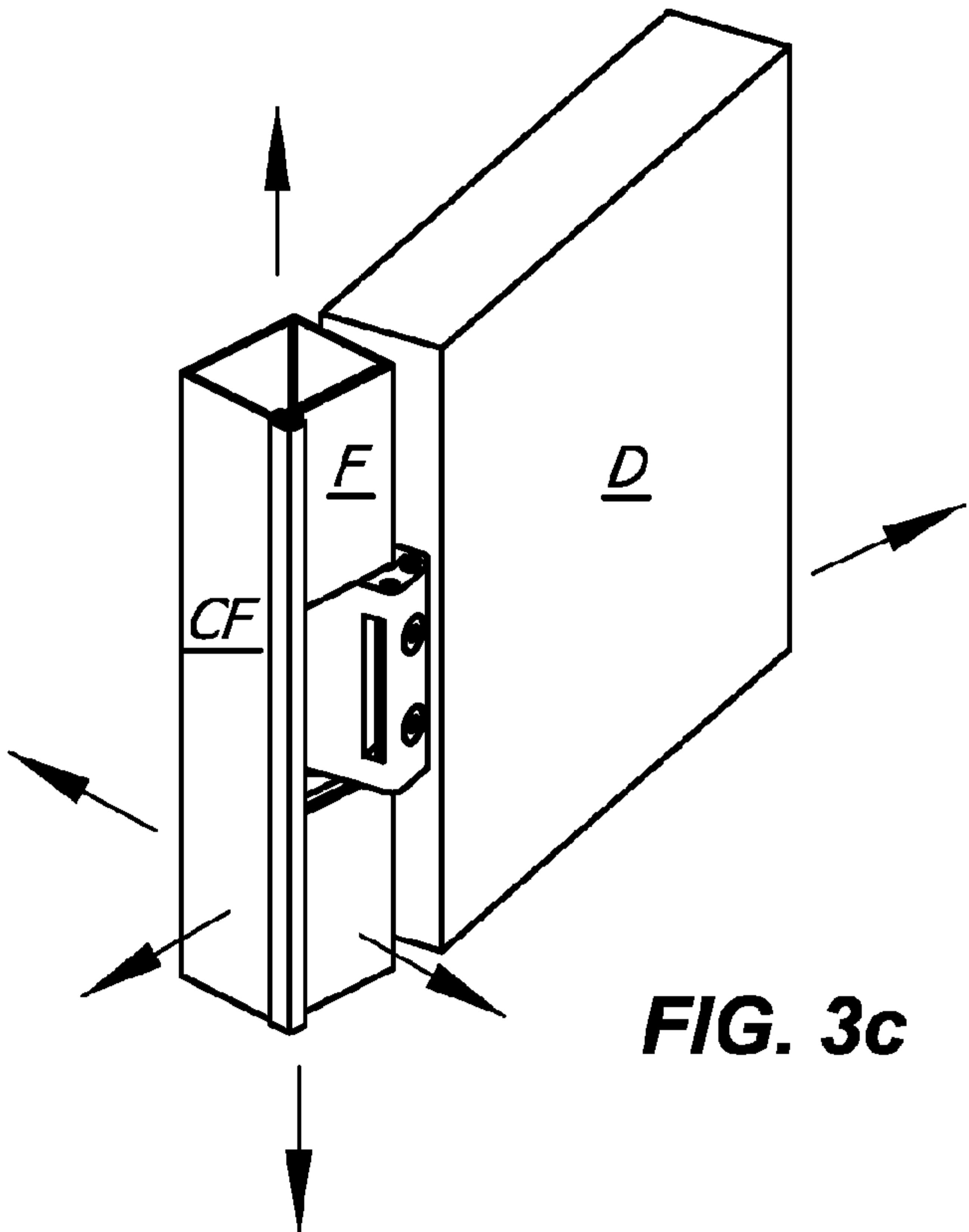

FIG. 3c

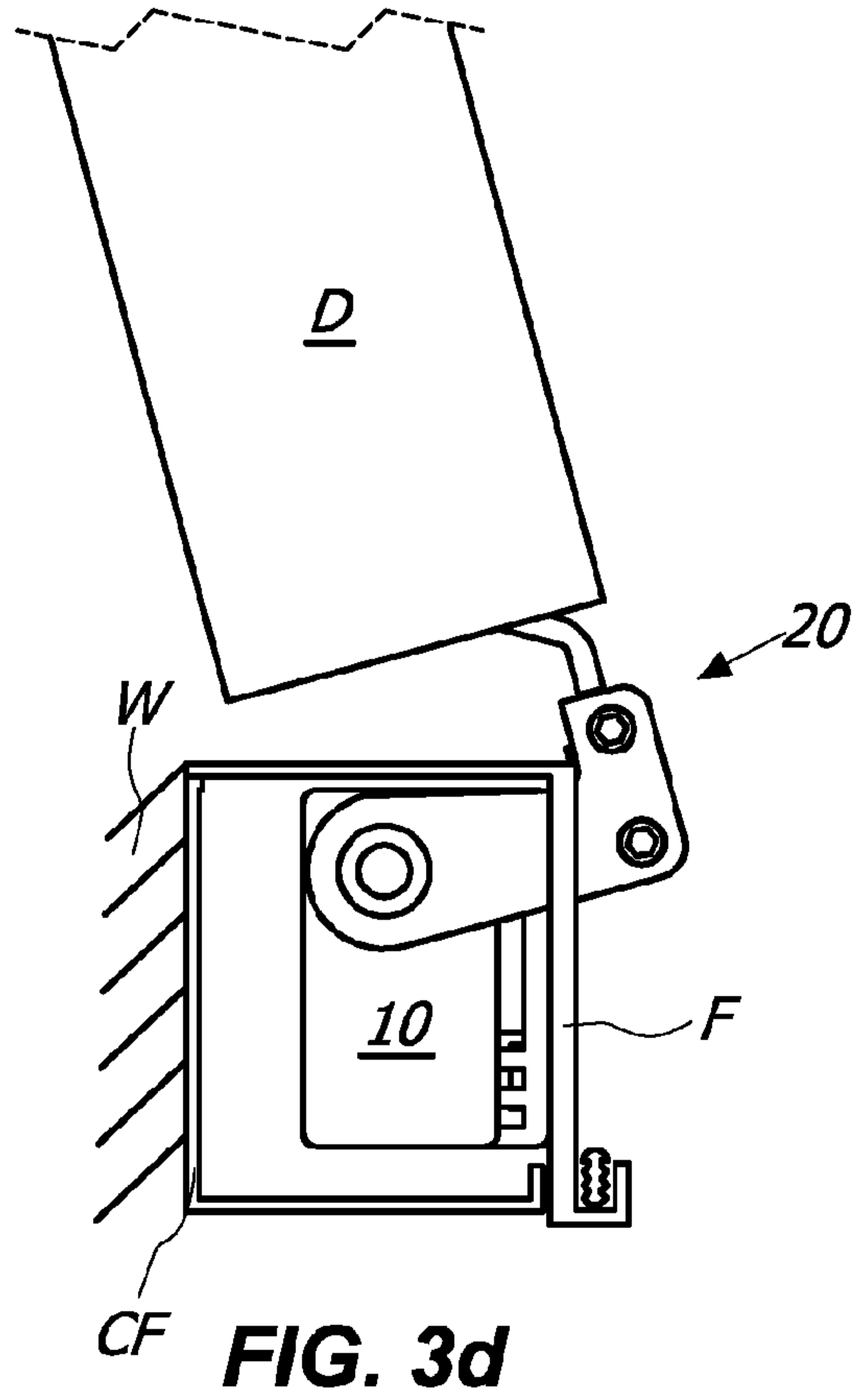

FIG. 3d

4 / 12

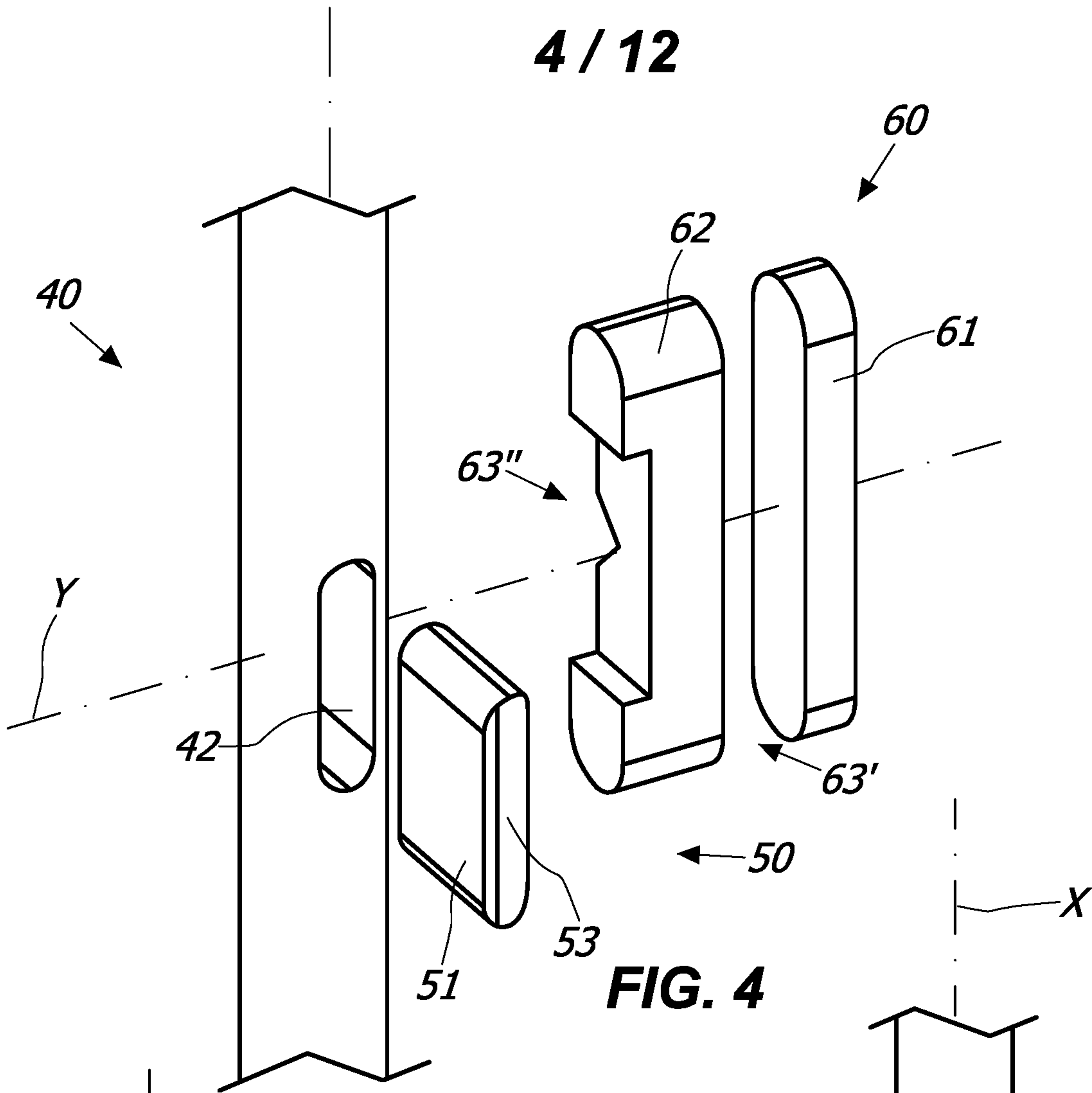

FIG. 4

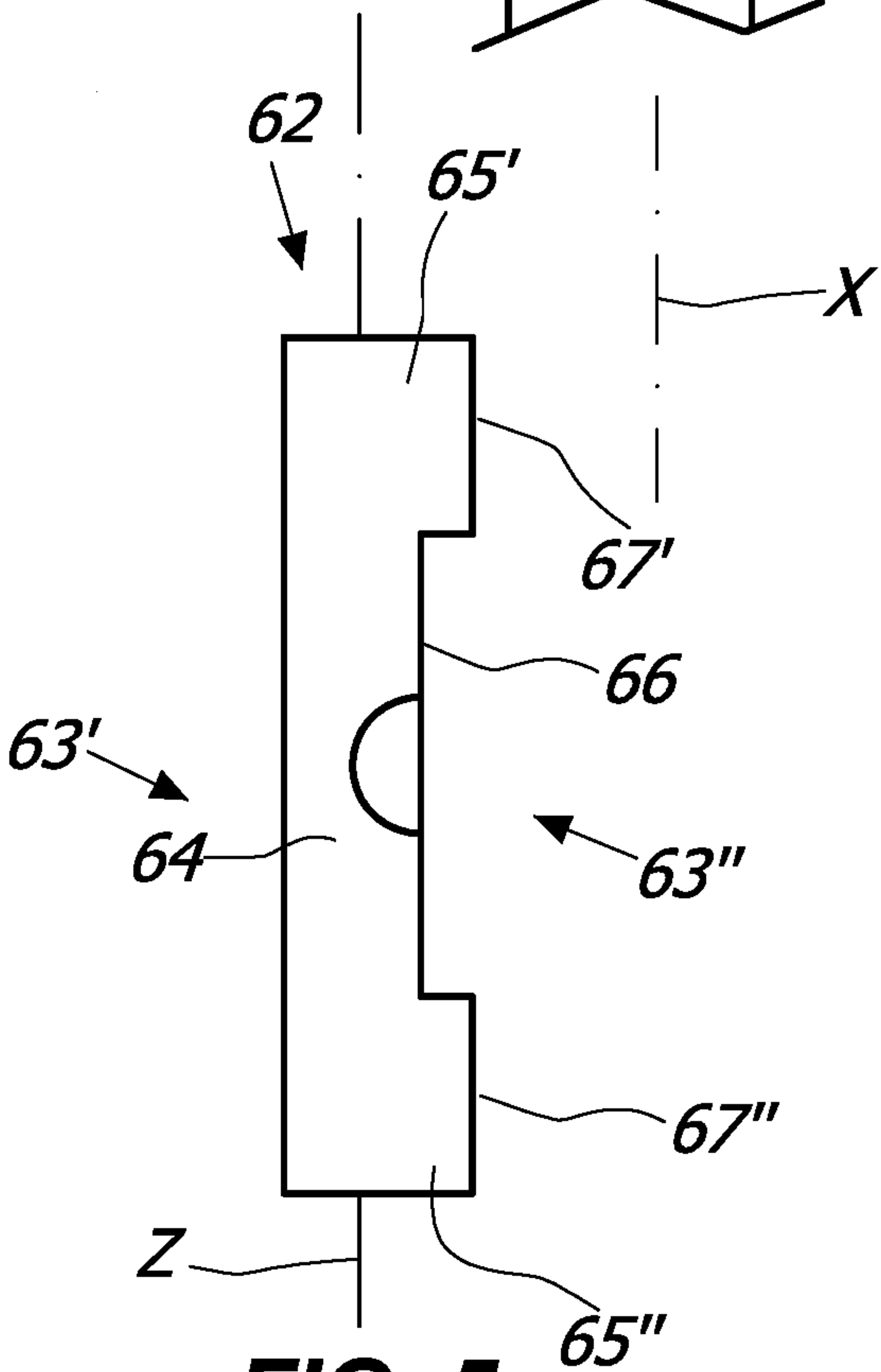

FIG. 5

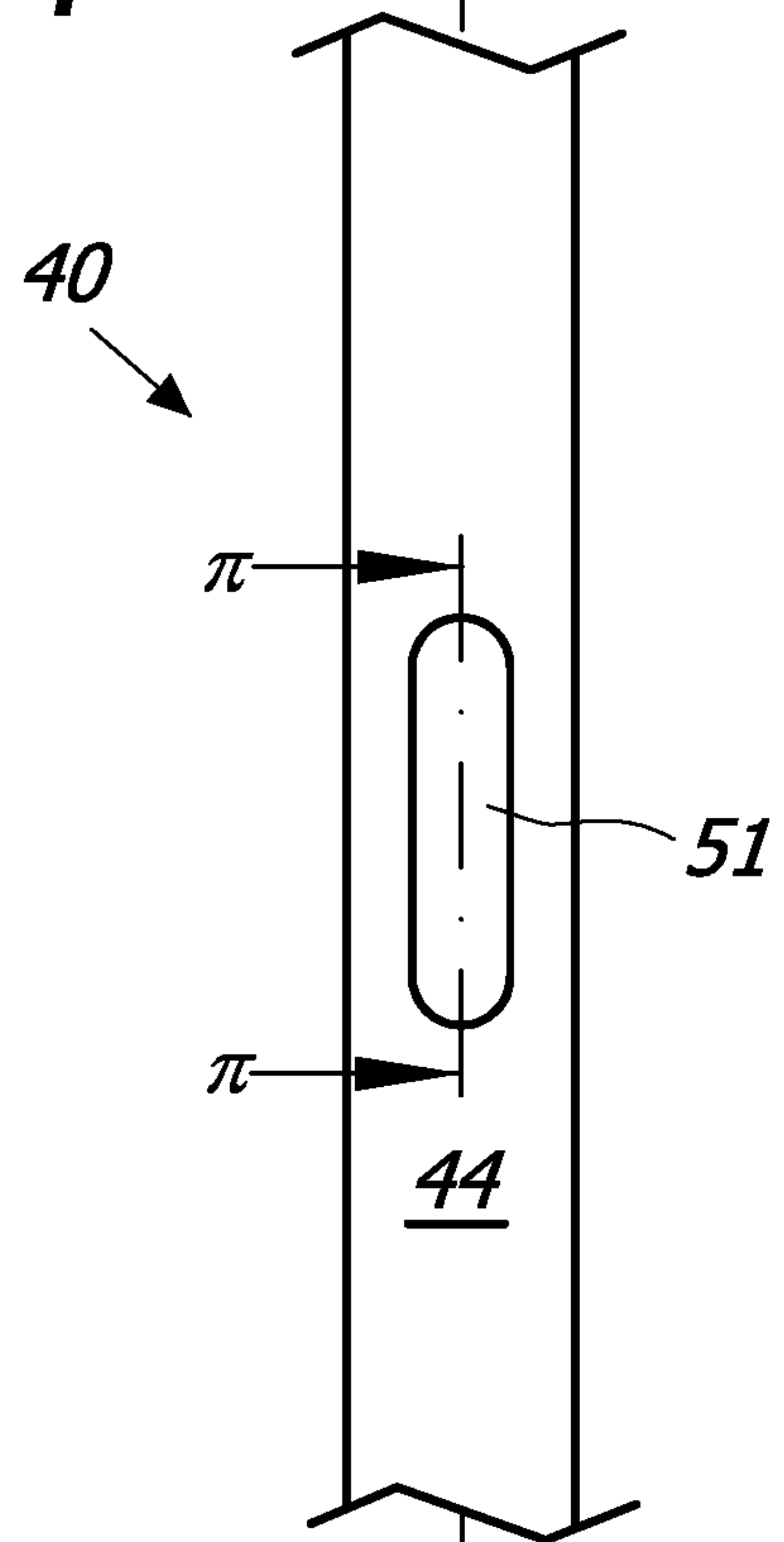

FIG. 6

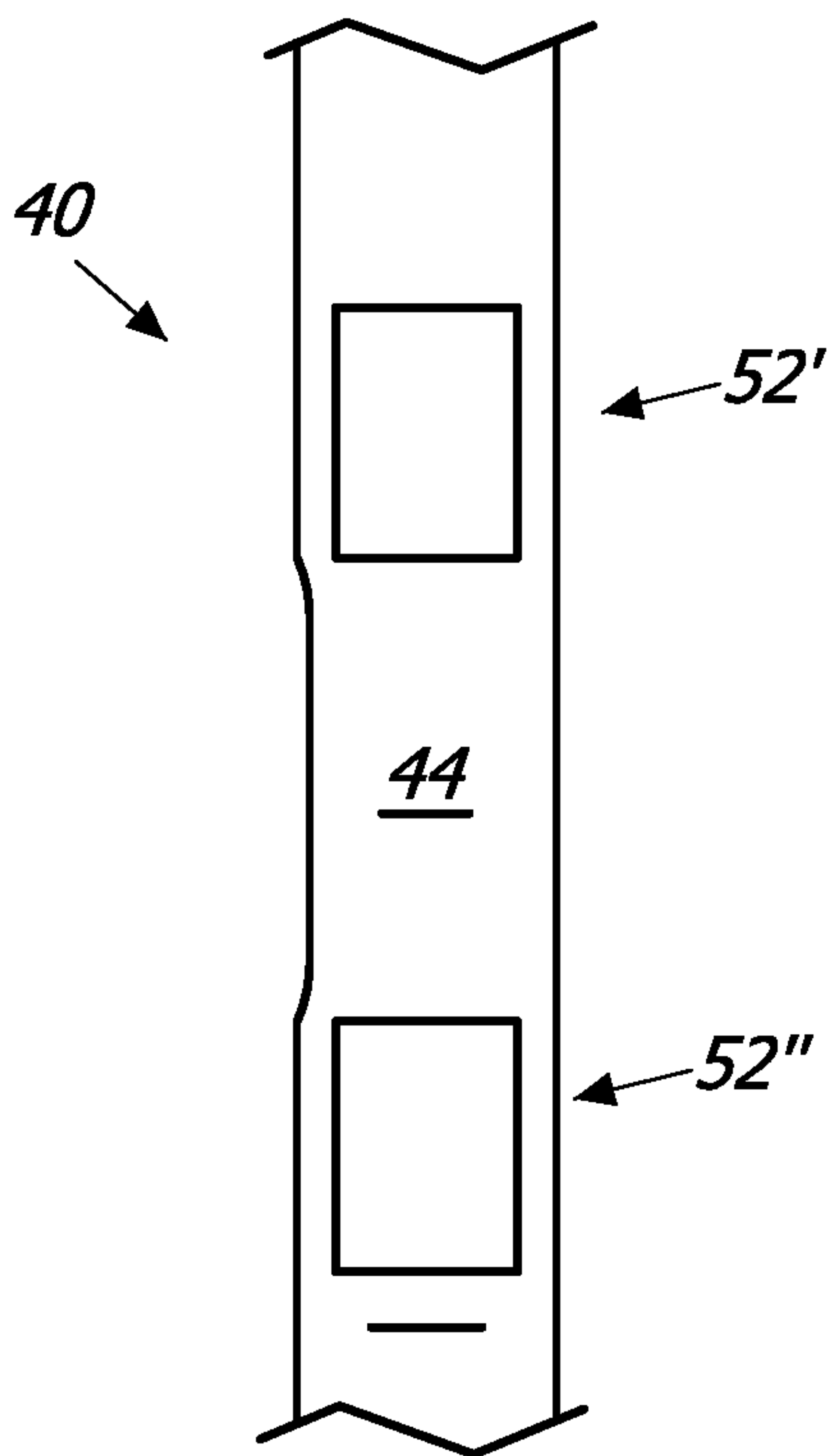

FIG. 7a

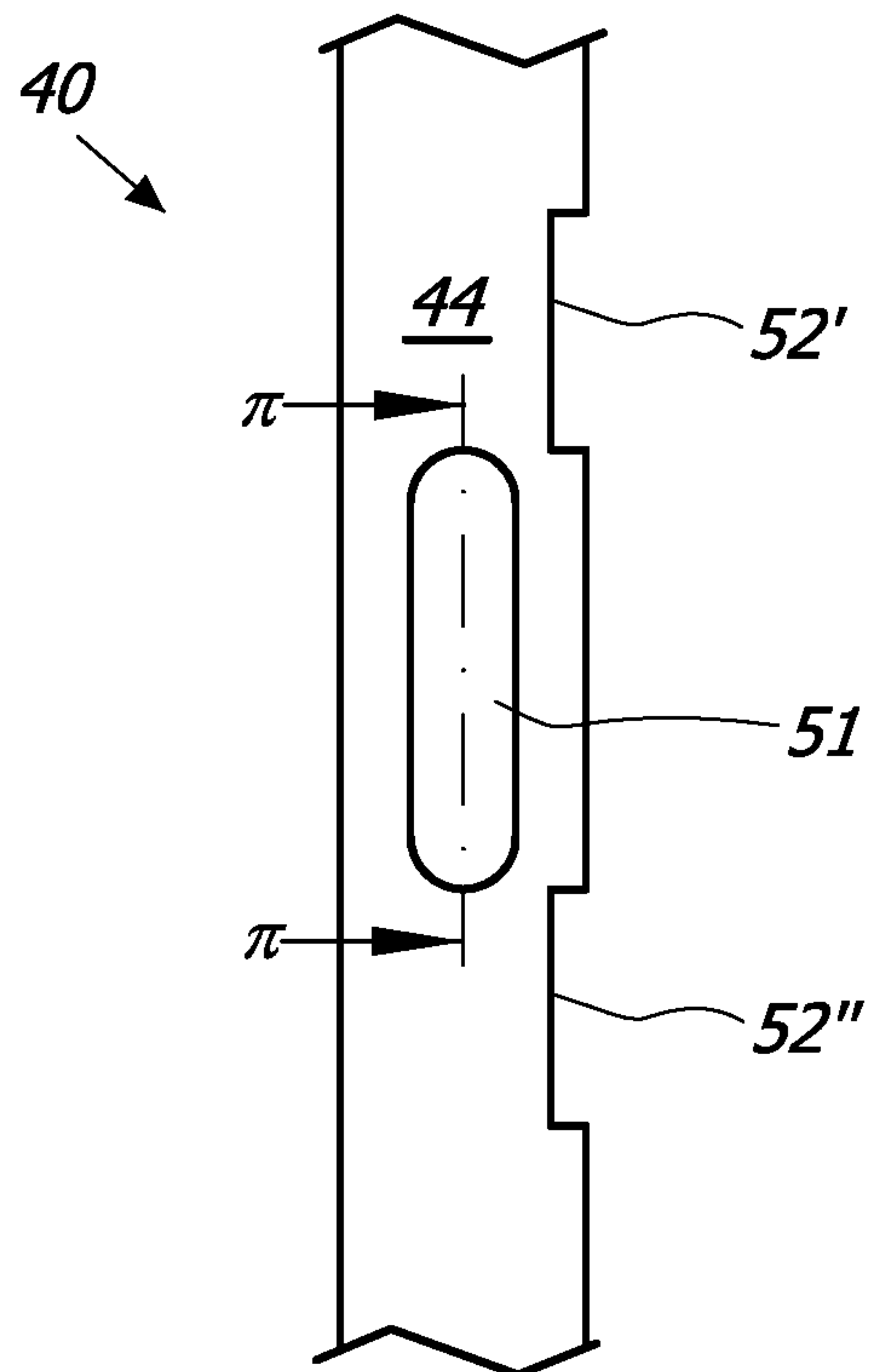

FIG. 7b

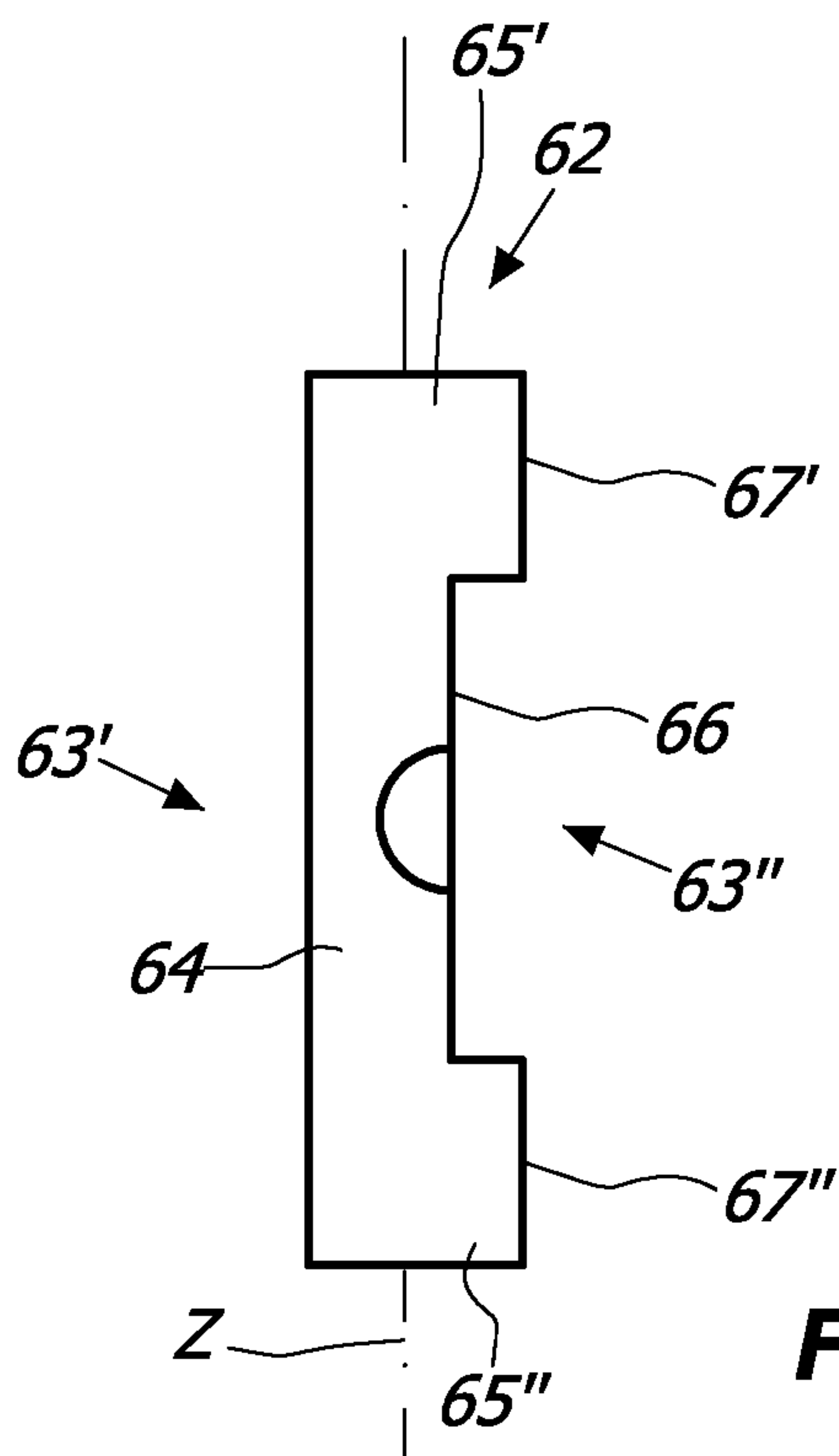

FIG. 7c

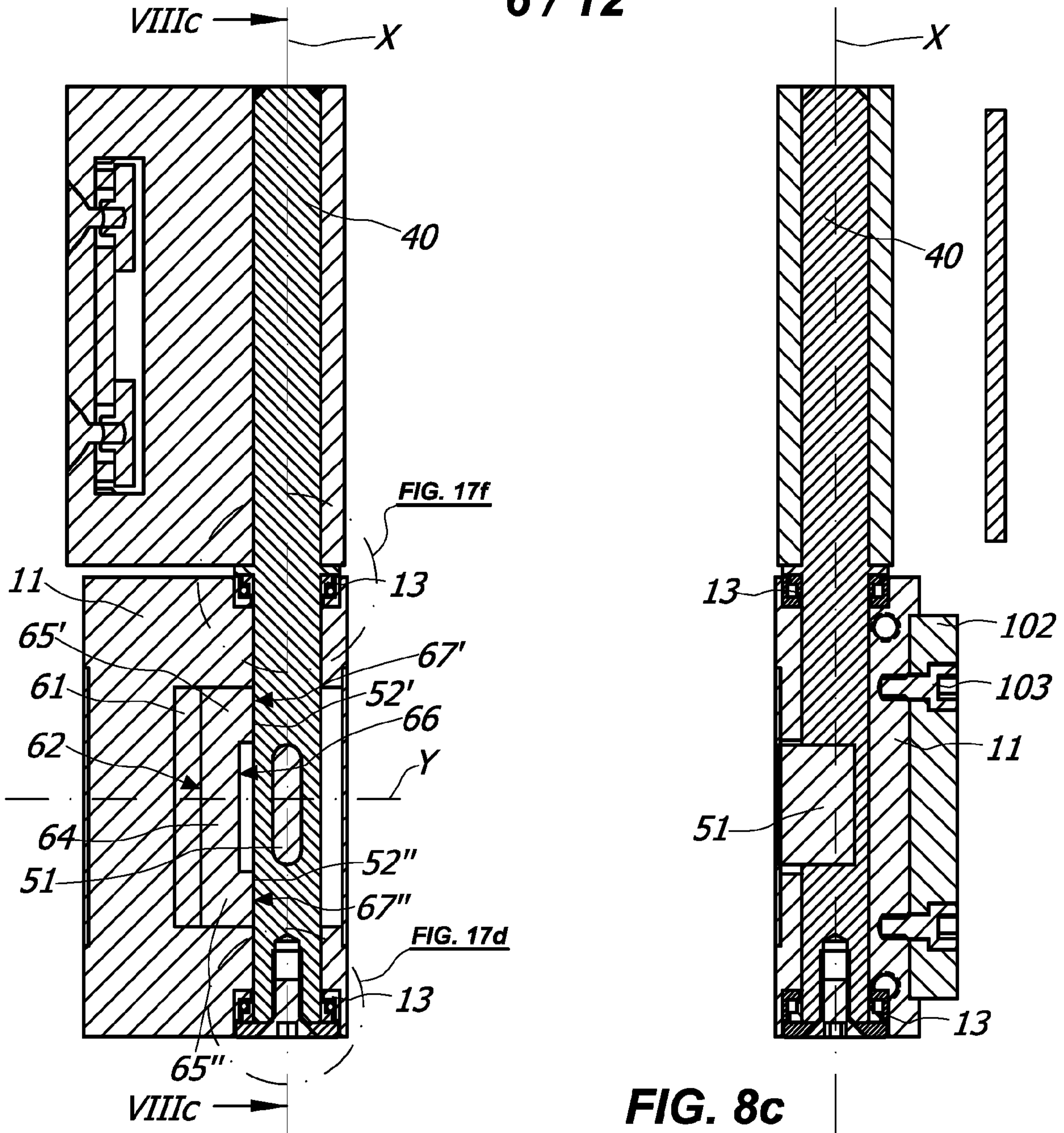

FIG. 8b

FIG. 8c

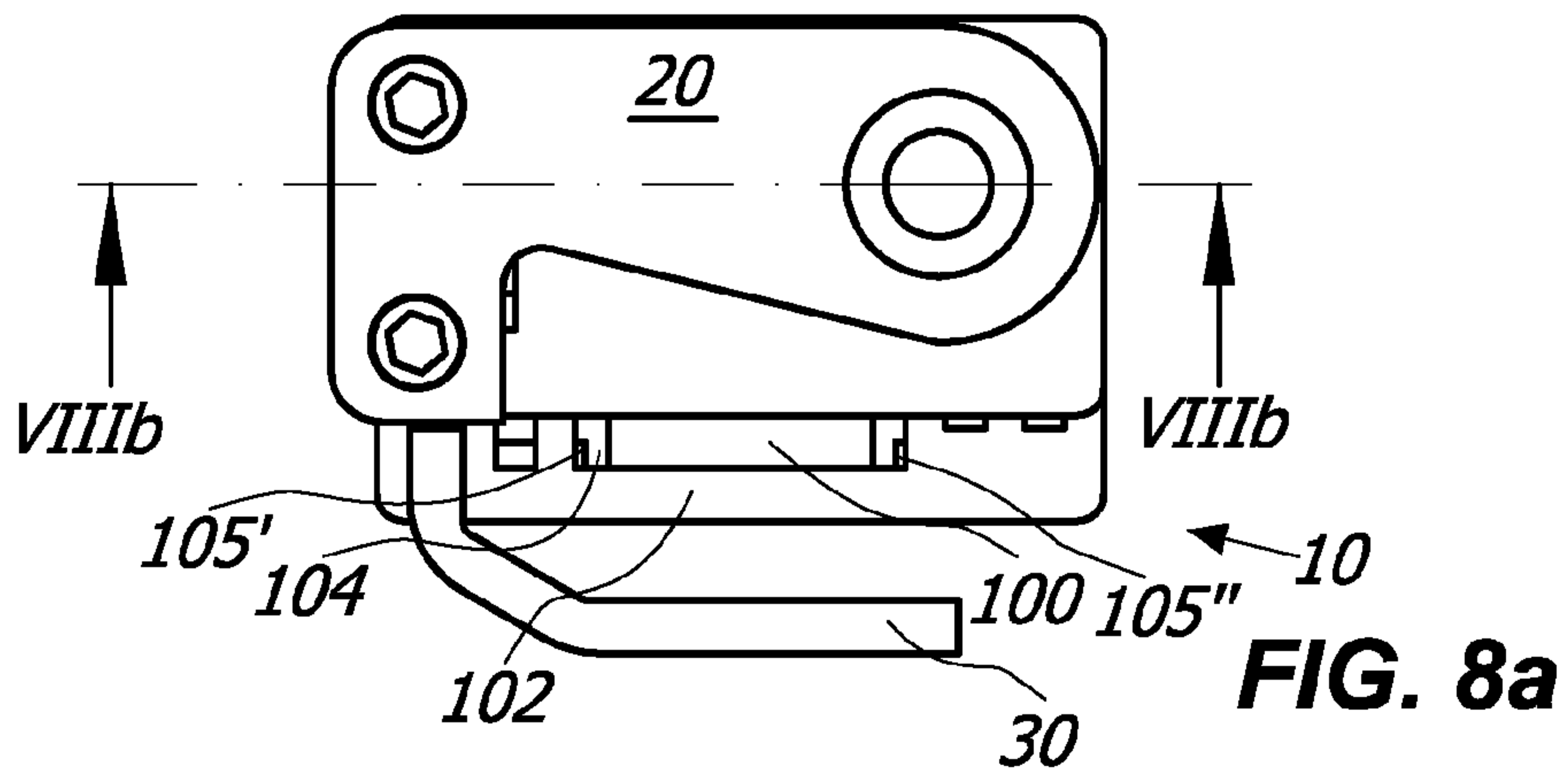

FIG. 8a

7 / 12

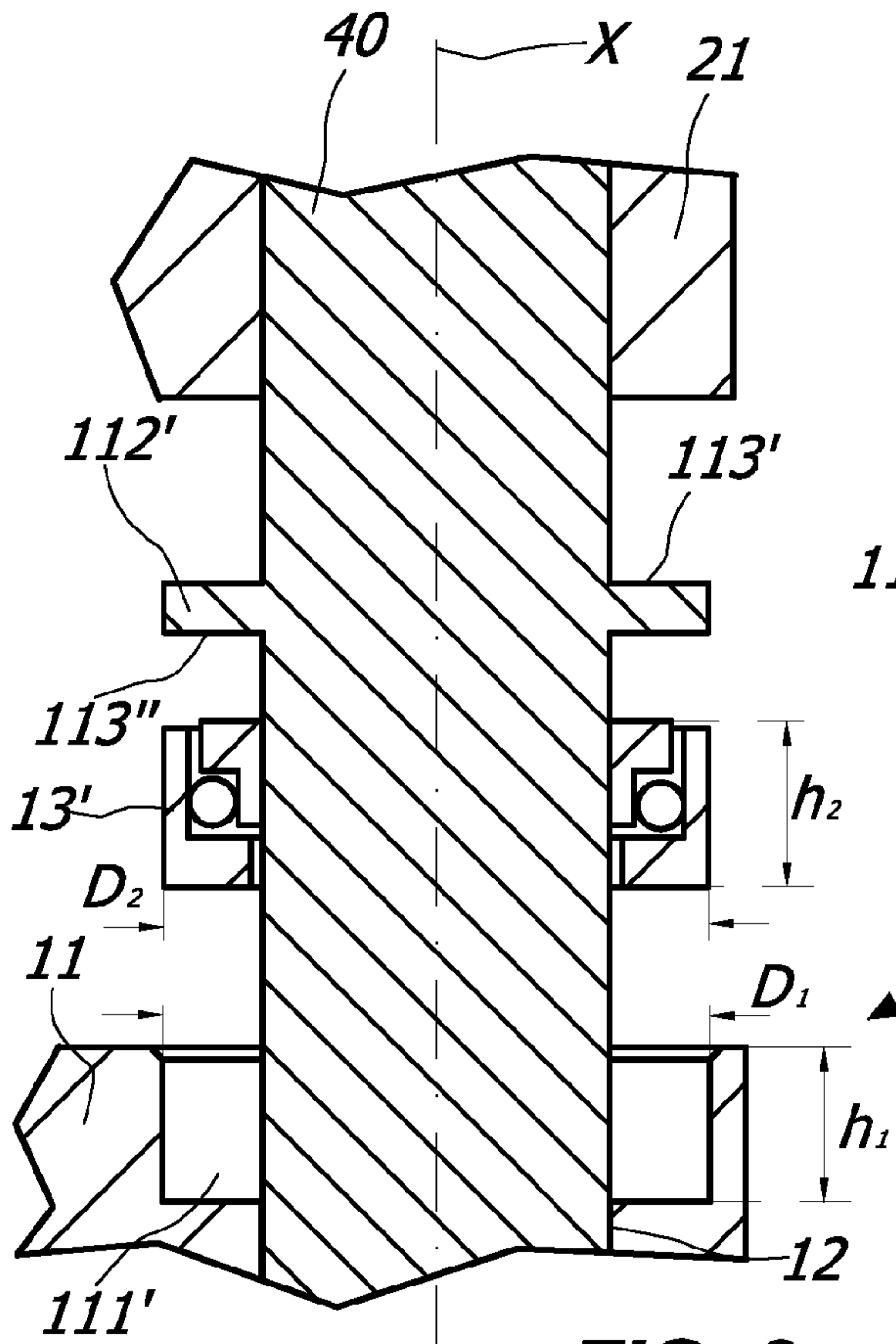

FIG. 9a

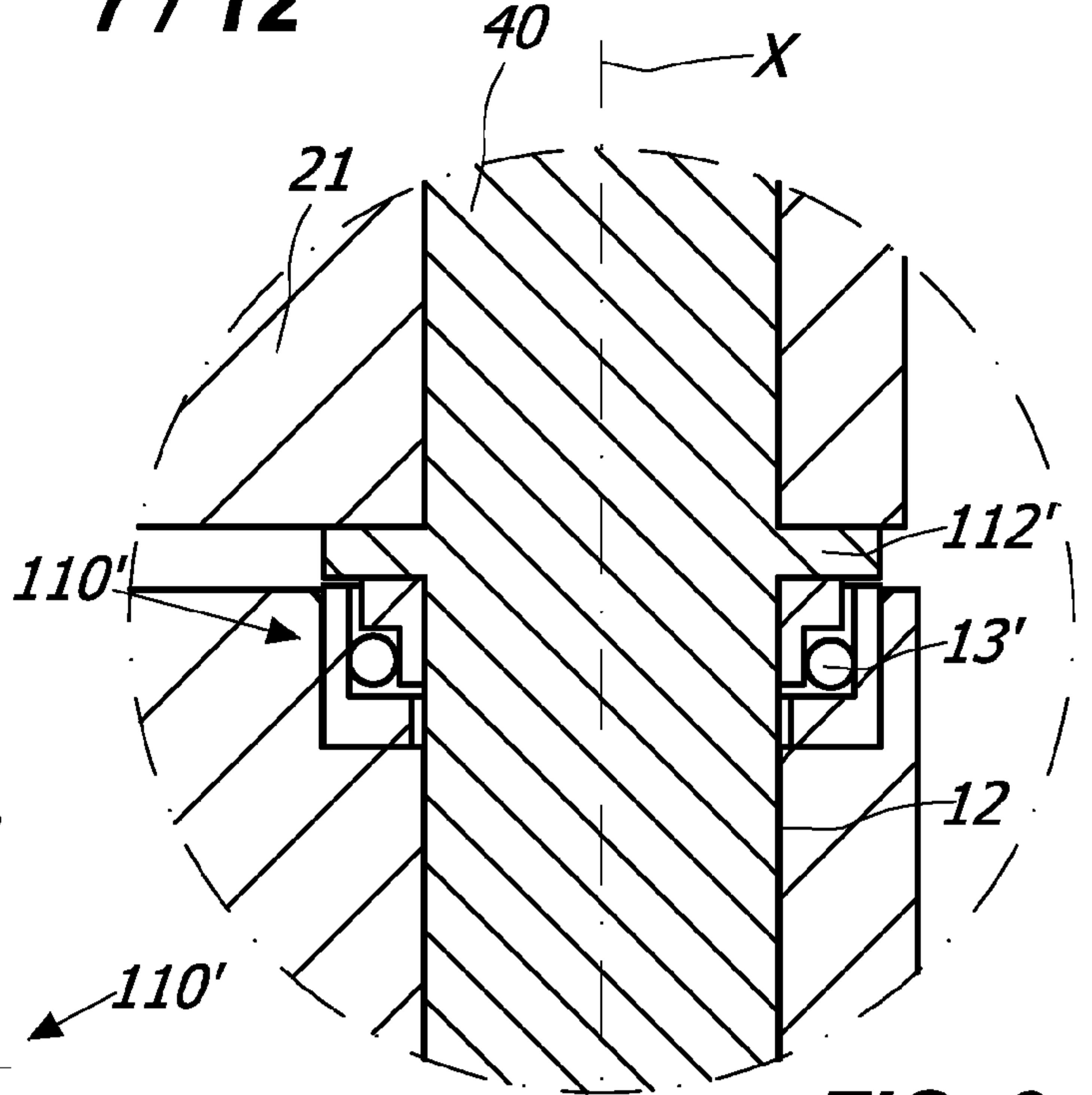

FIG. 9

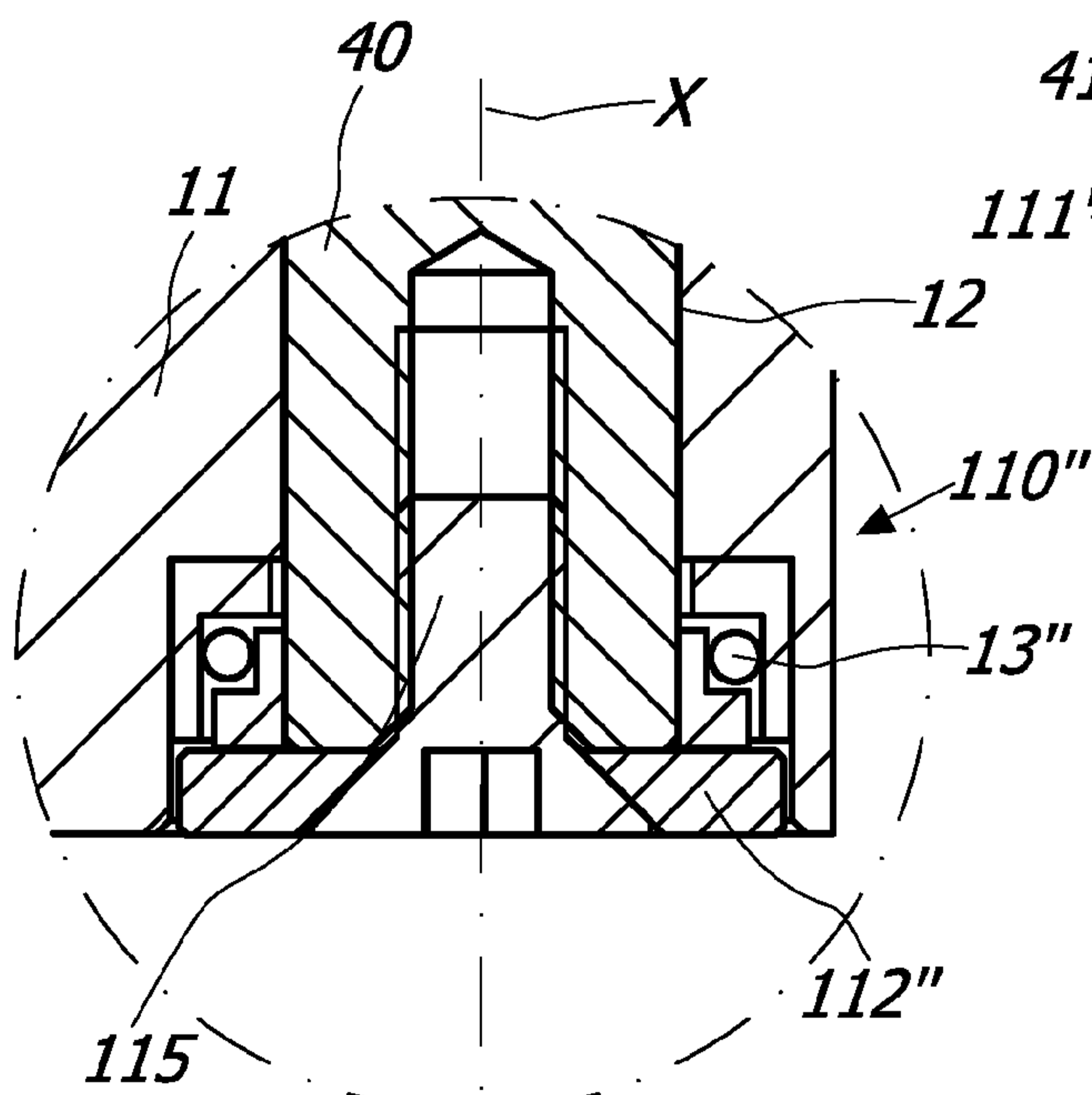

FIG. 10

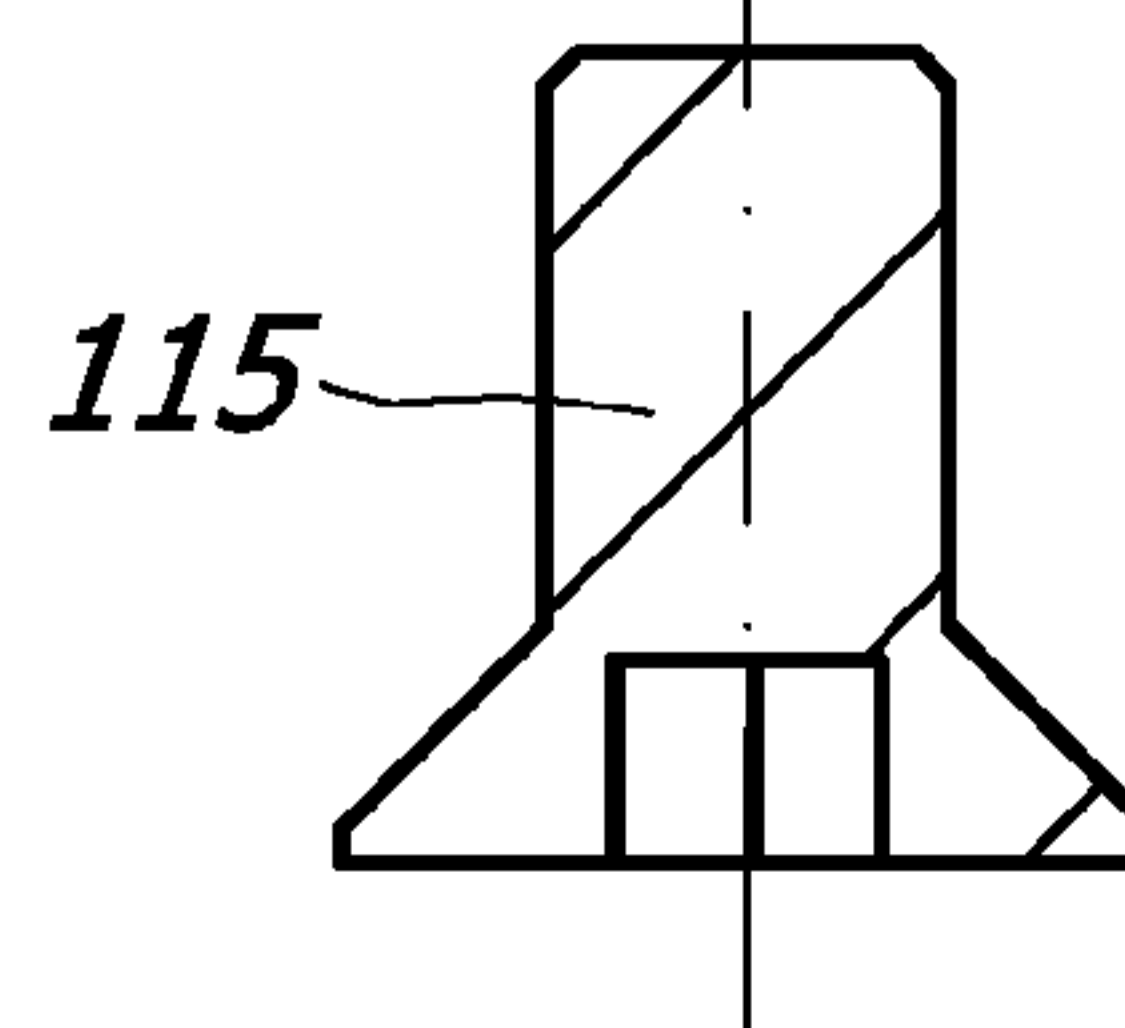
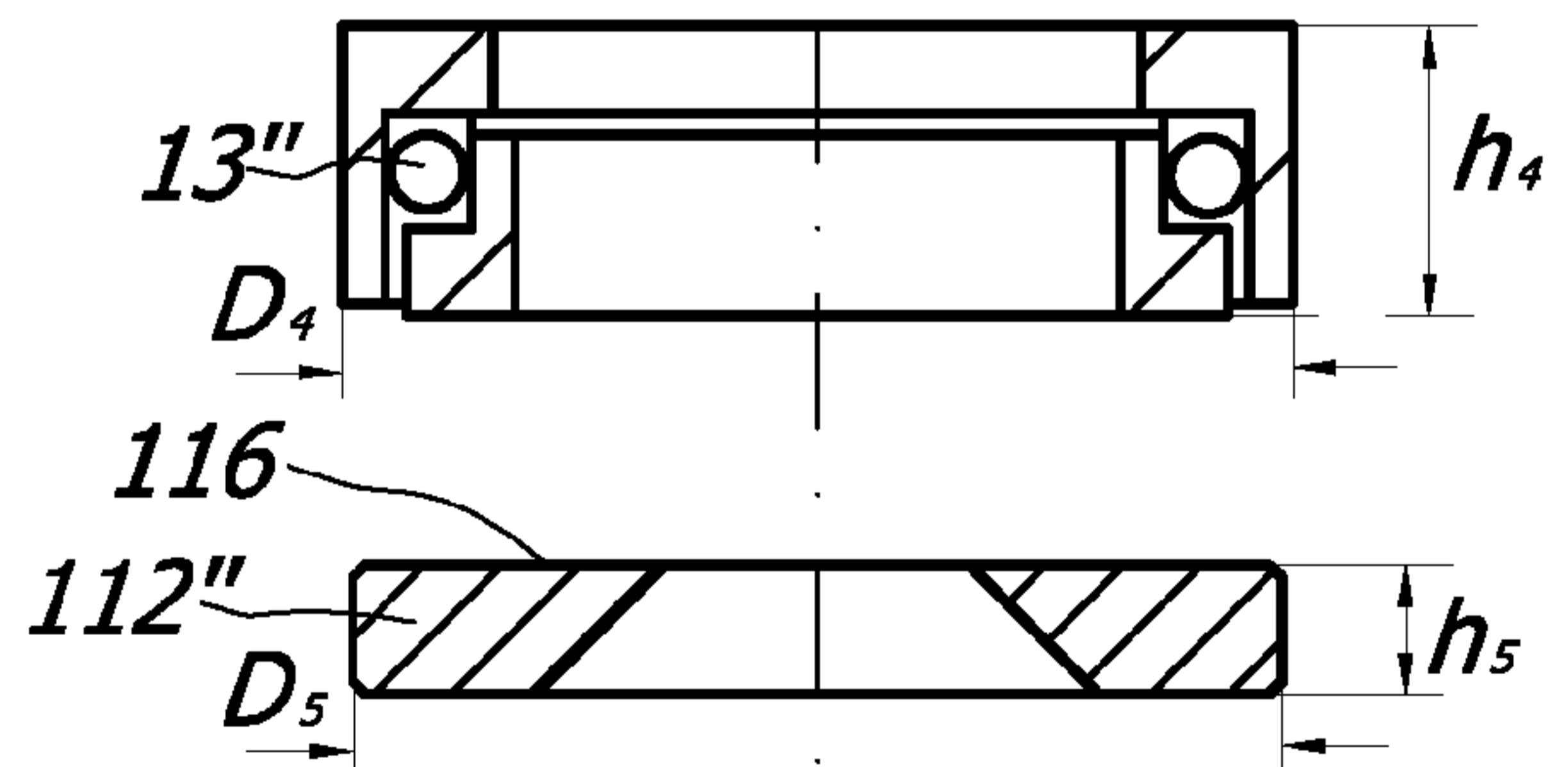
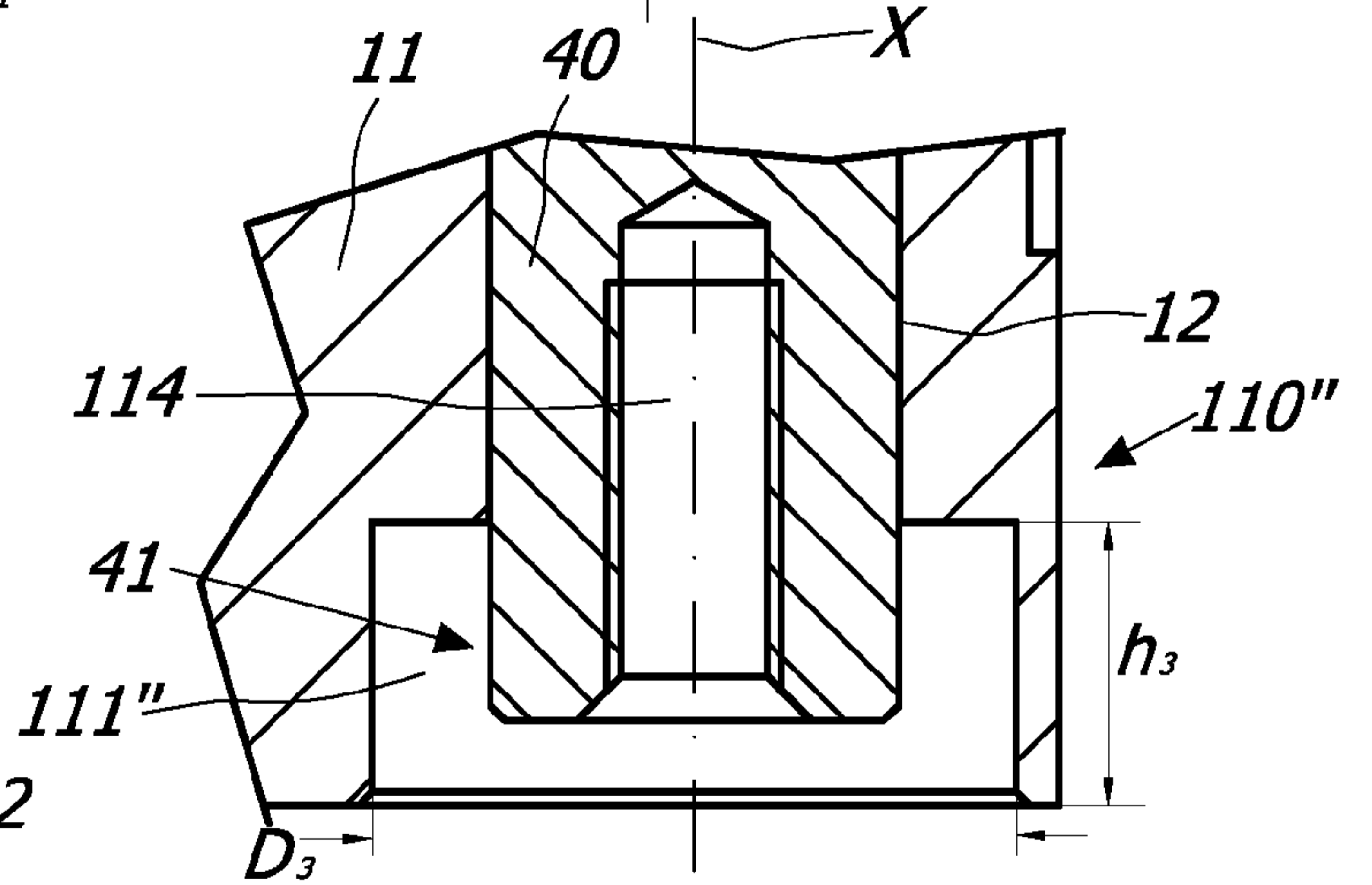

FIG. 10a

8 / 12

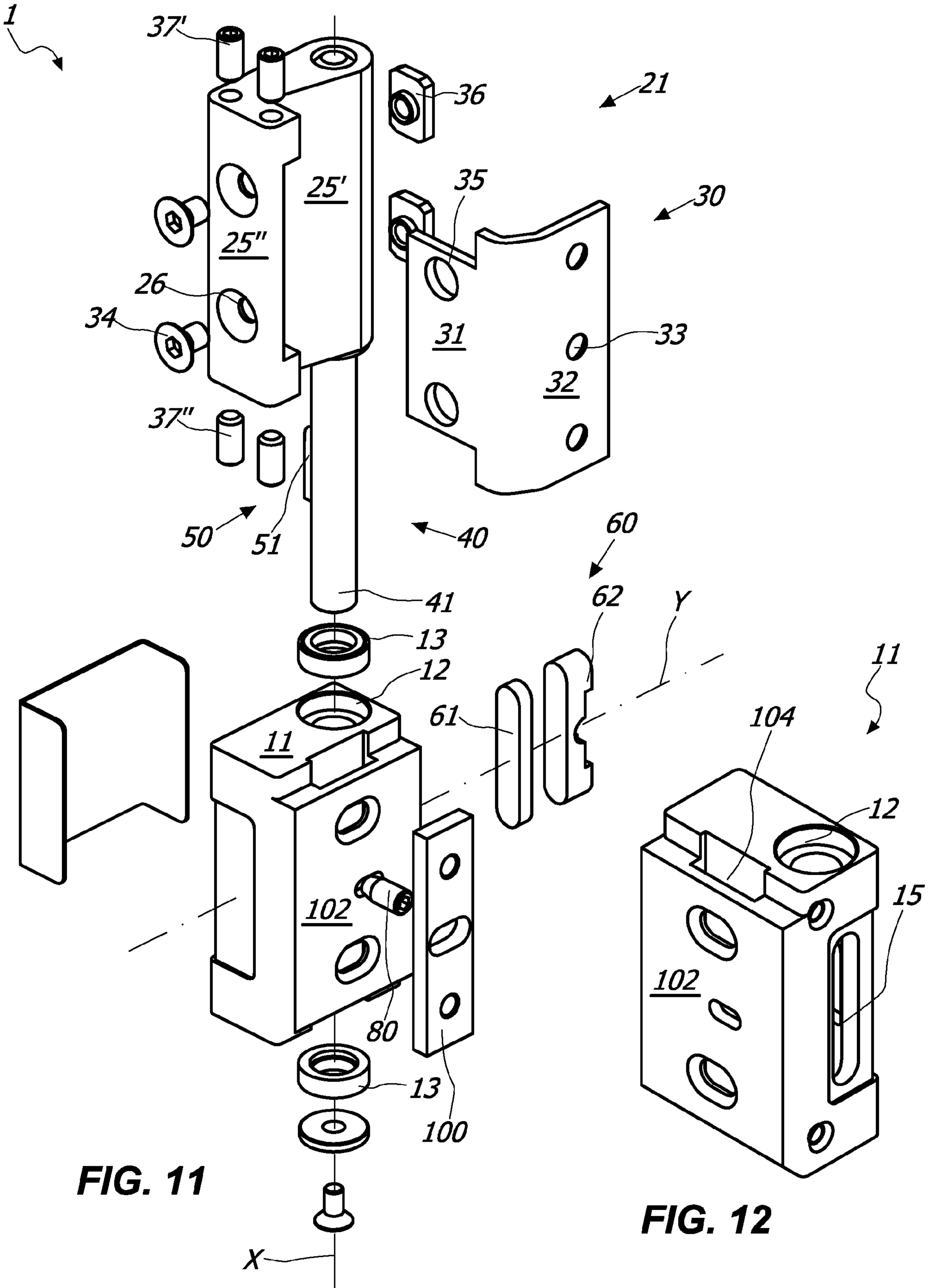

FIG. 11

FIG. 12

9 / 12

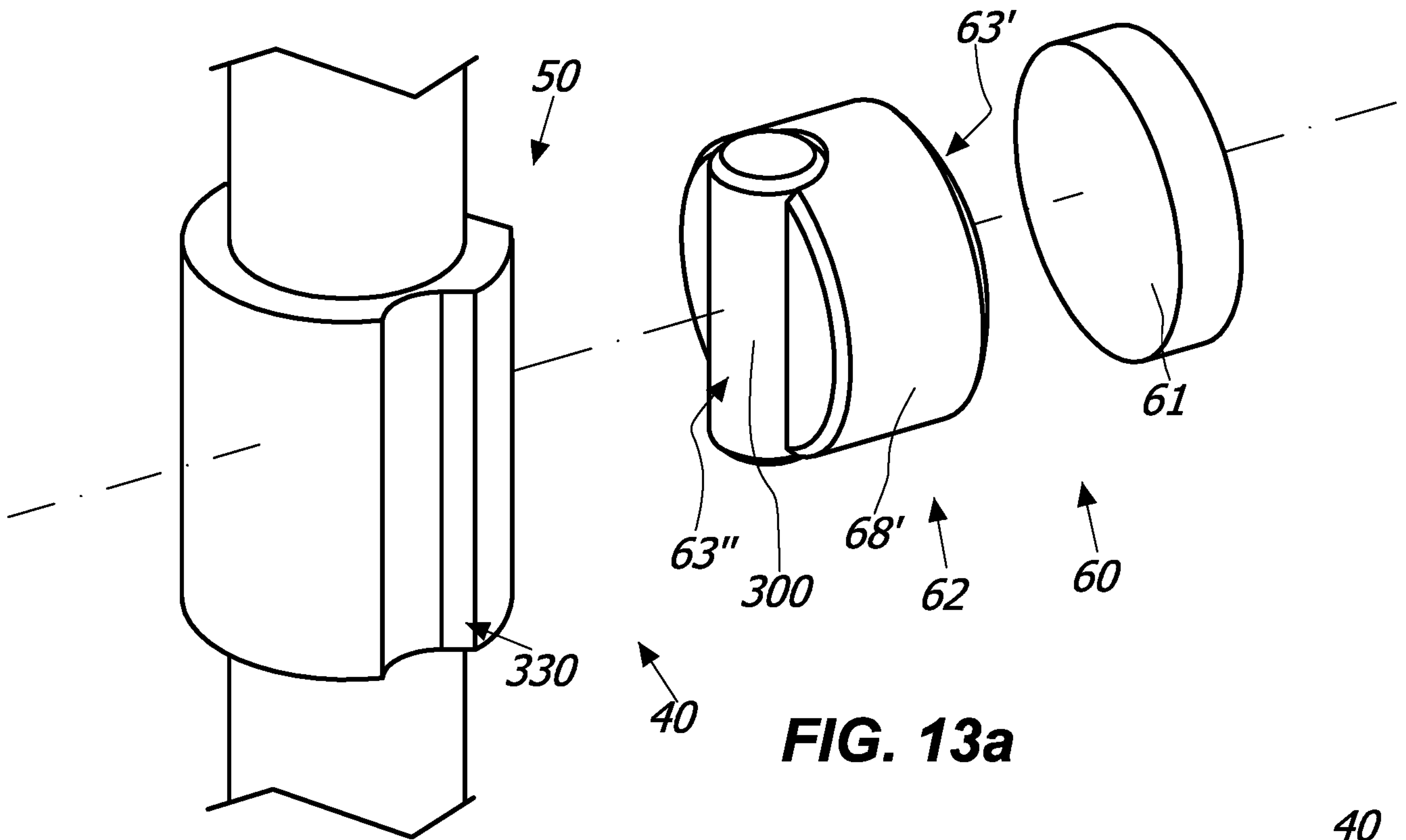

FIG. 13a

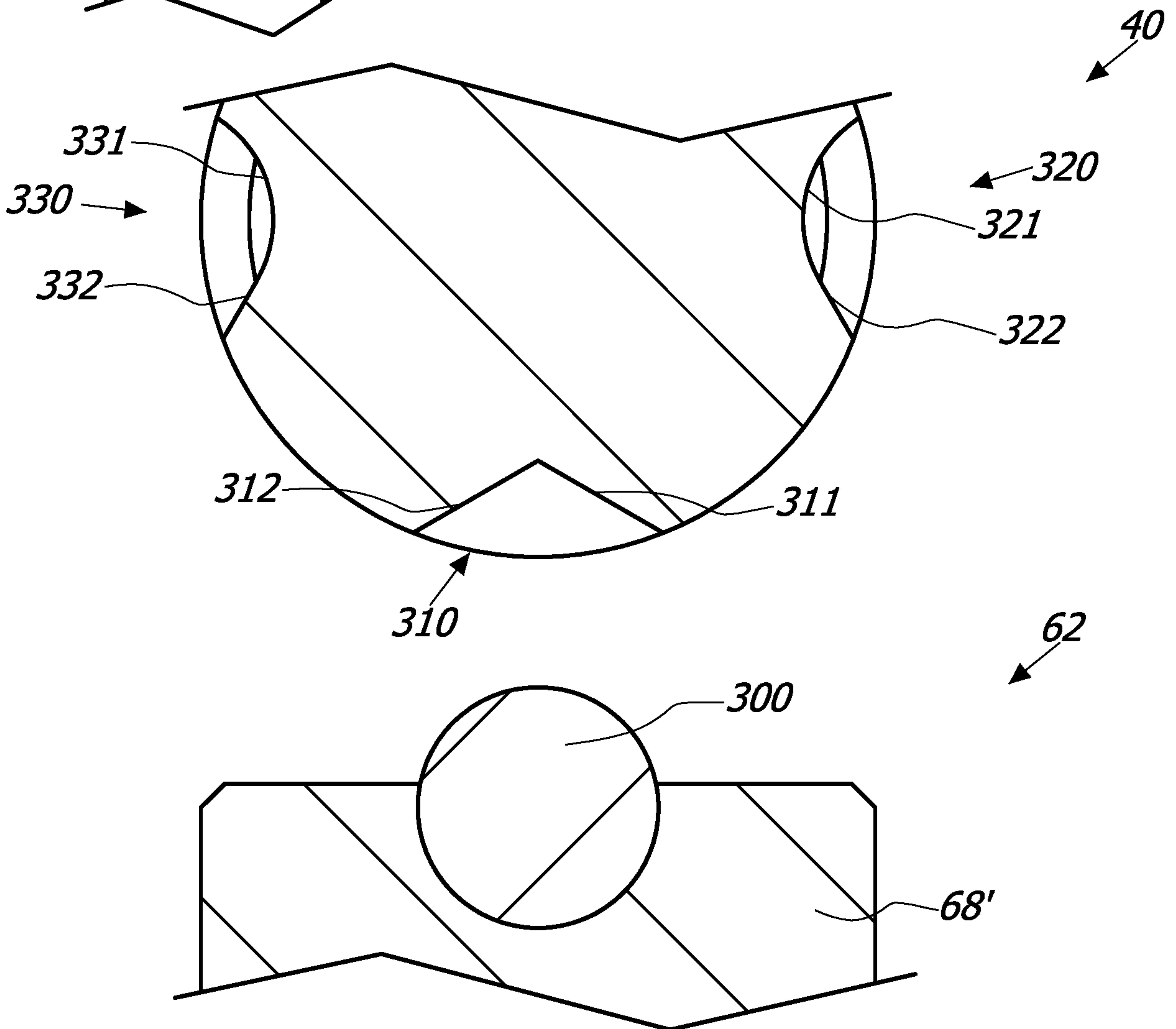

FIG. 13b

10 / 12

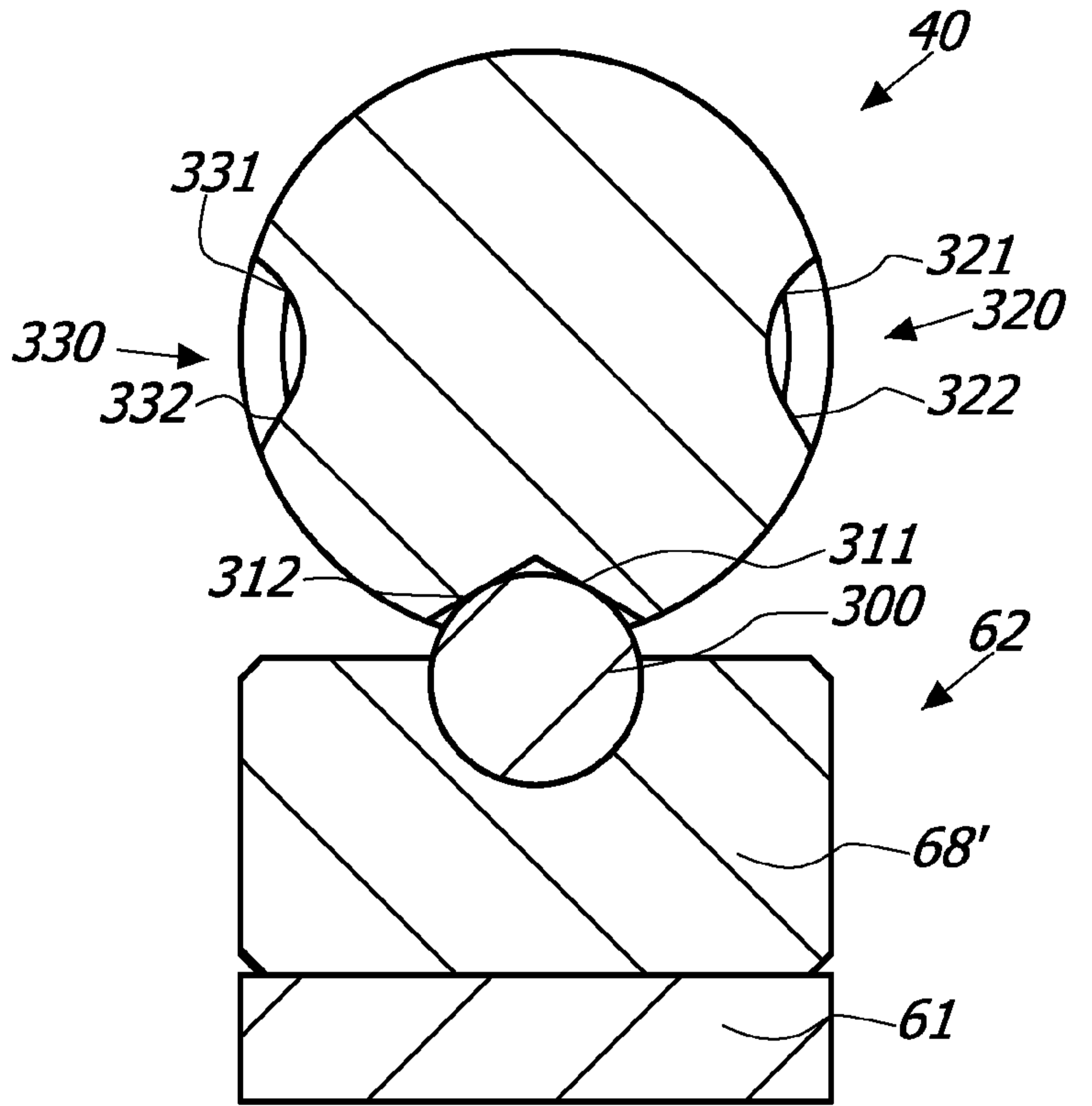

FIG. 14

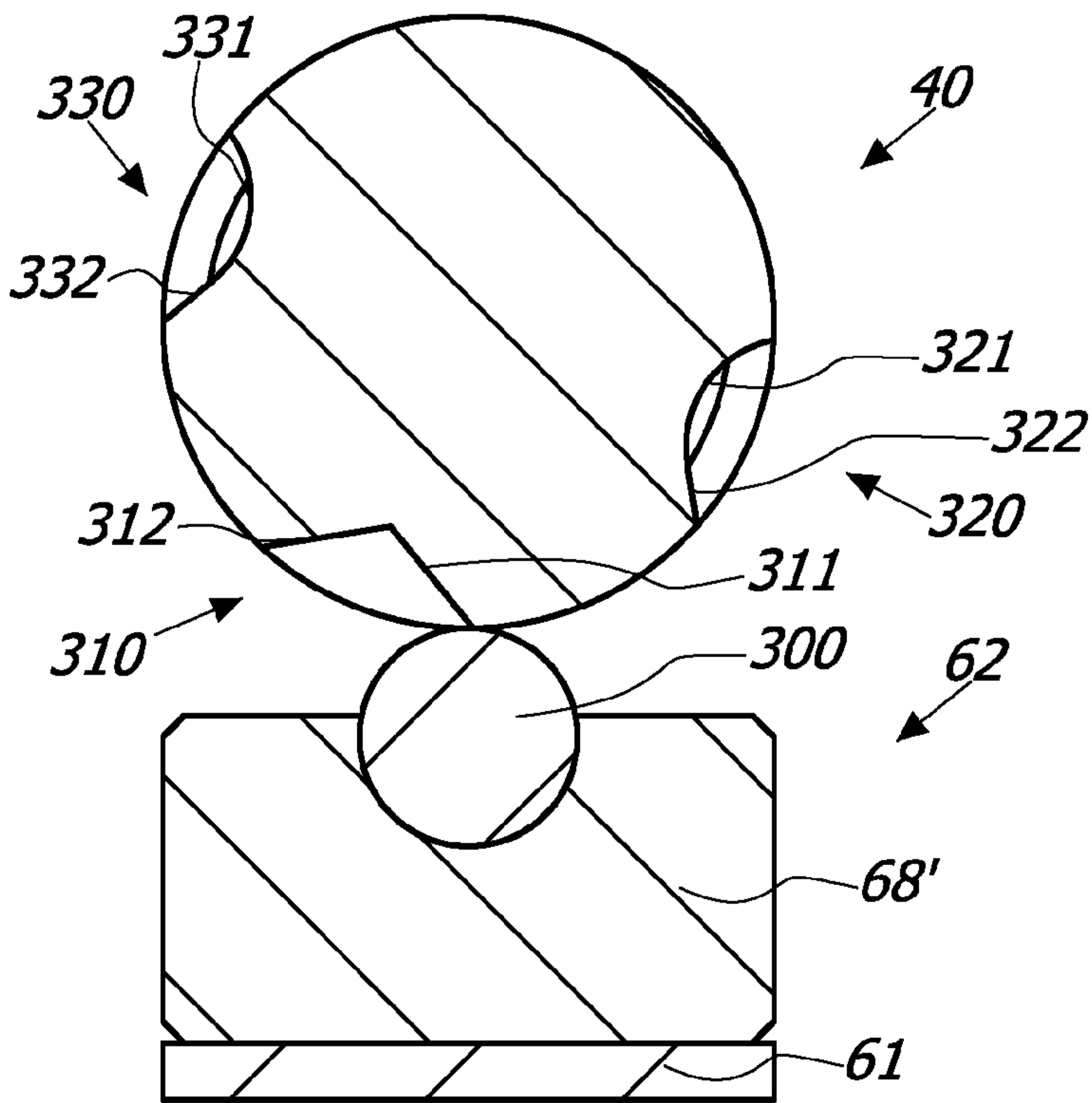

FIG. 15

11 / 12

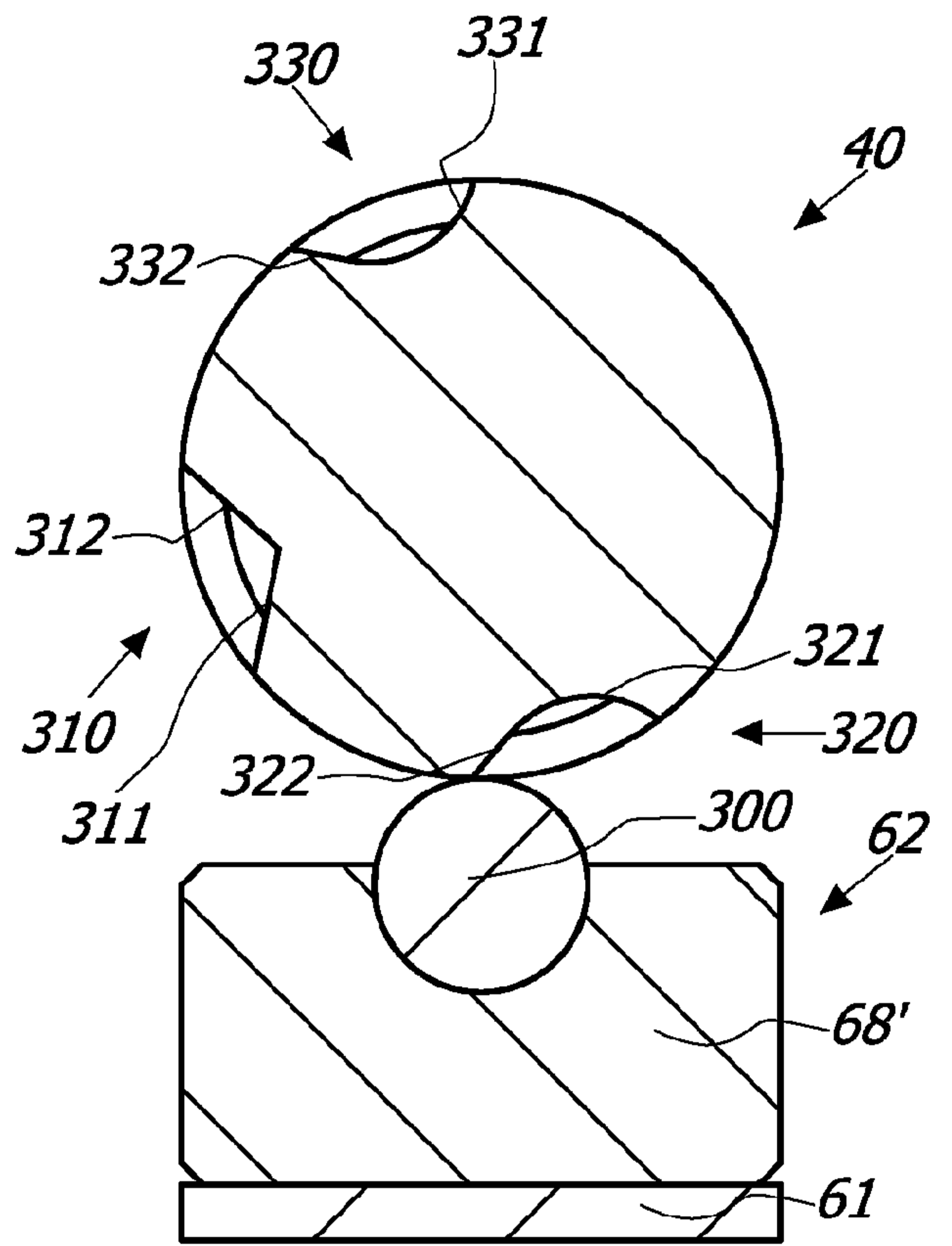

FIG. 16

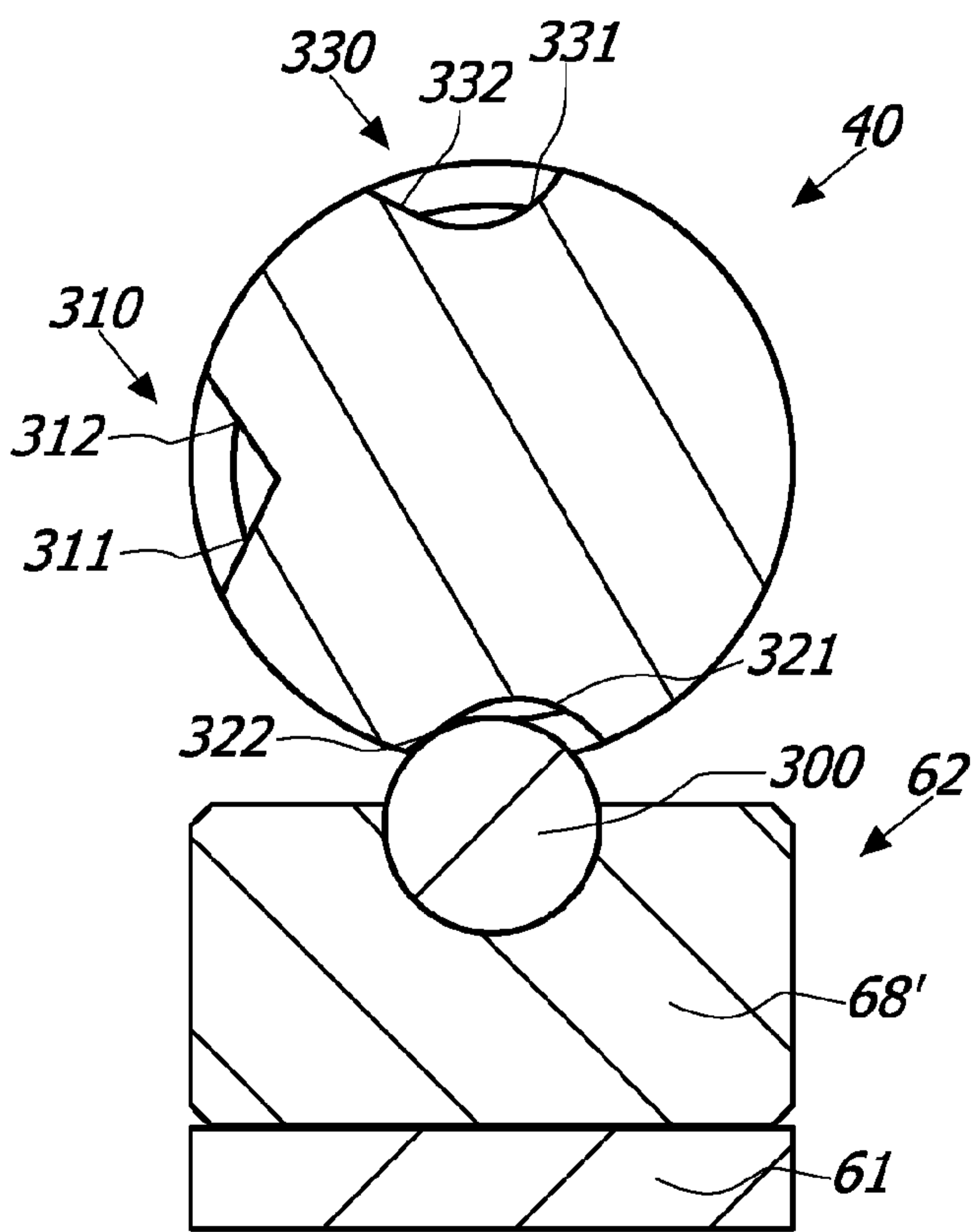

FIG. 17

12 / 12

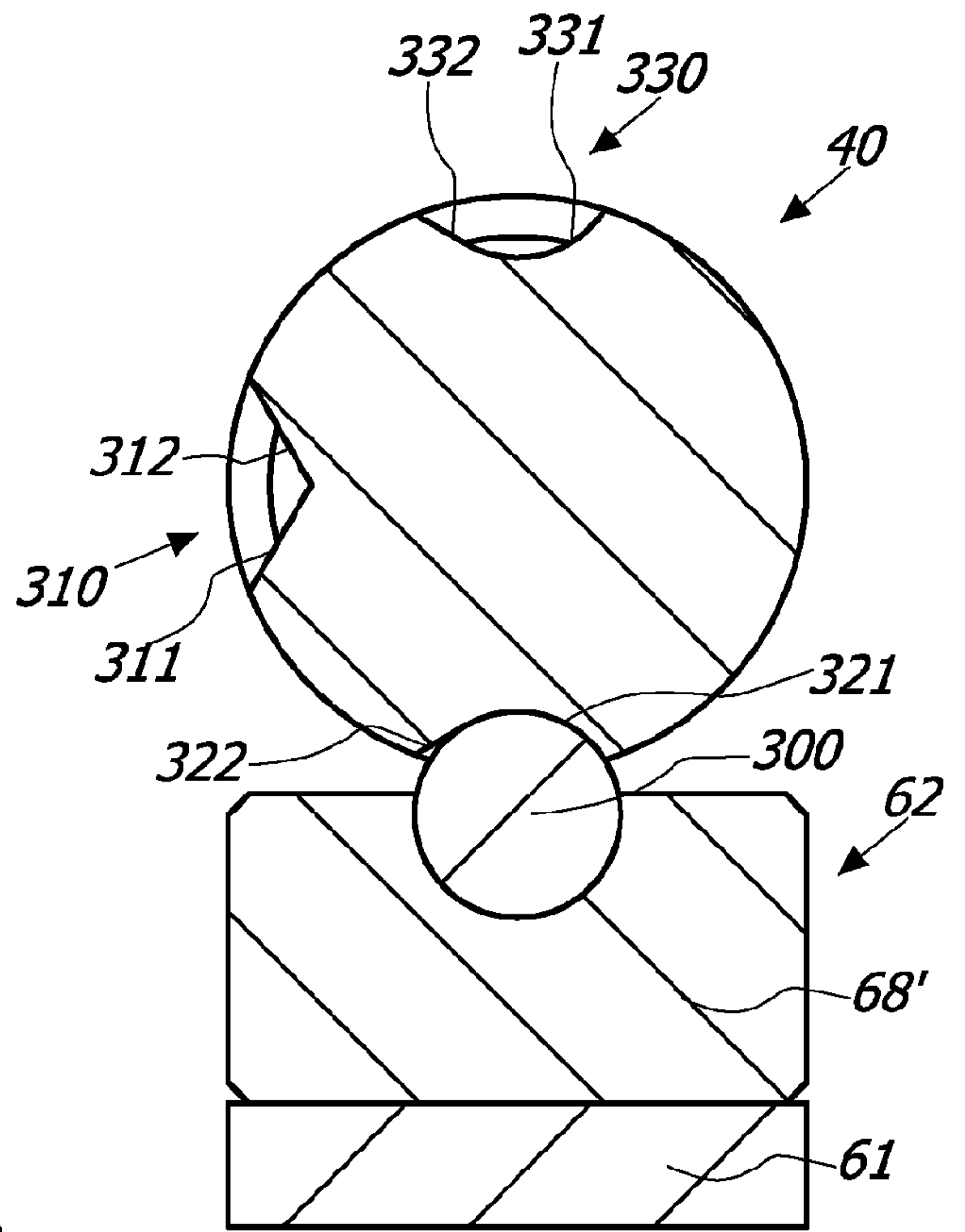

FIG. 18

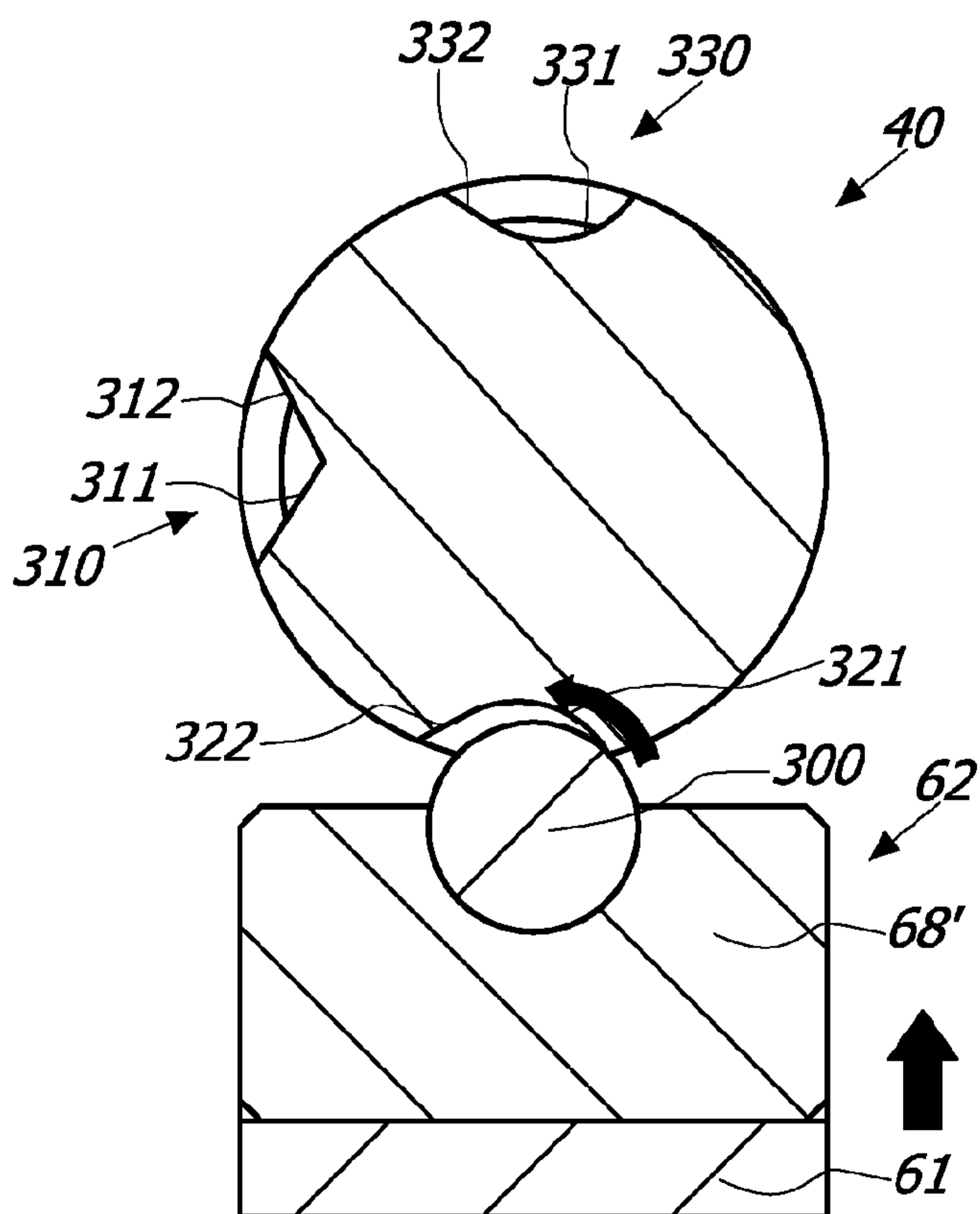

FIG. 19

