



(11) **EP 2 216 449 B1**

(12) **EUROPEAN PATENT SPECIFICATION**

(45) Date of publication and mention of the grant of the patent:
05.08.2020 Bulletin 2020/32

(51) Int Cl.:
E03F 5/04^(2006.01)

(21) Application number: **10152911.3**

(22) Date of filing: **08.02.2010**

(54) **Drain with inspection hole**

Abfluss mit Inspektionsöffnung

Dispositif de drainage avec trou d'inspection

(84) Designated Contracting States:
AT BE BG CH CY CZ DE DK EE ES FI FR GB GR HR HU IE IS IT LI LT LU LV MC MK MT NL NO PL PT RO SE SI SK SM TR

(30) Priority: **10.02.2009 NL 2002511**

(43) Date of publication of application:
11.08.2010 Bulletin 2010/32

(73) Proprietor: **Easy Sanitary Solutions B.V.**
7575 BK Oldenzaal (NL)

(72) Inventor: **Keizers, Jurgen Hendrik Peter Joseph**
7582 GH, Losser (NL)

(74) Representative: **'t Jong, Bastiaan Jacob**
Inaday B.V.
Hengelosestraat 141
7521 AA Enschede (NL)

(56) References cited:
EP-A- 1 577 452 EP-A1- 1 961 879
DE-B- 1 132 507 DE-U1- 7 932 381
GB-A- 2 382 769 GB-A- 190 714 382
GB-A- 191 012 450

EP 2 216 449 B1

Note: Within nine months of the publication of the mention of the grant of the European patent in the European Patent Bulletin, any person may give notice to the European Patent Office of opposition to that patent, in accordance with the Implementing Regulations. Notice of opposition shall not be deemed to have been filed until the opposition fee has been paid. (Art. 99(1) European Patent Convention).

Description

[0001] The invention relates to a drain comprising:

- a first chamber with an inflow opening on the upper side;
- a second chamber placed adjacently of the first chamber, which second chamber is in liquid connection on the underside with the first chamber and wherein an outflow opening is arranged close to the upper side of the second chamber.

[0002] In such prior art drains the two chambers form a siphon or air trap to prevent stench from the outflow opening. It is known that the drain can be disassembled to enable cleaning in such a drain of the outflow opening and the outlet pipe lying therebehind. The removable part of such drains usually comprises a part which can be removed via the inflow opening. This removable part forms a part of the second chamber so that, after removal, access can be gained via the inflow opening to the outflow opening.

[0003] The trend in drains, in particular for shower spaces, is for the inflow opening to become increasingly small and narrow so that the part of the drain visible in the floor becomes increasingly small. The removable part must therefore be correspondingly smaller, whereby the access to the outflow opening becomes increasingly more difficult.

[0004] Particularly in the case of elongate shower drains the trend is for the width of the shower drain to become increasingly small, wherein widths of less than two centimetres are not unusual. In such embodiments the possibility of cleaning and accessing the outflow opening is now not available since there is no good solution for making this possible. GB-A-191012450 discloses a drain according to the preamble of claim 1.

[0005] It is now an object of the invention to provide a drain wherein the above stated drawbacks are obviated as far as possible.

[0006] This object is achieved according to the invention with a drain according to claim 1. At least a top part of the upper side of the second chamber, with a sealable inspection hole arranged therein, lies at substantially the same height as the inflow opening in the upper side of the first chamber.

[0007] Since the top part of the upper side of the second chamber lies at substantially the same height as the inflow opening, the sealable inspection hole lies adjacently of the inflow opening in the invention. The dimensions of the inspection hole are hereby no longer determined by the dimensions of the inflow opening. It is thus possible to design the inflow opening as desired, and good access can simultaneously be obtained via the sealable inspection hole.

[0008] The first chamber comprises an elongate gutter, wherein the inflow opening is formed by the peripheral edge of the elongate gutter. It is not necessary here for

the first chamber to have the same height over the full length of the gutter. The first chamber has a maximum height particularly at the position of the second chamber.

[0009] In another preferred embodiment of the invention an outlet pipe protrudes into the second chamber, which outlet pipe is sealed on the end surface and comprises the outflow opening of the second chamber in the peripheral wall.

[0010] This embodiment has the advantage that a structurally very simple drain results. The outflow opening is preferably arranged in an upward facing part of the peripheral wall.

[0011] In another embodiment an adjusting frame is arranged in the inflow opening. Using this adjusting frame the upper edge of the inflow opening can be made flush with for instance the upper surface of a tile layer on the floor in which the drain is arranged. Because the second chamber is arranged adjacently of the first chamber with inflow opening, the adjusting frame can be recessed at least partially into the first chamber, whereby the height of the first and second chambers can be minimized.

[0012] The adjusting frame preferably extends over the inspection hole. The height of the wholly visible part of the drain can hereby be adjusted to the surrounding floor.

[0013] The invention further comprises a floor with a drain according to the invention arranged therein, wherein the inflow opening and the part with the inspection hole lie substantially flush with the upper surface of the floor.

[0014] In a preferred embodiment of the floor according to the invention the drain lies against a wall and tiles arranged on the wall stand on an edge of the inflow opening. The inflow opening is hereby formed in a shower space in a transition between the floor and a wall, whereby it is substantially concealed from view.

[0015] These and other features of the invention are further elucidated with reference to the accompanying drawings.

Figure 1 shows a perspective view of a first embodiment of a drain according to the invention.

Figure 2 shows a cross-sectional view of the embodiment according to figure 1.

Figure 3 shows a cross-sectional view of a second embodiment according to the invention.

Figure 4 shows a third embodiment not according to the invention.

Figure 5 shows a cross-sectional view of a fourth embodiment according to the invention.

[0016] Figure 1 shows a first embodiment 1 of a drain according to the invention. This drain 1 has an elongate gutter 2 of substantially U-shaped cross-section. This elongate gutter 2 forms the inflow opening for drain 1.

[0017] This elongate gutter 2 forms part of a housing 3. Formed in this housing 3 are a downward hanging baffle 4 and a baffle 5 standing upright from the bottom (see also figure 2). Baffle 4 and housing 3 form a first chamber 6 and baffle 4, baffle 5 and housing 3 form a

second chamber 7.

[0018] First chamber 6 and second chamber 7 are in mutual liquid connection via passage 8 under downward hanging baffle 4. The passage 9 over upright baffle 5 is the outflow opening along which liquid flows into a collection chamber 10, after which it can flow into outlet pipe 11.

[0019] The upper side 12 of housing 3 is partially raised above second chamber 7. Provided in this raised upper side 12 is an inspection hole in which a sealing cap 13 is provided.

[0020] The height of upper side 12 of housing 3 is substantially equal to the height of the inflow opening of elongate gutter 2. When drain 1 is incorporated into a floor, the upper surface of for instance tiles 14 will lie at this same height.

[0021] Figure 3 shows a second embodiment of a drain 20 according to the invention. This drain 20 also has an elongate gutter 21 which forms part of a housing 22. Arranged in housing 22 is a downward hanging baffle 23 whereby housing 22 is divided into a first chamber 24 and a second chamber 25. Upper side 26 of second chamber 25 lies at the same height as the inflow opening of gutter 21. An inspection hole sealed by a sealing cap 27 is again provided in this upper side 26.

[0022] An outlet pipe 28, the end surface 29 of which is sealed, protrudes into second chamber 25. On the upper side of outlet pipe 28 a part of the peripheral wall has been removed so that an outflow opening 30 for second chamber 25 is formed.

[0023] Water W flowing into first chamber 24 via gutter 21 will flow under downward hanging baffle 23 and then flow upward on either side of the outlet pipe 28 protruding into second chamber 25, and subsequently leave drain 20 via outflow opening 30.

[0024] Figure 4 shows a third embodiment 40 not according to the invention. Drain 40 has a housing 41 to which an outlet pipe 42 is coupled. An upright wall 43 is placed in housing 41. A removable wall part 44 further hangs downward from the upper side.

[0025] A first chamber 45 is formed between a side wall of housing 41 and removable wall part 44 and a second chamber 46 is formed between wall part 44 and upright wall 43.

[0026] Upper side 47 of the side wall is bent so that tiles 48 can be placed thereon. Inflow opening 49 of this drain 40 is formed by the bent upper side 47 and removable wall part 44.

[0027] Figure 5 shows a fourth embodiment of a drain 50 according to the invention. This drain 50 resembles drain 20 according to figure 3. The same parts are therefore designated with the same reference numerals.

[0028] An elongate gutter 21 forming part of housing 22 is also provided in this drain 50. Arranged in this housing is a downward hanging baffle 23 whereby the housing is divided into a first chamber 24 and a second chamber 25.

[0029] An outlet pipe 28 likewise protrudes into second

chamber 25 in the same manner as shown in figure 3. Outlet pipe 28 of drain 50 is short and suitable for coupling to a subsequent outlet pipe 51. The seal between outlet pipe 28 and outlet pipe 51 is ensured by a sealing ring 52.

[0030] An adjusting frame 53 is arranged in gutter 21 of drain 50. This adjusting frame 53 can be adjusted in both horizontal and vertical direction. It is hereby possible to allow the visible adjusting frame 53 to connect to floor tiles 54 and wall tiles 55.

[0031] Adjusting frame 53 has a part 56 which extends over the upper side 26 of second chamber 25. A cover 57 concealing sealing cap 27 in the inspection hole from view can be placed on this part 56.

Claims

1. Drain (1; 20; 50), comprising:

- a first chamber (6; 24) with an inflow opening (2; 21) on the upper side;
 - a second chamber (7; 25) placed adjacently of the first chamber (6; 24), which second chamber (7; 25) is in liquid connection on the underside (8) with the first chamber (6; 24) and wherein an outflow opening (9; 30) is arranged close to the upper side of the second chamber (7; 25), wherein at least a top part of the upper side (12; 26) of the second chamber (7; 25), with a sealable inspection hole (13; 27) arranged therein, lies at substantially the same height as the inflow opening (2; 21) in the upper side of the first chamber (6; 24), wherein the inspection hole (13; 27) is arranged adjacent and outside of the inflow opening (2; 21),
- characterized in that** the first chamber (6; 24) comprises an elongate gutter (2), wherein the inflow opening (2; 21) is formed by the peripheral edge of the elongate gutter (2).

2. Drain (20; 50) as claimed in claim 1, wherein an outlet pipe (28) protrudes into the second chamber (25), which outlet pipe (28) is sealed on the end surface (29) and comprises the outflow opening (30) of the second chamber (25) in the peripheral wall.

3. Drain (20; 50) as claimed in claim 2, wherein the outflow opening (30) is arranged in an upward facing part of the peripheral wall.

4. Drain (50) as claimed in any of the foregoing claims, wherein an adjusting frame (53) is arranged in the inflow opening (21).

5. Drain (50) as claimed in claim 4, wherein the adjusting frame (53) extends over the inspection hole (27).

6. Floor with a drain (1; 20; 50) as claimed in any of the

foregoing claims arranged therein, wherein the inflow opening (2; 21) and the part with the inspection hole (13; 27) lie substantially flush with the upper surface of the floor (14; 54).

7. Floor as claimed in claim 6, wherein the drain (50) lies against a wall and wherein tiles (55) arranged on the wall stand on an edge of the inflow opening.

Patentansprüche

1. Abfluss (1; 20; 50), umfassend:

- eine erste Kammer (6; 24) mit einer Einströmöffnung (2; 21) an der oberen Seite;
 - eine zweite Kammer (7; 25), die angrenzend zu der ersten Kammer (6; 24) positioniert ist, wobei die zweite Kammer (7; 25) an der Unterseite (8) in Flüssigkeitsverbindung mit der ersten Kammer (6; 24) steht und wobei eine Ausströmöffnung (9; 30) nah zu der oberen Seite der zweiten Kammer (7; 25) angeordnet ist, wobei mindestens ein oberer Teil der oberen Seite (12; 26) der zweiten Kammer (7; 25) mit einem verschließbaren Inspektionsloch (13; 27) darin angeordnet auf im Wesentlichen der gleichen Höhe liegt wie die Einströmöffnung (2; 21) in der oberen Seite der ersten Kammer (6; 24), wobei das Inspektionsloch (13; 27) angrenzend und außerhalb der Einströmöffnung (2; 21) angeordnet ist,
dadurch gekennzeichnet, dass
 die erste Kammer (6; 24) eine längliche Rinne (2) umfasst, wobei die Einströmöffnung (2; 21) durch den Umfangsrand der länglichen Rinne (2) gebildet ist.

2. Abfluss (20; 50) nach Anspruch 1, wobei ein Auslassrohr (28) in die zweite Kammer (25) vorsteht, wobei das Auslassrohr (28) an der Endfläche (29) verschlossen ist und die Ausströmöffnung (30) der zweiten Kammer (25) in der Umfangswand umfasst.
3. Abfluss (20; 50) nach Anspruch 2, wobei die Ausströmöffnung (30) in einem nach oben zeigenden Teil der Umfangswand angeordnet ist.
4. Abfluss (50) nach einem der vorstehenden Ansprüche, wobei ein Anpassungsrahmen (53) in der Einströmöffnung (21) angeordnet ist.
5. Abfluss (50) nach Anspruch 4, wobei sich der Anpassungsrahmen (53) über das Inspektionsloch (27) erstreckt.
6. Boden mit einem Abfluss (1; 20; 50) nach einem der vorstehenden Ansprüche darin angeordnet, wobei

die Einströmöffnung (2; 21) und der Teil mit dem Inspektionsloch (13; 27) im Wesentlichen fluchtgerecht mit der oberen Fläche des Bodens (14; 54) liegen.

7. Boden nach Anspruch 6, wobei der Abfluss (50) gegen eine Wand liegt und wobei an der Wand angeordnete Fliesen (55) auf einer Kante der Einströmöffnung stehen.

Revendications

1. Avaloir (1 ; 20 ; 50), comprenant :

- une première chambre (6 ; 24) avec une ouverture de débit entrant (2 ; 21) sur le côté supérieur ;
 - une seconde chambre (7 ; 25) placée de façon adjacente à la première chambre (6 ; 24), laquelle seconde chambre (7 ; 25) est en raccordement liquide sur la face inférieure (8) avec la première chambre (6 ; 24) et dans lequel une ouverture de débit sortant (9 ; 30) est agencée près du côté supérieur de la seconde chambre (7 ; 25), dans lequel au moins une partie haute du côté supérieur (12 ; 26) de la seconde chambre (7 ; 25), avec un trou de visite étanchéifiable (13 ; 27) agencé à l'intérieur, se trouve sensiblement à la même hauteur que l'ouverture de débit entrant (2 ; 21) dans le côté supérieur de la première chambre (6 ; 24), dans lequel le trou de visite (13 ; 27) est agencé adjacent et extérieur à l'ouverture de débit entrant (2 ; 21),
caractérisé en ce que la première chambre (6 ; 24) comprend une rigole allongée (2), dans lequel l'ouverture de débit entrant (2 ; 21) est formée par le bord périphérique de la rigole allongée (2).

2. Avaloir (20 ; 50) selon la revendication 1, dans lequel un tuyau de sortie (28) dépasse dans la seconde chambre (25), lequel tuyau de sortie (28) est étanchéifié sur la surface d'extrémité (29) et comprend l'ouverture de débit sortant (30) de la seconde chambre (25) dans la paroi périphérique.
3. Avaloir (20 ; 50) selon la revendication 2, dans lequel l'ouverture de débit sortant (30) est agencée dans une partie tournée vers le haut de la paroi périphérique.
4. Avaloir (50) selon l'une quelconque des revendications précédentes, dans lequel un cadre d'ajustement (53) est agencé dans l'ouverture de débit entrant (21).

5. Avaloir (50) selon la revendication 4, dans lequel le cadre d'ajustement (53) s'étend sur le trou de visite (27). 5
6. Sol avec un avaloir (1 ; 20 ; 50) selon l'une quelconque des revendications précédentes, agencé à l'intérieur, dans lequel l'ouverture de débit entrant (2 ; 21) et la partie avec le trou de visite (13 ; 27) se trouvent sensiblement au même niveau que la surface supérieure du sol (14 ; 54). 10
7. Sol selon la revendication 6, dans lequel l'avaloir (50) se trouve contre un mur et dans lequel des carreaux (55) agencés sur le mur se tiennent sur un bord de l'ouverture de débit entrant. 15

20

25

30

35

40

45

50

55

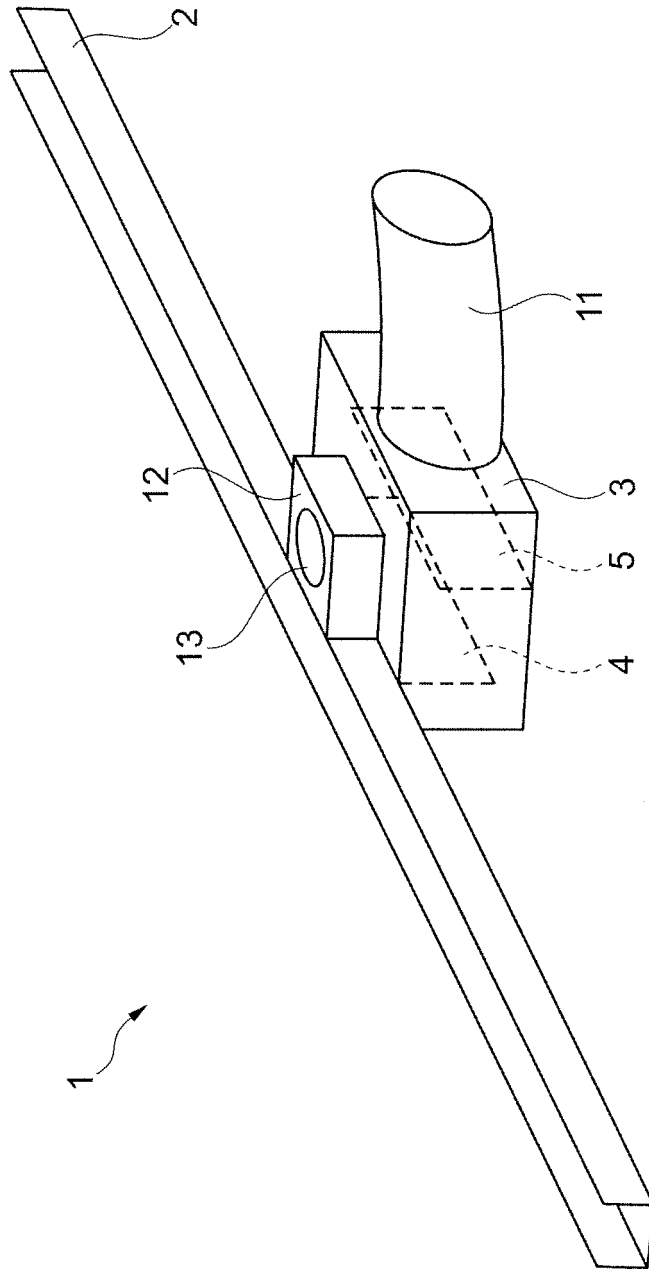

Fig. 1

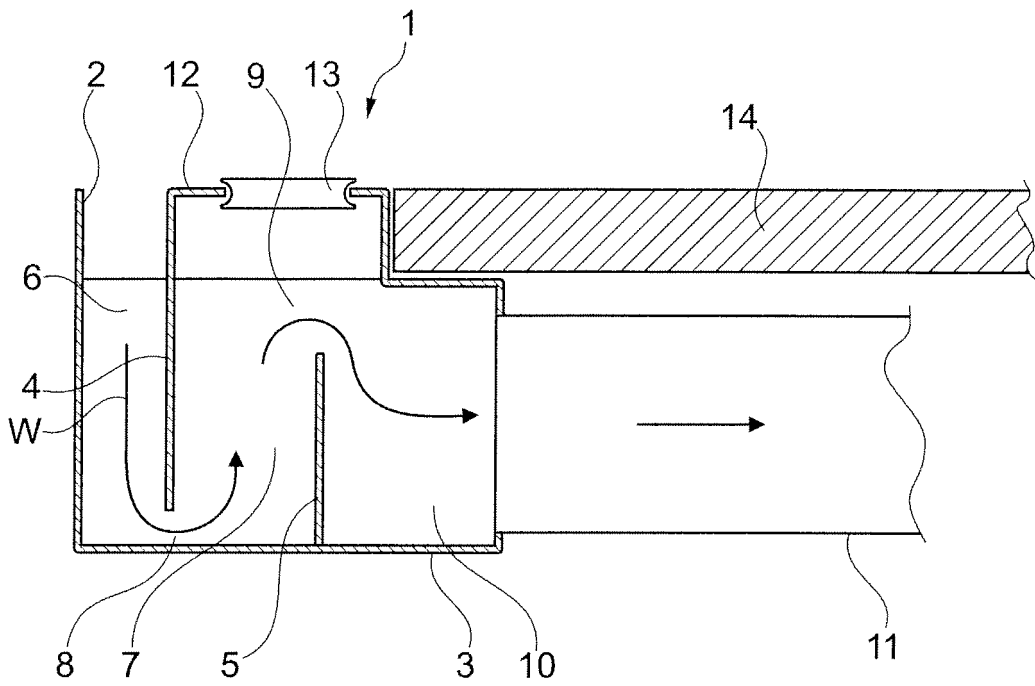

Fig. 2

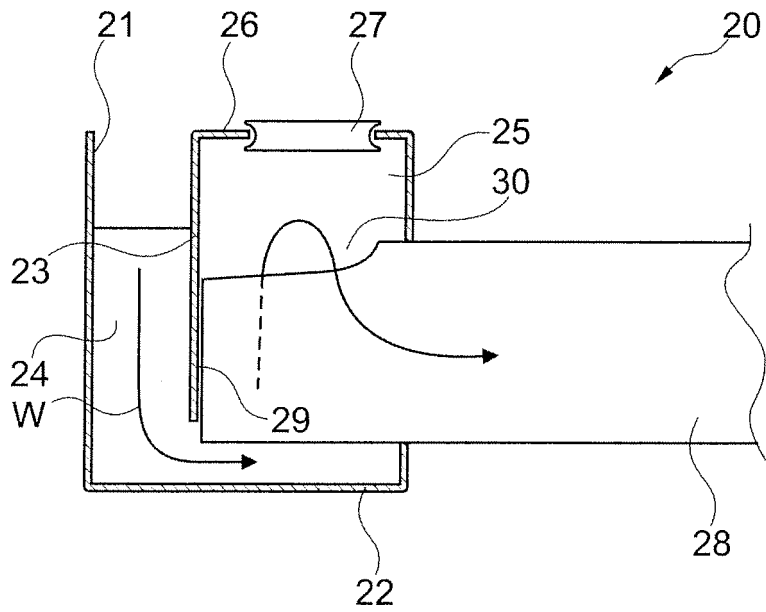

Fig. 3

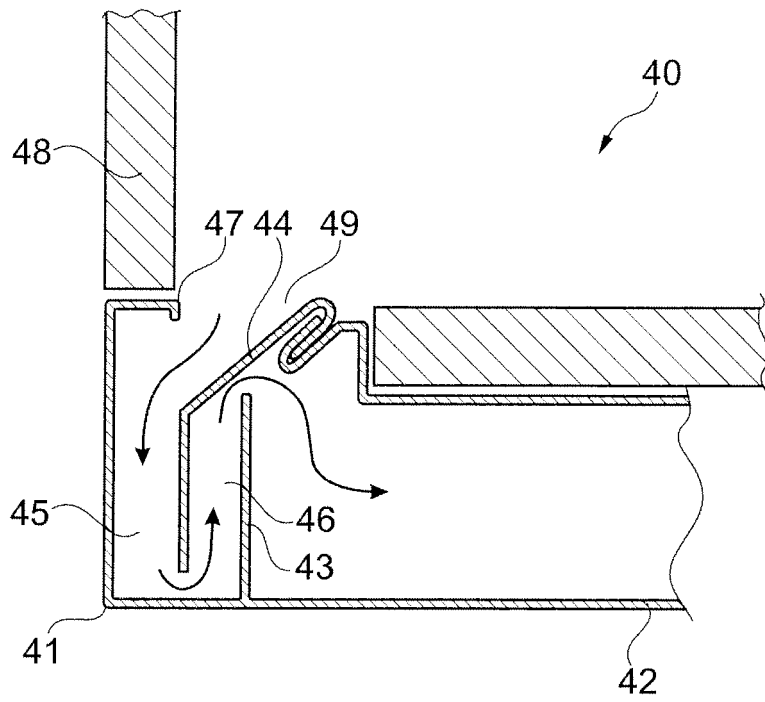

Fig. 4

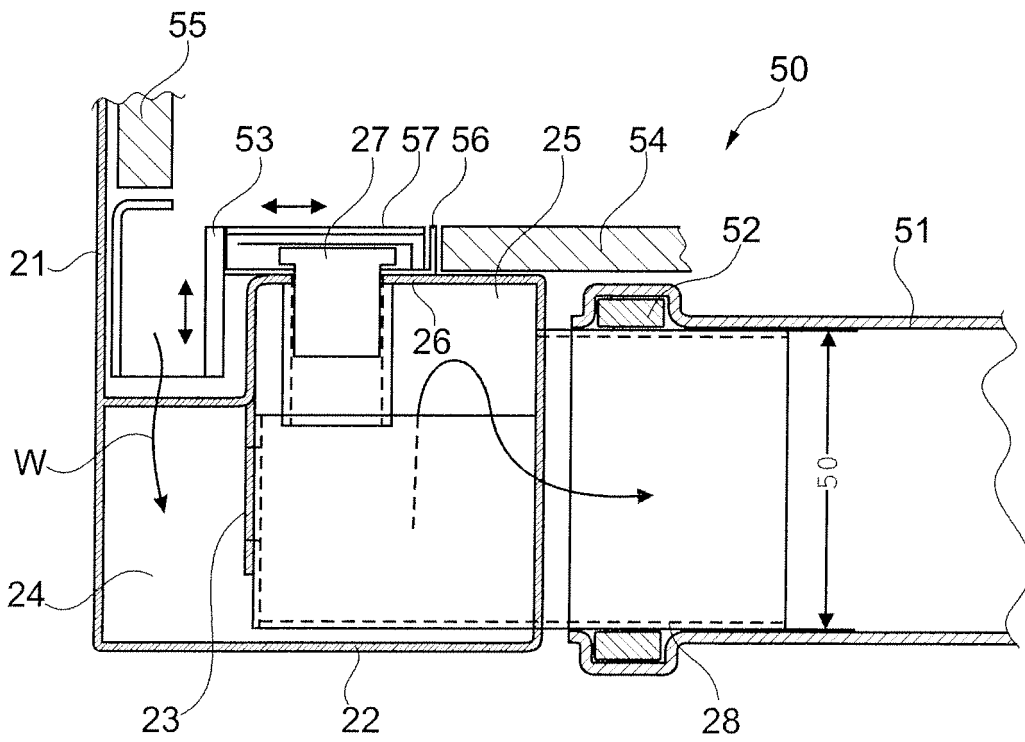

Fig. 5

REFERENCES CITED IN THE DESCRIPTION

This list of references cited by the applicant is for the reader's convenience only. It does not form part of the European patent document. Even though great care has been taken in compiling the references, errors or omissions cannot be excluded and the EPO disclaims all liability in this regard.

Patent documents cited in the description

- GB 191012450 A [0004]