



- (51) International Patent Classification:
B64C 1/14 (2006.01) *B64D 11/00* (2006.01)
- (21) International Application Number:
PCT/EP2012/068908
- (22) International Filing Date:
26 September 2012 (26.09.2012)
- (25) Filing Language: English
- (26) Publication Language: English
- (30) Priority Data:
10 2011 083 810.4
30 September 2011 (30.09.2011) DE
61/541,498 30 September 2011 (30.09.2011) US
- (71) Applicant (for all designated States except US): **AIRBUS OPERATIONS GMBH** [DE/DE]; Kreetstag 10, 21129 Hamburg (DE).
- (72) Inventors; and
(71) Applicants (for US only): **BAUER, Hans-Achim** [DE/DE]; Elversweg 79A, 21037 Hamburg (DE). **ZYBALA, Andre** [DE/DE]; Am Pellerbruch 16, 21271 Hanstedt (DE).
- (74) Agent: **PECKMANN, Ralf**; Friedrichstrasse 31, 80801 München (DE).

- (81) Designated States (unless otherwise indicated, for every kind of national protection available): AE, AG, AL, AM, AO, AT, AU, AZ, BA, BB, BG, BH, BN, BR, BW, BY, BZ, CA, CH, CL, CN, CO, CR, CU, CZ, DE, DK, DM, DO, DZ, EC, EE, EG, ES, FI, GB, GD, GE, GH, GM, GT, HN, HR, HU, ID, IL, IN, IS, JP, KE, KG, KM, KN, KP, KR, KZ, LA, LC, LK, LR, LS, LT, LU, LY, MA, MD, ME, MG, MK, MN, MW, MX, MY, MZ, NA, NG, NI, NO, NZ, OM, PA, PE, PG, PH, PL, PT, QA, RO, RS, RU, RW, SC, SD, SE, SG, SK, SL, SM, ST, SV, SY, TH, TJ, TM, TN, TR, TT, TZ, UA, UG, US, UZ, VC, VN, ZA, ZM, ZW.
- (84) Designated States (unless otherwise indicated, for every kind of regional protection available): ARIPO (BW, GH, GM, KE, LR, LS, MW, MZ, NA, RW, SD, SL, SZ, TZ, UG, ZM, ZW), Eurasian (AM, AZ, BY, KG, KZ, RU, TJ, TM), European (AL, AT, BE, BG, CH, CY, CZ, DE, DK, EE, ES, FI, FR, GB, GR, HR, HU, IE, IS, IT, LT, LU, LV, MC, MK, MT, NL, NO, PL, PT, RO, RS, SE, SI, SK, SM, TR), OAPI (BF, BJ, CF, CG, CI, CM, GA, GN, GQ, GW, ML, MR, NE, SN, TD, TG).

Published:

— with international search report (Art. 21(3))

(54) Title: WINDOW MODULE FOR AN AIRCRAFT OR SPACECRAFT

Fig. 1

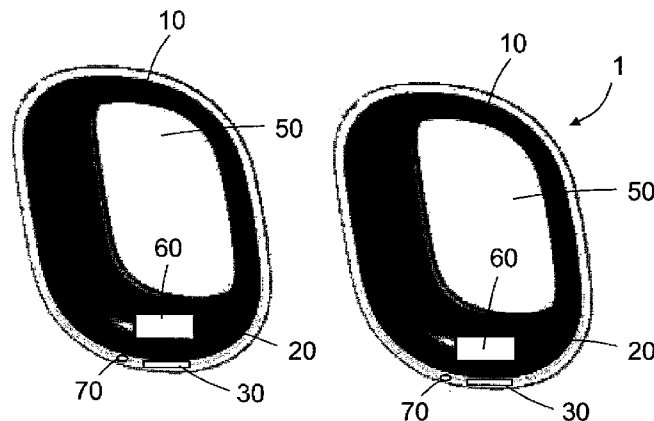

(57) Abstract: The present invention provides a window module for an aircraft or spacecraft, comprising a window frame (10) which comprises, at least in portions, a current-generating element (20) for generating an electric current.

5

Window module for an aircraft or spacecraft

10 The present invention relates to a window module for an aircraft or spacecraft.

15 Although applicable to any window modules in an aircraft or spacecraft, the present invention and the problem on which it is based will be explained in detail with reference to an aircraft.

20 In the aircraft cabin, there is usually the possibility to provide passengers with the opportunity to charge electronic devices at their seat through the electrical on-board network. For this purpose, there is a universal socket at the seat which provides a voltage of 110 V. This socket is configured in such a way that it is suitable for the operation of laptops having a power of approximately 50-70 W. Connecting said socket to the electrical on-board network of the aircraft requires wiring of the seat, whereby, when
25 exchanging the seat or changing the seat configuration in the aircraft cabin, all of the cable connections have to be disconnected and then reconnected again.

30 Furthermore, in recent years laptops have begun to be increasingly replaced by tablet PCs, such as the iPad, or by smartphones. This category of high-powered but energy-saving devices is referred to as what are known as personal electronic devices (PEDs).

35

From the prior art according to DE 10 2005 002 545 A1, an energy buffer device in an aircraft is known, by means of

which electronic devices, which are usually only in operation for a short amount of time, can be operated independently. However, this is disadvantageous in that the energy buffer device has to be connected via the electrical on-board
5 network of the aircraft for charging its energy storage unit, whereby a cable connection is required for connecting to the electrical on-board network.

Furthermore, from the prior art according to DE 10 2005 046
10 729 A1, an energy supply system is known in which energy is supplied to an electrical consumer via a fuel cell. However, this is disadvantageous in that an energy supply system of this type can in turn be used as a central system for providing electrical energy for the electrical on-board
15 network, which has to be connected to the seats in the aircraft cabin via cables in a known manner.

It is therefore the object of the present invention to provide a device for charging or electrically operating
20 electronic devices for an aircraft or a spacecraft, which device can be easily retrofitted or exchanged independently of the electrical on-board network.

According to the invention, this object is achieved by the
25 window module having the features of claim 1.

According thereto, a window module comprising a window frame is provided, which window frame comprises a current-
generating element for generating an electric current.
30

The idea on which the present invention is based consists in using the hitherto unused region of the window frame for generating electric current and using this for charging and/or operating an electronic device, whereby the burden on
35 the electrical on-board network of the aircraft is relieved. In particular, the incident sunlight and/or the light from

the cabin illumination system can be used for generating the electric current.

5 An advantage of the present invention is that the present window module provides an energy source for electronic devices having a low electrical power, which energy source is independent of the aircraft infrastructure and therefore is not connected to the electrical on-board network of the aircraft. In addition, the cable connection at the seat for
10 connecting to the electrical on-board network can advantageously be omitted, whereby refitting seats in another seat arrangement or exchanging seats is made easier.

Furthermore, the present invention advantageously allows the
15 associated control electronics for the current-generating element to be integrated into the region of the aircraft inner lining, which at the same time is a component of the window module. Existing window modules can therefore easily be exchanged for the present window module.

20 Advantageous configurations and improvements of the invention are set out in the dependent claims.

According to a preferred configuration, the current-
25 generating element is arranged in the region of the inner surface of the window frame. The largest possible region for generating electric current can therefore be exploited for the arrangement of the current-generating element.

30 According to a further preferred configuration, the current-generating element generates the electric current by means of a photoelectric element. The current-generating element can therefore for example be a solar cell which can generate the electric current cost-effectively during the flight.

35 According to a further preferred configuration, the current-generating element is a polymeric organic solar cell. A solar

cell of this type can be imprinted on the window frame of the window module and has a very low thickness. At the same time, the polymeric organic solar cell can cover substantially the entire inner surface of the window frame, whereby a maximum possible region for generating the electric current is available.

According to a further preferred configuration, the geometric configuration of the current-generating element is substantially identical to the geometric configuration of the associated underlying region of the window frame. Owing to this, the shape of the current-generating element can follow the shape of the associated region of the window frame and regions having a curved geometry can therefore be covered by the current-generating element and used for generating the electric current.

According to a further preferred configuration, the window module comprises an interface for transmitting the electric current generated by the current-generating element to an electronic device. In this connection, a USB interface is preferably used, which is present on the majority of available PEDs.

According to a further preferred configuration, means for controlling the charging process for the electronic device and/or an electrical storage unit are further provided on the window frame. A charge controller for charging the electronic device can thus preferably be provided, which interrupts charging when the available electric current is too low or prevents the electronic device from overcharging. The electrical storage unit can advantageously bridge a period of time for supplying or charging the electronic device during which a sufficient amount of electric current cannot be made available by the current-generating element.

According to a further preferred configuration, the interface for transmitting the generated electric current is arranged in the lower region of the window frame. The existing charging cable for the electronic device can therefore also
5 be used in the aircraft, while the electronic device can for example be placed on the tray table of the aircraft seat.

According to a further preferred configuration, the window module is of a modular construction, consisting of the
10 individual components. This advantageously means that, in the case of exchanging an existing window module or retrofitting in an existing aircraft, only the window module has to be removed as a modular component, no functional or electrical interfaces to the aircraft infrastructure having to be
15 disconnected, whereby exchange or retrofitting can be carried out rapidly and at little cost.

According to a further preferred configuration, the thickness of the current-generating element is considerably less than
20 the respective thickness of the associated region of the window frame. This advantageously leads to the current-generating element behaving in a resiliently flexible manner owing to its low thickness, in such a way that the shape of the current-generating element can follow the shape of the
25 associated region of the window frame and regions having a curved geometry can therefore also be covered by the current-generating element and used for generating the electric current.

30 According to a further preferred configuration, a window pane is further provided, of which the material properties are selected in such a way that the absorption of the wavelength, which the energy generation in the current-generating element causes, of the light entering during operation is as low as
35 possible. Owing to this, the wavelength available for energy generation in the current-generating element can be converted into electrical energy in the best possible manner.

According to a further preferred configuration, the mechanical interfaces for connecting the window module to the aircraft or spacecraft correspond to the mechanical
5 interfaces which are conventionally used for a window module. The present window module can therefore be retrofitted in existing aircraft at little cost. Furthermore, in this case the existing infrastructure of the aircraft does not have to be altered for the exchange, and therefore cost-effective
10 retrofitting is possible.

According to a further preferred configuration, the current-generating element comprises lenses for focusing and
15 amplifying the incident light. Said lenses are preferably arranged in the region of the outer surface of the current-generating element. Furthermore, the material properties of the lenses are preferably selected in such a way that the absorption of the wavelength, which the energy generation in the current-generating element causes, of the light entering
20 during operation is as low as possible. Owing to this, the wavelength available for energy generation in the current-generating element can be converted into electrical energy in the best possible manner.

25 Furthermore, an aircraft or spacecraft having at least one window module according to the present invention is claimed.

The invention will be describes in detail by way of embodiments with reference to the accompanying figures of the
30 drawings.

In the figures:

Fig. 1 is a perspective view of a window module according to
35 the invention for an aircraft; and

Fig. 2 is a schematic block diagram of a circuit arrangement

for the functional components of the window module according to the invention.

In the figures, like reference numerals denote like or
5 functionally like components, unless indicated otherwise.

Fig. 1 is a perspective view of a window module 1 according to the invention for an aircraft (not shown), which module comprises a window frame 10, a window pane 50 arranged inside
10 the window frame 10 and a current-generating element 20.

The current-generating element 20 is preferably a solar cell which is arranged in the region of the inner surface of the window frame 10. The solar cell covers the region of the
15 inner surface of the window frame 10 at least in portions and is preferably arranged in the region which is illuminated most intensively or for the longest period of time by the sun and/or the cabin illumination system during the flight. This is preferably the lower region of the inner surface of the
20 window frame 10. Furthermore, a plurality of solar cells is preferably arranged in the region of the inner surface of the window frame 10 in such a way that as high an electrical power as possible can be made available for electrically supplying the electronic device to be charged.

25 In addition, the window module 1 can also comprise an electrical storage unit (not shown) which receives the electrical energy generated by the solar cell and stores it until the next time the electronic device is charged.

30 Furthermore, the window frame 10 comprises, in the region of the outer surface thereof, an interface 30 for transmitting the electric current generated by the solar cell to the electronic device. The interface 30 is preferably a
35 standardised interface, such as a USB interface, which lends itself in particular to PEDs. In the region next to the interface 30, an indicator light 70 is arranged on the window

frame 10 and visually indicates to the passenger the occurrence of a fault when the electronic device is being charged or supplied.

5 A charge controller 60 is arranged on the rear face of the window frame 10, is mounted on the window frame 10 and is not visible when the window module 1 is installed in the aircraft cabin since it is covered by the window frame 10. The charge controller 60 controls the charging process for transmitting
10 the electric current generated by the solar cell to the electronic device via the interface 30, taking into account the electrical storage unit if this is provided.

The window module 1 is preferably of a modular construction,
15 consisting of the above-mentioned individual components. Owing to this, an existing window module can be advantageously exchanged for the present window module at little cost, since the mechanical interfaces thereof are identical to those for connecting a conventional window
20 module to the fuselage structure of the aircraft. Furthermore, in the event of a defect in an electronic component of the present window module, the module can simply be removed and selectively replaced with a new window module or the faulty electronic component of the present window
25 module can be replaced.

Fig. 2 is a schematic block diagram of a circuit arrangement for the functional components of the window module according to the invention. A solar cell 20 generates an electric
30 current and provides this to a charge controller 60. The charge controller 60 monitors the current flow to a USB interface 30. The USB interface 30 charges and/or supplies an electronic device (not shown) with electrical energy which is generated by the solar cell 20.

35

The charge controller 60 is further electrically connected to an electrical storage unit 40. If no electronic device to be

charged is connected to the USB interface 30, the electrical energy generated by the solar cell 20 is provided to the electrical storage unit 40 and charges it. In addition, the electrical storage unit 40 absorbs current peaks and can provide an (auxiliary) electric current for charging or supplying the electronic device in a situation in which the solar cell 20 can only generate relatively little electric current due to unfavourable light conditions.

10 Furthermore, an indicator light 70 is provided which is electrically connected to the charge controller 60. The indicator light 70 indicates to a passenger the overall operational availability of the USB interface 30 for charging or supplying the electronic device.

15

The current flow towards the USB interface 30 is monitored by the charge controller 60 when the electronic device is charging. If an overload occurs with respect to the amount of current which is currently required by the electronic device, the USB interface 30 is deactivated and the occurrence of this fault is indicated to the passenger by an associated signal at the indicator light 70. In the event that the window module currently cannot provide enough electric current available for charging the electronic device via the USB interface 30, because for example the solar cell 20 currently is not receiving enough light energy, this is then also indicated to the passenger by means of the indicator light 70.

30 Although the present invention has been described herein on the basis of preferred embodiments, it is not restricted thereto, but can be modified in various ways.

For example, the material properties of the window pane may be selected in such a way that the absorption of the wavelength, which the energy generation in the current-generating element causes, of the light entering during

35

operation is as low as possible.

List of reference numerals

	1	Window module
	10	Window frame
5	20	Current-generating element
	30	Interface
	40	Electrical storage unit
	50	Window pane
	60	Charge controller
10	70	Indicator light

Claims

5

1. Window module for an aircraft or spacecraft, comprising a window frame (10) which comprises, at least in portions, a current-generating element (20) for generating an electric current.

10

2. Window module according to claim 1, characterised in that the current-generating element (20) is arranged in the region of the inner surface of the window frame (10).

15

3. Window module according to either claim 1 or claim 2, characterised in that the current-generating element (20) generates the electric current by means of a photoelectric element.

20

4. Window module according to at least one of the preceding claims, characterised in that the current-generating element (20) is a polymeric organic solar cell.

25

5. Window module according to claim 4, characterised in that the geometric configuration of the current-generating element (20) is substantially identical to the geometric configuration of the associated underlying region of the window frame (10).

30

6. Window module according to at least one of the preceding claims, characterised in that the window module comprises an interface (30) for

35

transmitting the electric current generated by the current-generating element (20) to an electronic device.

7. Window module according to claim 6,
5 characterised in that means (60) for controlling the charging process for the electronic device and/or an electrical storage unit (40) are further provided on the window frame (10).
- 10 8. Window module according to either claim 6 or claim 7, characterised in that the interface (30) for transmitting the generated electric current is arranged in the lower region of the window frame (10).
15
9. Window module according to at least one of the preceding claims,
characterised in that the window module is of a modular construction,
20 consisting of the individual components.
10. Window module according to at least one of the preceding claims,
characterised in that
25 the thickness of the current-generating element (20) is considerably less than the respective thickness of the associated region of the window frame (10).
11. Window module according to at least one of the preceding
30 claims,
characterised in that a window pane (50) is further provided, of which the material properties are selected in such a way that the absorption of the wavelength, which the energy
35 generation in the current-generating element (20) causes, of the light entering during operation is as low as possible.

12. Window module according to at least one of the preceding claims,
characterised in that
the mechanical interfaces for connecting the window
5 module to the aircraft or spacecraft correspond to the
mechanical interfaces which are conventionally used for
a window module.
13. Window module according to at least one of the preceding
10 claims,
characterised in that
the current-generating element (20) comprises lenses for
focusing and amplifying the incident light.
- 15 14. Aircraft or spacecraft having at least one window module
according to at least one of the preceding claims.

1/2

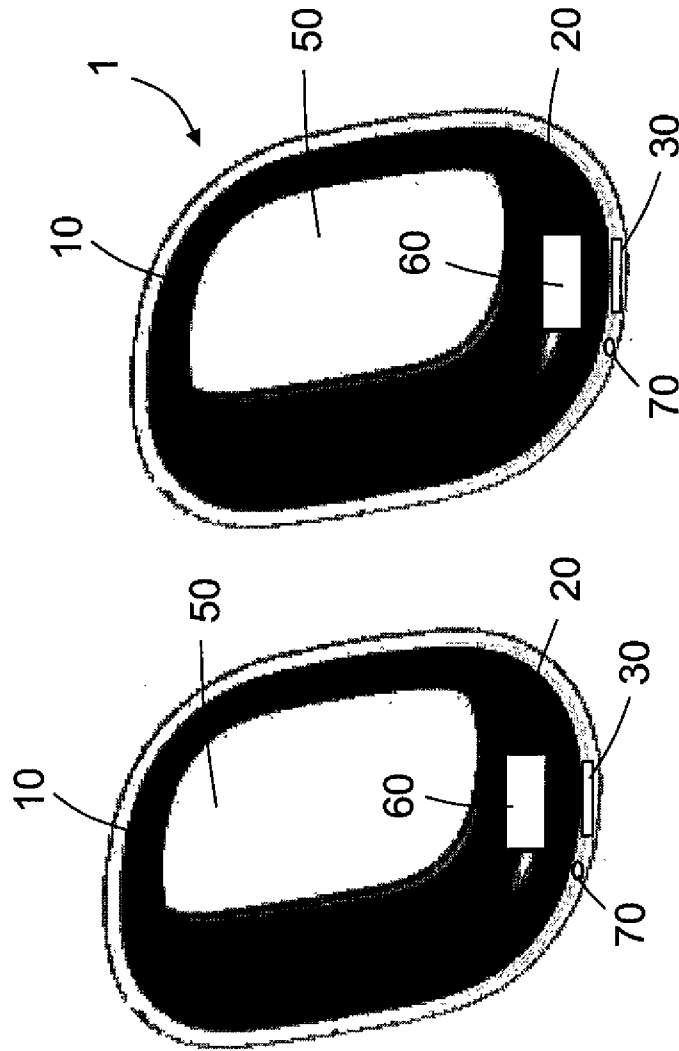

Fig. 1

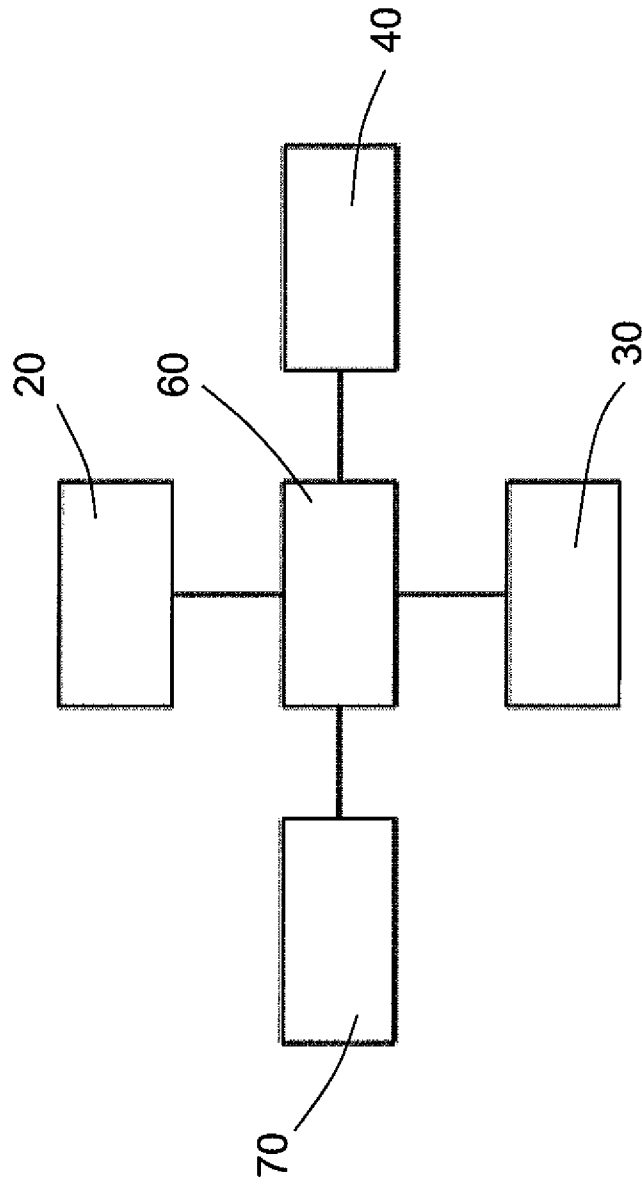

Fig. 2

INTERNATIONAL SEARCH REPORT

International application No
PCT/EP2012/068908

A. CLASSIFICATION OF SUBJECT MATTER
INV. B64C1/14 B64D11/00
ADD.
According to International Patent Classification (IPC) or to both national classification and IPC

B. FIELDS SEARCHED
Minimum documentation searched (classification system followed by classification symbols)
B64C B64D

Documentation searched other than minimum documentation to the extent that such documents are included in the fields searched

Electronic data base consulted during the international search (name of data base and, where practicable, search terms used)
EPO-Internal

C. DOCUMENTS CONSIDERED TO BE RELEVANT

Category*	Citation of document, with indication, where appropriate, of the relevant passages	Relevant to claim No.
A	DE 10 2008 007586 A1 (KRAUTER STEFAN CHRISTOF WERNER [DE]) 6 August 2009 (2009-08-06) abstract paragraph [0004] paragraph [0014] paragraph [0045] paragraph [0046] paragraph [0050] - paragraph [0053] figure	1-14
A	DE 10 2010 000893 A1 (BOSCH GMBH ROBERT [DE]) 21 July 2011 (2011-07-21) abstract figures 1, 2B	1

Further documents are listed in the continuation of Box C.

See patent family annex.

* Special categories of cited documents :

- "A" document defining the general state of the art which is not considered to be of particular relevance
- "E" earlier application or patent but published on or after the international filing date
- "L" document which may throw doubts on priority claim(s) or which is cited to establish the publication date of another citation or other special reason (as specified)
- "O" document referring to an oral disclosure, use, exhibition or other means
- "P" document published prior to the international filing date but later than the priority date claimed

- "T" later document published after the international filing date or priority date and not in conflict with the application but cited to understand the principle or theory underlying the invention
- "X" document of particular relevance; the claimed invention cannot be considered novel or cannot be considered to involve an inventive step when the document is taken alone
- "Y" document of particular relevance; the claimed invention cannot be considered to involve an inventive step when the document is combined with one or more other such documents, such combination being obvious to a person skilled in the art
- "&" document member of the same patent family

Date of the actual completion of the international search 12 December 2012	Date of mailing of the international search report 20/12/2012
---	--

Name and mailing address of the ISA/ European Patent Office, P.B. 5818 Patentlaan 2 NL - 2280 HV Rijswijk Tel. (+31-70) 340-2040, Fax: (+31-70) 340-3016	Authorized officer Estrela Calpe, Jordi
--	--

INTERNATIONAL SEARCH REPORT

Information on patent family members

International application No

PCT/EP2012/068908

Patent document cited in search report	Publication date	Patent family member(s)	Publication date
DE 102008007586 A1	06-08-2009	NONE	
DE 102010000893 A1	21-07-2011	NONE	