



- (72) BUSCH, STEFAN, DE
(72) KRAKENBERG, MANFRED, DE
(72) LERSCH, PETER, DE
(72) STADTMULLER, STEFAN, DE
(71) GOLDSCHMIDT AG, DE
(51) Int.Cl.⁷ C08G 77/46
(30) 1998/11/14 (198 52 621.0) DE
(30) 1999/09/01 (199 41 585.4) DE
(54) **POLYSILOXANES COMPORTANT DES FONCTIONS
POLYETHERS QUATERNAIRES**
(54) **POLYSILOXANES HAVING POLYETHER QUAT FUNCTIONS**

(57) The invention relates to novel polyether-quaternary organosiloxanyl derivatives, to the preparation of these compounds and to their use in formulations for improving the surface properties of fabrics and fibers.

Abstract:

The invention relates to novel polyether-quaternary organosiloxanyl derivatives, to the preparation of these compounds and to their use in formulations for improving the surface properties of fabrics and fibers.

G o l d s c h m i d t AG, Essen

Polysiloxanes having polyether quat functions

5 The invention relates to novel polyether-quaternary organosiloxanyl derivatives, to the preparation of these compounds and to their use in formulations for improving the surface properties of fabrics and fibers.

10 DE 37 19 086 C1 describes quat groups but no polyether fractions. Consequently, the hydrophilicity of the compounds is low.

US 5 098 979 A and US 5 807 956 A describe siloxane
15 polyether quat compounds in which the quaternary ammonium units are attached directly to the polyether.

Polyoxyalkylene-modified silicone copolymers bring about good soft hand and hydrophilicity (US 5 811 482
20 A) on hydrophobic nonwoven surfaces (PE, PP; PE, glass, rayon cellulose, viscose). Applications mentioned include diapers; insoles; paper/fabric cloths for improving the absorbency in conjunction with a pleasant hand. However, no quat groups are present in this case.

25

The invention embraces, in a first embodiment, polysiloxanes having polyether quat functions, of the general formula I

- 2 -

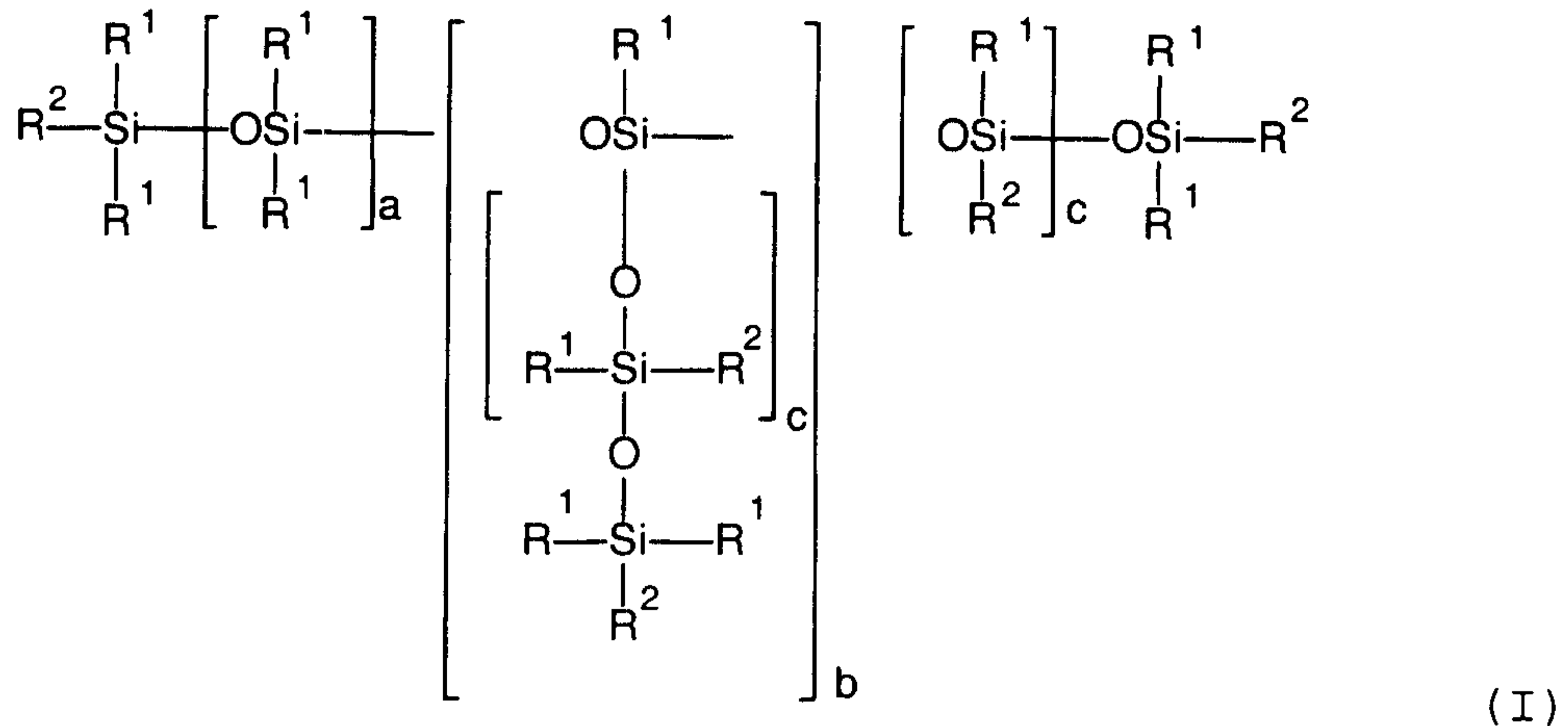

where

a = from 5 to 500,

b = from 0 to 50,

5 c = from 0 to 20,

R^1 = identical or different aliphatic or aromatic carbon radicals of 1 to 8 carbon atoms,

R^2 = R^{2A} or R^{2B} , with the proviso that there is at least one radical R^{2A} and R^{2B} on the siloxane framework,

10 R^{2A} = a polyether radical of the formula II

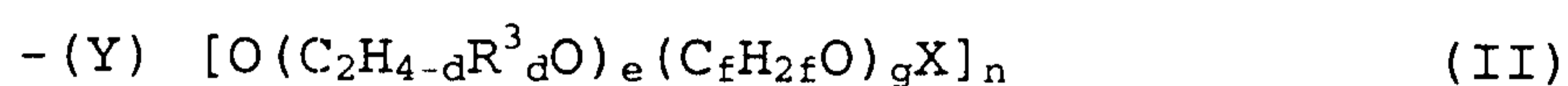

15 where

Y = an $(n + 1)$ -valent, optionally branched hydrocarbon radical,

d = from 1 to 3,

e = from 1 to 20,

20 f = from 2 to 4,

g = from 1 to 20,

X = hydrogen, or a monovalent hydrocarbon radical
or an acyl radical each of 1 to 10 carbon atoms,

n = from 1 to 4,

the radicals R² being identical or different in each

5 case,

R^{2B} = a group -M-Z

where Z is selected from the group consisting of



10

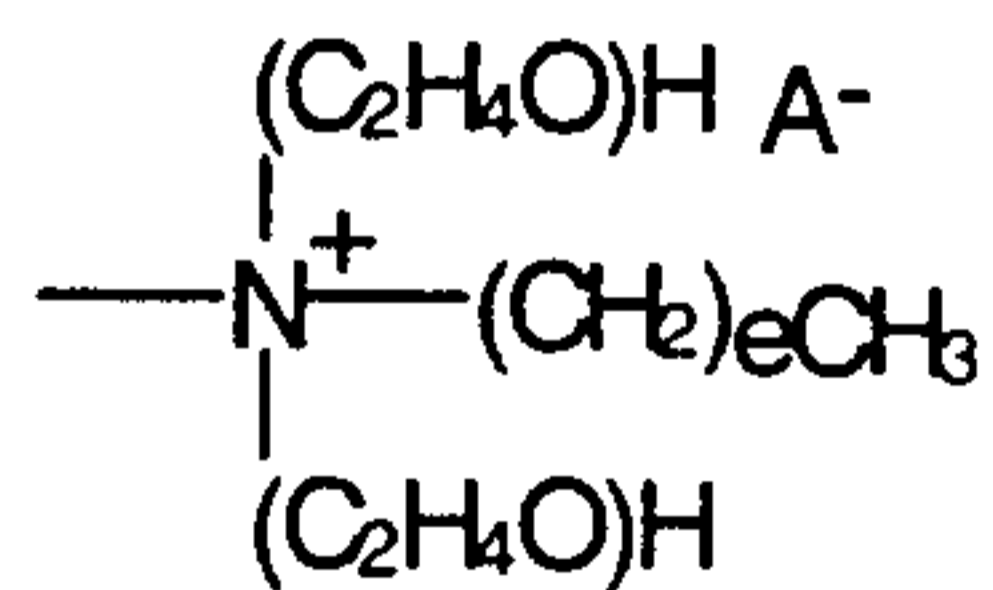

15 R³, R⁴, R⁵, R⁶ = in each case independently of one
another, hydrogen or alkyl of 1 to 22 carbon atoms,

R⁷ = O-; -NR⁹-,

R⁸ = a (n + 1)-valent, optionally branched
hydrocarbon radical, and

20 R⁹ = hydrogen or alkyl or 1 to 6 carbon atoms,

A = a counterion to the positive charges on the quaternized nitrogen groups, selected from organic or inorganic anions of physiologically compatible acids HA,

5

M = a divalent radical selected from the group consisting of

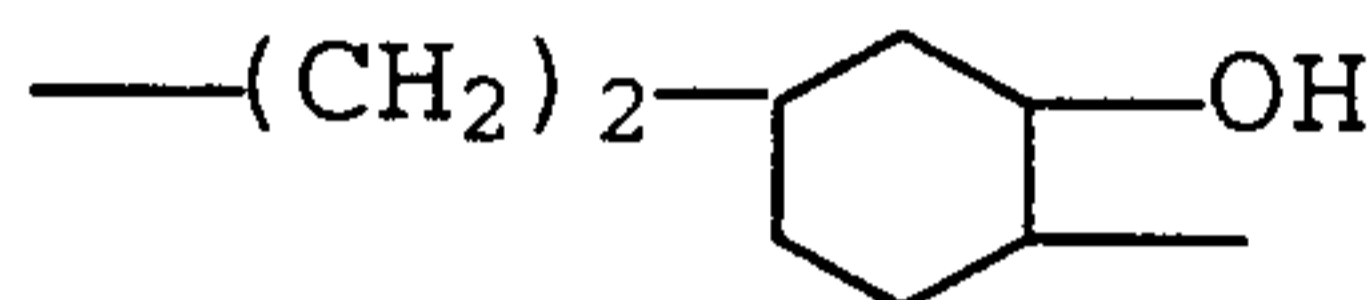
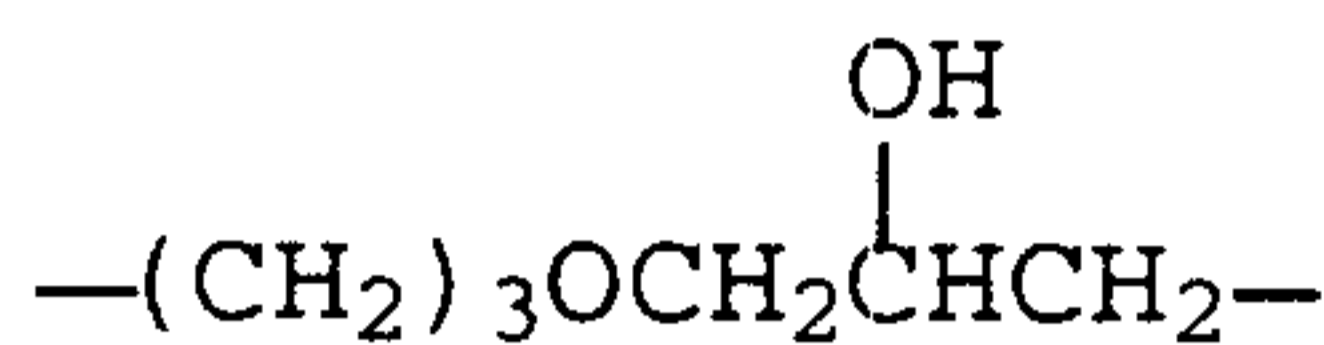

10

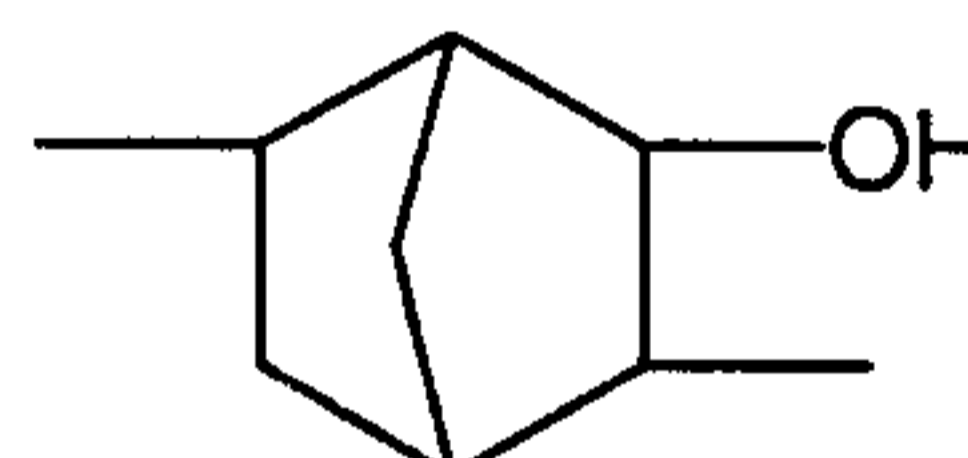
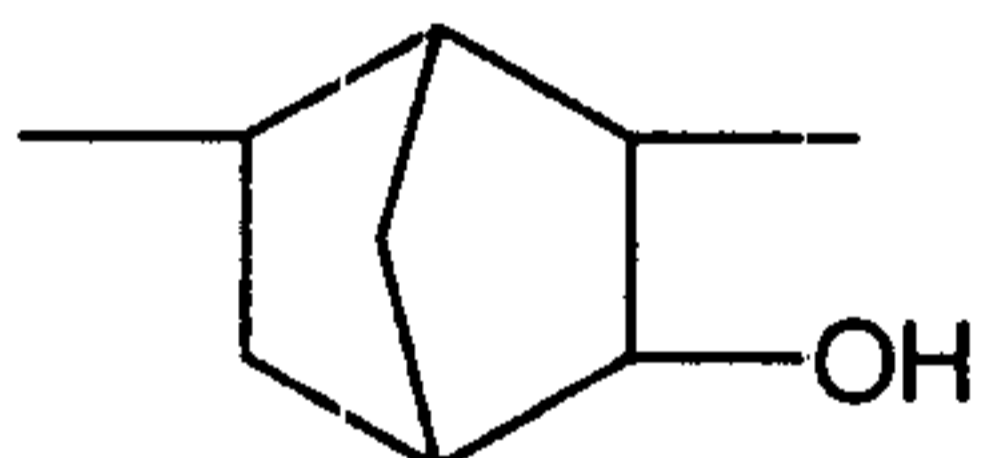
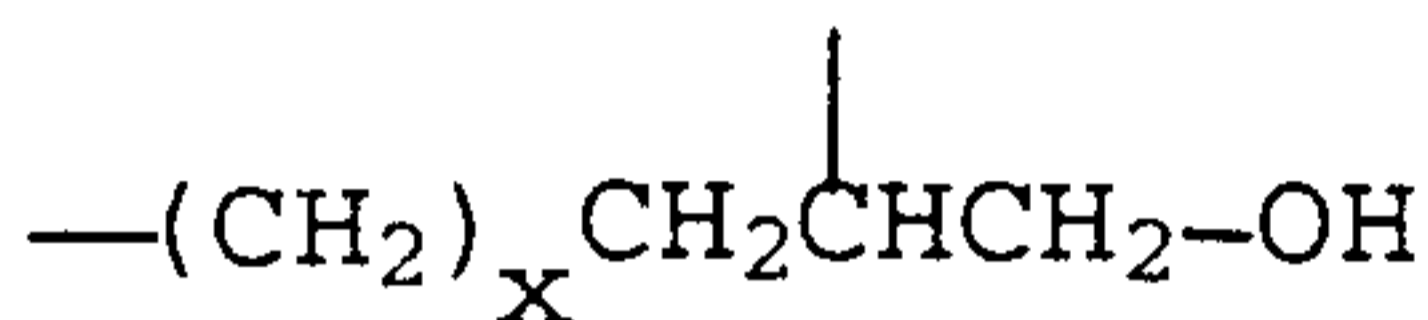
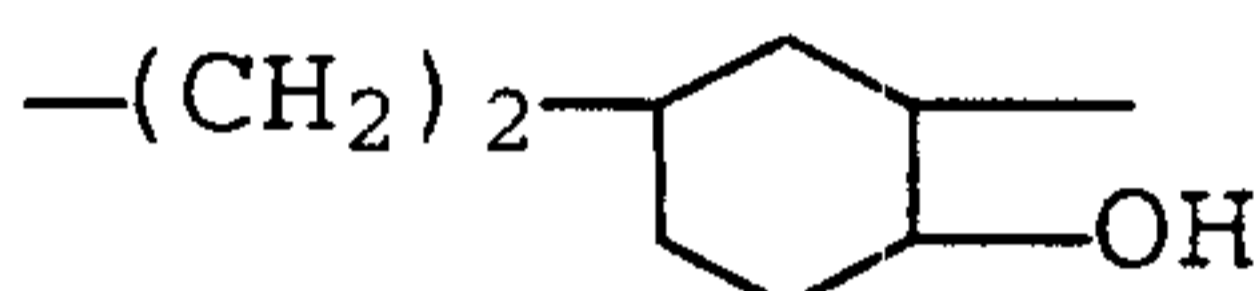
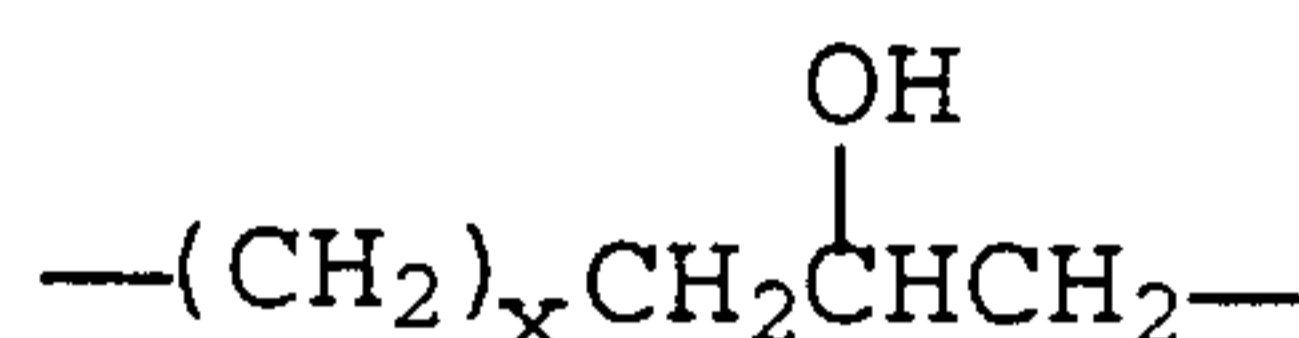
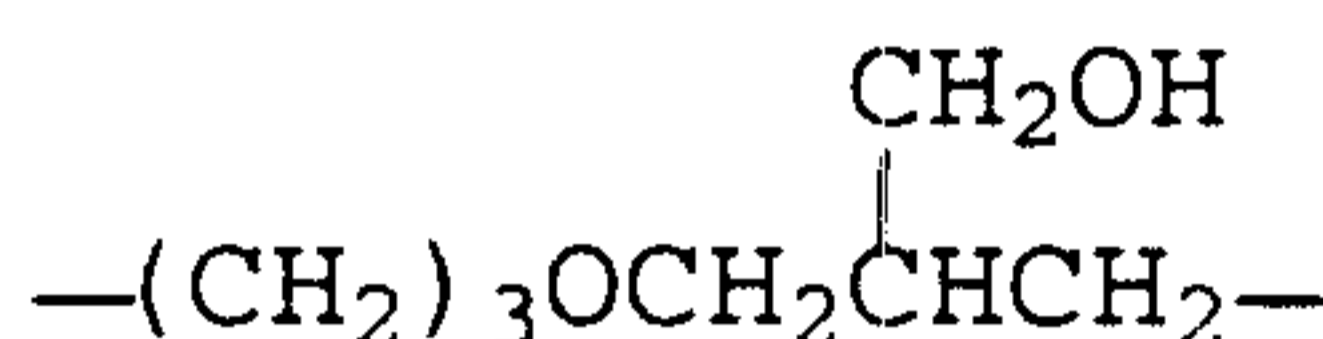

15

Compared with the siloxane quats of the prior art, the polyether siloxane quats of the invention are more hydrophilic and are compatible in a polar environment. They combine the advantages of the individual segments: polyether, quat, and siloxane.

20

For the purposes of the present invention, particular preference is given to siloxanes having polyether quat functions, of the general formula I, in which

a = from 5 to 300,
b = from 0 to 20,
c = from 0 to 5, and
a + b + c \geq 25.

5

If polyether radicals of the general formula II are at issue in the context of the present invention, then the sequence of the propylene oxide radicals and ethylene oxide radicals preferably represents polyether radicals in blockwise mixture.

In a further preferred embodiment of the present invention, the counterion A to the positive charges on the quaternized nitrogen groups consists of the anion of a physiologically compatible acid HA which with particular preference is selected from acetic acid, L-hydroxy carboxylic acids, and aromatic carboxylic acids.

20

Working examples:

Example 1:

25 A 1 l three-necked flask equipped with a stirrer, intensive condenser, thermometer and dropping funnel was charged with 0.1 mol of dimethylaminopropylamine and 45 ml of 2-propanol, and 0.1 mol of acetic acid was added at 20°C. The mixture was allowed to react at 25°C

- 6 -

for 30 minutes and then 0.1 mol of the epoxy polyethersiloxane of the formula

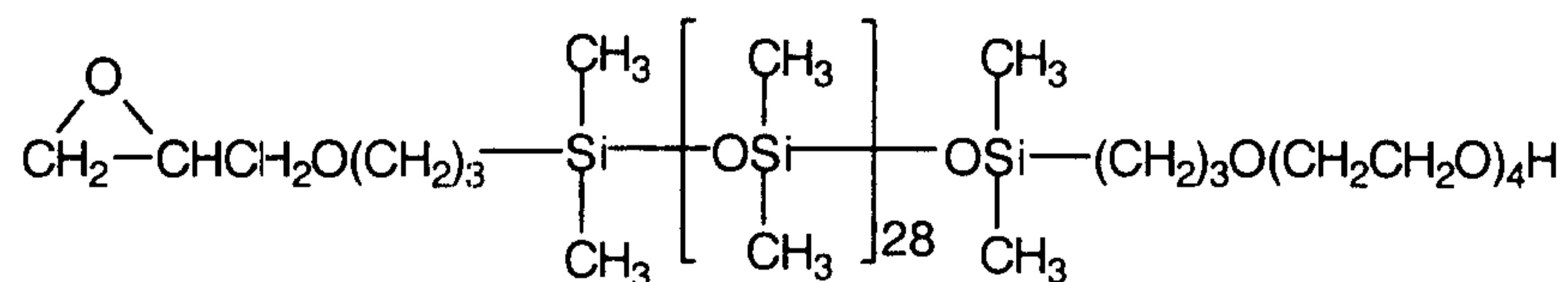

5 was added dropwise. The reaction mixture was first stirred at 25°C for 0.5 h and then heated at 90°C for about 5 h. Subsequently, the solvent was removed by distillation at 90°C and 0.2 bar. The polyethersiloxane quat was obtained as a colorless to pale yellow, oily
10 product. After cooling to room temperature, the product was filtered. According to the results of ²⁹Si-NMR and ¹³C-NMR spectroscopy, the end product has the following structure:

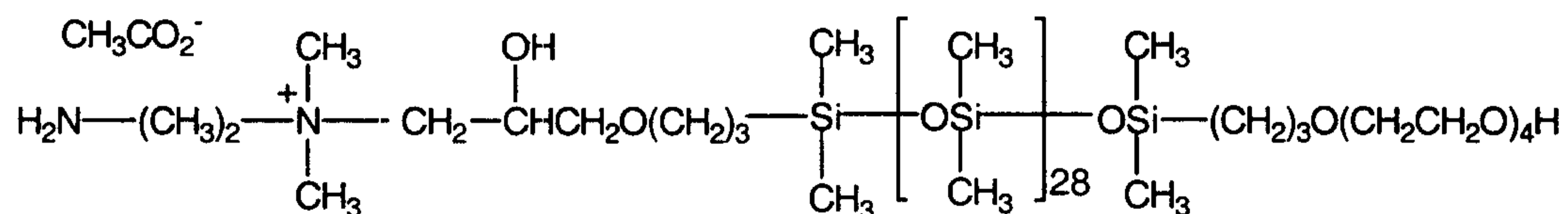

15

Example 2:

A 1 l three-necked flask equipped with a stirrer,
20 intensive condenser, thermometer and dropping funnel was charged with 0.1 mol of dimethylaminopropylamine and 45 ml of 2-propanol, and 0.1 mol of acetic acid was added at 20°C. The mixture was allowed to react at 25°C

for 30 minutes and then 0.1 mol of the epoxy polyethersiloxane of the formula

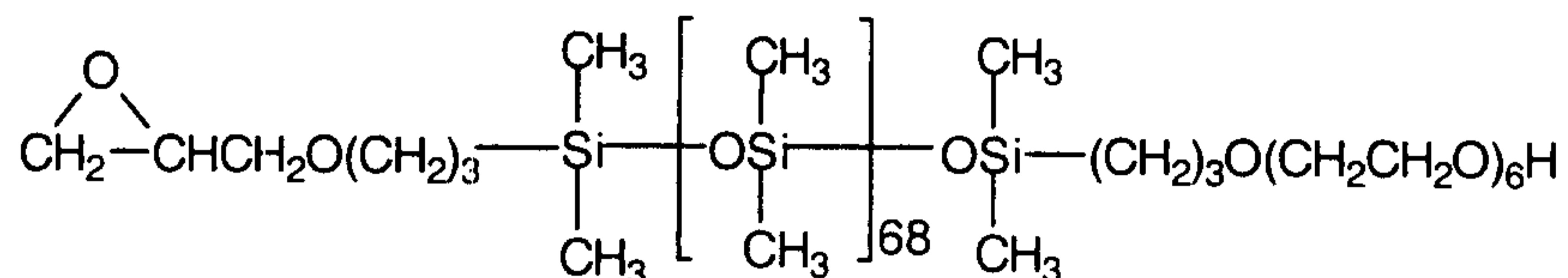

5

was added dropwise. The reaction mixture was first stirred at 25°C for 0.5 h and then heated at 90°C for about 5 h. Subsequently, the solvent was removed by distillation at 90°C and 0.2 bar. The polyethersiloxane quat was obtained as a colorless to pale yellow, oily product. After cooling to room temperature, the product was filtered. According to the results of ²⁹Si-NMR and ¹³C-NMR spectroscopy, the end product has the following structure:

15

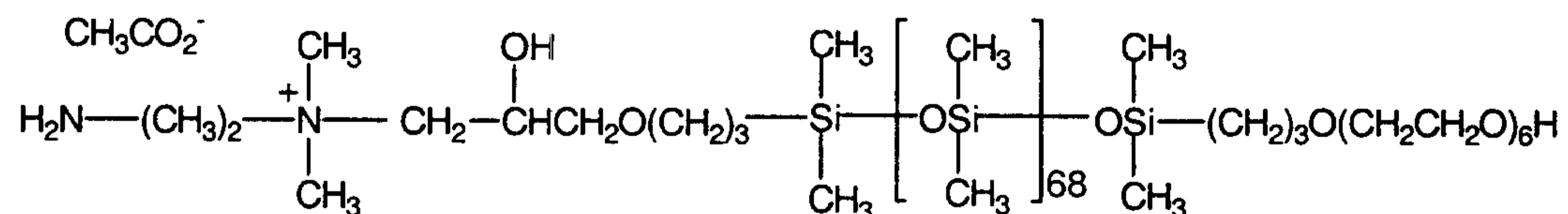

Example 3:

20 A 1 l three-necked flask equipped with a stirrer, intensive condenser, thermometer and dropping funnel was charged with 0.1 mol of 3-N,N-dimethylaminopropyl laurylamide and 45 ml of 2-propanol, and 0.1 mol of acetic acid was added at 20°C. The
25 mixture was allowed to react at 25°C for 30 minutes and

then 0.1 mol of the epoxy polyethersiloxane of the formula

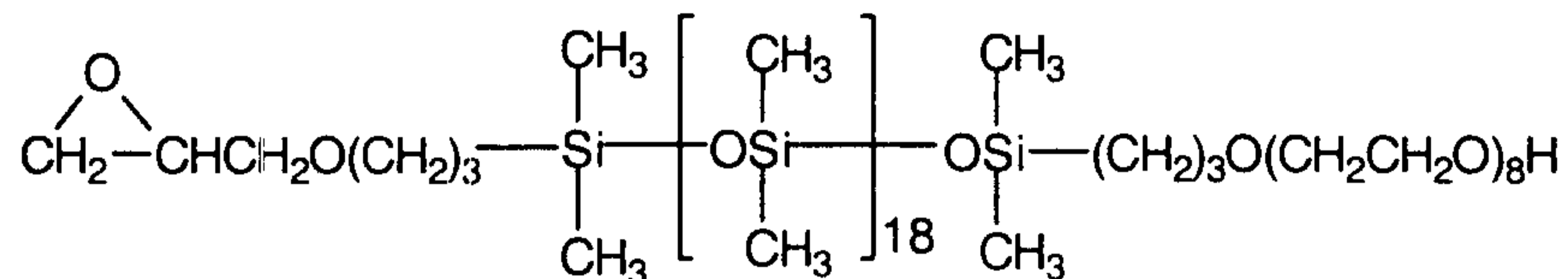

5

was added dropwise. The reaction was conducted and the product worked up as in Example 1. According to the results of ^{29}Si -NMR and ^{13}C -NMR spectroscopy, the end product has the following structure:

10

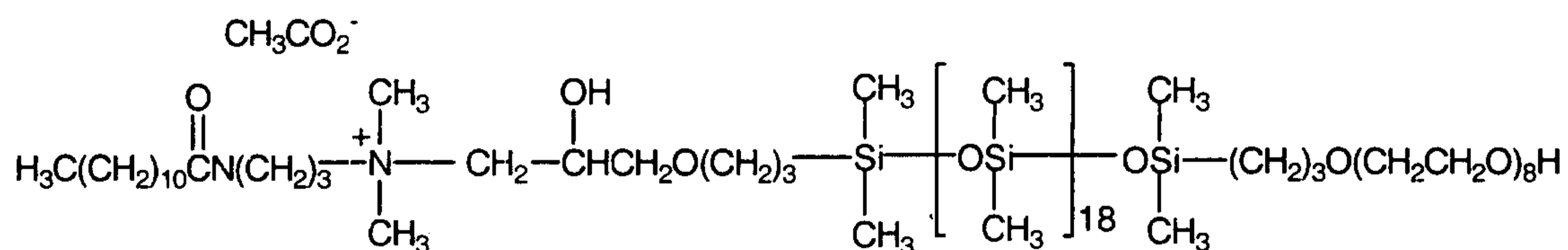

Example 4:

15 A 1 1 three-necked flask equipped with a stirrer, intensive condenser, thermometer and dropping funnel was charged with 0.1 mol of dimethylaminopropylamine and 45 ml of 2-propanol, and 0.1 mol of acetic acid was added at 20°C. The mixture was allowed to react at 25°C
20 for 30 minutes and then 0.1 mol of the epoxy polyethersiloxane of the formula

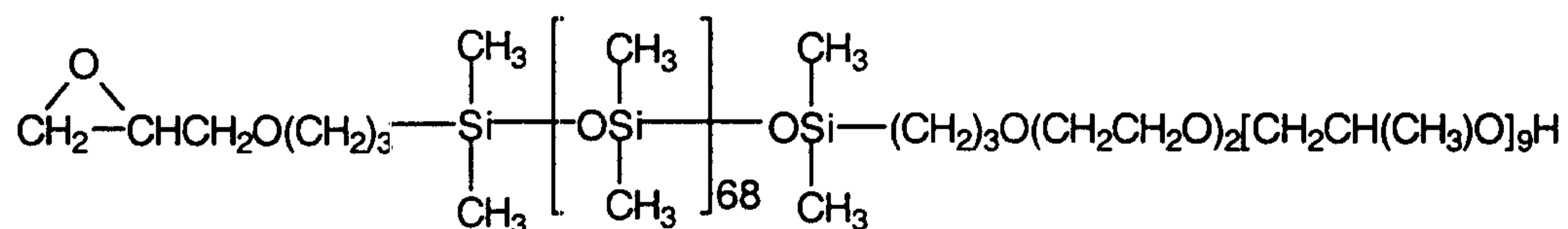

was added dropwise. The reaction was conducted and the product worked up as in Example 1.

- 5 According to the results of ^{29}Si -NMR and ^{13}C -NMR spectroscopy, the end product has the following structure:

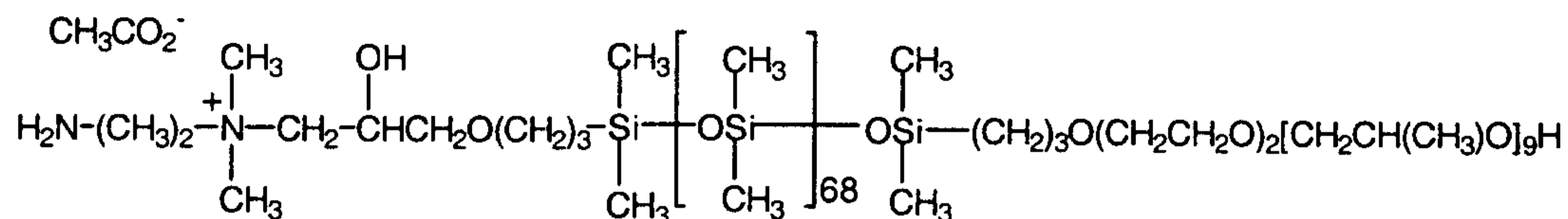

10

Example 5:

A 1 l three-necked flask equipped with a stirrer, intensive condenser, thermometer and dropping funnel
 15 was charged with 0.1 mol of tetramethyl-1,6-hexanediamine and 45 ml of 2-propanol, and 0.1 mol of acetic acid was added at 20°C. The mixture was allowed to react at 25°C for 30 minutes and then 0.1 mol of the epoxy polyethersiloxane of the formula

20

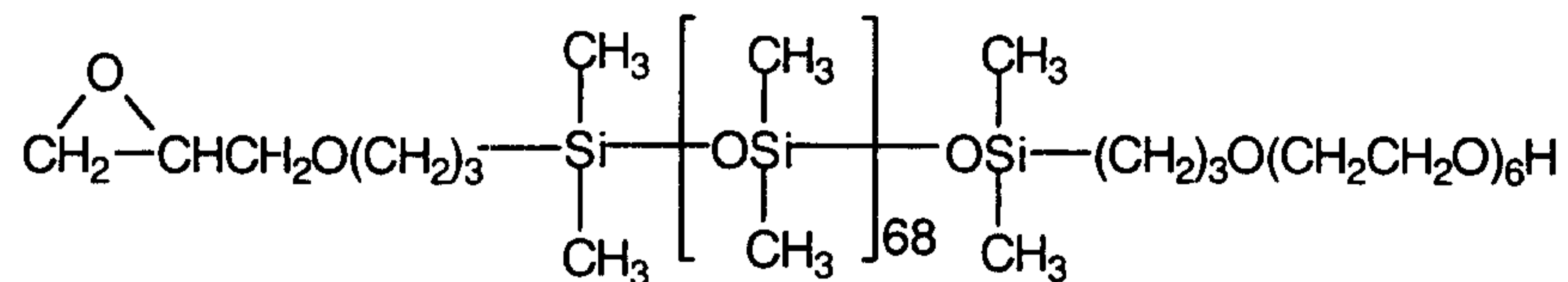

was added dropwise. The reaction was conducted and the product worked up as in Example 1. According to the

results of ^{29}Si -NMR and ^{13}C -NMR spectroscopy, the end product has the following structure:

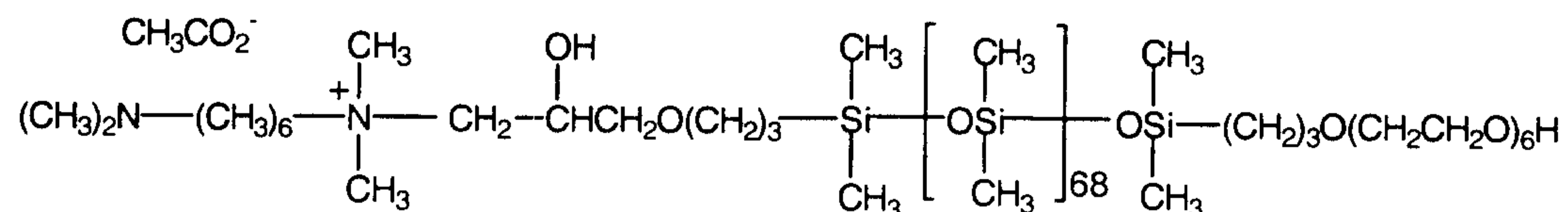

5

Example 6:

A 1 l three-necked flask equipped with a stirrer, intensive condenser, thermometer and dropping funnel was charged with 0.1 mol of poly(10)oxyethyleneoctadecylamine and 45 ml of 2-propanol, and 0.1 mol of acetic acid was added at 20°C. The mixture was allowed to react at 25°C for 30 minutes and then 0.1 mol of the epoxy polyethersiloxane of the formula

15

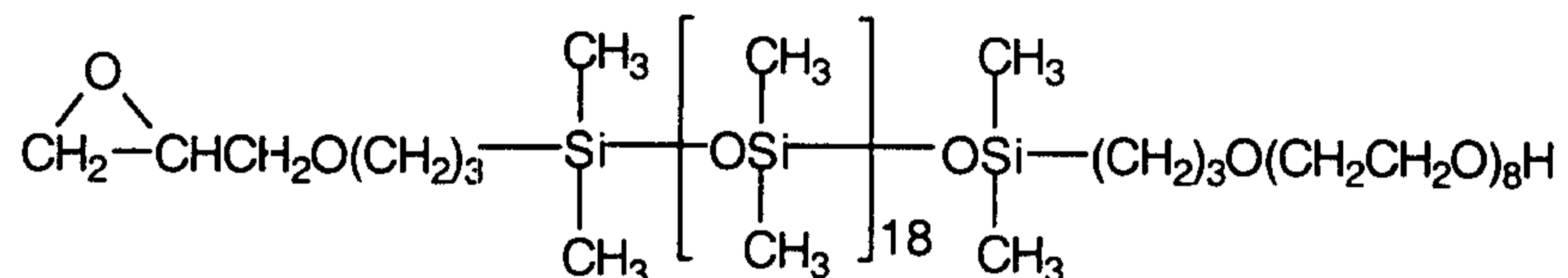

was added dropwise. The reaction was conducted and the product worked up as in Example 1. According to the results of ^{29}Si -NMR and ^{13}C -NMR spectroscopy, the end product has the following structure:

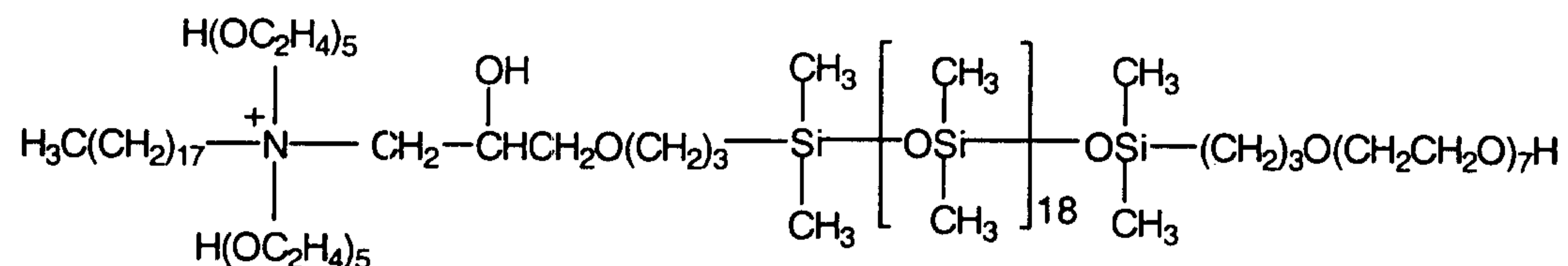

The compounds of the invention possess a good soft hand and low yellowing tendency and permit the permanent finishing of substrates (cotton, polyesters, fleeces, nonwovens, leather).

In order to test the hydrophilicity of the compounds of the invention and of a siloxane functionalized with ammonium groups and of a siloxane functionalized with polyalkoxy groups, one cotton fabric in each case was treated with a 1% strength by weight isopropanolic solution of the active substance and squeezed off on a pad mangle (load: 30 kg). This was followed by fixing at 150°C for 3 minutes. The result was a very soft, pleasant hand of the textile substrate finished with the compounds of the invention.

The hydrophilicity was tested using the TEGEWA drop test (Melliand Textilberichte 68 (1987) 581 ff. The finished fabric was clamped horizontally on a tensioner without coming into contact with the base. A water droplet of 0.050 ml \pm 10% was dropped onto the fabric from a height of 40 mm. As soon as the droplet hit the material under test, a measurement of the time was begun. The time measurement was stopped when the droplet had penetrated fully into the fabric and the gloss had disappeared or when the droplet took more than 300 seconds to penetrate the material under test.

In the latter case, the measurement was terminated and the value ">300 sec" was entered.

Product	Hydrophilicity values on cotton fabric after application [sec]
untreated	2
1	70
2	90
3	50
4	>300
5	140
6	50

What is claimed is:

1. A polysiloxane having polyether quat functions, of
5 the general formula I

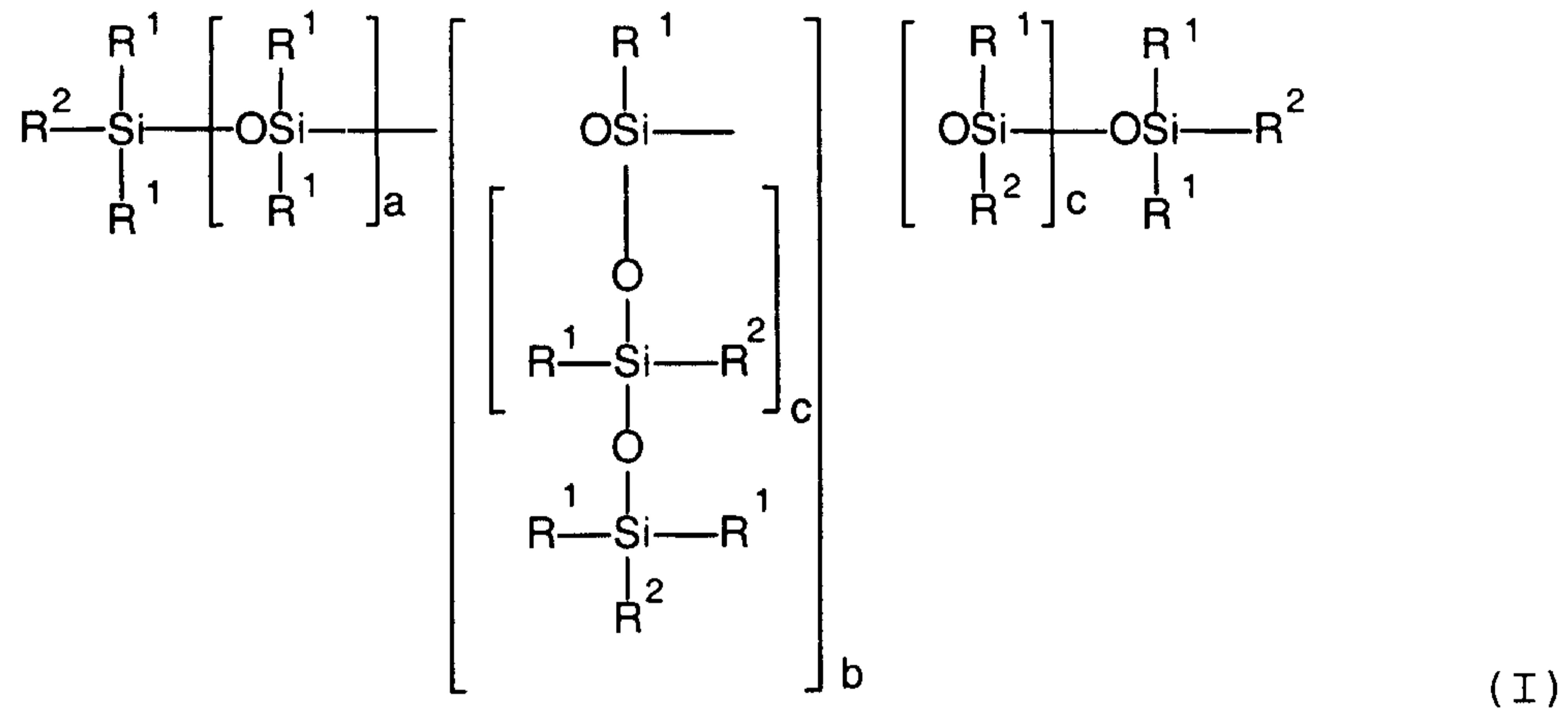

where

10 a = from 5 to 500,

b = from 0 to 50,

c = from 0 to 20,

R¹ = identical or different aliphatic or aromatic
carbon radicals of 1 to 8 carbon atoms,

15 R² = R^{2A} or R^{2B}, with the proviso that there is at
least one radical R^{2A} and R^{2B} on the siloxane
framework,

R^{2A} = a polyether radical of the formula II

20 - (Y) [O(C₂H_{4-d}R³_dO)_e(C_fH_{2f}O)_gX]_n (II)

where

Y = an (n + 1)-valent, optionally branched hydrocarbon radical,

d = from 1 to 3,

e = from 1 to 20,

5 f = from 2 to 4,

g = from 1 to 20,

X = hydrogen, or a monovalent hydrocarbon radical or an acyl radical each of 1 to 10 carbon atoms,

n = from 1 to 4,

10 the radicals R^2 being identical or different in each case,

R^{2B} = a group -M-Z

where Z is selected from the group consisting of

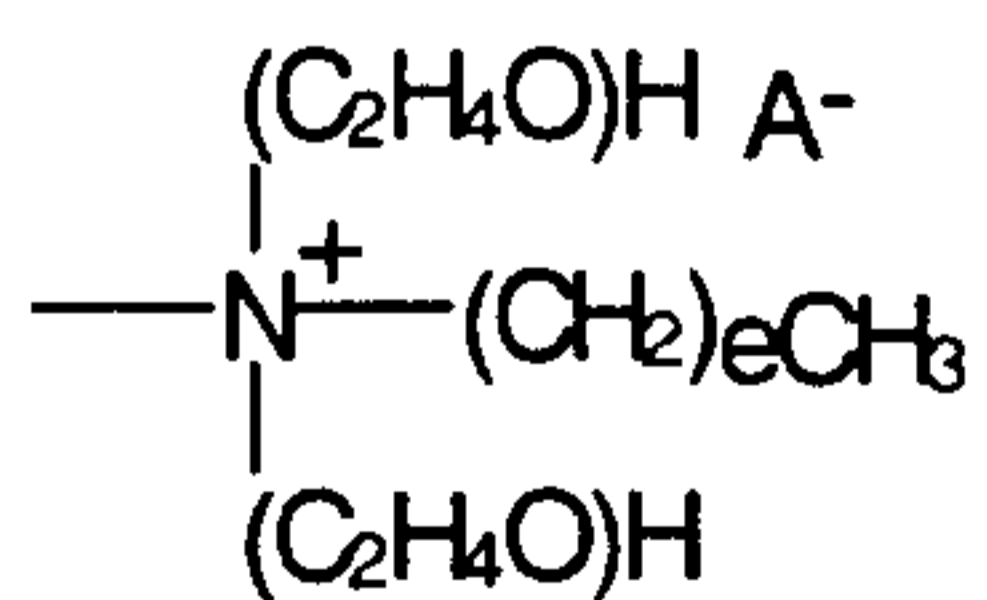

$R^3, R^4, R^5, R^6 =$ in each case independently of one another, hydrogen or alkyl of 1 to 22 carbon atoms,

$R^7 = -O-; -NR^9-$,

5 $R^8 =$ an $(n + 1)$ -valent, optionally branched hydrocarbon radical, and

$R^9 =$ hydrogen or alkyl of 1 to 6 carbon atoms,

10 $A =$ a counterion to the positive charges on the quaternized nitrogen groups, selected from organic or inorganic anions of physiologically compatible acids HA,

15 $M =$ a divalent radical selected from the group consisting of

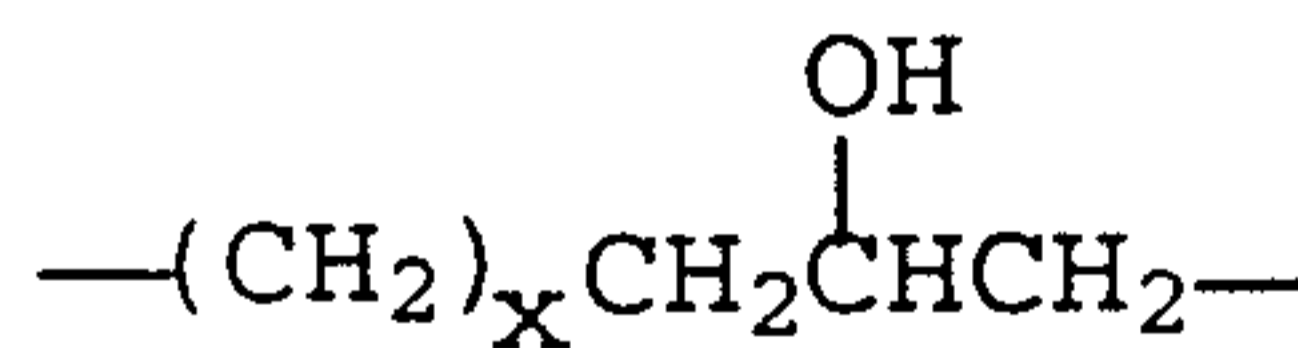
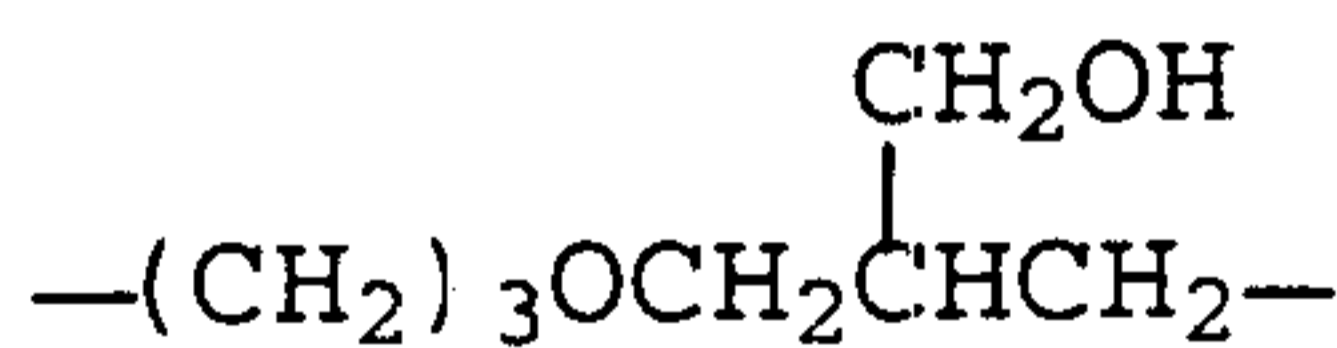
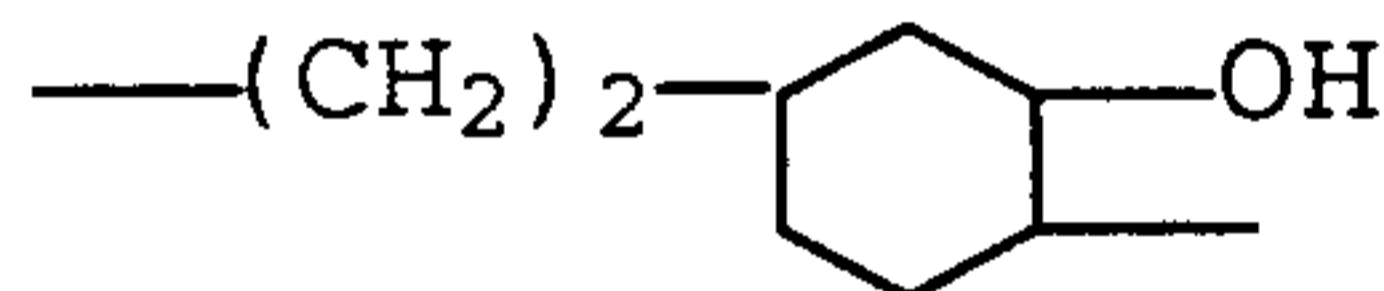
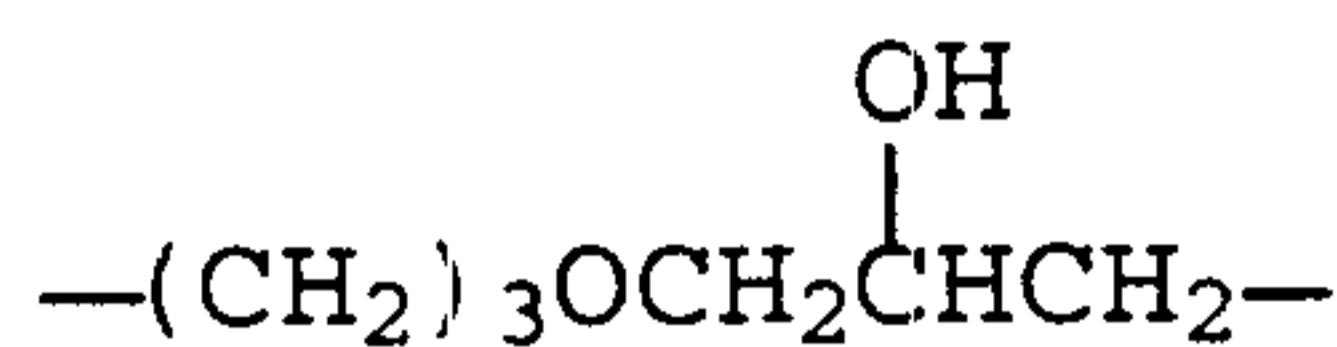

20

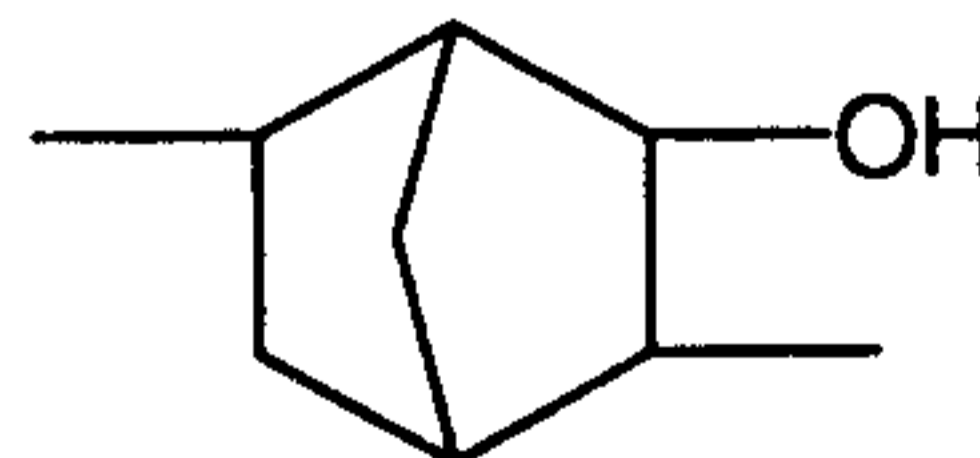
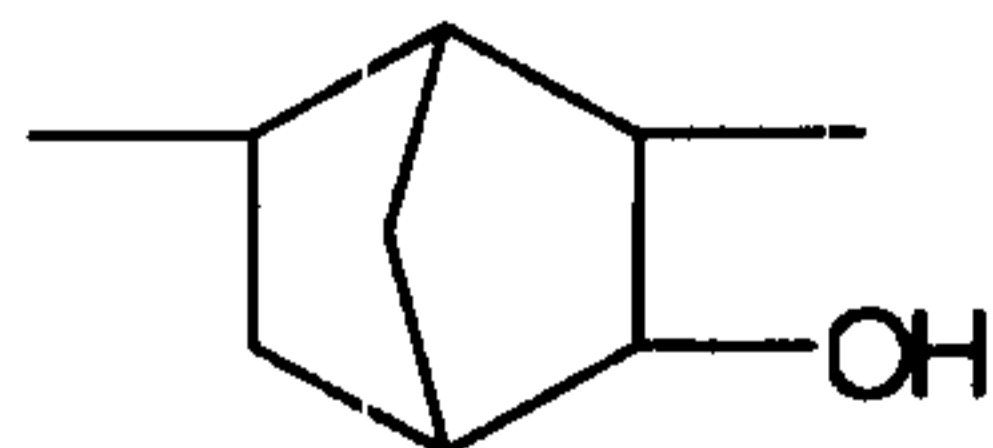
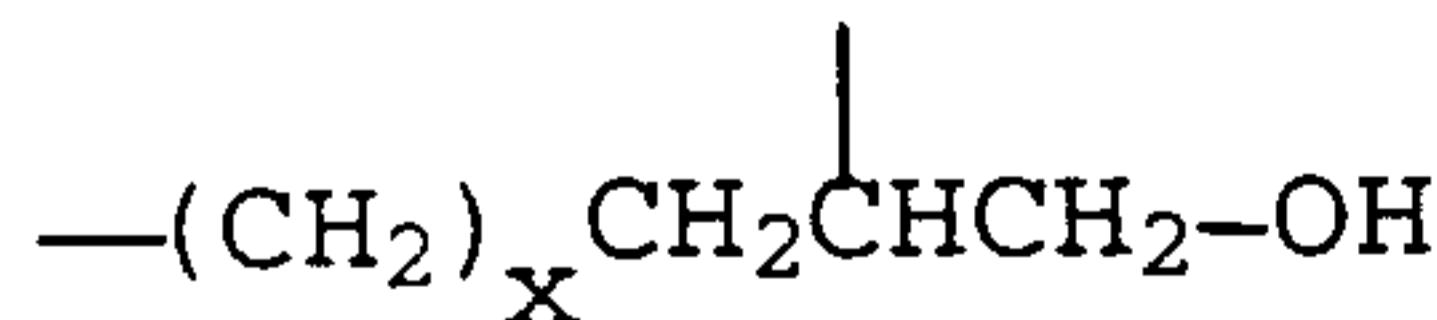
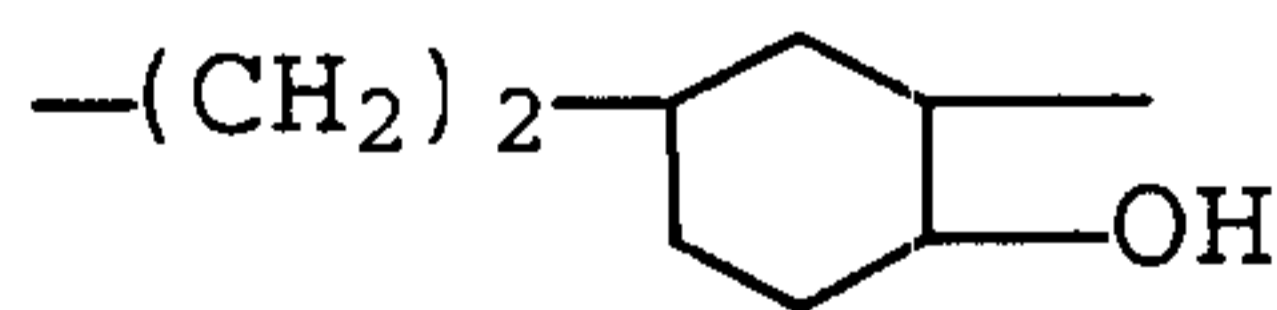

2. A polysiloxane as claimed in claim 1, wherein
a = from 5 to 300,
b = from 0 to 20,
c = from 0 to 5, and
5 a + b + c \geq 25.
3. A polysiloxane as claimed in claim 1, wherein the
polyether radical of general formula II represents
polyether radicals in blockwise mixture.
- 10
4. A polysiloxane as claimed in any one of claims 1
to 3, wherein the physiologically compatible acid
HA is selected from acetic acid, L-hydroxy-
carboxylic acids, and aromatic carboxylic acids.