



(11) **EP 2 182 129 B1**

(12) **EUROPEAN PATENT SPECIFICATION**

(45) Date of publication and mention of the grant of the patent:
14.12.2011 Bulletin 2011/50

(51) Int Cl.:
E04B 9/30 (2006.01) **E04B 9/12** (2006.01)
E04B 9/18 (2006.01)

(21) Application number: **09174640.4**

(22) Date of filing: **30.10.2009**

(54) **A suspendable ceiling island system**

Aufhängbares Deckeninselsystem

Système d'îlots de plafond suspendu

(84) Designated Contracting States:
AT BE BG CH CY CZ DE DK EE ES FI FR GB GR HR HU IE IS IT LI LT LU LV MC MK MT NL NO PL PT RO SE SI SK SM TR

(30) Priority: **30.10.2008 EP 08167915**

(43) Date of publication of application:
05.05.2010 Bulletin 2010/18

(73) Proprietor: **Chicago Metallic Continental 2110 Wijnegem (BE)**

(72) Inventors:
• **Stessel, Wilfried B - 2520, Ranst (BE)**

• **Borgers, Stéphane B - 2640, Mortsel (BE)**

(74) Representative: **Luys, Marie-José A.H. et al Gevers Intellectual Property House Holidaystraat 5 1831 Diegem (BE)**

(56) References cited:
EP-A- 0 516 330 EP-A- 1 811 098
US-A- 5 937 605 US-B1- 6 298 623

EP 2 182 129 B1

Note: Within nine months of the publication of the mention of the grant of the European patent in the European Patent Bulletin, any person may give notice to the European Patent Office of opposition to that patent, in accordance with the Implementing Regulations. Notice of opposition shall not be deemed to have been filed until the opposition fee has been paid. (Art. 99(1) European Patent Convention).

Description

[0001] The present invention relates to a suspendable ceiling island system comprising at least one frame member for forming a frame at least partly delimiting a ceiling island comprising at least one ceiling tile, the frame member comprising a longitudinally extending upright web with a first and second longitudinally extending profile flange mounted along opposite respective first and second longitudinal sides of the upright web and pointing away from the upright web from the respective first and second longitudinal side along an extending direction, a clamping element comprising clamping means for mounting the clamping element to the frame member by clamping the clamping element in a clamping volume delimited by the first and the second profile flanges and the upright web such that an assembly of the frame member and the clamping element is formed, the clamping element when mounted to the frame member being substantially located in the clamping volume, according to the preamble of the first claim.

[0002] EP0516330A2 describes a suspendable ceiling island system, according to the preamble of claim 1, comprising a frame with a plurality of longitudinal and transverse runners which form a suspension grid to support the edges of the ceiling tiles forming the island. The ceiling island is suspended to the existing building construction, by suspending the runners using conventional hangers. The end parts of the longitudinal and transverse runners are received in the inner volume of frame members, which run along the edges of the ceiling island to provide a finishing of the longitudinal and transverse edges of the ceiling island. Each frame member comprises a longitudinally extending upright web and a first and a second profile flange, which extend in longitudinal direction of the upright web and point perpendicularly away from opposite sides of the upright web. The edges of the first and second profile flanges are provided with respectively a first and second hemmed edge. The frame members are attached to the end parts of the runners, using a clamping element which substantially fits into the inner volume of the frame member delimited by the upright web and the first and second profile flanges. To achieve this, the clamping element comprises an upright side provided to run along the upright web of the frame member, a bottom flange provided to be clamped between the upright web and the second hemmed edge and a top flange provided with an upwards extending lip provided to clamp the top flange between the first hemmed edge and the upright web of the frame member. The top flange of the clamping element extends from the inner volume of the frame member, over at least part of the bead of the runner and is fastened to it.

[0003] The ceiling island system described by EP0516330A2 necessarily includes runners, as they provide the support for the ceiling tiles, also for those tiles which run along the frame members. The runners are also indispensable for the suspension of the ceiling is-

land. Runners therefore form an indispensable part of the ceiling island of EP0516330A2. Thereby, the physical properties and position in the ceiling island needs to be adapted to permit suspension of the ceiling island in each particular situation. It is however not always desired to include runners when designing a ceiling island, nor is it always desirable to adapt the physical properties and/or position of the runners to the suspension of the ceiling island.

[0004] Accordingly it is an aim of the current invention to provide a ceiling island system which does not necessarily involve the use of runners.

[0005] This is achieved according to the present invention with a ceiling island system according to claim 1.

[0006] The suspendable ceiling island system comprises suspending means for suspending the frame, the suspending means extend from the clamping volume and the assembly of the frame member and the clamping element is provided to receive and support at least part of the ceiling tile.

[0007] Because the suspending means extend from the clamping volume, sufficient room is left in the clamping volume for receiving at least part of a ceiling tile along at least part of at least one of its edges. Thereby the flanges of the frame member function as a support for at least a part of at least one edge of the ceiling tile. Part of the edge of the ceiling tile is received within the clamping element. As a result, part of the ceiling tile is directly supported by a flange of the frame member and part of the ceiling tile is supported by the assembly of the frame member and the clamping element. This support is achieved without having to install a runner to at least partly support the ceiling tile. Because the suspending means extend from the clamping member, the framed ceiling island can be suspended directly at the frame members without having to use runners to effectuate the suspension. The fact that the use of runners is no longer critical to permit suspension of the ceiling island and receiving and supporting the ceiling tiles at the frame members presents a significant advantage of the ceiling island system of this invention.

[0008] Since the presence of runners in the vicinity of the frame members is no longer necessary for providing a support surface for the edges of the ceiling tiles positioned in the vicinity of the frame members, the number of runners used in the ceiling island can be substantially reduced. This way the weight of the ceiling island as well as the material cost may be substantially reduced.

[0009] The inventor has moreover found that the presence of the clamping element in the internal volume of the frame member provides a local reinforcement of the frame member. This way the strength of the frame members, their resistance to bending as well as the rigidity of the whole frame is improved. Strengthening the frame members is especially desired when frame members of considerable length are used and there is a risk of deflection due to its own weight.

[0010] The inventor has also observed that since the

clamping element is capable of receiving and supporting a ceiling tile along at least part of its edge and is provided with suspending means, the weight of the ceiling tile received by the clamping element is more directly carried by the clamping element. As a consequence, the frame member no longer needs to be provided to carry the total weight of the ceiling tile so that the load bearing capacity of the frame member can be decreased, leading, for example, to less stringent material properties of the frame member. As a consequence the frame member can be more specifically adapted to align different clamping elements and/or the decorate the frame, etc.

[0011] According to the current invention the suspending means extend from a part of the clamping element running along the first profile flange when the clamping element is mounted to the frame member.

[0012] The inventor has found that such suspending means leave more distance between the suspending means and the ceiling tile, when provided in the frame. By providing such additional distance between the suspending means and the ceiling tile, the inventor has found that connecting the suspending means to means connecting the suspending means to for example a ceiling, such as for example a cord, can be performed more easily.

[0013] According to the invention, the suspending means extend in an upward direction, as defined in the characterising part of claim 1.

[0014] The inventor has found that such suspending means provide even more distance between the suspending means and the ceiling tile, when provided in the frame. Such suspending means therefore allow that the connecting means can be even more easily connected to the means connecting the suspending means to for example a ceiling.

[0015] Other details and advantages of the device according to the invention will become apparent from the enclosed figures and description of preferred embodiments of the invention.

Figure 1 a shows a view in perspective of a clamping element of the suspended ceiling island system according to the invention.

Figure 1b shows a sectional view of the clamping element of figure 1 a.

Figure 1c shows a frontal view of the clamping element of figure 1 a.

Figure 1d shows a top view of the clamping element of figure 1 a.

Figure 2a shows a view in perspective of a ceiling island system according to the invention.

Figure 2b shows another embodiment of the ceiling island system of figure 2a.

Figure 3a shows a detail of figure 2a.

Figure 3b shows a detail of figure 2b.

Figure 4 shows a detail of a different embodiment of the ceiling island system according to the invention.

Figure 5 shows a detail of another embodiment of

the ceiling island system according to the invention. Figure 6 shows a detail of another embodiment of the ceiling island system according to the invention. Figure 7 shows a frame of a ceiling island system according to the invention.

Figure 8 shows another frame of a ceiling island system according to the invention.

Figure 9a shows a side view an embodiment of a part of the assembly of the ceiling island system according to the invention.

Figure 9b shows a top overview of an embodiment of a part of a ceiling island system according to the invention.

Figure 2a shows a ceiling island system 1 according to the invention. The ceiling island system 1 comprises at least one frame member 10 for forming a frame 9. The frame 9 at least partly delimits a ceiling island having at least one tile 16.

[0016] The ceiling island shown in figure 2a is provided to be hung to a ceiling so that at least part of the ceiling is covered. This is however not critical for the invention and the ceiling island system 1 can also be provide to be mounted to a wall such that at least part of the wall is covered by the ceiling island.

[0017] Preferably, the frame 9 fully encloses the at least one tile 16 forming a circumferential frame 9, as shown in figure 2a and 2b. However, configurations in which the frame 9 does not fully enclose the tiles 16 are also possible, in which case, for example, the sides of the suspendable ceiling island system 1 not enclosed by the frame 9 can be positioned adjacent to one or more sides of a wall. The dimensions of the ceiling island substantially depend on the dimensions of the frame 9. As a consequence its dimensions can be chosen independently from the dimensions of the ceiling, or wall as described above, to which the island ceiling system is suspendable and can be determined according to the desired physical properties of the ceiling island and the space covered by it related to for example specific heat insulating properties, sound proofing properties, preferred dimensions, etc. The ceiling island can therefore be mounted on specific locations where certain specific physical properties are requested. By suspending one or more distinct ceiling islands at specific locations in one room, the desired over-all physical properties for the room can be obtained, independently or in addition to any possible existing ceiling islands.

[0018] The circumferential frame 9 can for example be rectangular, square or triangular or can have any other form and shape depending upon the desired physical properties or depending upon esthetical considerations.

[0019] The frame members 10 can have any form deemed appropriate by the person skilled in the art, but preferably they are straight. Preferred frame members 10 for constructing the circumferential frame 9 are profiles comprising a first longitudinally extending upright web 6 with a first profile flange 7, i.e. an upper profile

flange 7, which extends in longitudinal direction of the first upright web 6 and which points away from the first upright web 6 from a first longitudinal side 17 in an extending direction. Preferably, the first longitudinal side 17 extends along an upper edge of the first upright web 6. The preferred frame member 10 also comprises a second profile flange 8, i.e. a lower profile flange 8, which points away from a second longitudinal side 18 of the frame member 10 in the extending direction and preferably extends along a bottom side of the first upright web 6 opposite to the first longitudinal side 17. The first 7 and the second 8 profile flanges preferably run mainly parallel to each other so that the frame member 10 is mainly C-shaped and oblong with a longitudinal opening facing the tiles 16 and/or interior of the circumferential frame 10. The first 7 and/or second 8 profile flanges preferably extend along the entire length of the frame member 10 but can also extend along part of the frame member 10. The first profile flange 7 and the second profile flange 8 preferably extend perpendicular to the first upright web 6.

[0020] The circumferential frame 9 may be composed of standard frame members 10 having a height of 40 mm between the first 7 and the second 8 profile flanges and the profile flanges having a width of 24 mm, written as 38 x 24 mm, but other sizes of for example 38 x 15 mm or others may suitably be used as well. The material thickness will usually be adapted taking into account the envisaged circumstances of use such as the dimensions of the frame 9 and the dimensions and weight of the ceiling tiles 16. Frame members 10 may have the same length as the length of the sides of the island ceiling system 1 or may be shorter or longer.

[0021] The frame members 10 may be linked to each other in longitudinal direction of the frame members 10 or in a direction which is angled, with respect to the longitudinal direction of the frame members 10. Frame members 10 may at a corner, for example, run substantially perpendicular or any other angle depending on the shape of the frame 10. The frame members 10 may also all lie in one mutual plane. This is however not critical for the invention.

[0022] Adjacent frame members 10 preferably are linked to each other to obtain the circumferential frame 9 using interconnecting pieces 30. The interconnecting pieces 30 preferably are also mainly C-shaped, but however also may be solid. Coupling in longitudinal and cross direction is achieved by using interconnecting pieces 30 which preferably have at least two end parts 28, 29, wherein a first end part 28 is positioned between an end part of the first 7 and second 8 profile flange of a first frame member 10 and a second end part 29 is positioned between an end part of the first 7 and second 8 profile flanges of a second frame member 10. The dimensions of the first 28 and second 29 end part of the interconnecting piece 30 preferably are such that the first 7 and second 8 profile flanges of the first and second adjacent frame members 10 exert a clamping action onto respectively the first 28 and second 29 end part of the intercon-

necting piece 30 in height direction thereof, thus fastening the first end part 28 of the interconnecting piece 30 to the first frame member 10 and the second end part 29 of the interconnecting piece 30 to the second frame member 10, therefore joining the two adjacent frame members 10 to each other. Alternatively, the height of the first 28 and/or second 29 end part of the interconnecting piece 30 can also be chosen so that the first 7 and second 8 profile flanges of the respective first and/or second frame member 10 are received in the respective first 28 and/or second 29 end part of the interconnecting piece 30 which exerts a clamping force onto the first 7 and second 8 profile flange of the respective first and/or second frame member 10.

[0023] In the interconnection piece 30 which interconnects two frame members 10 in longitudinal direction, the first 28 and second 29 end part are positioned in line with each other. In the interconnecting piece 30 which interconnects two frame members 10 in angled, for example perpendicular, position, the first 28 and second 29 end part of the interconnecting piece 30 are positioned angled, e.g. perpendicular, with respect to each other.

[0024] The interconnecting piece 30 and the frame member 10 preferably respectively comprise mutually co-operating interconnecting members which engage each other in a removable way, for example co-operating perforations and protrusions. The protrusions preferably are created by locally increasing the height of the material. The protrusions and/or perforations can have any form or shape deemed appropriate by the person skilled in the art such as rectangular, square, circular, oval, etc. When the interconnecting piece 30 and the frame member 10 engage one another, the protrusions snap into their corresponding perforations, preventing a relative movement in length direction of the frame members 10 of the interconnecting piece 30 and creating a reliable connection between two adjacent frame members 10 and their intermediate interconnecting piece 30. Although the thus created connection is reliable and strong, the protrusions can be pushed out off the perforations and thus the interconnecting pieces 30 and frame members 10 can be separated and joined without using any tools. Because of the C-shape, the interconnecting piece 30 preferably can be compressed somewhat in height direction therefore making it easier to push the protrusions out of the perforations when separating the interconnecting piece 30 from the frame members 10. However, alternatively or in combination the frame member 10 can be compressed somewhat in height direction therefore making it easy to pull the perforations over the protrusions when separating the interconnecting piece 30 from the frame members 10.

[0025] The frame members 10 can be made of any material deemed appropriate by the person skilled in the art such as for example plastic but preferably are made of metal. The interconnecting piece 30 preferably is made of plastic but any other material deemed appropriate by the person skilled in the art can be used, such as for

example metal, wood, etc.

[0026] The ceiling island system 1 according to the invention also comprises a clamping element 2 comprising clamping means 3 for mounting the clamping element 2 to the frame member 10 by clamping the clamping element 2 between the first 7 and the second 8 profile flanges such that an assembly of the frame member 10 and the clamping element 2 is formed. The clamping element 2 when mounted to the frame member 10 is substantially located in a clamping volume 26 delimited by the upright web 6 and the first 7 and the second 8 profile flanges, as shown in figures 2a - 8.

[0027] The clamping element 2 comprises suspending means 5 for suspending the frame 9. The suspending means 5 extend out of the clamping volume 26 when the clamping element 2 is mounted to the frame member 10 although a substantial part of the clamping element 2, with respect to the suspending means 5, is located in the clamping volume 26. The assembly of the frame member 10 and the clamping element 2 is provided to receive and support at least part of the ceiling tile 16.

[0028] The clamping means 3 preferably comprise at least one clamping element flange 11, i.e. a first upper clamping element flange 11, preferably at least two clamping element flanges 11, 12, provided to clamp the clamping element 2 in between the first 7 and second 8 profile flange. Although one clamping element flange 11, preferably at least two clamping element flanges 11, 12, are sufficient to clamp the clamping element 2 in between the first 7 and the second 8 profile flange, the clamping means shown in figures 1 - 8 comprise three clamping element flanges 11, 12, 13: a first clamping element flange 11, a second clamping element flange 12, i.e. a second lower clamping element flange 12, and a third clamping element flange 13. The clamping element 2 can however also comprise more than three clamping element flanges 11, 12, 13 provided to clamp the clamping element 3 in between the first 7 and second 8 profile flange, for example: four, five six, seven eight, nine ten, eleven, etc....

[0029] The clamping element flanges 11, 12, 13 can be made of any material deemed appropriate by the person skilled in the art. Preferably, the material of the clamping element flanges 11, 12, 13 is metal, more preferable steel more preferable stainless steel. However, any other material can be used for the clamping element flanges 11, 12, 13 such as for example aluminium, for example extruded aluminium, plastic, etc.

[0030] The different clamping element flanges 11, 12, 13 of the clamping means 3 can be interconnected in any way known to the person skilled in the art such as gluing, soldering, welding, bolting, stapling, riveting, nailing, etc. The different clamping element flanges 11, 12, 13 however are preferably interconnected by folding lines. Although a different interconnection can be used between each pair of clamping element flanges 11, 12, 13, the different clamping element flanges 11, 12, 13 preferably are all interconnected by folding such that the different

clamping element flanges 11, 12, 13 of the clamping means 3 can be folded from a single piece of material, preferably a piece of metal. Such clamping means 3 are for example shown in figure 1a - 1d.

[0031] The third clamping element flange 13 preferably is provided to be positioned in the clamping volume 26 in an upright direction extending from the second profile flange 8 towards the first profile flange 7. The first clamping element flange 11 preferably extends from a first side 21 of the third flange 13 and is provided to extend towards the first profile flange 7 when the clamping element 2 is mounted to the frame member 10. The second clamping element flange 12 preferably extends from a second side 22 of the third flange 13 opposing the first side 21 of the third flange 13 and is provided to extend towards the second profile flange 8 when the clamping element 2 is mounted to the frame member 10. The first 11, second 12 and third 13 clamping element flanges are provided to clamp the clamping element 2 between the first 7 and the second 8 profile flanges such that an assembly of the frame member 10 and the clamping element 2 is formed.

[0032] Although figures 2 - 8 show that the first 11 and the second 12 clamping element flange run substantially along the first 7 and the second 8 profile flange along the extending direction when clamping the clamping element 2 between the first 7 and/or second 8 profile flange, the direction in which the first 11 and/or the second 12 clamping element flange is not critical for the invention and the first 11 and/or the second 12 clamping element flange may also extend along a different direction. The first 11 and second 12 clamping element flange can for example extend along a direction substantially opposing the extending direction, perpendicular to the extending direction, along an angle of substantially between 30 - 60° with the extending direction, for example substantially 45°.

[0033] Although figures 2 - 8 show that the first 11 and/or second 12 clamping element flange are provided to run substantially along the first 7 and/or second 8 profile flange when clamping the clamping element 2 between the first 7 and second 8 profile flange, this is not critical for the invention and the flange may also not run substantially along any one of the profile flanges 7, 8.

[0034] Although figures 2 - 8 show that the first 11 and/or the second 12 clamping element flange are provided to run substantially along the entire length of the first 7 and/or second 8 profile when clamping the clamping element 2 between the first 7 and second 8 profile flange, this is not critical for the invention and the flange may also run partially along any one of the profile flanges 7,8.

[0035] Although figures 2 - 8 show that the third clamping element flange 13 is provided to run substantially along the upright web 6 when clamping the clamping element 2 between the first 7 and second 8 profile flange, this is not critical for the invention and the third clamping element flange 13 can also be provided not to run substantially along the upright web 6. The third clamping

element flange 13 can for example be provided not to run parallel to the upright web 6 and/or from a distance from the upright web 6.

[0036] Although figures 2 - 8 show that the third clamping element flange 13 is provided to run substantially along the entire length of the upright web 6 when clamping the clamping element 2 between the first 7 and second 8 profile flange, this is not critical for the invention and the flange may also run partially along the upright web 6.

[0037] The inventor has found that when the first 11, the second 12 and/or the third 13 clamping element flange runs substantially along the respective first profile flange 7, second profile flange 8 and/or upright web 6 more room is provided to receive and support at least part of the ceiling tile 16. The inventor moreover found that when the first 11, the second 12 and/or the third 13 clamping element flange runs substantially along the respective first profile flange 7, second profile flange 8 and/or upright web 6 the strength of the frame member 10 is further improved. More preferably, the first 11, the second 12 and the third 13 clamping element flanges are provided to run substantially along the respective first profile flange 7, second profile flange 8 and upright web 6, since in such a case the clamping volume 26 can be almost entirely used for receiving and supporting the ceiling tile 16 such that an improved support of the ceiling tile 16 is achieved. The inventor moreover found that in such case the frame member 10 is even further reinforced.

[0038] The suspending means 5 can be any means known to the person skilled in the art for suspending a ceiling island. The clamping element 2 can for example be provided with suspending means 5 provided for receiving a cord such as an opening, hook, etc.

[0039] Preferably, the suspending means 5 extend from a part of the clamping element 2 lying substantially along the first 7 or second 8 profile flange when the clamping element 2 is mounted to the frame member 10. More preferably, the suspending means 5 extend, more preferably extend substantially, in an upward direction. The inventor has found that when the suspending means 5 leave some distance between the suspending means 5 and the ceiling tile 16, when provided in the frame 9, as for example shown in figure 3a, connecting the suspending means 5 to the means connecting the suspending means to for example a ceiling, such as for example a cord, can be performed more easily.

[0040] The inventor has moreover found that the distance between the suspending means 5 and the ceiling tile 16, when provided in the frame 9, also allows that when tiles 16 having a thickness extending along substantially the upright length of the upright web 6 of the frame member 10 are provided to the frame member 10, the suspending means 5 can still be used to suspend the frame 9, since the distance between the suspending means 5 and the ceiling tile 16 allows that the means for connecting the suspending means 5 to the ceiling can

be attached to the suspending means 5. For example, the distance between the suspending means 5 and the ceiling tile 16 allows that for example a cord is knotted to the suspending means 5.

[0041] The suspending means 5 preferably extend in an upright direction from the end of the first clamping element flange 11, which end is situated opposite to the end of the first clamping element flange 11 that is connected to the third clamping element flange 13, such that the suspending means 5 protrudes above the plane defined by the first 7 profile flange.

[0042] Figures 1 - 8 show that the suspending means 5 comprise a fourth clamping element flange 14. The clamping element flange 14 shown in figures 1 - 8 extends from the clamping means 3, more specifically from the first flange 11. Preferably, the suspending means 5 comprise a fourth clamping element flange 14 which extends, preferably directly, from the end of the first clamping element flange 11, which end is situated opposite to the end of the first clamping element flange 11 that is connected to the third clamping element flange 13. The fourth clamping element flange 14 then protrudes above the plane defined by the first 7 profile flange.

[0043] The fourth clamping element flange 14 preferably is similar to the first 11, second 12 and third 13 clamping element flanges and therefore preferably is made from metal, more preferably steel, even more preferably stainless steel. More preferably, similar to the first 11, second 12 and third 13 clamping element flanges, the fourth clamping element flange 14 is connected to the first clamping element flange 11 by a folding line.

[0044] As shown in figures 1 - 8 and as discussed above, the fourth clamping element flange 14 preferably extends in an upright direction from the clamping means 3. This is however not critical for the invention and the fourth clamping element flange 14 can also extend in a downward direction or for example a direction running substantially along the extending direction.

[0045] The fourth clamping element flange 14 can be provided with an opening provided for receiving an end part of the means connecting the suspending means 5 to the ceiling. The opening can for example be provided to receive an end part of a cord which can be knotted to the hole, a hook attached to the end part of a cord as shown in figure 2b and 3b or can be provided to be screwed to a piece provided thereto to an end part of the cord such as shown in figure 2a and 3a.

[0046] Preferably, as shown in figures 1 - 8, the suspending means 5 comprise a fifth clamping element flange 15 extending preferably from the fourth clamping element flange 14 in a direction substantially along the extending direction when the clamping element 2 is mounted to the frame member 10.

[0047] The fifth clamping element flange 15 preferably is similar to the first 11, second 12, third 13 and fourth 14 clamping element flanges and therefore preferably is made from metal, more preferably steel, even more preferably stainless steel. More preferably, similar to the first

11, second 12, third 13 and fourth 14 clamping element flanges, the fifth clamping element flange 15 is connected to the fourth clamping element flange 14 by a folding line.

[0048] Although the figures 1 - 8 show that the fifth clamping element flange 15 extends in a direction substantially along the extending direction, the fifth clamping element flange 15 can also extend in a downward direction or for example an upward direction.

[0049] The fifth clamping element flange 15, as shown in figures 1 - 8, preferably is provided with an opening provided for receiving an end part of the means connecting the suspending means 5 to the ceiling. The opening can for example be provided to receive an end part of a cord which can be knotted to the hole, a hook attached to the end part of a cord as shown in figure 2b and 3b or can be provided to be screwed to a piece provided thereto to an end part of the cord such as shown in figure 2a and 3a.

[0050] Although the ceiling island can be suspended to the ceiling using cords, as shown in figures 2a, 2b, 3a and 3b, other means can also be used to suspend the ceiling island to the ceiling such as for example bars, rods, etc.

[0051] A first example is shown in figure 4 in which the suspending means 5 are provided to be clamped to the ceiling or wall of a room. In the specific embodiment shown at least part of the suspending means 5, more specific the fifth flange 15, are clamped to the wall by pressing a mounting piece 31 onto the at least part of the suspending means 5, more specific the fifth flange 15.

[0052] The mounting piece 31 can however also be omitted, as shown in figure 5, and the suspending means can be directly screwed, nailed, stapled, etc. to the wall or ceiling, as shown in figure 5. The suspending means 5 however do not need to be connected directly to the wall or ceiling as shown in figure 5, but can also be mounted to an intermediate piece 32, as shown in figure 6.

[0053] The intermediate piece 32 shown in figure 6 is provided to be mounted to the wall or ceiling and comprises an opening provided to bolt, nail, staple, etc. the suspending means 5 to it. The opening, as shown in figure 6, preferably is longitudinal such that the mounting location of the suspending means to the intermediate piece 32 can be adapted more easily while installing the ceiling island.

[0054] Figures 7 and 8 show that the intermediate piece 32 allows a multitude of mounting arrangements of the ceiling island. Figure 7 for example show the application of the clamping element 2 in combination with the intermediate piece 32 to mount frames 10 to a wall having a curved surface. Figure 8 for example shows the application of the clamping element 2 in combination with the intermediate piece 32 to mount the frames 10 to an angled wall surface.

[0055] Figure 9a and figure 9b show a different way to use the assembly of the frame member 10 and the clamping element 2. Here, the clamping element 2, more specifically the suspending means 5, is connected to a T-

shaped runner 33 as shown in figure 9b. Such a construction can be used to mount tiles 16 in the plane defined by the frame members 10 where the runner 33 is used to support the tiles 16 without the runner 33 being visible from below, known in the sector as an invisible mount. Thereto, the tile 16 comprises a groove in which a supporting flange 34 of the runner 33 can be received, the depth of the flange preferably being substantially the width of the runner 33 so that two tiles 16 cover substantially the underside of the runner 33. In such a mounting, the thickness of the tiles 16 below the groove when mounted to the runner 33 added to the height of the runner 33 substantially equals the sum of the height of the frame member 10 and the height along which the suspending means 5 extend to the mounting location of the top of the runner 33 with the suspending means 5, which often is the height of the fourth flange 14 measured along its upright direction. In such a configuration when the tile 16 is slid with its groove over the flange 34 of the runner 33, part of the tile 16 can extend in the clamping volume 26. Such a system provides a system in which tiles 16 can be mounted in an invisible mount using known runners 33. Moreover, in such a system the runners 33 add to the strength of the system as they improve the fixation of the frame members 10 with respect to the remainder of the ceiling island system in which they are mounted.

[0056] Often the height of the frame member 10 and the height of the runner 33 are substantially the same such that the height along which the suspending means 5 extend to the mounting location of the top of the runner 33 with the suspending means 5, which often is the height of the fourth flange 14 measured along its upright direction, is the same as the thickness of the tile 16 below the groove when mounted to the runner 33. Such a system allows to use frame members 10 and runners 33 to mount tiles 16 in a visible mount, in which the underside of the runners 33 is visible from below, as for example described in EP 1 811 098 A1, and an invisible mount as discussed above using the same runners 33 and frame members 10. Therefore, the clamping element 2 adds to the possibilities to use runners 33 and frame members 10.

[0057] Preferably the assembly of the frame member 10 and the clamping element 2 comprises positioning means 4 for positioning the clamping element 2 in the clamping volume between the first 7 and the second 8 profile flange along the extending direction when mounted to the frame member 10.

[0058] The positioning means 4 shown in figure 3a and 3b comprise a second hemmed edge 20 provided on the second profile flange 8 of the frame member 10. The second hemmed edge 20 comprises a part of the second profile flange 8 which is folded to extend along the second profile flange 8 onto a second inner face 25 of the second profile flange 8 facing the clamping volume 26. The second hemmed edge 20 is provided to cooperate with the clamping means 3 to position the clamping element 2 in the clamping volume 26 between the first 7 and the sec-

ond 8 profile flange along the extending direction when mounted to the frame member 10.

[0059] Figures 3a, 3b and 6 for example show that the second clamping element flange 12 abuts against the second hemmed edge 20 limiting movement of the clamping element 2 out of the clamping volume 26 and therefore improving the positioning of the clamping element 2 in the clamping volume 26 when the clamping element 2 is mounted to the frame member 10.

[0060] Preferably, the second clamping element flange 12 is provided to mutually abut the second hemmed edge 20 at the second side 22 as well as the upright web 6 when the clamping element 2 is mounted to the frame member 10, as shown in figure 3a. The inventor has found that in such case the positioning of the clamping element 2 in the clamping volume 26 is even more improved since in addition to limiting the movement of the clamping element 2 out of the clamping volume 26 as described above, also movement of the clamping element 2 inside of the clamping volume 26 is limited such that the position of the second clamping element flange 12 in the clamping volume 26 becomes substantially fixed.

[0061] Preferably, the thickness of the second clamping element flange 12 does not substantially exceed the thickness of the second hemmed edge 20. The inventor has found that such a thickness of the second clamping element flange 12 substantially avoids fissures or openings between the ceiling tile 16 received and supported by the assembly of the frame member 10 and the clamping element 2 and the assembly of the frame member 10 and the clamping element 2 at the location of the clamping element 2. This way, the presence of an clamping element 2 does not substantially influence the look of the ceiling island.

[0062] Figures 4 and 5 show that the positioning means 4 comprise a first hemmed edge 19 provided on the first profile flange 7 of the frame member 10. The first hemmed edge 19 comprises a part of the first profile flange 7 which is folded to extend along the first profile flange 7 onto a first inner face 24 of the first profile flange facing the clamping volume 26. The first hemmed edge 19 is provided to cooperate with the clamping means 3 to position the clamping element 2 in the clamping volume 26 between the first 7 and the second 8 profile flange along the extending direction when mounted to the frame member 10.

[0063] Figure 4 and 5 show that the positioning means 4 comprise a connection member 23 extending towards the first profile flange 7 which is provided to be received between the first profile flange 7 and the first hemmed edge 19 of the frame member 10 when the clamping element 2 is mounted to the frame member 10. The inventor has found that the connection member 23 further limits the movement of the clamping element 2 out of the clamping volume 26 and therefore improves the positioning of the clamping element 2 in the clamping volume 26 when the clamping element 2 is mounted to the frame member

10.

[0064] Preferably, as shown in figure 4, the connection member 23 is provided on the clamping means 3, more preferably on the first clamping element flange 11. The connection member 23 preferably comprises a lip cut out off the first clamping element flange 11 and bent in an upward direction, as for example shown in figure 1 a. Any other connection member 23 is however also possible such as for example a separate piece mounted to the first clamping element flange 11, for example a metal piece, attached to the first profile flange 11 by soldering, welding, gluing, bolting, etc.

[0065] Preferably, the first flange 11 is provided to abut the upright web 6 at the first side 21 when the clamping element 2 is mounted to the frame member 10, as shown in figure 3a. The inventor has found that in such case the positioning of the clamping element 2 in the clamping volume 26 is improved since movement of the clamping element 2 inside of the clamping volume 26 is limited such that the position of the first clamping element flange 11 in the clamping volume 26 becomes substantially fixed. More preferably, the connection member 23 is received between the first profile flange 7 and the first hemmed edge 19 of the frame member 10 while the first clamping element flange 11 abuts the upright web at the first side 21 when the clamping element 2 is mounted to the frame member 10 such that the positioning of the first clamping element flange 11, and therefore of the clamping element 2, further improves.

[0066] Preferably, the connection member 23 is provided to cooperate with the clamping means 3 when the clamping element 2 is mounted to the frame member 10 such that clamping of the clamping element 2 is improved. Preferably, the connection member 23 has such a form and dimension that the connection member 23 snaps behind the first hemmed edge 19 when moving the clamping element 2 into the clamping volume 26 after placing the second clamping element flange 12 in an abutting position to the second hemmed edge 20. Alternatively, the connection member 23 has such a form and dimension that the first hemmed edge 19 snaps before the connection member 23 when moving the clamping element 2 into the clamping volume 26 after placing the second clamping element flange 12 in an abutting position to the second hemmed edge 20.

[0067] Preferably, the height with which the connection member 23 extends towards the first profile flange 7 is such that the first clamping element flange 11 runs substantially along the first profile flange 7, as described above.

[0068] Preferably, the clamping element 2 comprises fixing means 27 for fixing the position of the clamping element 2 along the longitudinal direction of the upright web 6 when the clamping element 2 is mounted to the frame member 10.

[0069] The clamping element 2 can for example be bolted, nailed, screwed, welded, soldered, etc. to the frame member. Figures 2a, 3a, 4 and 5 for example show

that the clamping element 2 is bolted to the frame member 10. The clamping element 2 thereto preferably is provided with at least one opening provided to receive the bolt, nail, staple, etc. As shown in figures 2a, 3a, 4 and 5 the clamping element 2, more preferably the third clamping element flange 13, comprises at least one additional sixth clamping element flange in which an opening provided to receive the bolt, nail, staple etc. is provided. Figures 2a, 3a, 4 and 5 show that two such sixth flanges are provided to the clamping element 2 each provided at an opposing upright side of the third clamping element flange 13. The number of sixth clamping element flanges, their position, location, form and dimension is however not critical for the invention and can be determined by the person skilled in the art.

[0070] Figure 3a, 4 and 5 for example show that when the clamping element 2 is mounted to the frame member 10 adjacent to an interconnecting piece 30, the interconnecting piece 30 preferably is provided to receive the sixth clamping flange of the clamping element 2n such that the clamping element can be provided closer to the interconnecting element 30.

Claims

1. A suspendable ceiling island system (1), comprising

- at least one frame member (10) for forming a frame (9) at least partly delimiting a ceiling island (1) comprising at least one ceiling tile (16), the frame member (9) comprising a longitudinally extending upright web (6) with a first (7) and second (8) longitudinally extending profile flange mounted along opposite respective first (17) and second (18) longitudinal sides of the upright web (6) and pointing away from the upright web (6) from the respective first (17) and second (18) longitudinal side along an extending direction,
- a clamping element (2) comprising clamping means (3) for mounting the clamping element (2) to the frame member (10) by clamping the clamping element (2) in a clamping volume (26) delimited by the first (7) and the second (8) profile flanges and the upright web (6) such that an assembly of the frame member (10) and the clamping element (2) is formed, the clamping element (2) when mounted to the frame member (10) being substantially located in the clamping volume (26), the clamping element (2) comprising suspending means (5) for suspending the frame (9), the suspending means (5) extending from the clamping volume (26) when the clamping element (2) is mounted to the frame member (10) and in that the assembly of the frame member (10) and the clamping element (2) is provided to receive and support at least part of the ceiling tile (16) the clamping means (3) further

comprising a third clamping element flange (13) provided to be positioned in the clamping volume (26) in an upright direction extending from the second profile flange (8) towards the first profile flange (7), a first clamping element flange (11) extending from a first side (21) of the third flange (13) and provided to extend towards the first profile flange (7) when the clamping element (2) is mounted to the frame member (10) and a second clamping element flange (12) extending from a second side (22) of the third flange (13) opposing the first side (21) of the third flange (13) and provided to extend towards the second profile flange (8) when the clamping element (2) is mounted to the frame member (10), the first (11), second (12) and third (13) clamping element flange being provided to clamp the clamping element (2) between the first (7) and the second (8) profile flanges such that an assembly of the frame member (10) and the clamping element (2) is formed

characterized in that the suspending means (5) extend in an upright direction from the end of the first clamping element flange (11), which end is situated opposite to the end of the first clamping element flange (11) that is connected to the third clamping element flange (13), such that the suspending means (5) protrudes above the plane defined by the first (7) profile flange when the clamping element (2) is mounted to the frame member (10) to form said suspendable ceiling island.

2. A suspendable ceiling island system (1) as claimed in claim 1, **characterized in that** the suspending means (5) comprise a fourth clamping element flange (14) extending directly from the end of the first clamping element flange (11), which end is situated opposite to the end of the first clamping element flange (11) that is connected to the third clamping element flange (13).
3. A suspendable ceiling island system (1) as claimed in any one of claims 1 - 2, **characterized in that** the first (11) clamping element flange runs along the first profile flange (7) when clamping the clamping element (2) between the first (7) and/or second (8) profile flange.
4. A suspendable ceiling island system (1) as claimed in any one of claims 1 - 3, **characterised in that** the first (11) and/or second (12) clamping element flange are provided to run substantially along the first (7) and/or second (8) profile flange when clamping the clamping element (2) between the first (7) and second (8) profile flange.
5. A suspendable ceiling island system as claimed in

any one of claims 1 - 4, **characterized in that** the third clamping element flange (13) is provided to run substantially along the upright web (6) when clamping the clamping element (2) between the first (7) and second (8) profile flange.

6. A suspendable ceiling island system (1) as claimed in any one of the preceding claims, **characterized in that** the assembly of the frame member (10) and the clamping element (2) comprises positioning means (4) for positioning the clamping element (2) between the first (7) and the second (8) profile flange along the extending direction when mounted to the frame member (10).

7. A suspendable ceiling island system (1) as claimed in claim 6, **characterized in that** the positioning means (4) for positioning the clamping member in the clamping volume comprise a second hemmed edge (20) provided on the second profile flange (8) of the frame member (10), the second hemmed edge (20) comprising a part of the second profile flange (8) which is folded to extend along the second profile flange (8) onto a second inner face (25) of the second profile flange (8) facing the clamping volume (26), the second hemmed edge (20) being provided to cooperate with the clamping means (3) to position the clamping element (2) in the clamping volume (26) along the extending direction when mounted to the frame member (10).

8. A suspendable ceiling island system (1) as claimed in any one of claims 6 - 7, **characterized in that** the positioning means (4) for positioning the clamping member in the clamping volume comprise a first hemmed edge (19) provided on the first profile flange (7) of the frame member (10), the first hemmed edge (19) comprising a part of the first profile flange (7) which is folded to extend along the first profile flange (7) onto a first inner face (24) of the first profile flange (7) facing the clamping volume (26), the first hemmed edge (19) being provided to cooperate with the clamping means (3) to position the clamping element (2) in the clamping volume (26) along the extending direction when mounted to the frame member (10).

9. A suspendable ceiling island system (1) as claimed in any one of claims 6 - 8, **characterized in that** the positioning means (4) comprise a connection member (23) extending from the first flange of the clamping means towards the first profile flange (7) and provided to be received between the first profile flange (7) and the first hemmed edge (19) of the frame member (10) when the clamping element (2) is mounted to the frame member (10).

10. A suspendable ceiling island system (1) as claimed in any one of claims 2 - 9, **characterized in that** the

suspending means (5) comprise a fifth clamping element flange (15) extending from the fourth clamping element flange (14) in a direction substantially along the extending direction when the clamping element (2) is mounted to the frame member (10).

11. A suspendable ceiling island system (1) as claimed in any one of the preceding claims, **characterized in that** the clamping element (2) comprises fixing means (27) for fixing the position of the clamping element (2) along the longitudinal direction of the upright web (6) when the clamping element (2) is mounted to the frame member (10).

Patentansprüche

1. Aufhängbares Deckeninselsystem (1), umfassend:

- mindestens ein Rahmenelement (10) zum Bilden eines Rahmens (9), der eine Deckeninsel (1), die mindestens eine Deckenplatte (16) umfasst, wenigstens teilweise begrenzt, wobei das Rahmenelement (9) einen sich der Länge nach erstreckenden aufrechten Steg (6) mit einem ersten (7) und zweiten (8) sich der Länge nach erstreckenden Profilflansch umfasst, die entlang gegenüberliegenden ersten (17) bzw. zweiten (18) Längsseiten des aufrechten Stegs (6) montiert sind und vom aufrechten Steg (6) von der ersten (17) bzw. zweiten (18) Längsseite entlang einer Erstreckungsrichtung wegzeigen,
- ein Klemmelement (2), umfassend Klemmmittel (3) zum Befestigen des Klemmelements (2) am Rahmenelement (10) durch Klemmen des Klemmelements (2) in einem Klemmvolumen (26), das durch die ersten (7) und zweiten (8) Profilflansche und den aufrechten Steg (6) derart begrenzt ist, dass eine Baugruppe des Rahmenelements (10) und des Klemmelements (2) gebildet wird, wobei sich das Klemmelement (2), wenn am Rahmenelement (10) befestigt, im Wesentlichen im Klemmvolumen (26) befindet, das Klemmelement (2) Aufhängemittel (5) zum Aufhängen des Rahmens (9) umfasst, die Aufhängemittel (5) sich vom Klemmvolumen (26) erstrecken, wenn das Klemmelement (2) am Rahmenelement (10) befestigt ist, und **dadurch**, dass die Baugruppe des Rahmenelements (10) und des Klemmelements (2) zum Aufnehmen und Tragen wenigstens eines Teils der Deckenplatte (16) vorgesehen ist, die Klemmmittel (3) ferner einen dritten Klemmelementflansch (13), der vorgesehen ist, um im Klemmvolumen (26) in einer aufrechten Richtung, die sich vom zweiten Profilflansch (8) in Richtung des ersten Profilflansches (7) erstreckt, positioniert zu sein, einen ersten Klem-

- melementflansch (11), der sich von einer ersten Seite (21) des dritten Flansches (13) erstreckt und vorgesehen ist, um sich in Richtung des ersten Profilflansches (7) zu erstrecken, wenn das Klemmelement (2) am Rahmenelement (10) befestigt ist, und einen zweiten Klemmelementflansch (12) umfassen, der sich von einer zweiten Seite (22) des dritten Flansches (13) gegenüber der ersten Seite (21) des dritten Flansches (13) erstreckt und vorgesehen ist, um sich in Richtung des zweiten Profilflansches (8) zu erstrecken, wenn das Klemmelement (2) am Rahmenelement (10) befestigt ist, wobei der erste (11), zweite (12) und dritte (13) Klemmelementflansch vorgesehen sind, um das Klemmelement (2) derart zwischen die ersten (7) und zweiten (8) Profilflansche zu klemmen, dass eine Baugruppe des Rahmenelements (10) und des Klemmelements (2) gebildet wird,
- dadurch gekennzeichnet, dass** sich die Aufhängemittel (5) in einer aufrechten Richtung vom Ende des ersten Klemmelementflansches (11) erstrecken, welches Ende sich gegenüber dem Ende des ersten Klemmelementflansches (11) befindet, das mit dem dritten Klemmelementflansch (13) verbunden ist, derart, dass das Aufhängemittel (5) über der Ebene vorsteht, die durch den ersten (7) Profilflansch definiert ist, wenn das Klemmelement (2) am Rahmenelement (10) befestigt ist, um die aufhängbare Deckeninsel zu bilden.
2. Aufhängbares Deckeninselsystem (1) nach Anspruch 1, **dadurch gekennzeichnet, dass** die Aufhängemittel (5) einen vierten Klemmelementflansch (14) umfassen, der sich direkt vom Ende des ersten Klemmelementflansches (11) erstreckt, welches Ende sich gegenüber dem Ende des ersten Klemmelementflansches (11) befindet, das mit dem dritten Klemmelementflansch (13) verbunden ist.
 3. Aufhängbares Deckeninselsystem (1) nach einem der Ansprüche 1 bis 2, **dadurch gekennzeichnet, dass** der erste (11) Klemmelementflansch beim Klemmen des Klemmelements (2) zwischen den ersten (7) und/oder zweiten (8) Profilflansch entlang des ersten Profilflansches (7) verläuft.
 4. Aufhängbares Deckeninselsystem (1) nach einem der Ansprüche 1 bis 3, **dadurch gekennzeichnet, dass** der erste (11) und/oder zweite (12) Klemmelementflansch so vorgesehen sind, dass sie beim Klemmen des Klemmelements (2) zwischen den ersten (8) und/oder zweiten (8) Profilflansch (7) im Wesentlichen entlang des ersten Profilflansches (7) und/oder zweiten (8) Profilflansches verlaufen.
 5. Aufhängbares Deckeninselsystem (1) nach einem

- der Ansprüche 1 bis 4, **dadurch gekennzeichnet, dass** der dritte Klemmelementflansch (13) so vorgesehen ist, dass er beim Klemmen des Klemmelements (2) zwischen den ersten (7) und/oder zweiten (8) Profilflansch im Wesentlichen entlang des aufrechten Stegs (6) verläuft.
6. Aufhängbares Deckeninselsystem (1) nach einem der vorhergehenden Ansprüche, **dadurch gekennzeichnet, dass** die Baugruppe des Rahmenelements (10) und des Klemmelements (2) Positionierungsmittel (4) zum Positionieren des Klemmelements (2) zwischen dem ersten (7) und dem zweiten (8) Profilflansch entlang der Erstreckungsrichtung, wenn am Rahmenelement (10) befestigt, umfasst.
 7. Aufhängbares Deckeninselsystem (1) nach Anspruch 6, **dadurch gekennzeichnet, dass** die Positionierungsmittel (4) zum Positionieren des Klemmelements im Klemmvolumen eine zweite umgeschlagene Kante (20) umfassen, die auf dem zweiten Profilflansch (8) des Rahmenelements (10) vorgesehen ist, wobei die zweite umgeschlagene Kante (20) einen Teil des zweiten Profilflansches (8) umfasst, welcher gefaltet ist, um sich entlang des zweiten Profilflansches (8) auf eine zweite Innenfläche (25) des zweiten Profilflansches (8) gegenüber dem Klemmvolumen (26) zu erstrecken, wobei die zweite umgeschlagene Kante (20) so vorgesehen ist, dass sie mit den Klemmmitteln (3) zum Positionieren des Klemmelements (2) im Klemmvolumen (26) entlang der Erstreckungsrichtung, wenn am Rahmenelement (10) befestigt, zusammenwirkt.
 8. Aufhängbares Deckeninselsystem (1) nach einem der Ansprüche 6 bis 7, **dadurch gekennzeichnet, dass** die Positionierungsmittel (4) zum Positionieren des Klemmelements im Klemmvolumen eine erste umgeschlagene Kante (19) umfassen, die auf dem ersten Profilflansch (7) des Rahmenelements (10) vorgesehen ist, wobei die erste umgeschlagene Kante (19) einen Teil des ersten Profilflansches (7) umfasst, welcher gefaltet ist, um sich entlang des ersten Profilflansches (7) auf eine erste Innenfläche (24) des ersten Profilflansches (8) gegenüber dem Klemmvolumen (26) zu erstrecken, wobei die erste umgeschlagene Kante (19) so vorgesehen ist, dass sie mit den Klemmmitteln (3) zum Positionieren des Klemmelements (2) im Klemmvolumen (26) entlang der Erstreckungsrichtung, wenn am Rahmenelement (10) befestigt, zusammenwirkt.
 9. Aufhängbares Deckeninselsystem (1) nach einem der Ansprüche 6 bis 8, **dadurch gekennzeichnet, dass** die Positionierungsmittel (4) ein Verbindungselement (23) umfassen, das sich vom ersten Flansch der Klemmmittel in Richtung des ersten Profilflansches (7) erstreckt und vorgesehen ist, um zwischen

dem ersten Profilflansch (7) und der ersten umgeschlagenen Kante (19) des Rahmenelements (10) aufgenommen zu werden, wenn das Klemmelement (2) am Rahmenelement (10) befestigt ist.

10. Aufhängbares Deckeninselsystem (1) nach einem der Ansprüche 2 bis 9, **dadurch gekennzeichnet, dass** die Aufhängemittel (5) einen fünften Klemmelementflansch (15) umfassen, der sich vom vierten Klemmelementflansch (14) in einer Richtung im Wesentlichen entlang der Erststreckungsrichtung erstreckt, wenn das Klemmelement (2) am Rahmenelement (10) befestigt ist.

11. Aufhängbares Deckeninselsystem (1) nach einem der vorhergehenden Ansprüche, **dadurch gekennzeichnet, dass** das Klemmelement (2) Fixiermittel (27) zum Fixieren der Position des Klemmelements (2) entlang der Längsrichtung des aufrechten Stegs (6) umfasst, wenn das Klemmelement (2) am Rahmenelement (10) befestigt ist.

Revendications

1. Système d'îlots de plafond suspendu (1), comprenant:

- au moins un élément de cadre (10) pour former un cadre (9) délimitant au moins en partie un îlot de plafond (1) comprenant au moins une dalle de plafond (16), l'élément de cadre (9) comprenant une âme verticale (6) s'étend longitudinalement avec une première (7) et une deuxième (8) aile de profilé s'étendant longitudinalement le long de premier (17) et deuxième (18) côtés longitudinaux respectifs de l'âme verticale (6) et s'écartant des premier (17) et deuxième (18) côtés longitudinaux respectifs de l'âme verticale (6) le long d'une direction d'extension,

- un élément de serrage (2) comprenant des moyens de serrage (3) pour monter l'élément de serrage (2) sur l'élément de cadre (10) en serrant l'élément de serrage (2) dans un volume de serrage (26) délimité par la première (7) et la deuxième (8) aile de profilé et l'âme verticale (6) de sorte qu'un assemblage de l'élément de cadre (10) et de l'élément de serrage (2) est formé, l'élément de serrage (2) étant, quand il est monté sur l'élément de cadre (10), substantiellement situé dans le volume de serrage (26), l'élément de serrage (2) comprenant des moyens de suspension (5) pour suspendre le cadre (9), les moyens de suspension (5) s'étendant à partir du volume de serrage (26) quand l'élément de serrage (2) est monté sur l'élément de cadre (10) et l'assemblage de l'élément de cadre (10) et de l'élément de serrage (2) étant

prévu pour recevoir et supporter au moins une partie de la dalle de plafond (16), les moyens de serrage (3) comprenant en outre une troisième aile (13) d'élément de serrage prévue pour être positionnée dans le volume de serrage (26) dans une direction verticale s'étendant de la deuxième aile (8) de profilé à la première aile (7) de profilé, une première aile (11) d'élément de serrage s'étendant à partir d'un premier côté (21) de la troisième aile (13) et prévue pour s'étendre vers la première aile (7) de profilé quand l'élément de serrage (2) est monté sur l'élément de cadre (10) et une deuxième aile (12) d'élément de serrage s'étendant à partir d'un deuxième côté (22) de la troisième aile (13) opposé au premier côté (21) de la troisième aile (13) et prévue pour s'étendre vers la deuxième aile (8) de profilé quand l'élément de serrage (2) est monté sur l'élément de cadre (10), les première (11), deuxième (12) et troisième (13) ailes d'élément de serrage étant prévues pour serrer l'élément de serrage (2) entre la première (7) et la deuxième (8) aile de profilé de sorte qu'un assemblage de l'élément de cadre (10) et de l'élément de serrage (2) est formé,

caractérisé en ce que les moyens de suspensions (5) s'étendent dans une direction verticale à partir de l'extrémité de la première aile (11) d'élément de serrage, laquelle extrémité est située à l'opposé de l'extrémité de la première aile (11) d'élément de serrage qui est raccordée à la troisième aile (13) d'élément de serrage, de sorte que le moyen de suspension (5) fait saillie au-dessus du plan défini par la première (7) aile de profilé quand l'élément de serrage (2) est monté sur l'élément de cadre (10) pour former ledit îlot de plafond suspendu.

2. Système d'îlots de plafond suspendu (1) tel que revendiqué dans la revendication 1, **caractérisé en ce que** les moyens de suspension (5) comprennent une quatrième aile (14) d'élément de serrage s'étendant directement à partir de l'extrémité de la première aile (11) d'élément de serrage, laquelle extrémité est située à l'opposé de l'extrémité de la première aile (11) d'élément de serrage qui est raccordée à la troisième aile (13) d'élément de serrage.

3. Système d'îlots de plafond suspendu (1) tel que revendiqué dans l'une quelconque des revendications 1 - 2, **caractérisé en ce que** la première aile (11) d'élément de serrage court le long de la première aile (7) de profilé quand l'élément de serrage (2) est serré entre la première (7) et / ou deuxième (8) aile de profilé.

4. Système d'îlots de plafond suspendu (1) tel que revendiqué dans l'une quelconque des revendications

- 1 - 3, **caractérisé en ce que** la première (11) et/ou deuxième (12) aile d'élément de serrage sont prévues pour courir sensiblement le long de la première (7) et / ou deuxième (8) aile de profilé quand l'élément de serrage (2) est serré entre la première (7) et la deuxième (8) aile de profilé.
5. Système d'îlots de plafond suspendu (1) tel que revendiqué dans l'une quelconque des revendications 1 - 4, **caractérisé en ce que** la troisième aile (13) d'élément de serrage est prévue pour courir sensiblement le long de l'âme verticale (6) quand l'élément de serrage (2) est serré entre la première (7) et la deuxième (8) aile de profilé.
6. Système d'îlots de plafond suspendu (1) tel que revendiqué dans l'une quelconque des revendications précédentes, **caractérisé en ce que** l'assemblage de l'élément de cadre (10) et de l'élément de serrage (2) comprend des moyens de positionnement (4) pour positionner l'élément de serrage (2) entre la première (7) et la deuxième (8) aile de profilé le long de la direction d'extension quand il est monté sur l'élément de cadre (10).
7. Système d'îlots de plafond suspendu (1) tel que revendiqué dans la revendication 6, **caractérisé en ce que** les moyens de positionnement (4) servant à positionner l'élément de serrage dans le volume de serrage comprennent une deuxième bord ourlé (20) prévu sur la deuxième aile (8) de profilé de l'élément de cadre (10), le deuxième bord ourlé (20) comprenant une partie de la deuxième aile (8) de profilé qui est pliée pour s'étendre le long de la deuxième aile (8) de profilé sur une deuxième face intérieure (25) de la deuxième aile (8) de profilé faisant face au volume de serrage (26), le deuxième bord ourlé (20) étant prévu pour coopérer avec les moyens de serrage (3) pour positionner l'élément de serrage (2) dans le volume de serrage (26) le long de la direction d'extension quand il est monté sur l'élément de cadre (10).
8. Système d'îlots de plafond suspendu (1) tel que revendiqué dans l'une quelconque des revendications 6 - 7, **caractérisé en ce que** les moyens de positionnement (4) servant à positionner l'élément de serrage dans le volume de serrage comprennent un premier bord ourlé (19) prévu sur la première aile (7) de profilé de l'élément de cadre (10), le premier bord ourlé (19) comprenant une partie de la première aile (7) de profilé qui est pliée pour s'étendre le long de la première aile (7) de profilé sur une première face intérieure (24) de la première aile de profilé faisant face au volume de serrage (26), le premier bord ourlé (19) étant prévu pour coopérer avec les moyens de serrage (3) pour positionner l'élément de serrage (2) dans le volume de serrage (26) le long de la direction
- d'extension quand il est monté sur l'élément de cadre (10).
9. Système d'îlots de plafond suspendu (1) tel que revendiqué dans l'une quelconque des revendications 6 - 8, **caractérisé en ce que** les moyens de positionnement (4) comprennent un élément de raccordement (23) s'étendant depuis la première aile des moyens de serrage vers la première aile (7) de profilé et prévu pour être reçu entre la première aile (7) de profilé et le premier bord ourlé (19) de l'élément de cadre (10) quand l'élément de serrage (2) est monté sur l'élément de cadre (10).
10. Système d'îlots de plafond suspendu (1) tel que revendiqué dans l'une quelconque des revendications 2 - 9, **caractérisé en ce que** les moyens de suspension (5) comprennent une cinquième aile (15) d'élément de serrage s'étendant depuis la quatrième aile (14) d'élément de serrage dans une direction sensiblement le long de la direction d'extension quand l'élément de serrage (2) est monté sur l'élément de cadre (10).
11. Système d'îlots de plafond suspendu (1) tel que revendiqué dans l'une quelconque des revendications précédentes, **caractérisé en ce que** l'élément de serrage (2) comprend des moyens de fixation (27) pour fixer la position de l'élément de serrage (2) le long de la direction longitudinale de l'âme verticale (6) quand l'élément de serrage (2) est monté sur l'élément de cadre (10).

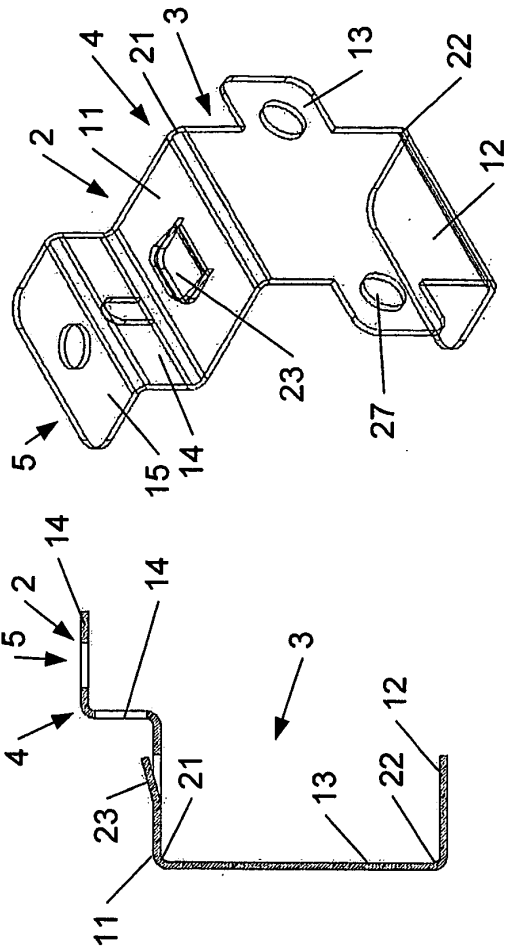

Fig. 1a

Fig. 1b

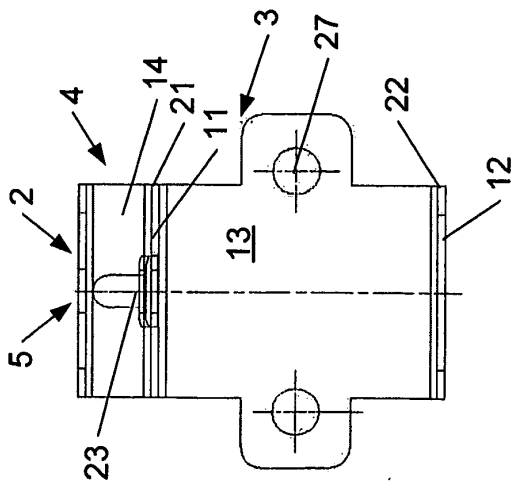

Fig. 1c

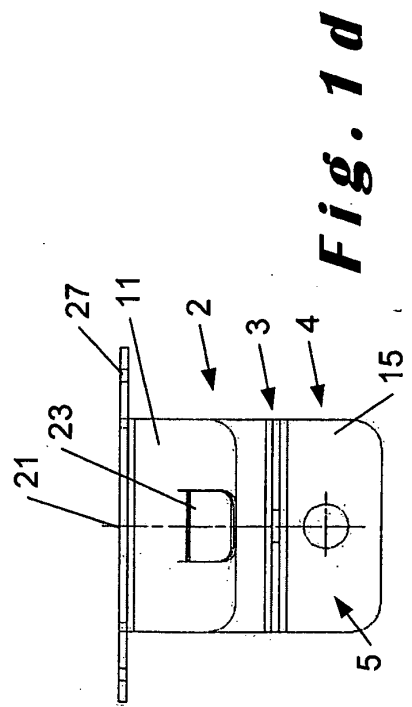

Fig. 1d

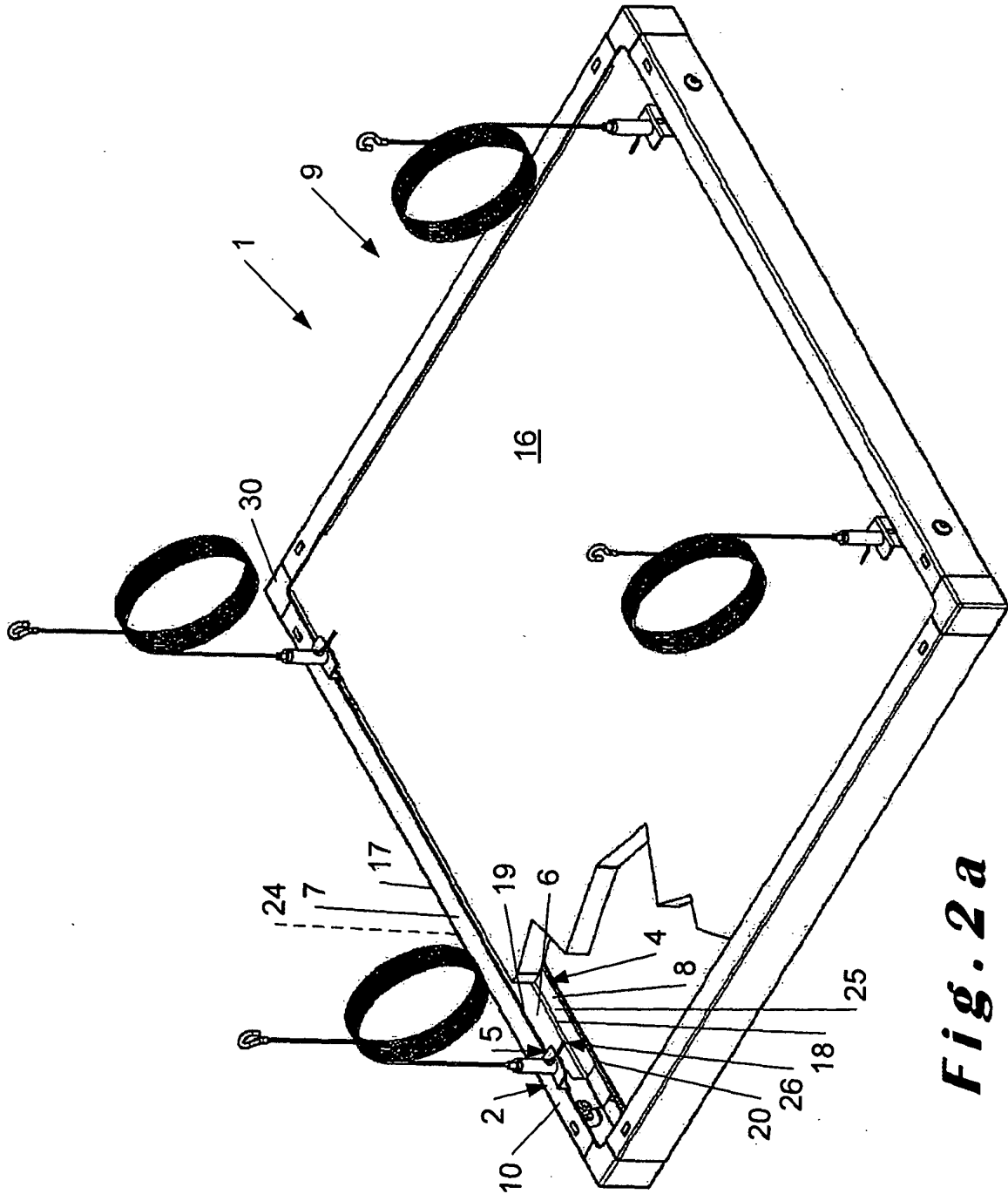

Fig. 2a

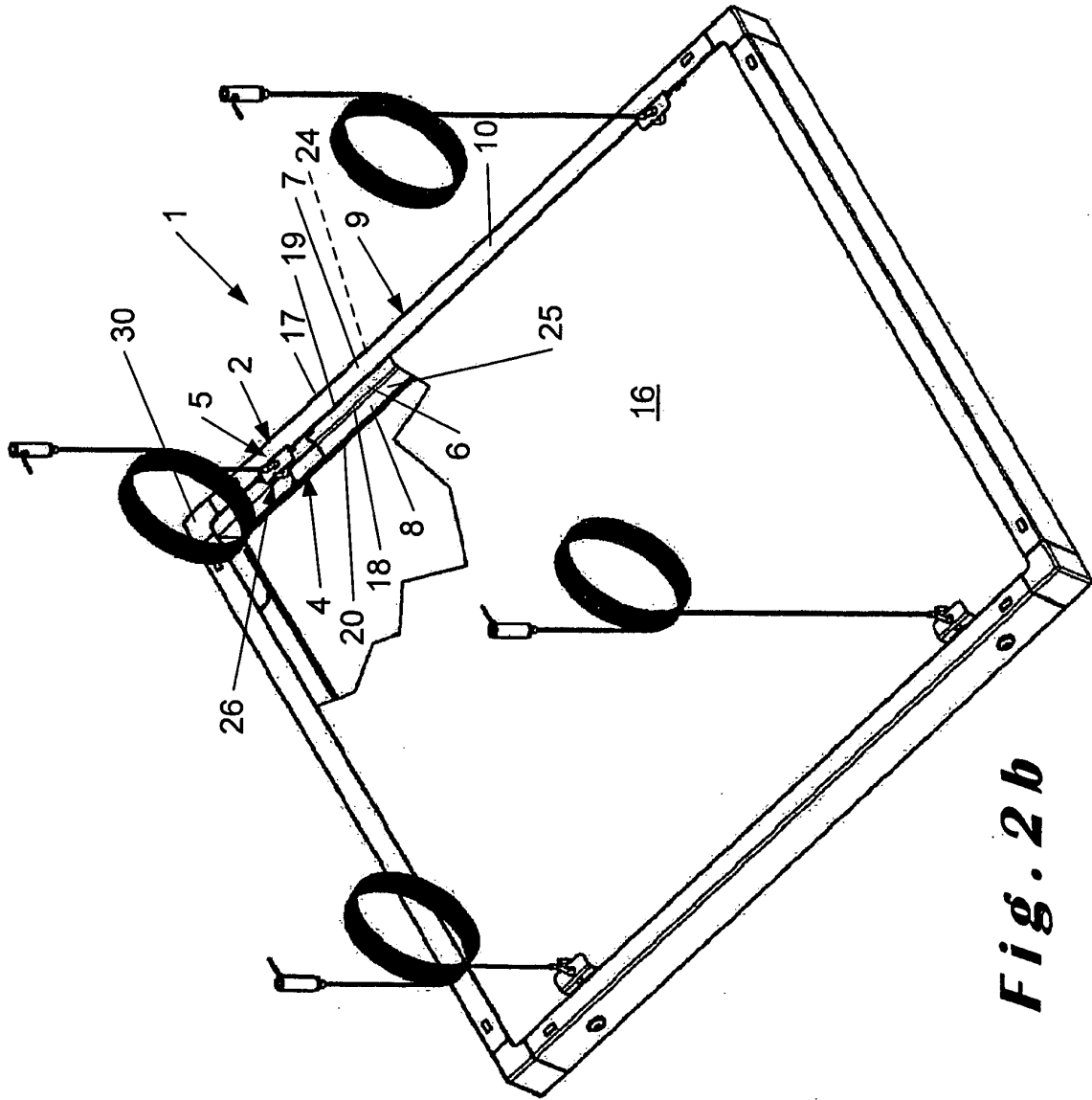

Fig. 2b

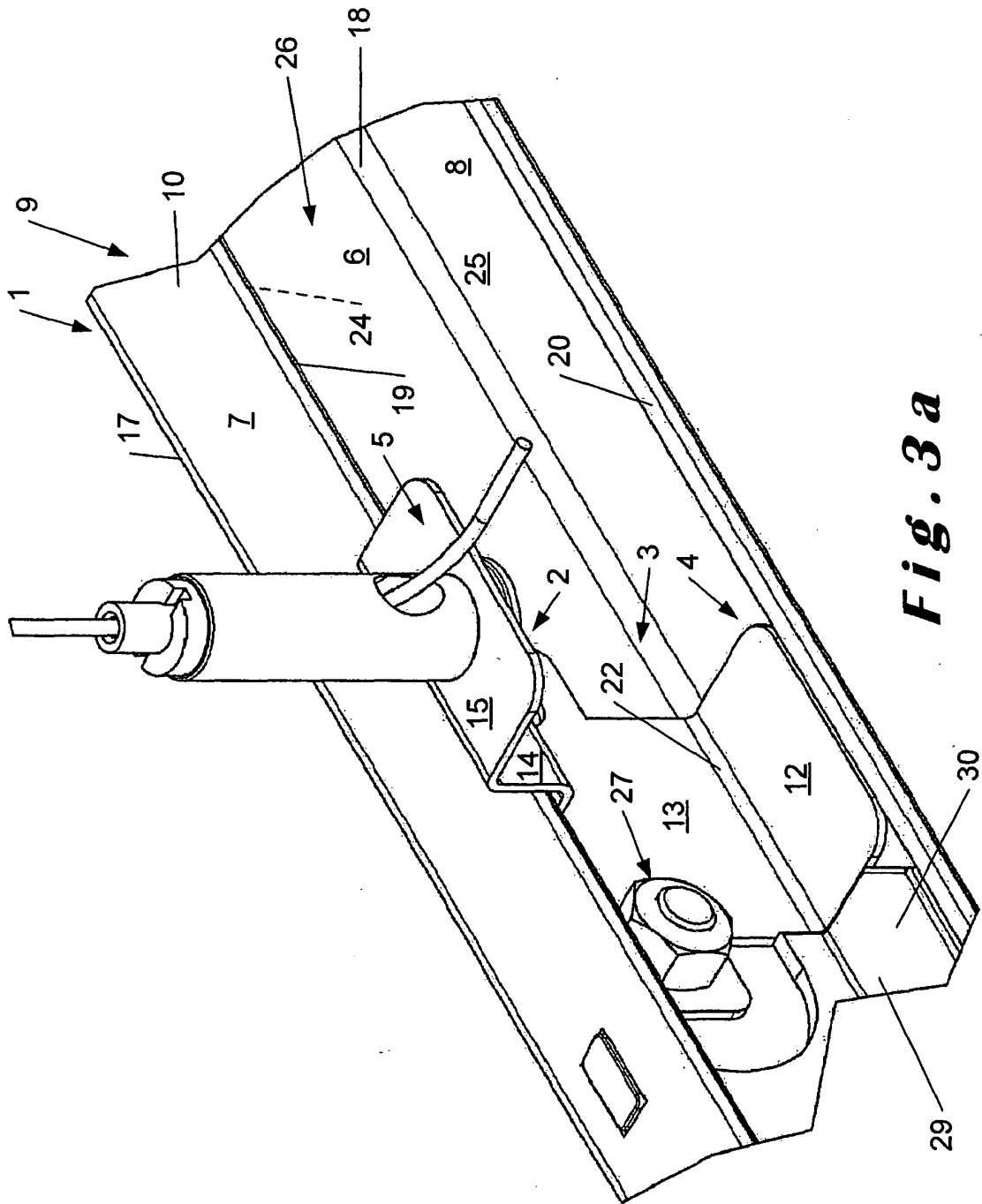

Fig. 3a

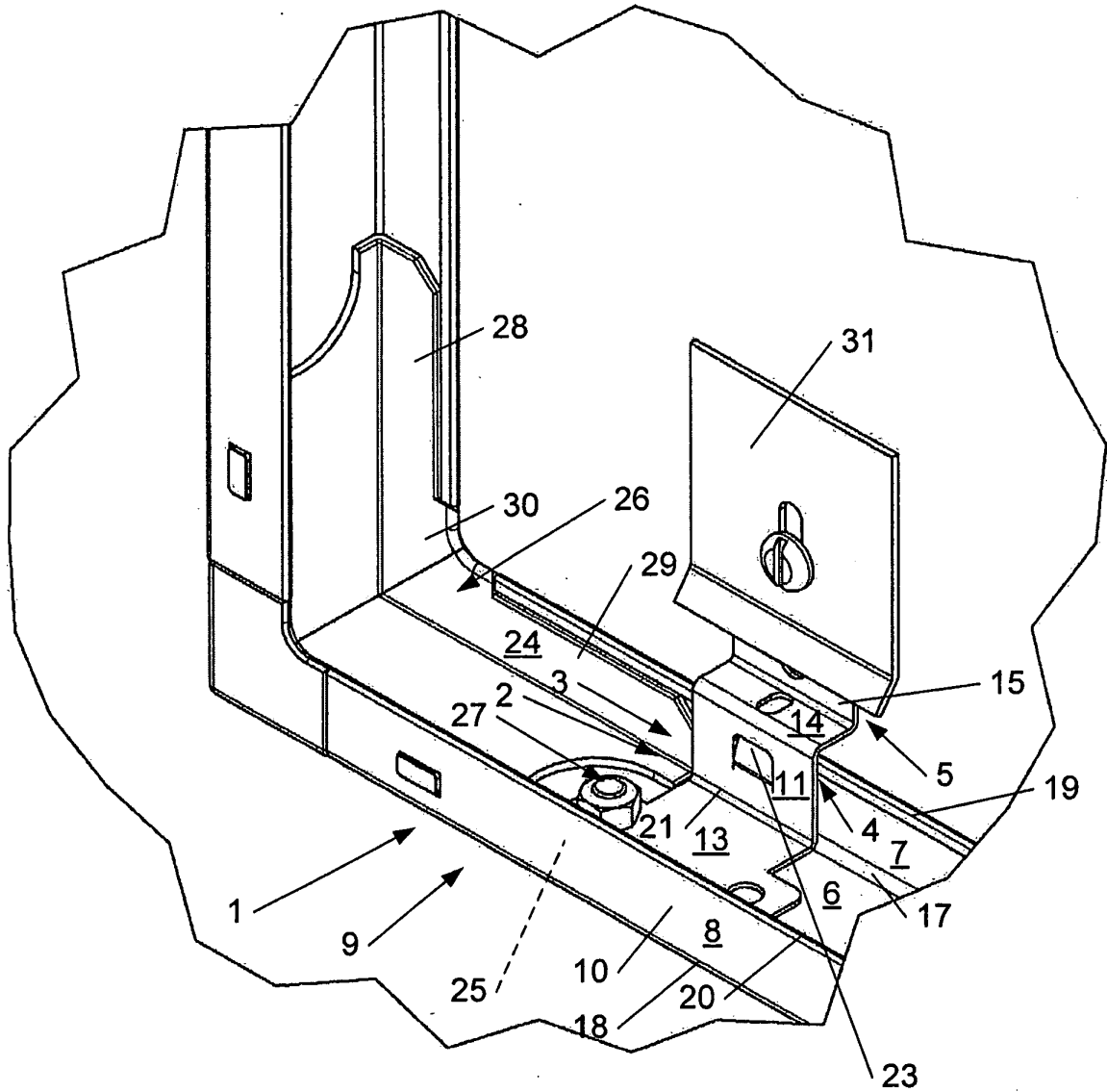

Fig. 4

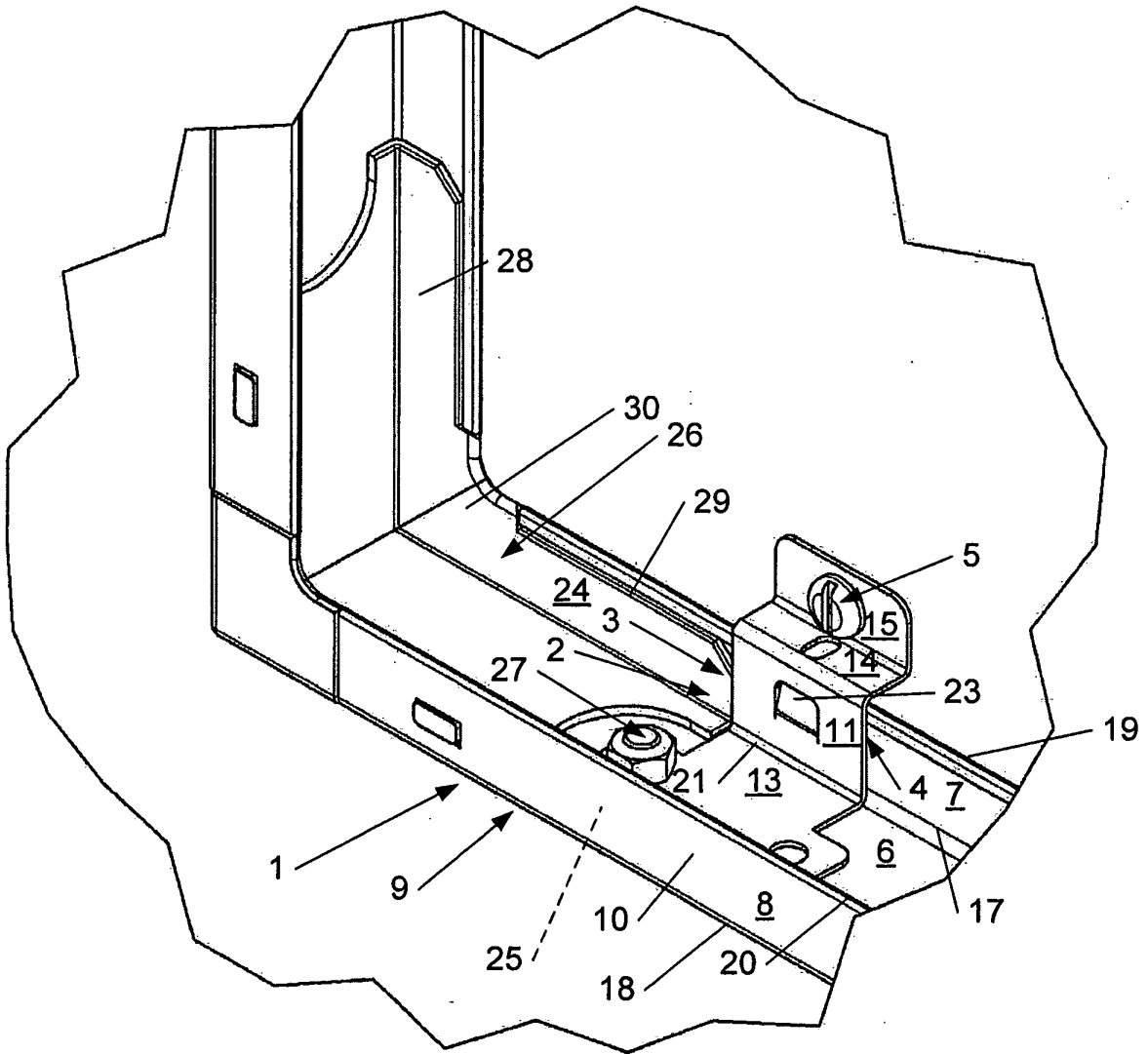

Fig. 5

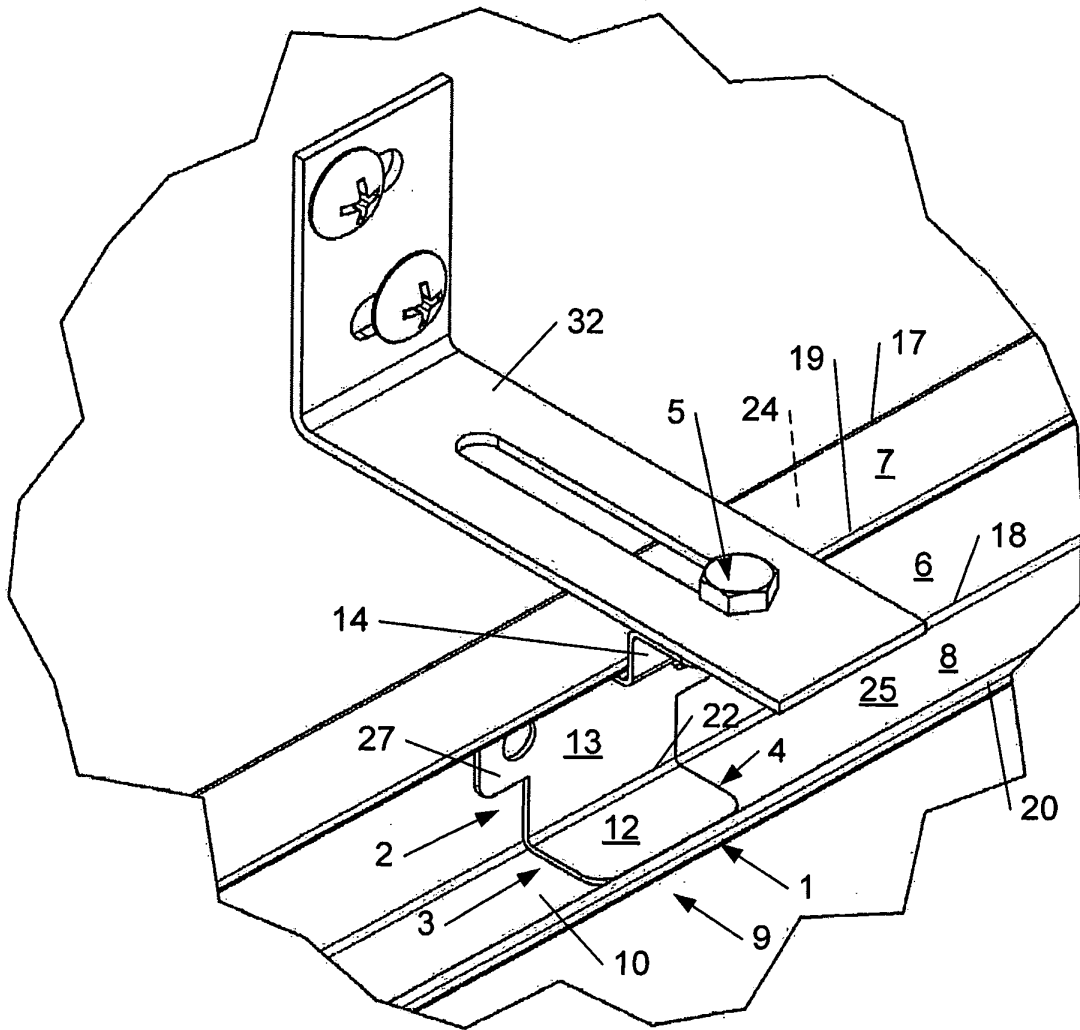

Fig. 6

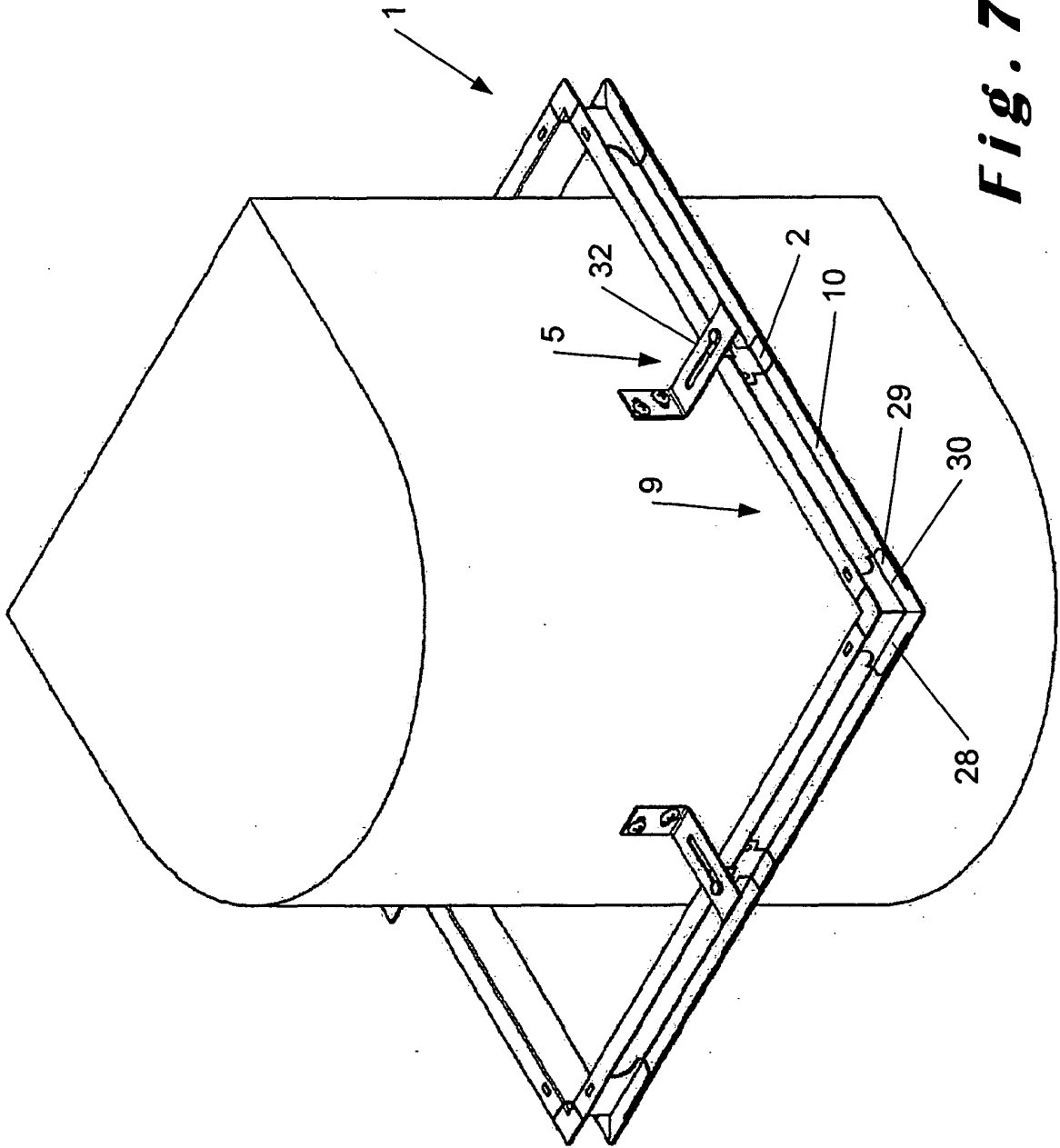

Fig. 7

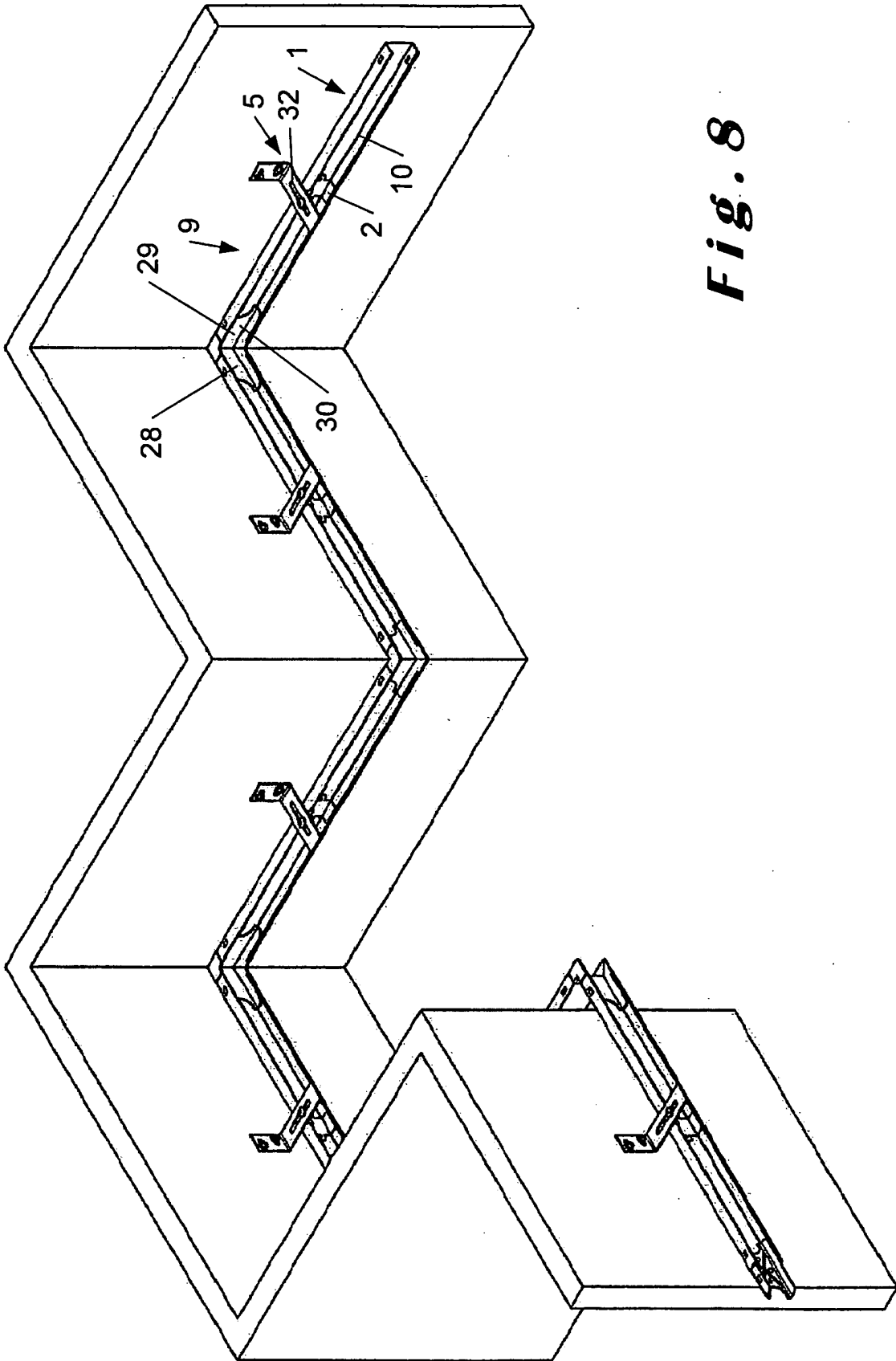

Fig. 8

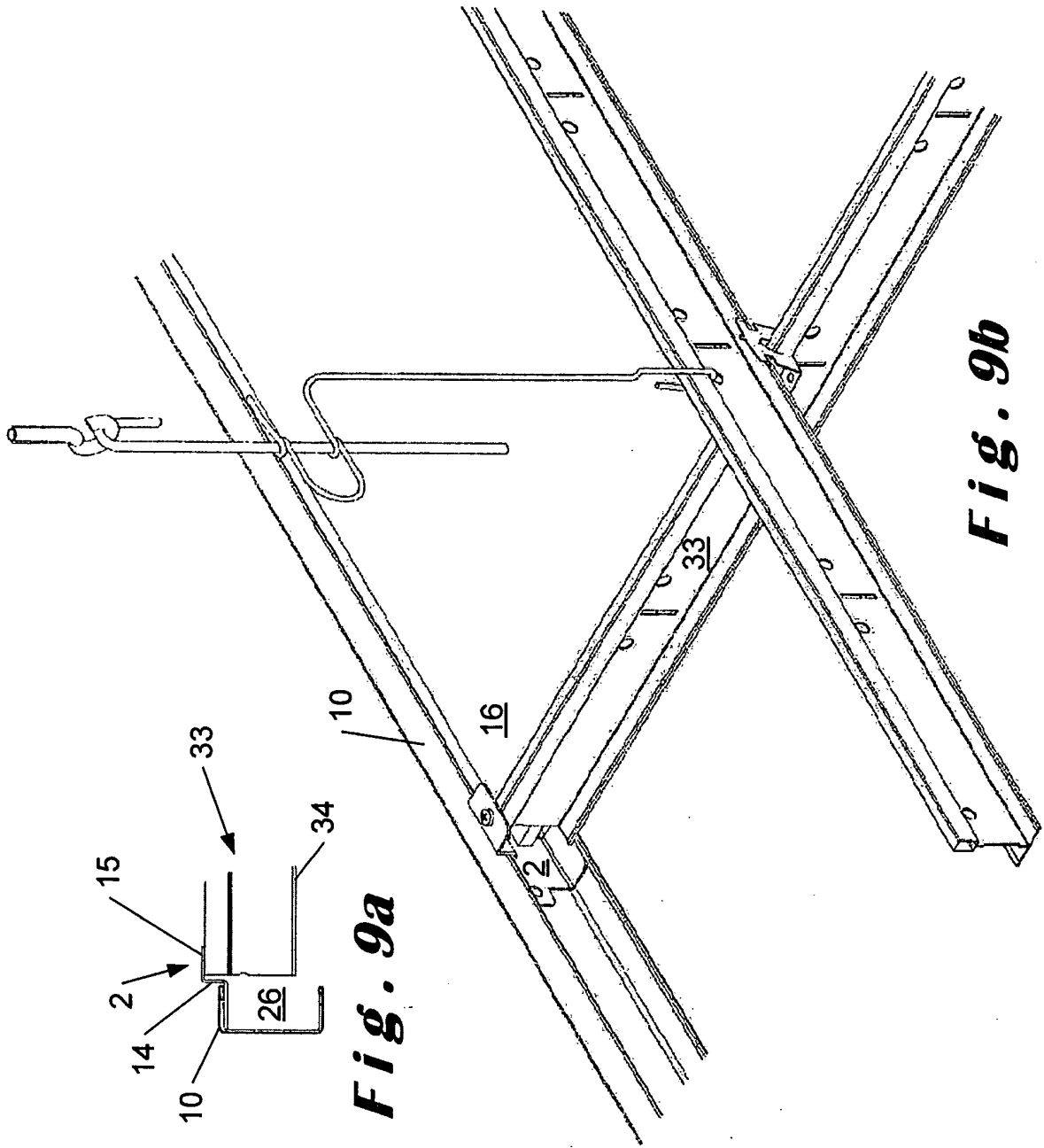

Fig. 9a

Fig. 9b

REFERENCES CITED IN THE DESCRIPTION

This list of references cited by the applicant is for the reader's convenience only. It does not form part of the European patent document. Even though great care has been taken in compiling the references, errors or omissions cannot be excluded and the EPO disclaims all liability in this regard.

Patent documents cited in the description

- EP 0516330 A2 [0002] [0003]
- EP 1811098 A1 [0056]