

(19) World Intellectual Property Organization
International Bureau



(43) International Publication Date
2 October 2008 (02.10.2008)

PCT

(10) International Publication Number
WO 2008/117092 A1

(51) International Patent Classification:
C09D 11/10 (2006.01) C09D 11/00 (2006.01)

(74) Agent: GILLARD, Richard; Prospect House, 8 Pembroke Road, Sevenoaks Kent TN13 1XR (GB).

(21) International Application Number:
PCT/GB2008/050219

(81) Designated States (unless otherwise indicated, for every kind of national protection available): AE, AG, AL, AM, AO, AT, AU, AZ, BA, BB, BG, BH, BR, BW, BY, BZ, CA, CH, CN, CO, CR, CU, CZ, DE, DK, DM, DO, DZ, EC, EE, EG, ES, FI, GB, GD, GE, GH, GM, GT, HN, HR, HU, ID, IL, IN, IS, JP, KE, KG, KM, KN, KP, KR, KZ, LA, LC, LK, LR, LS, LT, LU, LY, MA, MD, ME, MG, MK, MN, MW, MX, MY, MZ, NA, NG, NI, NO, NZ, OM, PG, PH, PL, PT, RO, RS, RU, SC, SD, SE, SG, SK, SL, SM, SV, SY, TJ, TM, TN, TR, TT, TZ, UA, UG, US, UZ, VC, VN, ZA, ZM, ZW.

(22) International Filing Date: 26 March 2008 (26.03.2008)

(25) Filing Language: English

(26) Publication Language: English

(30) Priority Data:
0705878.7 27 March 2007 (27.03.2007) GB

(71) Applicant (for all designated States except US): SERICOL LIMITED [GB/GB]; Patricia Way, Pysons Road Industrial Estate, Broadstairs Kent CT10 2LE (GB).

(84) Designated States (unless otherwise indicated, for every kind of regional protection available): ARIPO (BW, GH, GM, KE, LS, MW, MZ, NA, SD, SL, SZ, TZ, UG, ZM, ZW), Eurasian (AM, AZ, BY, KG, KZ, MD, RU, TJ, TM), European (AT, BE, BG, CH, CY, CZ, DE, DK, EE, ES, FI, FR, GB, GR, HR, HU, IE, IS, IT, LT, LU, LV, MC, MT, NL, NO, PL, PT, RO, SE, SI, SK, TR), OAPI (BF, BJ, CF, CG, CI, CM, GA, GN, GQ, GW, ML, MR, NE, SN, TD, TG).

(72) Inventors; and

(75) Inventors/Applicants (for US only): PRATT, Gareth [GB/GB]; Fujifilm Sericol Limited, Patricia Way, Pysons Road Industrial Estate, Broadstairs Kent CT10 2LE (GB). GOULD, Nigel [GB/GB]; Fujifilm Sericol Limited, Patricia Way, Pysons Road Industrial Estate, Broadstairs Kent CT10 2LE (GB).

Published:
— with international search report

(54) Title: A PRINTING INK

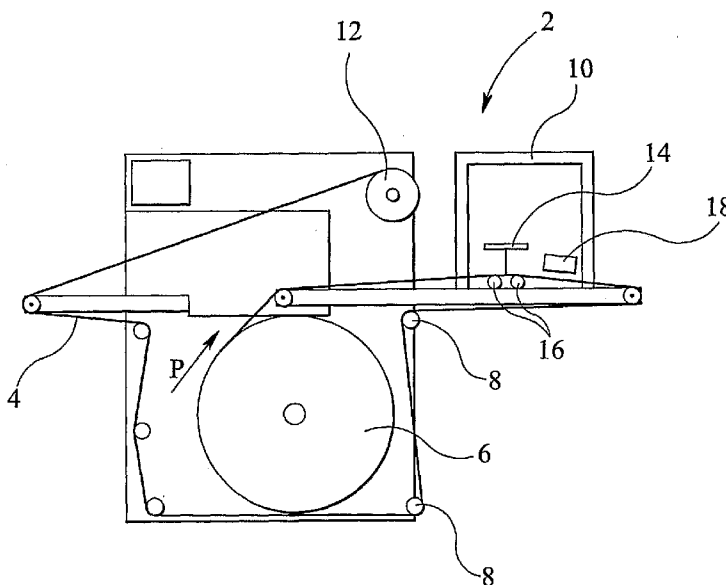

FIG 1

(57) Abstract: This invention relates to a radiation-curable ink-jet ink having a viscosity of 30 mPas or less at 25°C, the ink comprising: at least two monofunctional (meth)acrylate monomers which comprise a cyclic monofunctional (meth)acrylate monomer and 2-(2-ethoxyethoxy)ethyl acrylate; a monofunctional monomer selected from an N-vinyl amide, an N-acryloyl amine or a mixture thereof; a multifunctional (meth)acrylate monomer; a polymerisable (meth)acrylate oligomer; a radical photoinitiator; and a colouring agent. The ink is preferably used in reel-to-reel printing and in printing where the substrates are stacked.

WO 2008/117092 A1

A Printing Ink

This invention relates to a printing ink and in particular to inks for use in applications where blocking is an issue, such as reel-to-reel ink-jet printing.

5

In ink-jet printing, minute droplets of black, white or coloured ink are ejected in a controlled manner from one or more reservoirs or printing heads through narrow nozzles on to a substrate which is moving relative to the reservoirs. The ejected ink forms an image on the substrate. For high-speed printing, the inks must flow rapidly from the printing heads and, to ensure that this happens, they must have in use a low viscosity, typically no more than 100 mPas (cP) at 25°C although in most applications the viscosity should be no more than 50 mPas, and often no more than 30 mPas. Typically, when ejected through the nozzles, the ink has a viscosity of less than 25 mPas, preferably 10-12 mPas and ideally 10.5 mPas at the jetting temperature which is often elevated to about 40°C (the ink might have a much higher viscosity at ambient temperature). The inks must also be resistant to drying or crusting in the reservoirs or nozzles.

10
15

For these reasons, ink-jet inks for application at or near ambient temperatures are commonly formulated to contain a large proportion of a mobile liquid vehicle or solvent. In one common type of ink-jet ink this liquid is water - see for example the paper by Henry R. Kang in the Journal of Imaging Science, 35(3), pp. 179-188 (1991). In those systems, great effort must be made to ensure the inks do not dry in the head due to water evaporation. In another common type the liquid is a low-boiling solvent or mixture of solvents - see, for example, EP 0 314 403 and EP 0 424 714. Unfortunately, ink-jet inks that include a large proportion of water or solvent cannot be handled after printing until the inks have dried, either by evaporation of the solvent or its absorption into the substrate. This drying process is often slow and in many cases (for example, when printing on to a heat-sensitive substrate such as paper) cannot be accelerated.

20
25
30

Another type of ink-jet ink of the type used in the present invention contains unsaturated organic compounds, termed monomers, which polymerise by irradiation, commonly with ultraviolet light, in the presence of a photoinitiator. This type of ink

has the advantage that it is not necessary to evaporate the liquid phase to dry the print; instead the print is exposed to radiation to cure or harden it, a process which is more rapid than evaporation of solvent at moderate temperatures. In such ink-jet inks it is necessary to use monomers possessing a low viscosity.

5

Reel-to-reel printing places particular demands on the ink-jet ink. Fig. 1 shows a reel-to-reel printer 2. A substrate 4 is tightly wound on a substrate reel 6. The substrate reel 6 is caused to move in order to deliver the substrate 2, via guide reels 8, to the ink-jet printing station 10. The substrate 2 moves in the print direction P shown by the arrow. At the printing station 10, the ink is applied by printhead 14 shown schematically in Fig. 1. The stabilising reels 16 are positioned to provide a stable web onto which the ink is applied. As the substrate passes through the printing station 10, the ink is cured by a UV drier 18. The substrate 2 is subsequently accumulated on the receiving reel 12.

15

Reel-to-reel printing is a continuous process and therefore the substrate, and hence the ink printed thereon, only makes one pass under the radiation source, i.e. reel-to-reel printing is a single pass application. This results in the ink receiving a low dose of radiation, but at the same time the ink must cure quickly because of the speed at which the substrate travels from reel to reel. In addition, low-power pinning lamps are used between each printhead colour application (inter-colour pinning) since low power is needed to achieve dot gain requirements.

20

Since reel-to-reel printing is a single pass application, there is only one opportunity to achieve colour saturation. For this reason, high pigment loadings and/or high film weights are required. This places further demands on the nature of the radiation-curable components as high pigment loading and high film weights both work against absorption of the radiation by the components of the ink.

25

A consequence of reel-to-reel printing is that the substrate 2 is gathered on the receiving reel 12. The accumulation of layer upon layer of printed substrate causes significant temperatures and pressures to develop in the receiving reel and, as a result, the ink has a tendency to cause blocking, i.e. the ink has a tendency to cling to the

30

unprinted side of the substrate 2 as the receiving reel 12 is unwound. Avoidance of blocking is therefore essential in reel-to-reel printing inks.

5 It has also been found that the same problem occurs in automated and semi-automated printing processes using a flat-bed ink-jet printer where the substrate is loaded into the printer and the printer then prints and stacks the printed substrates upon one another. With automated processes, a significant pressure may build up under the weight of the printed substrates. Again, avoidance of blocking is therefore essential in printing inks designed for automated and semi-automated processes.

10

However, despite avoiding blocking, the ink must of course be capable of adhering to the substrate being printed which places competing demands on the ink formulation. Typical substrates are polyolefins, such as polypropylene and polyethylene, both with and without a topcoat which represent a further challenge for the ink formulator.

15

Against this background, the ink-jet ink must also satisfy the requirement of low viscosity which, as described above, is a general requirement for ink-jet inks. Achieving a low viscosity can be a particular challenge at high pigment loadings. The addition of oligomers, an essential component for enhancing scratch resistance, also tends increase viscosity.

20

There are therefore a number of competing factors in trying to formulate ink-jet inks suitable for reel-to-reel printing and other printing processes where blocking may be an issue, particularly on to polyolefin substrates. There remains a requirement in the art, therefore, for inks which achieve a balance between the competing factors of viscosity, cure speed, adhesion range and blocking resistance.

25

Accordingly, the present invention provides a radiation-curable ink-jet ink having a viscosity of 30 mPas or less at 25°C, the ink comprising:

30

at least two monofunctional (meth)acrylate monomers which comprise a cyclic monofunctional (meth)acrylate monomer and 2-(2-ethoxyethoxy)ethyl acrylate;
a monofunctional monomer selected from an N-vinyl amide, an N-acryloyl amine or a mixture thereof;
a multifunctional (meth)acrylate monomer;

a polymerisable (meth)acrylate oligomer;
a radical photoinitiator; and
a colouring agent.

- 5 It has been found that these factors can be balanced by the careful selection of the above-described components of the ink-jet ink formulation.

The present invention will now be described with reference to the drawing, in which Fig. 1 shows a printer for reel-to-reel printing.

10

The present invention is directed primarily to an ink-jet ink suitable for reel-to-reel printing and the printer described hereinabove with reference to Fig. 1 is suitable for use with the present ink.

- 15 The ink-jet ink of the present invention dries primarily by curing, i.e. by the polymerisation of the monomers and oligomers present, as discussed hereinabove, and hence is a radiation-curable ink. The ink does not, therefore, require the presence of water or a volatile organic solvent to effect drying of the ink, although the presence of such components may be tolerated. Preferably, however, the ink-jet ink of the present
20 invention is substantially free of water and volatile organic solvents.

As explained hereinabove, the ink formulator faces significant challenges in formulating ink-jet inks for reel-to-reel printing applications and applications where similar pressure is applied to the printed substrate. It has now been found that
25 combinations of certain monofunctional (meth)acrylate monomers, N-vinyl amide and/or N-acryloyl amine monomers, a multifunctional (meth)acrylate monomer and a polymerisable (meth)acrylate oligomer provide an excellent balance of viscosity, cure speed, adhesion range and blocking resistance.

- 30 The total amount of the at least two monofunctional (meth)acrylate monomers and the at least one monofunctional monomer selected from an N-vinyl amide, an N-acryloyl amine or a mixture thereof is preferably at least 25 wt% based on the total weight of the ink.

The cyclic monofunctional (meth)acrylate monomer is composed of an ester of acrylic or methacrylic acid in which the alcohol moiety is cyclic, i.e. the radical covalently bonded to the oxygen atom of the (meth)acrylate unit is cyclic. The cyclic radical may be saturated or unsaturated, including aromatic. The substituents are typically cycloalkyl, aryl and combinations thereof, any of which may be interrupted by heteroatoms. Non-limiting examples of substituents commonly used in the art include C₃₋₁₈ cycloalkyl, C₆₋₁₀ aryl and combinations thereof, such as C₆₋₁₀ aryl- or C₃₋₁₈ cycloalkyl-substituted C₁₋₁₈ alkyl, any of which may be interrupted by 1-10 heteroatoms, such as oxygen or nitrogen, with nitrogen further substituted by any of the above described substituents. Preferred cyclic monofunctional (meth)acrylates include the following monomers and mixtures thereof:

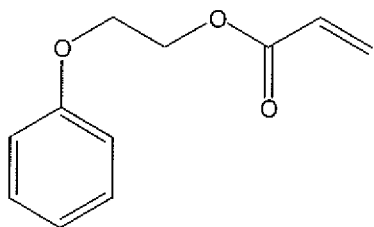

Phenoxyethyl acrylate (PEA)

15 mol wt 192

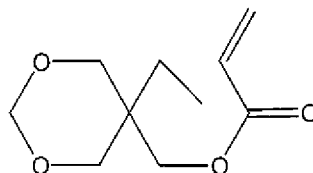

Cyclic TMP formal acrylate (CTFA)

mol wt 200

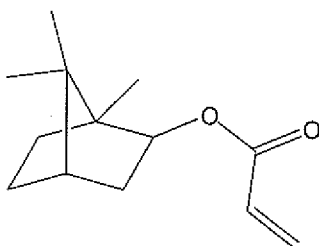

Isobornyl acrylate (IBOA)

mol wt 208

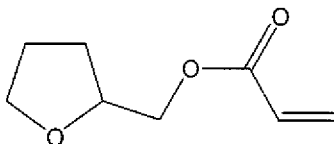

Tetrahydrofurfuryl acrylate (THFA)

mol wt 156

CTFA and PEA are preferred and PEA is particularly preferred in the ink-jet ink of the present invention. Thus, in a preferred embodiment, the present invention provides a radiation-curable ink-jet ink having a viscosity of 30 mPas or less at 25°C, the ink comprising: at least two monofunctional (meth)acrylate monomers which comprise a cyclic monofunctional (meth)acrylate monomer selected from CTFA and PEA, and 2-(2-ethoxyethoxy)ethyl acrylate; a monofunctional monomer selected from an N-vinyl amide, an N-acryloyl amine or a mixture thereof; a multifunctional

(meth)acrylate monomer; a polymerisable (meth)acrylate oligomer; a radical photoinitiator; and a colouring agent.

The total amount of the cyclic monofunctional (meth)acrylate monomer in the ink is preferably from 10 to 25 wt%, based on the total weight of the ink.

2-(2-Ethoxyethoxy)ethyl acrylate (EOEOEA) is a known monomer; it has a molecular weight of 188 and has the following formula:

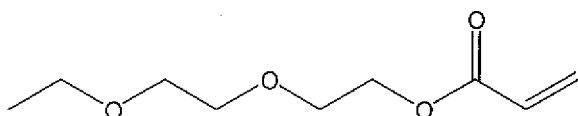

10

The total amount of 2-(2-ethoxyethoxy)ethyl acrylate in the ink is preferably from 5 to 15 wt%, based on the total weight of the ink.

N-Vinyl amides are well-known monomers in the art and a detailed description is therefore not required. N-Vinyl amides have a vinyl group attached to the nitrogen atom of an amide which may be further substituted in an analogous manner to the (meth)acrylate monomers.

Preferred examples are N-vinyl caprolactam (NVC) and N-vinyl pyrrolidone (NVP):

20

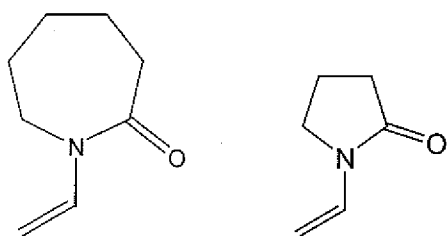

with NVC being particularly preferred.

25 Similarly, N-acryloyl amines are also well-known in the art. N-Acryloyl amines also have a vinyl group attached to an amide but via the carbonyl carbon atom and again may be further substituted in an analogous manner to the (meth)acrylate monomers.

Regarding the nomenclature, since the term “acryloyl” incorporates a carbonyl group, the amide is actually named as an amine.

A preferred example is N-acryloylmorpholine (ACMO):

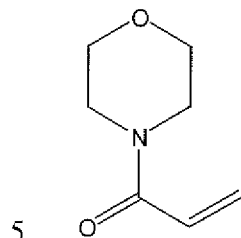

Thus, the monomer selected from an N-vinyl amide, an N-acryloyl amine or a mixture thereof, is preferably selected from N-vinyl caprolactam (NVC), N-vinyl pyrrolidone (NVP), N-acryloylmorpholine (ACMO) and mixtures thereof. The monomer selected from an N-vinyl amide, an N-acryloyl amine or a mixture thereof, is preferably present in the ink at a total amount of from 10 to 25 wt% based on the total weight of the ink.

The ink of the present invention also comprises a multifunctional (meth)acrylate monomer. Such monomers are well known in the art and have a functionality of two or higher and typically having a viscosity of less than 2 mPas at 25°C and a molecular weight of less than 450. Functionalities of two, three or four are preferred and preferably this monomer is a difunctional monomer. Preferred multifunctional (meth)acrylate monomers include dipropylene glycol diacrylate (DPGDA), hexanediol diacrylate (HDDA), tripropylene glycol diacrylate (TPGDA), propoxylated neopentyl glycol diacrylate (NPG(PO)DA) and mixtures thereof; a particularly preferred multifunctional (meth)acrylate monomer is dipropylene glycol diacrylate (DPGDA).

25 The total amount of the multifunctional (meth)acrylate monomer is from 5 to 15 wt% based on the total weight of the ink

The ink also contains a polymerisable (i.e. curable) (meth)acrylate oligomer. The term “polymerisable oligomer” has its standard meaning in the art, namely that the component is partially reacted to form a pre-polymer having a plurality of repeating

30

monomer units which is capable of further polymerisation. The oligomer is a curable, e.g. UV-curable, (meth)acrylate. The oligomer preferably has a molecular weight of at least 450. The molecular weight is preferably 4,000 or less, more preferably from 2,000 or less and most preferably 1500 or less. The degree of functionality of the oligomer determines the degree of crosslinking and hence the properties of the cured ink. The oligomer is preferably multifunctional meaning that it contains on average more than one reactive functional group per molecule. The average degree of functionality is preferably from 2 to 6, more preferably 2 to 4 and most preferably 3.

UV-curable oligomers of this type are well known in the art. The oligomer is preferably based on bisphenol A, a polyester, a polyether, an amine-modified polyester, an amine-modified polyethers or a urethane. Examples include Ebecryl® 81 and Ebecryl® 83 supplied by UCB Chemicals, and LR8869 and LR8996 supplied by BASF. A particularly preferred example is Ebecryl® 81 which is a polyether-acrylate oligomer having an average of 3 acrylate functional groups per molecule and a molecular weight of 600.

The total amount of the polymerisable (meth)acrylate oligomer is preferably from 5 to 35 wt% and most preferably from 15 to 30 wt%, based on the total weight of the ink.

Monomers may be distinguished from the oligomers on account of the lack of repeat units. The monomers typically have a molecular weight of less than 450 and more often less than 300.

It has been found that the above-described combination of a cyclic monofunctional (meth)acrylate monomer, 2-(2-ethoxyethoxy)ethyl acrylate, an N-vinyl amide and/or an N-acryloyl amine, a multifunctional (meth)acrylate monomer and a polymerisable (meth)acrylate oligomer provides an ink which has the desired properties for reel-to-reel printing and the like. It has been further found that the ink is preferably substantially free of acyclic-hydrocarbon monofunctional (meth)acrylate monomers. By substantially free is meant that trace amounts may be tolerated but this component is preferably avoided. Acyclic-hydrocarbon monofunctional (meth)acrylate monomers are known in the art and are composed of an ester of acrylic or methacrylic acid in which the alcohol moiety is an acyclic hydrocarbon, i.e. the radical covalently

bonded to the (meth)acrylate unit is an acyclic hydrocarbon. The acyclic-hydrocarbon radical may be saturated or unsaturated and contains no heteroatoms. The alkyl group is typically a C₆₋₂₀ alkyl group and common examples include octadecyl acrylate (ODA), tridecyl acrylate, isodecyl acrylate (IDA) and lauryl acrylate.

5

It is surprising that the selection of 2-(2-ethoxyethoxy)ethyl acrylate as the monofunctional (meth)acrylate monomer provides such improved properties over other monofunctional (meth)acrylate monomers and particularly over acyclic-hydrocarbon monofunctional (meth)acrylate monomers which are structurally similar and have similar physical properties. For example, ODA and EOEOEA have similar
10 molecular weights of 200 and 188, respectively, and similar glass transition temperatures for the homopolymers of -65°C and -54°C, respectively. However, as set out in the examples hereinbelow, EOEOEA outperforms ODA in reel-to-reel printing applications.

15

In addition to the components described hereinabove, the compositions include a photoinitiator which, under irradiation, for example by ultraviolet light, initiates the polymerisation of the monomers. Preferred are photoinitiators which produce free radicals on irradiation (free radical photoinitiators), such as benzophenone, 1-
20 hydroxycyclohexyl phenyl ketone, 2-benzyl-2-dimethylamino-(4-morpholinophenyl)butan-1-one, benzil dimethylketal, bis(2,6-dimethylbenzoyl)-2,4,4-trimethylpentylphosphine oxide or mixtures thereof. Such photoinitiators are known and commercially available such as, for example, under the trade names Irgacure, Darocur (from Ciba) and Lucerin (from BASF).

25

Preferably the photoinitiator is present from 1 to 20% by weight, more preferably from 5 to 15% by weight, based on the total weight of the ink.

The wavelength of the radiation and the nature of the photoinitiator system used must
30 of course coincide. The ink is cured by irradiation with actinic radiation, such as UV, x-ray, electron beam etc, although UV-curing is preferred.

The ink-jet ink of the present invention also includes a colouring agent, which may be either dissolved or dispersed in the liquid medium of the ink. Preferably the colouring

agent is a dispersible pigment. Commercially available colouring agents include those sold under the trade-names Paliotol (available from BASF plc), Cinquasia, Irgalite (both available from Ciba Speciality Chemicals) and Hostaperm (available from Clariant UK). The pigment may be of any desired colour such as, for example,
5 Pigment Yellow 13, Pigment Yellow 83, Pigment Red 9, Pigment Red 184, Pigment Blue 15:3, Pigment Green 7, Pigment Violet 19, Pigment Black 7. Especially useful are black and the colours required for trichromatic (CYM) process printing. Mixtures of pigments may be used.

10 The total proportion of pigment present is preferably from 0.5 to 15% by weight, more preferably from 1 to 10% by weight, based on the total weight of the ink.

Although the ink of the present invention cures by a free radical mechanism, the ink of the present invention may also be a so-called "hybrid" ink which cures by a radical
15 and cationic mechanism. The ink-jet ink of the present invention, in one embodiment, therefore further comprises at least one cationically curable monomer, such as a vinyl ether, and at least one cationic photoinitiator, such as an iodonium or sulfonium salt, e.g. diphenyliodonium fluoride and triphenylsulfonium hexafluorophosphate. Suitable cationic photoinitiators include the Union Carbide UVI-69-series, Deuteron UV 1240
20 and IJY2257, Ciba Irgacure 250 and CGI 552, IGM-C440, Rhodia 2047 and UV9380c.

Other components of types known in the art may be present in the ink to improve the properties or performance. These components may be, for example, surfactants,
25 defoamers, dispersants, synergists for the photoinitiator, stabilisers against deterioration by heat or light, reodorants, flow or slip aids, biocides and identifying tracers.

The present invention also provides a method of ink-jet printing using the above-described ink and a substrate having the cured ink thereon. Advantageously, the ink
30 may be used in reel-to-reel ink-jet printing. Accordingly, the present invention also provides a method of reel-to-reel ink-jet printing comprising printing the ink-jet ink as described herein on to a substrate and curing the ink as the substrate is caused to move from a substrate reel to a receiving reel. Alternatively, the ink may be used in an

automated or semi-automated process where the printed substrates are stacked one on top of another. Accordingly, the present invention also provides a method of ink-jet printing, comprising providing an ink-jet printer with a plurality of substrates, printing the ink-jet ink as defined herein on to a plurality of the substrates, curing the ink on each of the substrates to produce printed substrates, and stacking the printed substrates. Preferably the printer is a flat-bed ink-jet printer. The process may be semi-automated in that the substrates are fed manually in to the printer, or automated where the printer contains a substrate-storage facility having a plurality of substrates held therein.

10

Suitable substrates include polyolefin substrates, such as polyethylene and polypropylene, e.g. PE85 Trans T/C, PE85 White or PP Top White, polyethylene terephthalate (PET) and paper. Polyolefin substrates represent the most difficult of these substrates on which to gain adhesion.

15

The present invention also provides the use of the ink-jet ink as defined herein in applications which tend to cause blocking, i.e. where a block is formed comprising alternating layers of substrate and ink in contact with each other.

20 The ink of the present invention is cured by actinic, preferably ultraviolet, irradiation and is suitable for application by ink-jet printing.

The ink-jet ink exhibits a desirable low viscosity, i.e. 30 mPas or less, preferably 25 mPas or less and most preferably 22 mPas or less at 25°C. Viscosity may be determined using a Brookfield DV-I + running at 20 rpm.

(Meth)acrylate is intended herein to have its standard meaning, i.e. acrylate and/or methacrylate. Mono and multifunctional are also intended to have their standard meanings, i.e. "one" and "two or more" groups, respectively, which take part in the polymerisation reaction on curing. The substituents of the monofunctional and multifunctional monomers are not further limited other than by the constraints imposed by the use in an ink-jet ink, such as viscosity, stability, toxicity etc.

30

The inks of the invention may be prepared by known methods such as, for example, stirring with a high-speed water-cooled stirrer, or milling on a horizontal bead-mill.

Examples

5

The invention will now be described, by way of example, with reference to the following example (parts given are by weight).

Example 1

10

Inks 1-5 were prepared by combining the following components:

Component	Wt%	Function
N Vinyl caprolactam	16.10	Vinyl amide monomer
2 Phenoxy ethylacrylate	16.91	Cyclic monofunctional monomer
Monomer*	9.90	Monofunctional monomer
DPGDA	10.00	Difunctional monomer
Black pigment concentrate	5.29	Pigment
Irgacure 369	1.00	Photoinitiator
PBZ	4.00	Photoinitiator
Irgacure 907	0.40	Photoinitiator
Irgacure 184	2.00	Photoinitiator
TPO	4.50	Photoinitiator
ST-1	0.80	UV stabiliser
BYK 307	0.10	Silicone jetting aid
<u>Ebecryl 81</u>	<u>29.00</u>	Difunctional acrylate oligomer
Total	100.00	

* The additional monomer is:

15

Ink 1: PEA (Comparative)

Ink 2: PEA/TPO (Comparative)

Ink 3: DVE-3 (Comparative)

Ink 4: ODA (Comparative)

20 Ink 5: EOEOEA (Invention)

Example 2

The viscosity of the inks 1-5 prepared in Example 1 was measured and the inks were subsequently applied to a substrate and analysed. Viscosity was measured on a Brookfield DV-I + running at 20 rpm. The inks were drawn down onto to a 220 μm Genotherm (PVC) substrate using an M10 K bar applicator to give a film weight of approximately 8-10 μm . The films were cured using a Svecia UV drier fitted with two 80 W/cm lamps operating at full power with a belt speed of 20 m/min. The prints were left 15 hours after curing before the film properties were assessed. The results are shown in the following table:

Ink	1	2	3	4	5
Monomer	PEA	PEA/TPO	DVE-3	ODA	EOEOEA
Viscosity (mPas @ 25°C)	26.0	33.4	21.1	19.7	21.7

The base formulation of inks 1-5 as defined in Example 1 contains 29.00 wt% of the difunctional acrylate oligomer, Ebecryl 81. This relatively high level of oligomer leads to a significant rise in the viscosity of the base formulation. The viscosity reduction for inks 1 and 2 using more PEA (ink 1) and more PEA combined with TPO (ink 2) does not provide a sufficiently significant reduction in viscosity for these monomers to find application in reel-to-reel printing applications. However, the addition of DVE-3 (ink 3), ODA (ink 4) and EOEOEA (ink 5) provides a reduction in viscosity down to 21.1, 19.7 and 21.7 mPas, respectively, which is a sufficient reduction in viscosity.

Example 3

The adhesion of the inks 1-5 prepared in Example 1 was measured. The inks were cured under the conditions set out in Example 2 except that the substrates PE85 Trans T/C, PE85 White and PP Top White were used, as set out in the following table. The adhesion to these three different substrates was measured using tape adhesion from a cut edge. The sample print was scored through with a sharp knife and then adhesive tape was applied horizontally across the cut edges. The tape was then removed with a rapid tug and the degree of ink removal was assessed. The results are shown in the

following table in which “1” represents 100% removal of the cured ink and “5” represents 0% removal.

Ink			1	2	3	4	5
Monomer			PEA	PEA/TPO	DVE-3	ODA	EOEOEA
Substrate and % corona treatment*	PE85 Trans T/C	0	3	3	3	3	3
			3	3	3	3	3
			3	3	3	3	3
		20	3	<u>5</u>	3-4	<u>5</u>	<u>5</u>
			3	5	<u>5</u>	5	5
			3	5	5	5	5
		80	<u>5</u>	<u>5</u>	<u>5</u>	<u>5</u>	<u>5</u>
			5	5	5	5	5
			5	5	5	5	5
		100	<u>5</u>	<u>5</u>	<u>5</u>	<u>5</u>	<u>5</u>
			5	5	5	5	5
			5	5	5	5	5
	PE85 White	0	1	3	2-3	1	1-2
			1	3	2-3	1	1-2
			1	3	2-3	1	1-2
		20	1	3	3	3	3
			1	3	3	3	3
			1	3	3	3	3
		80	4	4	3	3-4	3-4
			<u>4-5</u>	<u>5</u>	3	<u>4-5</u>	<u>5</u>
			5	5	3	<u>5</u>	5
		100	<u>4-5</u>	3-4	3	4	<u>4-5</u>
			<u>4-5</u>	<u>5</u>	3	<u>4-5</u>	<u>5</u>
			<u>4-5</u>	5	3	<u>5</u>	5
	PP Top White	0	1	2-3	1-2	1	3
			3	3	1-2	3	3
			3	3	1-2	3	3
		20	3	<u>4-5</u>	<u>5</u>	3	3
			3	5	5	3	3
			3	5	5	3	3-4
		80	4	4	3	<u>4-5</u>	<u>5</u>
			<u>4-5</u>	<u>5</u>	3	4-5	5
			<u>4-5</u>	5	3	4-5	5
		100	3	3	4	3	4
			3	<u>5</u>	4	4	4
			3	5	<u>4-5</u>	<u>4-5</u>	4

5 * The values of 0, 20, 80 and 100 after the substrate indicate the level of corona treatment given to the substrate. The degree of corona treatment is stated as the percentage of the full corona discharge treatment given to the substrate, i.e. 0%, 20%,

80% or 100%. The greater the level of corona treatment given to a substrate the easier it is to gain adhesion.

As may be seen from the results achieved using PE85 White as the substrate, DVE-3
 5 does not provide sufficient adhesion.

Example 4

The blocking of the inks 1-5 prepared in Example 1 was measured. Coatings of 1, 2
 10 and 3 layers were blocked both print-to-print and print-to-substrate under a 20 Kg weight for 15 hours before being assessed for the degree of blocking. Although both print-to-print and print-to-substrate blocking were determined, for reel-to-reel printing applications only print-to-substrate is of particular relevance since the rolls formed will necessary be formed print-to-substrate. The results are shown in the following
 15 table in which “1” represents poor blocking performance and “5” represents excellent performance.

Ink	Monomer	Layer	Print-to-print	Print-to-substrate
1	PEA	1 layer	4	4
		2 layer	3	4
		3 layer	3/4	4
2	PEA + TPO	1 layer		
		2 layer	4	4
		3 layer	4	4
3	DVE-3	1 layer		
		2 layer		
		3 layer		
4	ODA	1 layer	3/4	3
		2 layer	4	3
		3 layer	3/4	4
5	EOEOEA	1 layer	4	4
		2 layer	4	5
		3 layer	4	4

The results show that the blocking performance of EOEOEA is superior to that of
 20 ODA, particularly in the important print-to-substrate tests.

Claims

1. A radiation-curable ink-jet ink having a viscosity of 30 mPas or less at 25°C, the ink comprising:
 - 5 at least two monofunctional (meth)acrylate monomers which comprise a cyclic monofunctional (meth)acrylate monomer and 2-(2-ethoxyethoxy)ethyl acrylate; a monofunctional monomer selected from an N-vinyl amide, an N-acryloyl amine or a mixture thereof;
 - a multifunctional (meth)acrylate monomer;
 - 10 a polymerisable (meth)acrylate oligomer;
 - a radical photoinitiator; and
 - a colouring agent.
2. An ink-jet ink as claimed in claim 1, wherein the total amount of the at least two monofunctional (meth)acrylate monomers and the at least one monofunctional
15 monomer selected from an N-vinyl amide, an N-acryloyl amine or a mixture thereof is at least 25 wt% based on the total weight of the ink.
3. An ink-jet ink as claimed in claim 1 or 2, wherein the total amount of the cyclic monofunctional (meth)acrylate monomer is from 10 to 25 wt%, based on the total weight of the ink.
- 20 4. An ink-jet ink as claimed in any preceding claim, wherein the total amount of 2-(2-ethoxyethoxy)ethyl acrylate is from 5 to 15 wt%, based on the total weight of the ink.
5. An ink-jet ink as claimed in any preceding claim, wherein the total amount of the monomer selected from an N-vinyl amide, an N-acryloyl amine or a mixture thereof is
25 from 10 to 25 wt% based on the total weight of the ink.
6. An ink-jet ink as claimed in any preceding claim, wherein the total amount of the multifunctional (meth)acrylate monomer is from 5 to 15 wt% based on the total weight of the ink.

7. An ink-jet ink as claimed in any preceding claim, wherein the total amount of the polymerisable (meth)acrylate oligomer is from 5 to 35 wt% based on the total weight of the ink.
8. An ink-jet ink as claimed in any preceding claim, wherein the cyclic monofunctional (meth)acrylate monomer is selected from phenoxyethyl acrylate (PEA), cyclic TMP formal acrylate (CTFA), isobornyl acrylate (IBOA), tetrahydrofurfuryl acrylate (THFA) and mixtures thereof.
9. An ink-jet ink as claimed in claim 8, wherein the cyclic monofunctional (meth)acrylate monomer is phenoxyethyl acrylate (PEA).
10. 10. An ink-jet ink as claimed in any preceding claim, wherein the monomer selected from an N-vinyl amide, an N-acryloyl amine or a mixture thereof, is selected from N-vinyl caprolactam (NVC), N-vinyl pyrrolidone (NVP), N-acryloylmorpholine (ACMO) and mixtures thereof.
11. An ink-jet ink as claimed in any preceding claim, wherein the multifunctional (meth)acrylate monomer is a difunctional monomer.
12. An ink-jet ink as claimed in any preceding claim, wherein the polymerisable (meth)acrylate oligomer has a molecular weight from 450 to 4,000.
13. An ink-jet ink as claimed in any preceding claim, wherein the polymerisable (meth)acrylate oligomer has a degree of functionality from 2 to 6.
- 20 14. An ink-jet ink as claimed in any preceding claim, wherein the ink is substantially free of acyclic-hydrocarbon monofunctional (meth)acrylate monomer.
15. A method of reel-to-reel ink-jet printing, comprising printing the ink-jet ink as claimed in any preceding claim on to a substrate and curing the ink as the substrate is caused to move from a substrate reel to a receiving reel.
- 25 16. A method of ink-jet printing, comprising providing an ink-jet printer with a plurality of substrates, printing the ink-jet ink as claimed in any of claims 1 to 14 on

to a plurality of the substrates, curing the ink on each of the substrates to produce printed substrates, and stacking the printed substrates.

17. A method as claimed in claim 16, wherein the printer contains a substrate-storage facility having a plurality of substrates held therein.

5 18. A method as claimed in claim 16, wherein the printer is a flat-bed ink-jet printer.

19. A method as claimed in any of claims 15 to 17, wherein the substrate is a polyolefin substrate.

20. A substrate having the ink-jet ink as claimed in any of claims 1 to 14 printed thereon.

10 21. A substrate as claimed in claim 20, wherein the substrate is a polyolefin substrate.

22. Use of the ink-jet ink as claimed in any of claims 1 to 14 in applications which tend to cause blocking.

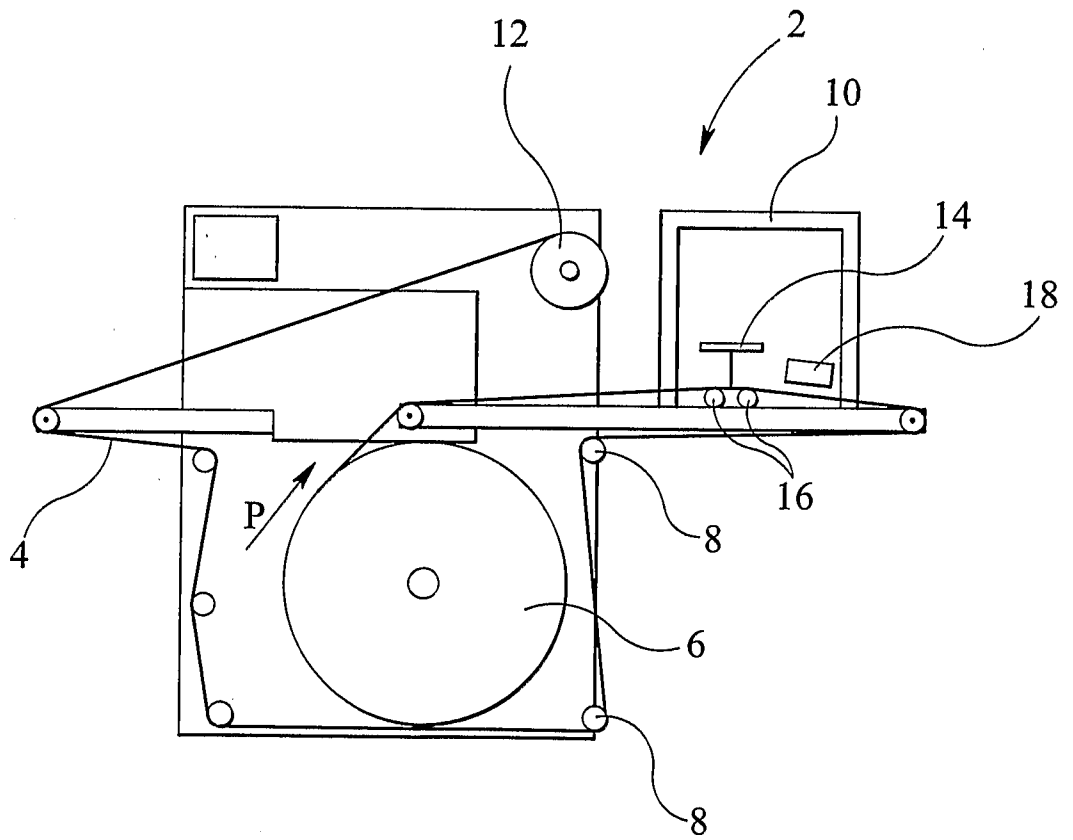

FIG 1

INTERNATIONAL SEARCH REPORT

International application No
PCT/GB2008/050219

A. CLASSIFICATION OF SUBJECT MATTER INV. C09D11/10 C09D11/00		
According to International Patent Classification (IPC) or to both national classification and IPC		
B. FIELDS SEARCHED		
Minimum documentation searched (classification system followed by classification symbols) C09D		
Documentation searched other than minimum documentation to the extent that such documents are included in the fields searched		
Electronic data base consulted during the international search (name of data base and, where practical, search terms used) EPO-Internal, WPI Data		
C. DOCUMENTS CONSIDERED TO BE RELEVANT		
Category*	Citation of document, with indication, where appropriate, of the relevant passages	Relevant to claim No.
X	EP 1 642 943 A (3M INNOVATIVE PROPERTIES CO [US]) 5 April 2006 (2006-04-05) examples; table 7	1-22
X	US 2002/086914 A1 (LEE JENNIFER L [US] ET AL) 4 July 2002 (2002-07-04) examples	1-22
A	WO 98/27171 A (MINNESOTA MINING & MFG [US]) 25 June 1998 (1998-06-25) examples	1-22
A	WO 99/29788 A (XAAR TECH LTD [GB]; JOHNSON STEVE [GB]; WOODS JILL [GB]) 17 June 1999 (1999-06-17) example 5	1-22
<input type="checkbox"/> Further documents are listed in the continuation of Box C. <input checked="" type="checkbox"/> See patent family annex.		
* Special categories of cited documents :		
A document defining the general state of the art which is not considered to be of particular relevance *E* earlier document but published on or after the international filing date *L* document which may throw doubts on priority claim(s) or which is cited to establish the publication date of another citation or other special reason (as specified) *O* document referring to an oral disclosure, use, exhibition or other means *P* document published prior to the international filing date but later than the priority date claimed	*T* later document published after the international filing date or priority date and not in conflict with the application but cited to understand the principle or theory underlying the invention *X* document of particular relevance: the claimed invention cannot be considered novel or cannot be considered to involve an inventive step when the document is taken alone *Y* document of particular relevance: the claimed invention cannot be considered to involve an inventive step when the document is combined with one or more other such documents, such combination being obvious to a person skilled in the art. *&* document member of the same patent family	
Date of the actual completion of the international search <p style="text-align: center; font-weight: bold;">19 June 2008</p>	Date of mailing of the international search report <p style="text-align: center; font-weight: bold;">30/06/2008</p>	
Name and mailing address of the ISA/ European Patent Office, P.B. 5818 Patentlaan 2 NL - 2280 HV Rijswijk Tel. (+31-70) 340-2040, Tx. 31 651 epo nl, Fax: (+31-70) 340-3016	Authorized officer <p style="text-align: center; font-weight: bold;">Zeslawski, Wojciech</p>	

INTERNATIONAL SEARCH REPORT

Information on patent family members

International application No

PCT/GB2008/050219

Patent document cited in search report	A	Publication date	Patent family member(s)	Publication date
EP 1642943	A	05-04-2006	NONE	
<hr style="border-top: 1px dashed black;"/>				
US 2002086914	A1	04-07-2002	AU 3060702	A 21-05-2002
			AU 2002230607	B2 29-06-2006
			CA 2425945	A1 16-05-2002
			CN 1484680	A 24-03-2004
			EP 1355999	A2 29-10-2003
			JP 2004514014	T 13-05-2004
			MX PA03003997	A 12-02-2004
			WO 0238688	A2 16-05-2002
<hr style="border-top: 1px dashed black;"/>				
WO 9827171	A	25-06-1998	AU 726387	B2 09-11-2000
			AU 5429098	A 15-07-1998
			CA 2275293	A1 25-06-1998
			CN 1240466	A 05-01-2000
			DE 69728162	D1 22-04-2004
			DE 69728162	T2 30-12-2004
			EP 0946662	A1 06-10-1999
			JP 2001506303	T 15-05-2001
			US 6232359	B1 15-05-2001
			US 5981113	A 09-11-1999
			ZA 9710475	A 20-05-1999
			<hr style="border-top: 1px dashed black;"/>	
WO 9929788	A	17-06-1999	AU 1346399	A 28-06-1999
			GB 2346889	A 23-08-2000
<hr style="border-top: 1px dashed black;"/>				