

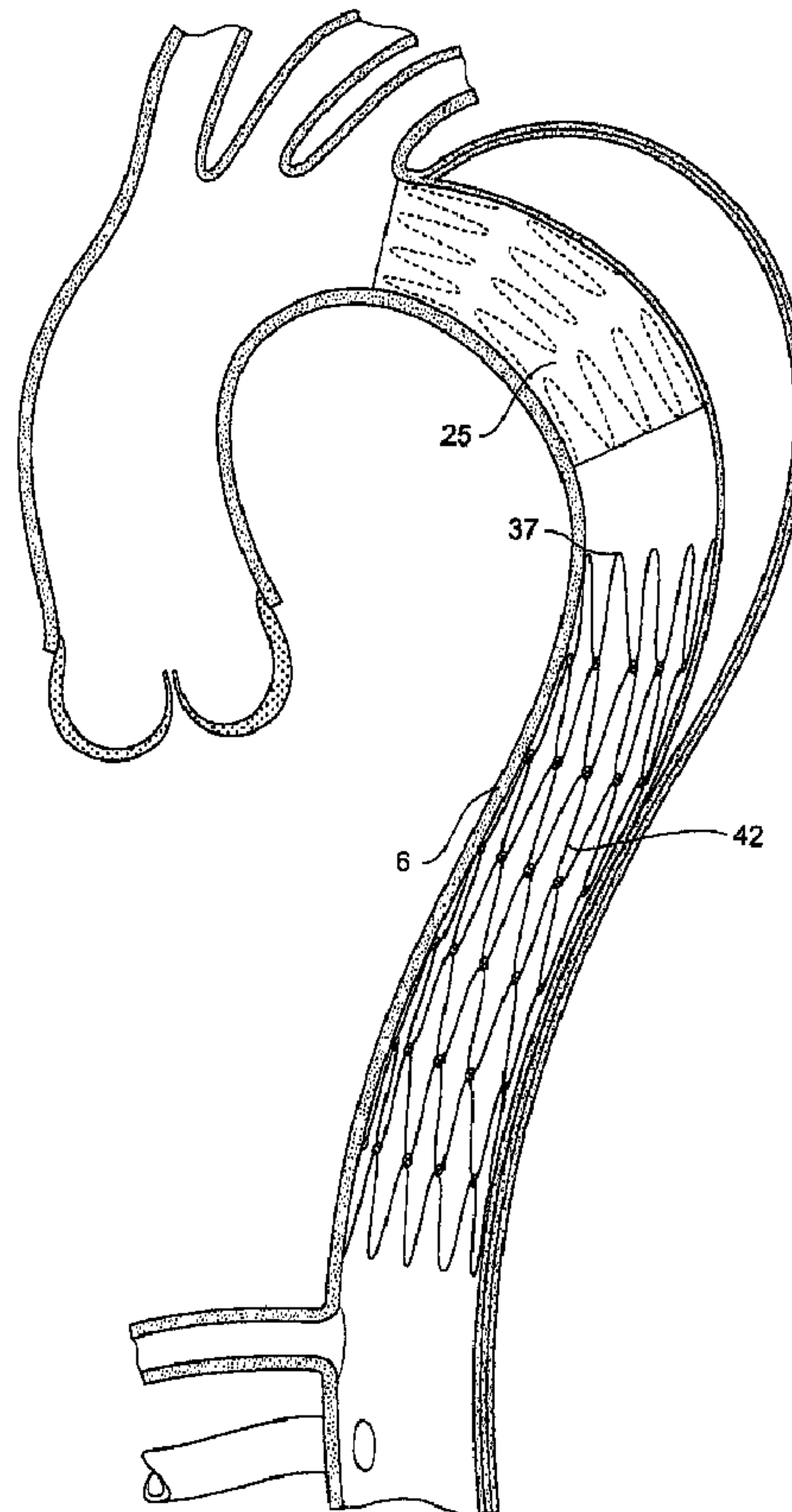

(86) Date de dépôt PCT/PCT Filing Date: 2005/09/28
 (87) Date publication PCT/PCT Publication Date: 2006/04/06
 (45) Date de délivrance/Issue Date: 2013/07/16
 (85) Entrée phase nationale/National Entry: 2007/03/27
 (86) N° demande PCT/PCT Application No.: US 2005/034965
 (87) N° publication PCT/PCT Publication No.: 2006/037086
 (30) Priorité/Priority: 2004/09/28 (US60/613,950)

(51) Cl.Int./Int.Cl. *A61F 2/07* (2013.01),
A61F 2/89 (2013.01), *A61F 2/95* (2013.01)
 (72) Inventeurs/Inventors:
 HARTLEY, DAVID ERNEST, AU;
 RASMUSSEN, ERIK E., DK;
 MCINTYRE, THOMAS C., AU
 (73) Propriétaires/Owners:
 WILLIAM A. COOK AUSTRALIA PTY. LTD., AU;
 COOK MEDICAL TECHNOLOGIES LLC, US
 (74) Agent: KIRBY EADES GALE BAKER

(54) Titre : DISPOSITIF PERMETTANT DE TRAITER LES ANEURISMES DISSEQUANTS
 (54) Title: DEVICE FOR TREATING AORTIC DISSECTION



(57) Abrégé/Abstract:

A stent assembly adapted for endoluminal placement by endovascular deployment for the treatment of a false lumen associated with a vascular dissection. The stent assembly has a number of self expanding stents connected together to define an elongate



(57) **Abrégé(suite)/Abstract(continued):**

substantially cylindrical lumen wall engaging surface. The stents are adapted to provide pressure on the wall of the lumen adjacent to and extending away from a rupture. A deployment device for the stent assembly includes a sheath and a retention and release arrangement to retain the proximal end of the stent graft to the deployment device. Release of the stent assembly is by withdrawal of the sheath before release of its proximal end by the use of a trigger wire of the retention and release arrangement.

ABSTRACT

A stent assembly adapted for endoluminal placement by endovascular deployment for the treatment of a false lumen associated with a vascular dissection. The stent assembly has a number of self expanding stents
5 connected together to define an elongate substantially cylindrical lumen wall engaging surface. The stents are adapted to provide pressure on the wall of the lumen adjacent to and extending away from a rupture. A deployment device for the stent assembly includes a sheath and a retention and release arrangement to retain the proximal end of the stent graft to the deployment
10 device. Release of the stent assembly is by withdrawal of the sheath before release of its proximal end by the use of a trigger wire of the retention and release arrangement.

DEVICE FOR TREATING AORTIC DISSECTIONDescriptionTechnical Field

This invention relates to a device for the treatment of aortic arch
5 disease and more particularly to the treatment of a form of aortic aneurysm
known as an aortic dissection.

Background of the Invention

An aortic dissection is a form of aneurysm to the descending aorta in
which the wall of the aorta is damaged to such an extent that blood under
10 pressure can get between inner and outer layers of the wall of the aorta to
expand part of the wall into an inflated sac of blood which is referred to as a
false lumen. The inflated sac of blood or false lumen so formed may extend
some distance down the descending aorta and open out into the aorta again
further down.

15 WO 2004/049978 discloses a device for treating aortic dissection with
a self-expanding stent assembly defining an elongate lumen wall engaging
surface. A proximal end of the stent assembly is initially retained by a trigger
wire mechanism to a central catheter.

The present invention seeks to provide a device for treating aortic
20 dissection. A method of treatment for an aortic dissection using the device
will also be discussed.

Throughout this specification the term proximal with respect to both
human or animal vasculature and the deployment device and prosthesis will
be used to refer to the region closest to the heart or that part of the
25 deployment device or of the prosthesis which when in use is closest to the
heart and the term distal will be used for regions of the human or animal
vasculature further from the heart and those parts of the deployment device or
prosthesis which in use are further from the heart.

Summary of the Invention

According to the present invention, there is provided a deployment device and stent assembly for treatment of an aortic dissection, the stent assembly comprising at least one self expanding zig zag stent defining an elongate substantially cylindrical lumen wall engaging surface, and the deployment device comprising an elongate catheter adapted to be deployed over a guide wire, a nose cone at the proximal end of the elongate catheter, a trigger wire arrangement to retain a proximal end of the stent assembly just distal of the nose cone, a sheath over the elongate catheter adapted to retain the stent assembly in a contracted state around the elongate catheter, a release arrangement at the distal end of the elongate catheter to release the trigger wire arrangement and a grip mounted to the sheath to enable the withdrawal of the sheath, the arrangement being such that, upon endoluminal placement by endovascular deployment, retraction of the grip and sheath and release of the stent assembly, the stent assembly expands to provide pressure on the wall of the lumen to close off a false lumen in the lumen wall, characterised in that the trigger wire arrangement comprises a plurality of trigger wires extending through respective apertures in a tubular member surrounding the deployment catheter, the trigger wires engaging with the proximal end of the stent assembly, and then passing back into said apertures.

The stents of the stent assembly are connected by links which are preferably flexible links. They can be provided by metal rings or can be a thread or fibre such as a braided suture thread knotted to or threaded around bends of the zig-zag stents. In the case of a braided suture material the material may be a 5.0 braided suture.

The stents can be formed from stainless steel or Nitinol.

The stent assembly can be in the form of a self expanding spiral stent of zig-zag configuration.

The stent assembly may be provided in three lengths of 4, 6 or 8 stents long, nominally 88, 132 and 178 mm long and have a nominal maximum diameter of 46 mm.

In a preferred form the stent may be constructed from stainless steel wire having a diameter of 0.010 inches.

Preferably the stent assembly comprises a plurality of self expanding zig zag stents and a link arrangement between adjacent stents so that the stents are linked together to define an elongate substantially cylindrical lumen wall engaging surface, each stent having a plurality of struts and bends between the struts and the link arrangement comprising a biocompatible thread or fibre such as a suture thread and knots which are knotted alternately to a bend of one stent and then a bend of an adjacent stent to provide a link thread of zig-zag configuration, whereby upon endoluminal placement by endovascular deployment the stent assembly is adapted to provide pressure on the wall of the lumen to close off a false lumen in the lumen wall with each stent able to act independently of an adjacent stent.

Preferably the distal end of the stent assembly is retained to the deployment device by a distal trigger wire arrangement and there are means at the distal end of the elongate catheter to release the distal trigger wire arrangement.

There can be three trigger wires extending from the release mechanism through the deployment catheter and each of the trigger wires engaging with a proportion of the bends of the proximal most stent of the stent assembly.

The engagement of each trigger wire with the proximal end of the stent assembly can comprise loops of a biocompatible thread engaging between bends of the proximal stent of the stent assembly and the trigger wire.

The proximal end of the stent assembly can comprise a proximal stent and a circumferential biocompatible thread including portions between adjacent bends of the proximal end of the proximal stent and the engagement of each trigger wire with the stent assembly comprises the thread portions
5 between adjacent bends extending around the trigger wire.

The elongate catheter can include means to supply an angiographic contrast medium at a distal end thereof through the catheter.

Links between adjacent stents of the stent assembly can be provided by a thread or fibre such as a suture thread which is knotted alternately to a
10 bend of one stent and then a bend of an adjacent stent to provide a link thread of zig-zag configuration.

The stent assembly can be deployed by:

- a) loading the stent assembly onto a deployment device,
- b) endovascularly deploying the deployment device with the stent
15 assembly loaded thereon to the site of the false lumen,
- c) withdrawing the sheath to expose the stent assembly such that it provides pressure against the wall of the lumen,
- d) releasing the proximal end of the prosthesis by means of releasing the trigger wire arrangement, and
20 e) withdrawing the deployment device.

Preferably the distal end of the stent assembly is retained to the deployment device and previous or subsequent to the step of releasing the proximal end of the prosthesis the distal end is released.

The stent assembly may be deployed in a two stage process to close
25 off a rupture associated with the aortic dissection and to apply pressure to a false lumen associated with the aortic dissection, as follows:

- a) endovascularly deploying a first deployment device with a stent graft retained thereon to the site of the aortic dissection,
- b) checking by radiographic techniques that the stent graft is
30 positioned over the site of the rupture,

- 5 -

- c) deploying the stent graft from the first deployment device,
- d) withdrawing the first deployment device,
- e) endovascularly deploying a second deployment device with a stent assembly loaded thereon to the site of the false lumen,
- 5 f) withdrawing the sheath to expose the stent assembly such that it provides pressure against the wall of the lumen,
- g) releasing the proximal end of the prosthesis by means of releasing the trigger wire arrangement, and
- h) withdrawing the second deployment device.

10 Preferably the distal end of the stent assembly is also retained to the deployment device and previous or subsequent to the step of releasing the proximal end of the prosthesis the distal end is released.

This then generally describes the invention but to assist with understanding reference will now be made to the drawings which show
15 preferred embodiments of the invention.

In the drawings:

Figure 1 shows a schematic view of an aorta with an aortic dissection;

Figure 2 shows the aorta shown in Figure 1 with a first deployment device inserted therein;

20 Figure 3 shows the first stage of deployment of a covered stent graft prosthesis;

Figure 4 shows the fully deployed covered stent graft prosthesis and the deployment of a second deployment device;

25 Figure 5 shows the first state of the deployment of a stent assembly from the second deployment device;

Figure 6 shows the next stage of the deployment of the stent assembly from the second deployment device;

Figure 7 shows the fully deployed stent assembly;

Figure 8 shows a stent assembly of one embodiment of this invention;

Figure 9 shows an alternative stent assembly;

Figure 10 shows a still further stent assembly;

5 Figure 11 shows a still further stent assembly;

Figure 12 shows a detailed view of the proximal end of a deployment device with a stent assembly mounted thereon according to one embodiment of the invention;

10 Figure 13 shows a detailed cross sectional view of the proximal end of the deployment device and stent assembly of Figure 12;

Figure 14 shows a detailed view of part of the proximal end of a deployment device and an alternative method by which a stent assembly may be retained onto the deployment device according to one embodiment of the invention;

15 Figure 15 shows the embodiment of Figure 14 when retention sutures are pulled tight;

- 7 -

Figure 16 shows a detailed view of part of the proximal end of a deployment device and an alternative method by which a stent assembly may be retained onto the deployment device according to the invention; and

5 Figure 17 shows the embodiment of Figure 16 when the trigger wires are pulled into place.

Detailed Description

Looking more closely to the drawings and in particular Figure 1 it will be seen that the aorta comprises an ascending aorta 1 which receives blood from the heart through an aortic valve 2. At the upper end of the ascending aorta there are
10 branches for the innominate artery 3 the left common carotid artery 4 and the subclavian artery 5. The aorta after these is referred to as the descending aorta 6 and it is in this region that an aortic dissection can occur. In an aortic dissection the wall of the descending aorta can be injured such as by a traumatic injury so that a partial rupture or tear 7 occurs and the wall of the descending aorta splits so that
15 there is an outer wall 8 and an inner wall 9 between which a false lumen 10 occurs. At some distance down the false lumen 10 the false lumen may again open out into the aorta 6 such as at 11. The dotted line 12 shows the normal position of the wall of the aorta.

Treatment of the aortic dissection requires that the rupture 7 be closed
20 off and the false lumen 10 deflated.

As can be seen in Figure 2, a first deployment device 15 with a nose cone 16 has been advanced over a guide wire 17 through the true lumen 18 of the descending aorta 6. Preferably the deployment device is inserted through a femoral artery and up through the iliac arteries into the aorta using a technique
25 known as the Seldinger technique.

Once the deployment device is in substantially the correct place angiographic fluids may be supplied through a hollow elongate catheter 20 in the deployment device to exit through the nose cone 16 so that with the use of angiographic contrast medium the region can be visualised by radiographic
30 techniques.

- 8 -

When the deployment device is found to be in the correct position, the sheath 24 of the deployment device is withdrawn to the position as shown in Figure 3 at which stage the stent graft 25 is expanded except that the proximal end 27 is retained by a trigger wire retention mechanism to the central catheter 20. At this stage the pressure of blood flow from the heart will still tend to cause blood flow around the stent graft 25.

Next a trigger wire release mechanism is released so that the proximal end 27 of the prosthesis 25 is allowed to open as shown in Figure 4 and the barbs 30 on the proximal end of 27 of the stent graft 25 engage against the wall of the aorta to securely fix the stent graft 25 in the upper end of the descending aorta with the stent graft 25 covering the rupture 7 and essentially closing it off so that blood can no longer flow into the false lumen 10. Blood can then flow through the stent graft and exit out at the distal end 29 of the stent graft 25.

Next, the first deployment device can be withdrawn and a second deployment device 40 deployed over the guide wire 17. Alternatively the first deployment device 15 can be withdrawn leaving the sheath 24 and guide wire 17 in place and a second deployment device 40 can be deployed through the sheath 24 and over the guide wire 17.

The second deployment device 40 has a elongate deployment catheter 44 and a nose cone 46 and carries a stent assembly 42 as will be discussed in relation to Figures 8 to 11 and the stent assembly 42 is mounted onto the second deployment device 40 by various arrangements as will be discussed in relation to Figures 12 to 17.

When the second deployment device is in place as shown in Figure 4 the sheath 48 of the second deployment device 40 is withdrawn as shown in Figure 5 and 6 so that the stent assembly 42 is exposed and gradually released until it is fully released except where it is retained by a release mechanism 50 just distal of the nose cone 46 as will be discussed in relation to Figures 12 to 17. There is optionally also a distal retention arrangement 47 at the distal end of the stent assembly. The distal retention arrangement 47 can be released either before or after release of the proximal retention arrangement 50. The self expanding stents

- 9 -

of the stent assembly 42 are allowed to engage against the wall of the true lumen 18 and provide pressure onto the wall particularly where the false lumen occurs to gradually deflate and close off the false lumen as shown in Figure 6.

5 If the stent assembly 42 was not retained at its proximal end just distal of the nose cone 46 then there is a danger that, as the sheath 48 was withdrawn or the stent assembly pushed out of the sheath 48, its proximal end could fan out and actually turn inside out or at least jamb in an unacceptable position in the descending aorta. This could put unacceptable pressure on the wall of the aorta which could be torn or ruptured.

10 The distal retention arrangement 47 is particularly useful to prevent a too rapid release of the distal end of the stent assembly.

The release mechanism 50 can then be released and then the entire second deployment device can be withdrawn to leave the stent assembly 42 in place in the descending aorta 6 as shown in Figure 7.

15 Figure 7 shows the stent assembly 42 placed distally of the covered stent graft 25 but in an alternative arrangement the stent assembly 42 could be placed so that its proximal end 37 is within the distal end of the stent graft 25.

Figure 8 shows a first embodiment of a stent assembly 42 for use with the method of the present invention. The stent assembly 42 has a plurality of zig
20 zag self expanding Gianturco type zig zag stents 35 and each apex 36 of the stents is linked to the next stent up or down by flexible links 37. The flexible links may be wire rings or loops of thread or fibre such as a suture thread. The flexible links enable each stent of the stent assembly to expand separately as the false lumen is deflated which may occur over a period of several days or weeks. The stents
25 provide gradual pressure on the wall of the lumen to close the false lumen and open up the true lumen.

It will be realised that different numbers of stents may be used depending upon the nature of the aortic dissection and the length of aorta to be opened and the dimensions of the rupture in the wall of the aorta.

30 Figures 9 and 10 show further embodiments of stent assemblies 59 and 61 respectively according to the present invention. In these embodiments bends 60

- 10 -

between the struts 62 of the zig zag self expanding stents 64 are linked by means of a fibre or thread 68 such as a suture thread with the thread knotted to each bend 60 by a knot 66 so that each self expanding stent can act independently of its neighbours. It will be noted that the thread or fibre is knotted alternately to a bend of one stent and then a bend of an adjacent stent to provide a link thread of zig zag configuration.

The stent assembly 59 in Figure 9 can have up to eight stents with a total length of from 178 mm and a diameter when expanded of 46 mm. The stent assembly 61 in Figure 10 has four stents with a total length of 88 mm and a diameter when expanded of 46 mm. A further embodiment may have a length of 132 mm with six stents. In one embodiment the stents may be formed from 0.016 inch diameter stainless steel wire but in other embodiments there may be differing wire thicknesses to vary the radial force applied to the vessel wall.

Figure 11 shows a still further embodiment of the stent assembly of the invention. In this embodiment the stent assembly 70 is formed from a continuous spiral of zig-zag stent 72 with again loops in adjacent spirals joined by a thread 74 such as a suture thread. Again suitable knots may be used to assist with the controlled linking of adjacent portions of the spiral stent.

In an alternative embodiment of the invention of a stent assembly according to the invention the stents and the links between the stents may be in the form of a mesh and formed from a biocompatible and biodegradable mesh material so that after it has performed its work of providing a radial pressure onto the wall of the aorta it can biodegrade in the bloodstream.

Figure 12 shows a detailed view of the proximal end of a deployment device with a stent assembly mounted thereon according to one embodiment of the invention and Figure 13 shows a detailed cross sectional view of the embodiment shown in Figure 12.

The deployment device 40 has a deployment catheter 44 extending to a nose cone 46 at its proximal end. Just distal of the nose cone 46 a mounting and release mechanism 50 is provided to retain the proximal end 43 of the stent assembly 42. The stent assembly 42 is held in a contracted condition by a sheath

45. The mounting and release mechanism 50 has a catheter 53 around the deployment catheter 44 with at least one internal lumen 52 through which pass trigger wires 54. A respective aperture 56 opening into the lumen 52 allows a bight 58 of each trigger wire to be exposed. Lengths of thread 59 such as a suture thread are used to fasten each of the apices 51 of the proximal-most stent of the stent assembly 42 separately to the bights 58 of the trigger wires 54. When the stent assembly is to be finally released the trigger wires 54 are withdrawn and each of the threads 59 are released from the bights 58 so that the proximal end of the stent assembly can open against the vessel wall as discussed with reference to Figure 6. The loops or lengths of thread 59 remain fastened to the apices of the proximal-most stent of the stent assembly.

Figures 14 and 15 show a detailed view of part of the proximal end of a deployment device and an alternative method by which a stent assembly may be retained onto the deployment device. Figure 15 shows the embodiment of Figure 14 when the retaining sutures are pulled tight.

In Figure 14 the deployment device 70 has a deployment catheter 72 extending to a nose cone 74 at its proximal end. Just distal of the nose cone 74 a mounting and release mechanism 76 is provided to retain the proximal stent 78 of the stent assembly 80. The mounting and release mechanism 76 comprises an enlarged end 82 of a trigger wire sleeve 84 and three trigger wires 86 which loop out of apertures 88 in the enlarged end 82 of a trigger wire sleeve 84.

One process for the loading of the proximal-most stent 78 of the stent assembly 80 to the deployment device 70 is as follows. In this embodiment the proximal stent 78 of the stent assembly 80 has twelve points or proximal bends.

In a first stage three equally spaced points 90 are mounted to respective trigger wires 86 by passing the respective trigger wire through the point or bend and then pushing the trigger wire back into the aperture 88. This holds these three points to the enlarged end 82 of the trigger wire sleeve 84. A portion of suture thread 92 is then tied with a knot 93 to the next point 94 clockwise from each of the points 90 captured by a trigger wire 86 (clockwise looking from the top – i.e. the proximal end). The suture thread 92 is then threaded clockwise through the next

- 12 -

two points 95, 96 passing them from the outside inwards. The suture thread 92 is then passed beneath the respective trigger wire 86 and then re-threaded through the points 95, 96 in the same alignment as the initial threading. Then suture thread 92 is then tied to the loose end of the suture thread at the knot 93 at the point 94 and the suture thread is pulled tight and knotted three times. Then loose tails of suture thread are then cut short. When threaded this way, the stent points "stack up" neatly as the suture is tightened and the suture loops are short. If they are threaded in the opposite direction, they do not stack neatly, and the suture loops are longer.

Figure 15 shows the suture threads 92 pulled tight and the points 94, 95 and 96 neatly stacked. The sheath 98 of the deployment device has been moved up to cover most of the stent assembly leaving only part of the proximal stent 78 exposed.

By the arrangement shown in Figures 14 and 15 upon release of the stent assembly the sutures will remain fixed to the points 94 and not cause problem within the blood vessel. Other suturing methods may be devised in which the suture remains with the delivery device.

Figure 14 also shows one method by which the adjacent stents of the stent assembly can be joined for optimal deployment. The proximal stent 78 of the stent assembly 80 has a plurality of struts 100 and bends 102, 104 and 106, for instance, between the struts 100 and the distally adjacent stent 108 has bends 110, 112, 114, and 116, for instance. The link arrangement between the stent 78 and the stent 108 comprises a thread or fibre such as a suture thread 118 which is knotted such as at 120 alternately to a bend 102 of one stent and then a bend 112 of an adjacent stent to provide a link thread of zig zag configuration. Upon endoluminal placement by endovascular deployment the stent assembly 80 is adapted to provided pressure on the wall of the lumen to close off a false lumen in the lumen wall with each stent able to act independently of an adjacent stent.

Figures 16 and 17 show a detailed view of part of the proximal end of a deployment device and an alternative method by which a stent assembly may be

- 13 -

retained onto the deployment device before and during delivery. Figure 17 shows the embodiment of Figure 16 when the proximal trigger wires are pulled into place.

5 In Figure 16 the deployment device 70 has a deployment catheter 72 extending to a nose cone 74 at its proximal end. Just distal of the nose cone 74 a mounting and release mechanism 76 is provided to retain the proximal stent 78 of the stent assembly 80. The mounting and release mechanism 76 comprises an enlarged end 82 of a trigger wire sleeve 84 and trigger wires 86 which loop out of apertures 88 in the enlarged end 82 of a trigger wire sleeve 84.

10 The process for the loading proximal stent 78 of the stent assembly 80 onto the deployment device 70 according to this embodiment of the invention is as follows. In this embodiment the proximal stent 78 of the stent assembly 80 has twelve points or proximal bends 101.

15 For this embodiment the proximal end bends 101 of the proximal stent 78 are joined by a circumferential length of suture thread 102 and knotted 104 to each bend 101 in a similar manner to the joining of adjacent stents lower down the stent assembly 80.

20 To connect the trigger wire 86 to the proximal stent 78 the trigger wire is extended from the aperture 88 and then passed once around the suture 102 between each bend 101 for four portions between bends. This procedure is shown in Figure 16. The end of the trigger wire is then placed back into the aperture 88, extended into the nose cone and pulled tight. This draws the lengths of suture material 102 between each bend 101 up to the aperture 88 to give the configuration shown in Figure 17. This operation is repeated for the two other trigger wires 86.

25 By the arrangement shown in Figures 16 and 17 upon release of the stent assembly the suture thread 102 will remain fixed to the bends 101 and not cause problem within the blood vessel.

30 Throughout this specification various indications have been given as to the scope of the invention but the invention is not limited to any one of these but may reside in two or more of these combined together. The examples are given for illustration only and not for limitation.

Claims

1. A deployment device and stent assembly for treatment of an aortic dissection, the stent assembly comprising at least one self expanding zig zag stent defining an elongate substantially cylindrical lumen wall engaging surface, and the deployment device comprising an elongate catheter adapted to be deployed over a guide wire, a nose cone at the proximal end of the elongate catheter, a trigger wire arrangement to retain a proximal end of the stent assembly just distal of the nose cone, a sheath over the elongate catheter adapted to retain the stent assembly in a contracted state around the elongate catheter, a release arrangement at the distal end of the elongate catheter to release the trigger wire arrangement and a grip mounted to the sheath to enable the withdrawal of the sheath, the arrangement being such that, upon endoluminal placement by endovascular deployment, retraction of the grip and sheath and release of the stent assembly, the stent assembly expands to provide pressure on the wall of the lumen to close off a false lumen in the lumen wall, the trigger wire arrangement comprising a plurality of trigger wires extending through respective apertures in a tubular member surrounding the deployment catheter, the trigger wires engaging with the proximal end of the stent assembly, and then passing back into said apertures, the proximal end of the stent assembly comprising a proximal stent with a plurality of proximal bends, and said proximal end being fastened to the trigger wires by thread means, characterized in that every proximal bend is fastened to a trigger wire.

2. The deployment device and stent assembly as in claim 1 wherein said thread means comprises a plurality of threads corresponding in number to the number of proximal bends of the proximal stent, wherein there are n trigger wires and the proximal bends of the proximal stent are arranged into n circumferentially arranged groups of adjacent proximal bends, each trigger wire corresponding to a group, and wherein every proximal bend of each

- 15 -

group is individually connected by a respective one of the threads to the trigger wire corresponding to said thread's group.

3. The deployment device and stent assembly as in claim 1 wherein said thread means comprises one or more threads, and each trigger wire engages
5 with the thread or with a respective one of the threads.

4. The deployment device and stent assembly as in claim 3 wherein there are the same number n of threads as trigger wires, and the proximal bends of the proximal stent are arranged into n circumferentially-arranged groups of adjacent proximal bends, the trigger wires being respectively looped through a
10 first bend of each of the groups of bends, and the threads being respectively engaged with a trigger wire and with the other bends in the same group of bends as the bend looped through by the trigger wire.

5. The deployment device and stent assembly as in claim 3 wherein all of said proximal bends are interconnected by a single circumferential thread.

15 6. The deployment device and stent assembly as in any one of claims 1 to 5 wherein the stent assembly comprises a plurality of self expanding zig zag stents with links between adjacent stents so that the stents are linked together to define the elongate substantially cylindrical lumen wall engaging surface.

20 7. The deployment device and stent assembly as in claim 6 wherein the links comprise at least one of a thread or fibre knotted to or threaded through bends of the zig zag stents.

8. The deployment device and stent assembly as in claim 7 wherein the thread or fibre is knotted alternately to a bend of one stent and then a bend of
25 an adjacent stent to provide a link thread of zig-zag configuration.

- 16 -

9. The deployment device and stent assembly as in claim 6 wherein the stents are formed from a material selected from stainless steel or Nitinol.

10. The deployment device and stent assembly as in any one of claims 1 to 5 wherein the stent assembly comprises a plurality of self
5 expanding zig zag stents and a link arrangement between adjacent stents so that the stents are linked together to define an elongate substantially cylindrical lumen wall engaging surface, each stent having a plurality of struts and bends between the struts and the link arrangement comprising at least one of a biocompatible thread or fibre such as a suture thread and knots
10 which are knotted alternately to a bend of one stent and then a bend of an adjacent stent to provide a link thread of zig-zag configuration, the arrangement being such that upon endoluminal placement by endovascular deployment, the stent assembly is adapted to provide pressure on the wall of the lumen to close off a false lumen in the lumen wall with each stent able to
15 act independently of an adjacent stent.

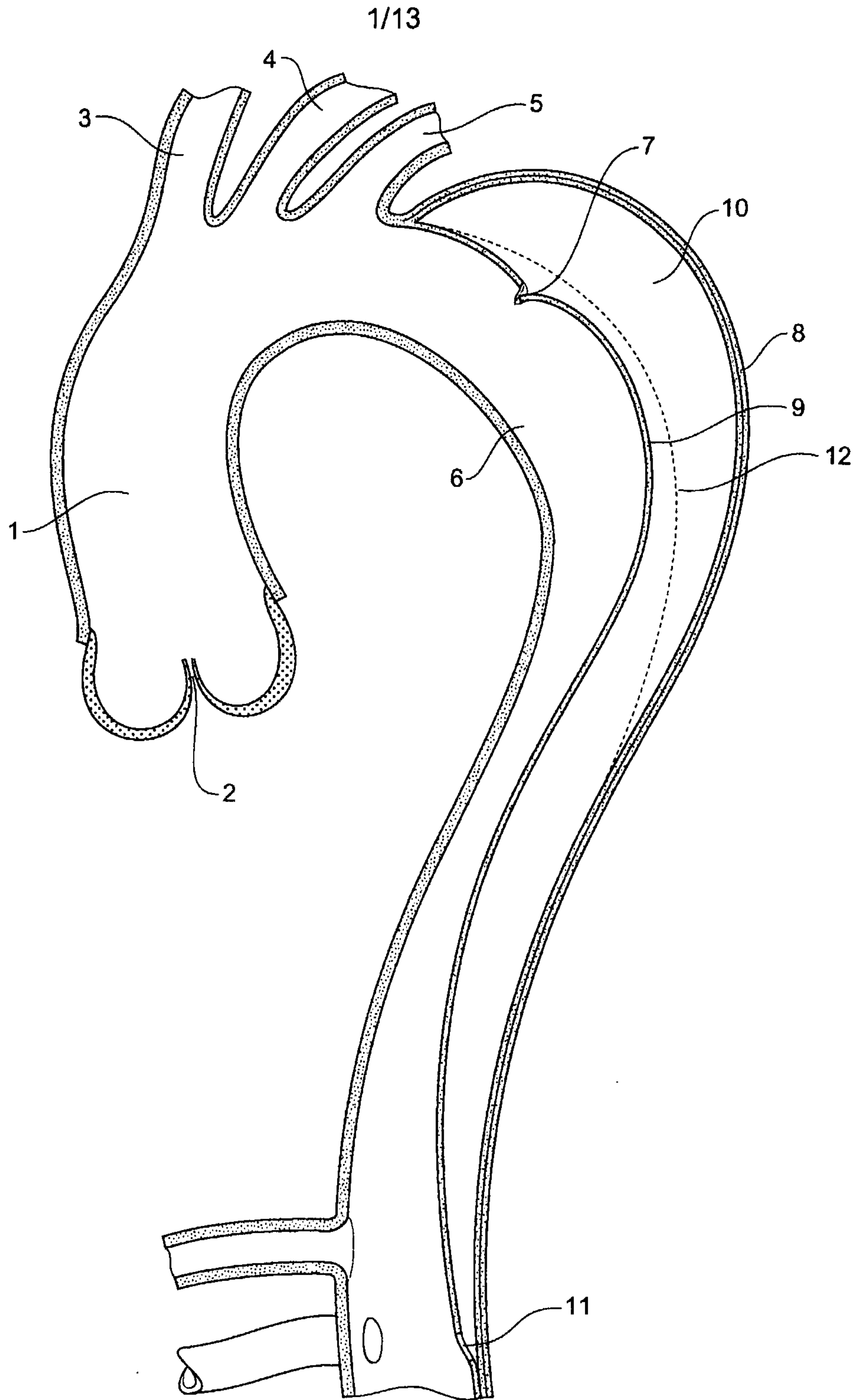

Fig 1

2/13

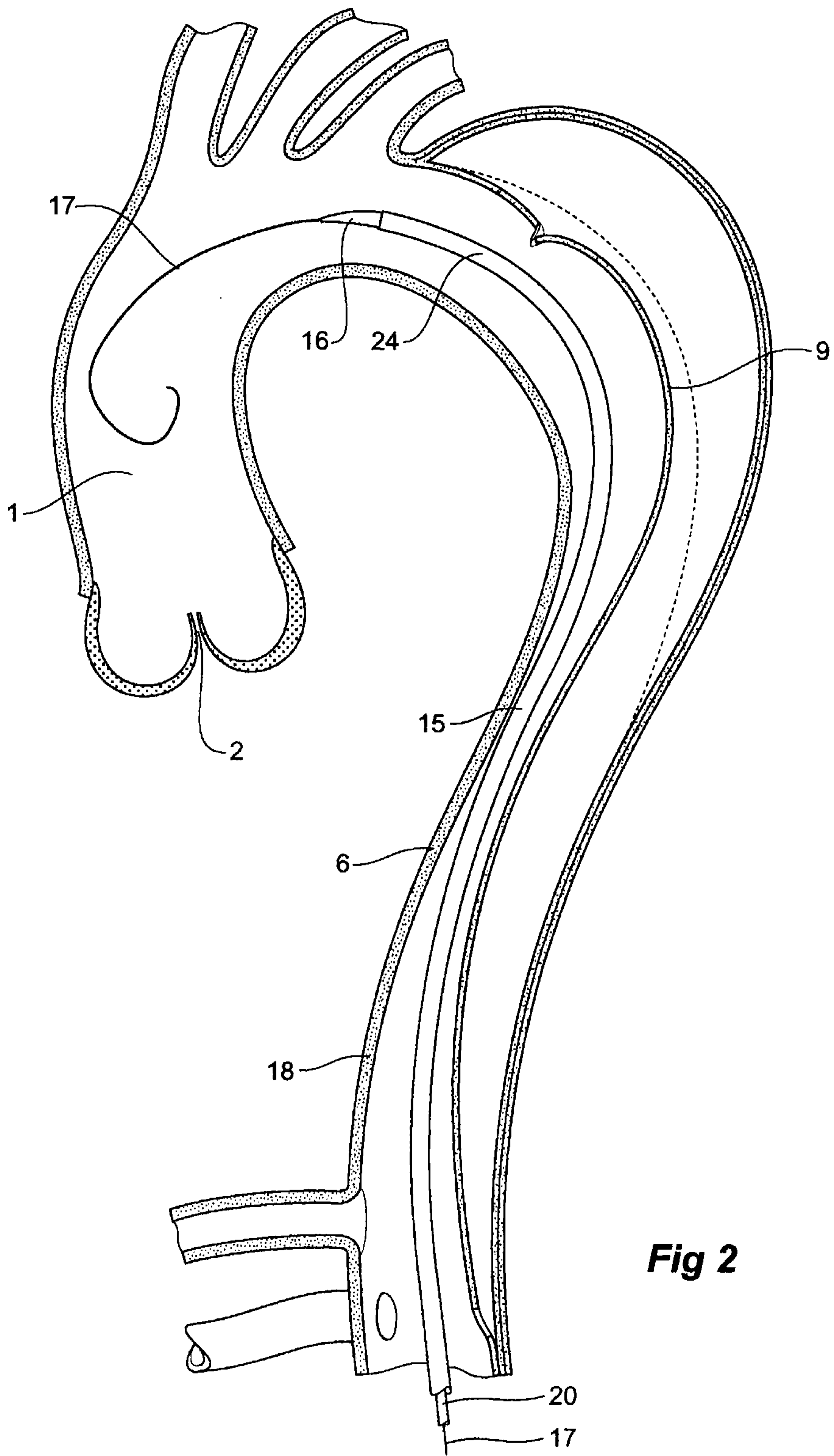

Fig 2

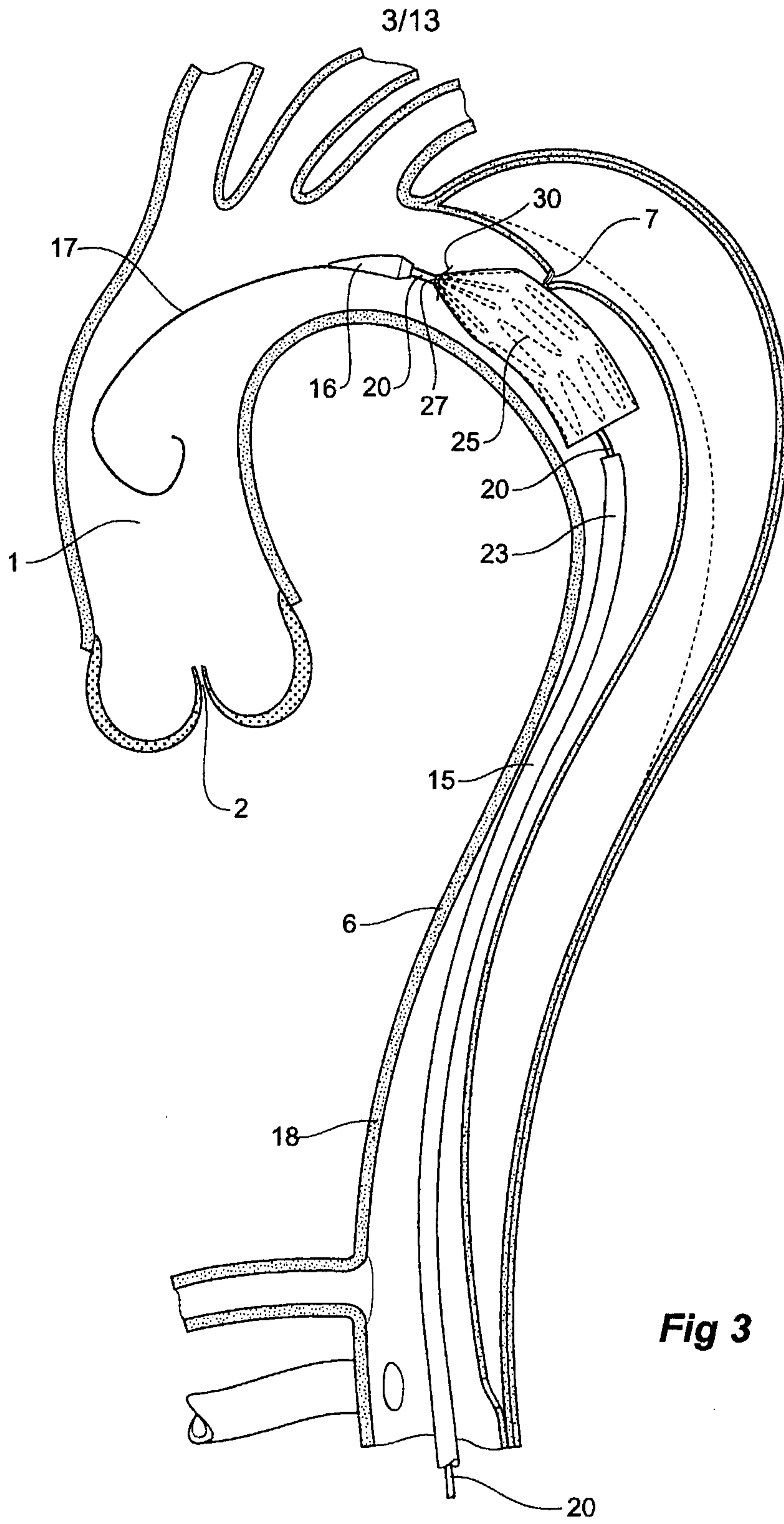
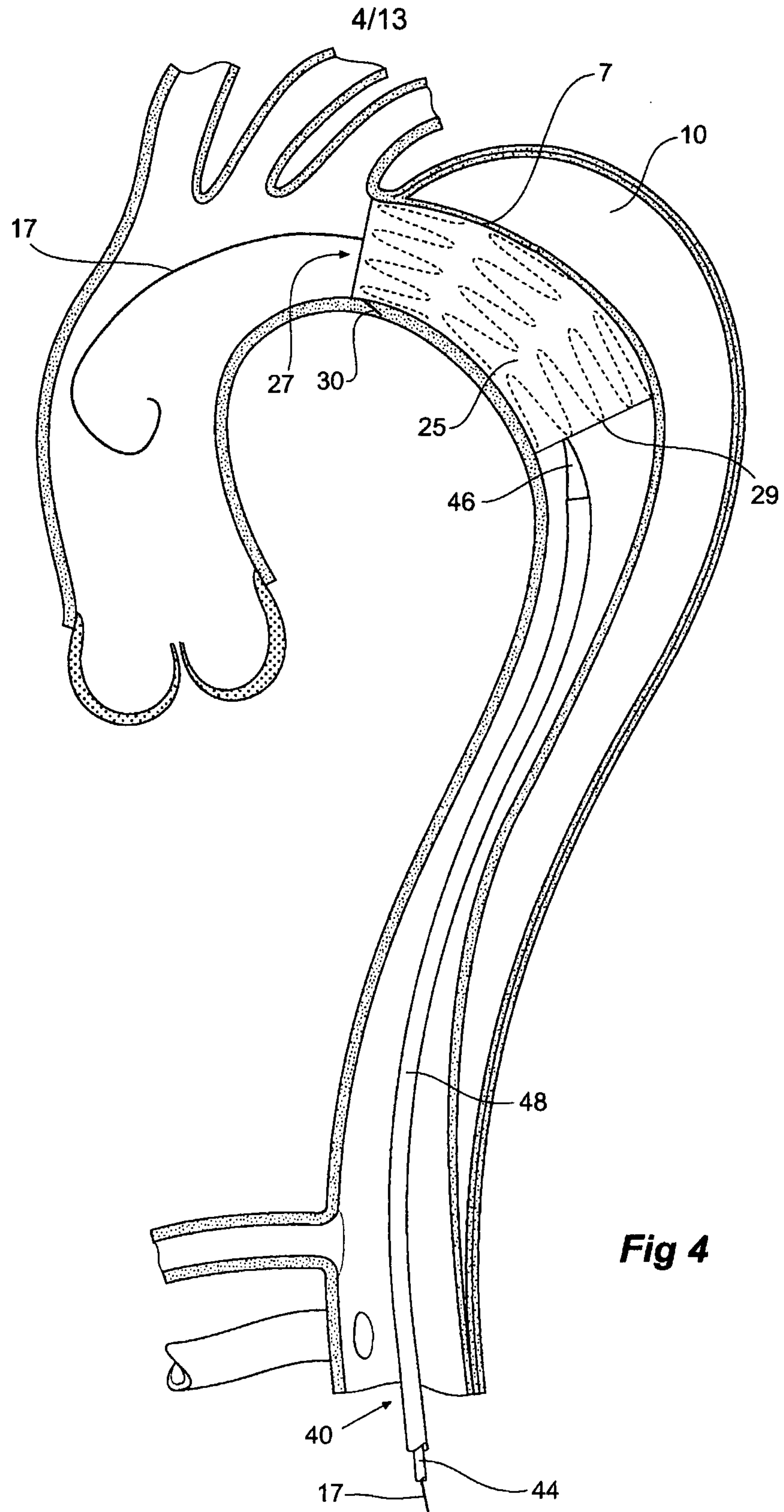
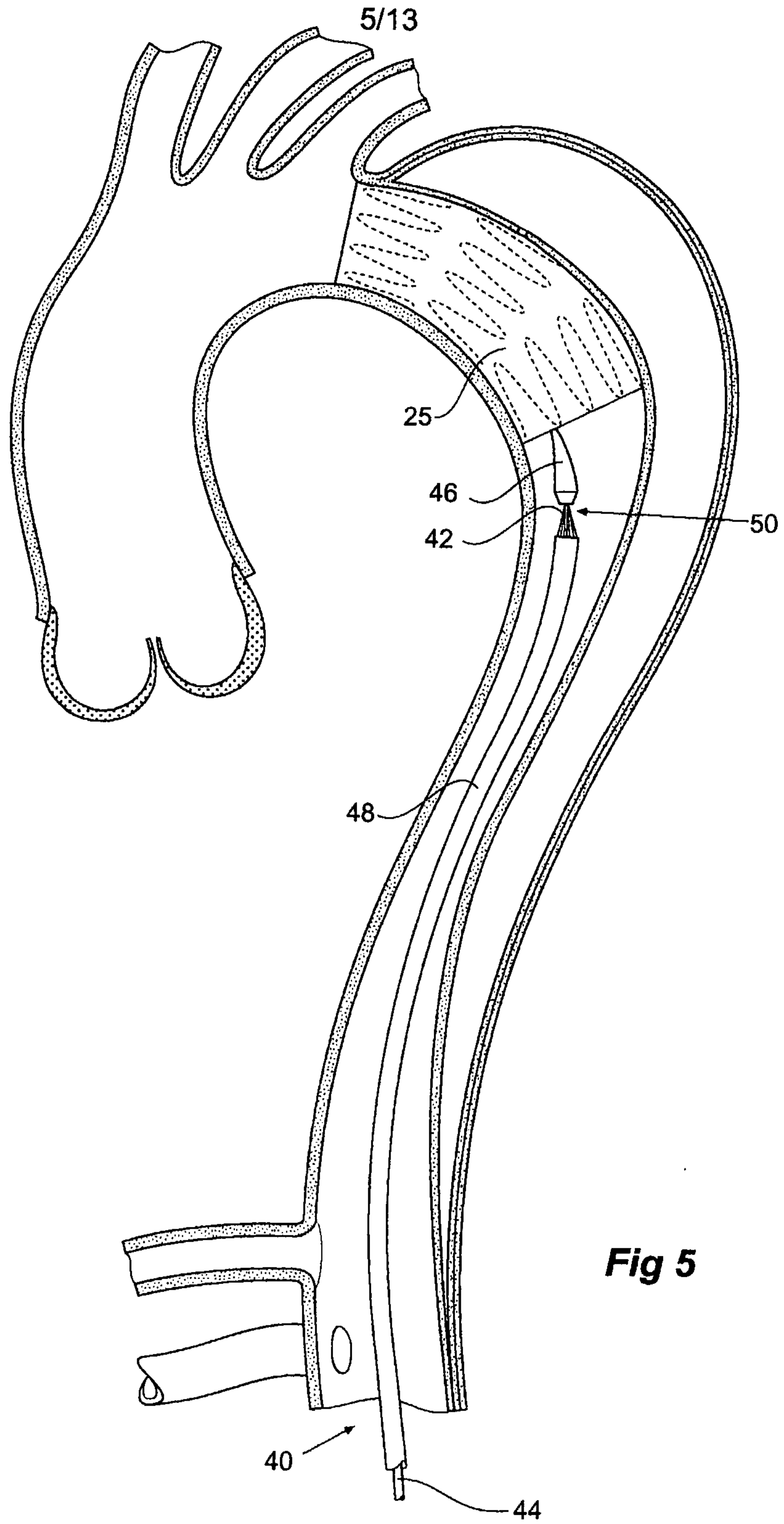
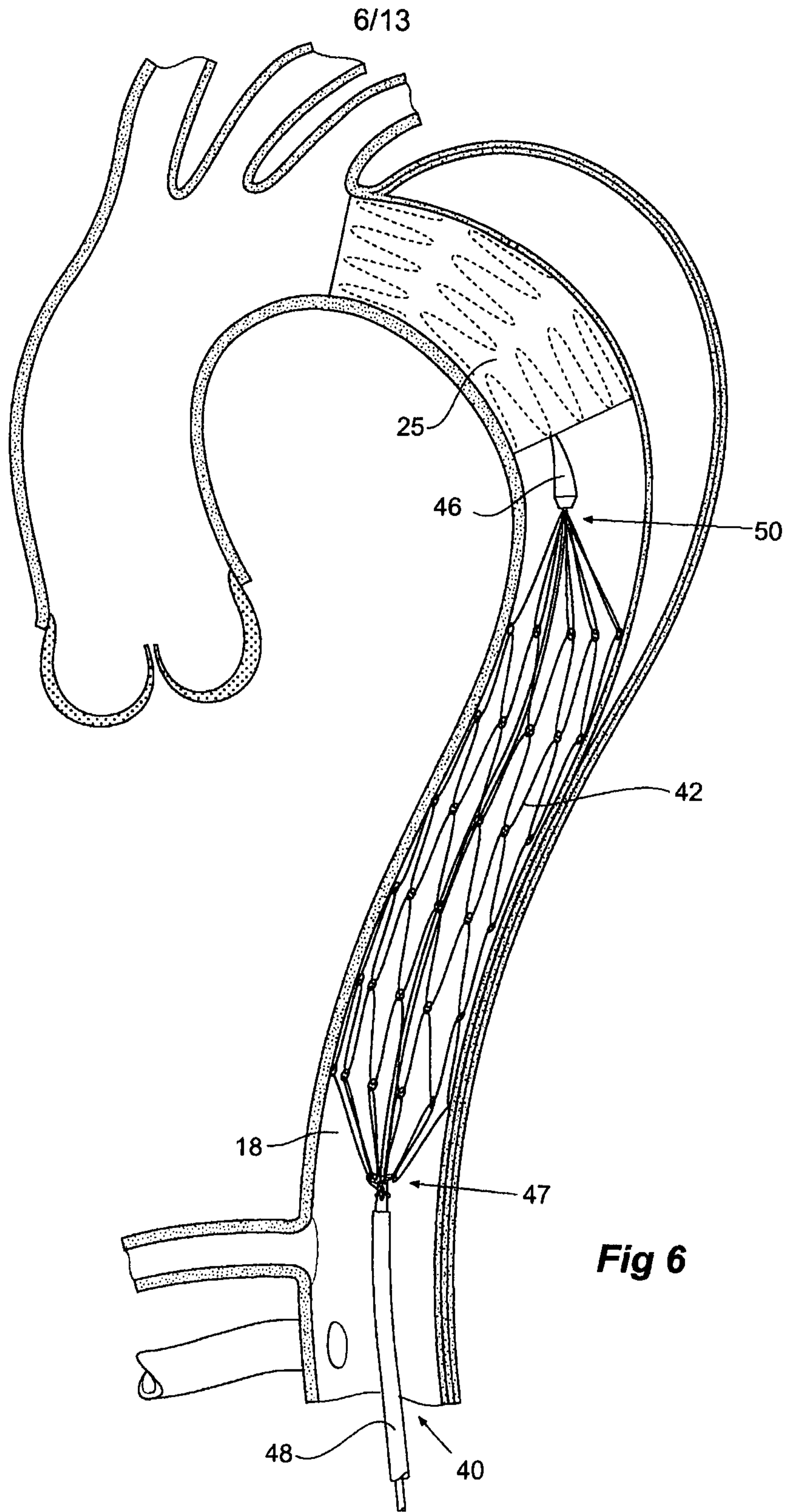
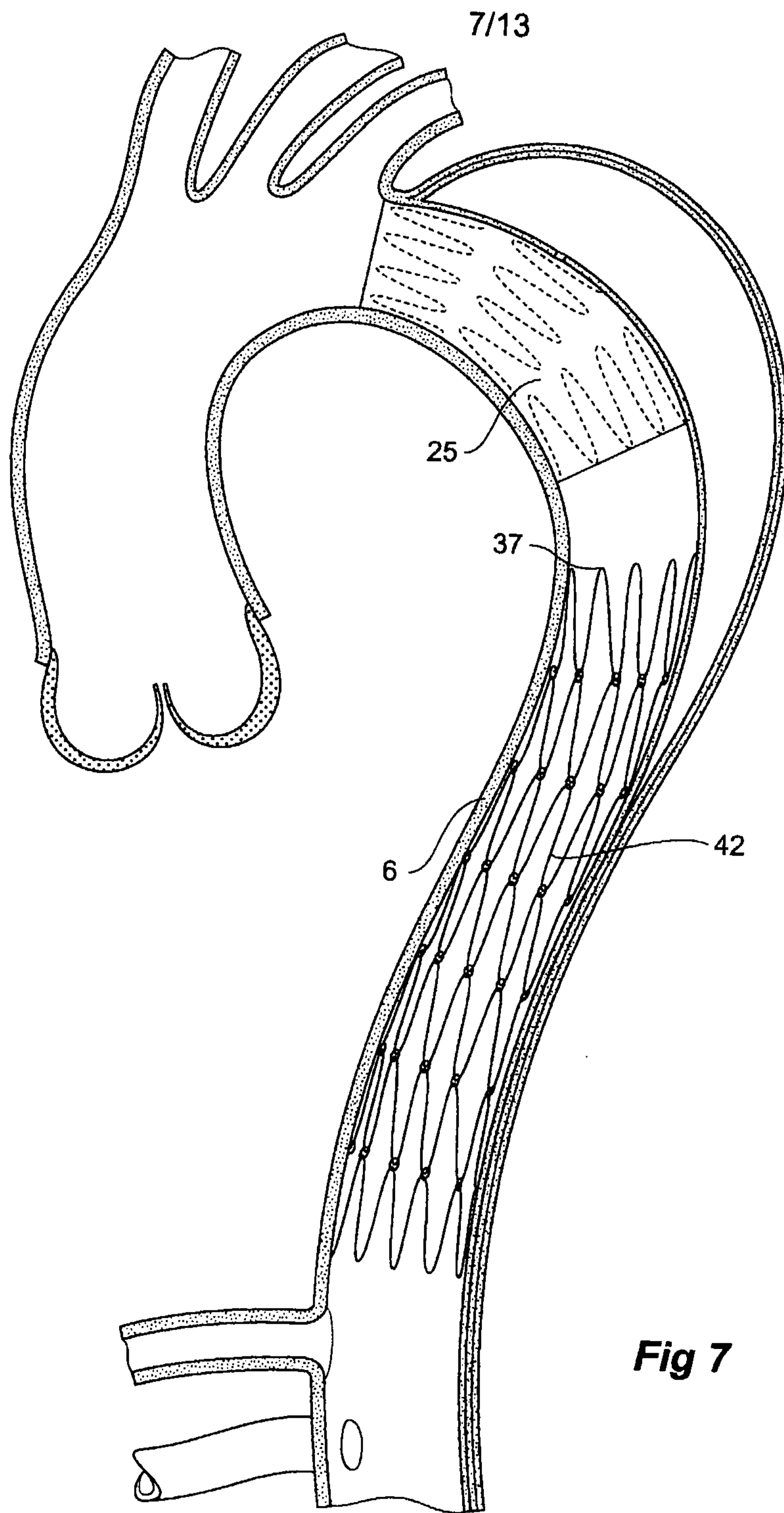

Fig 3









8/13

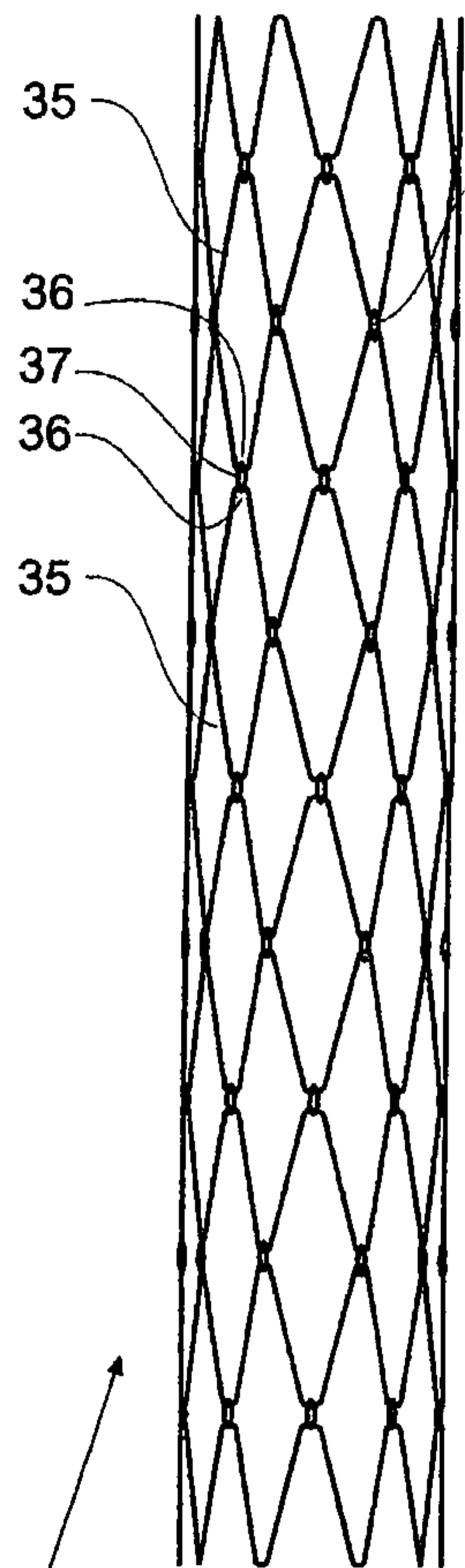

Fig 8

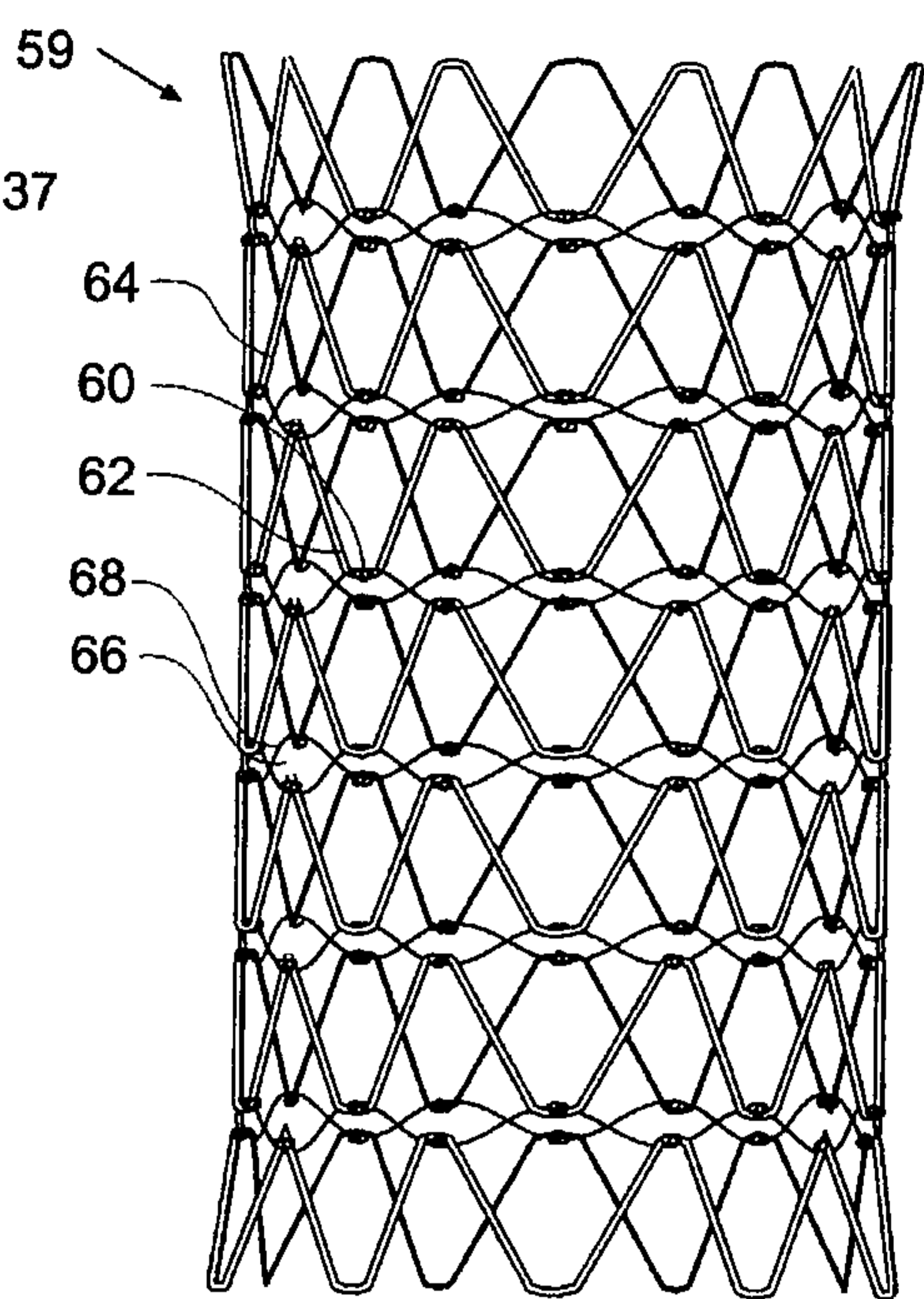

Fig 9

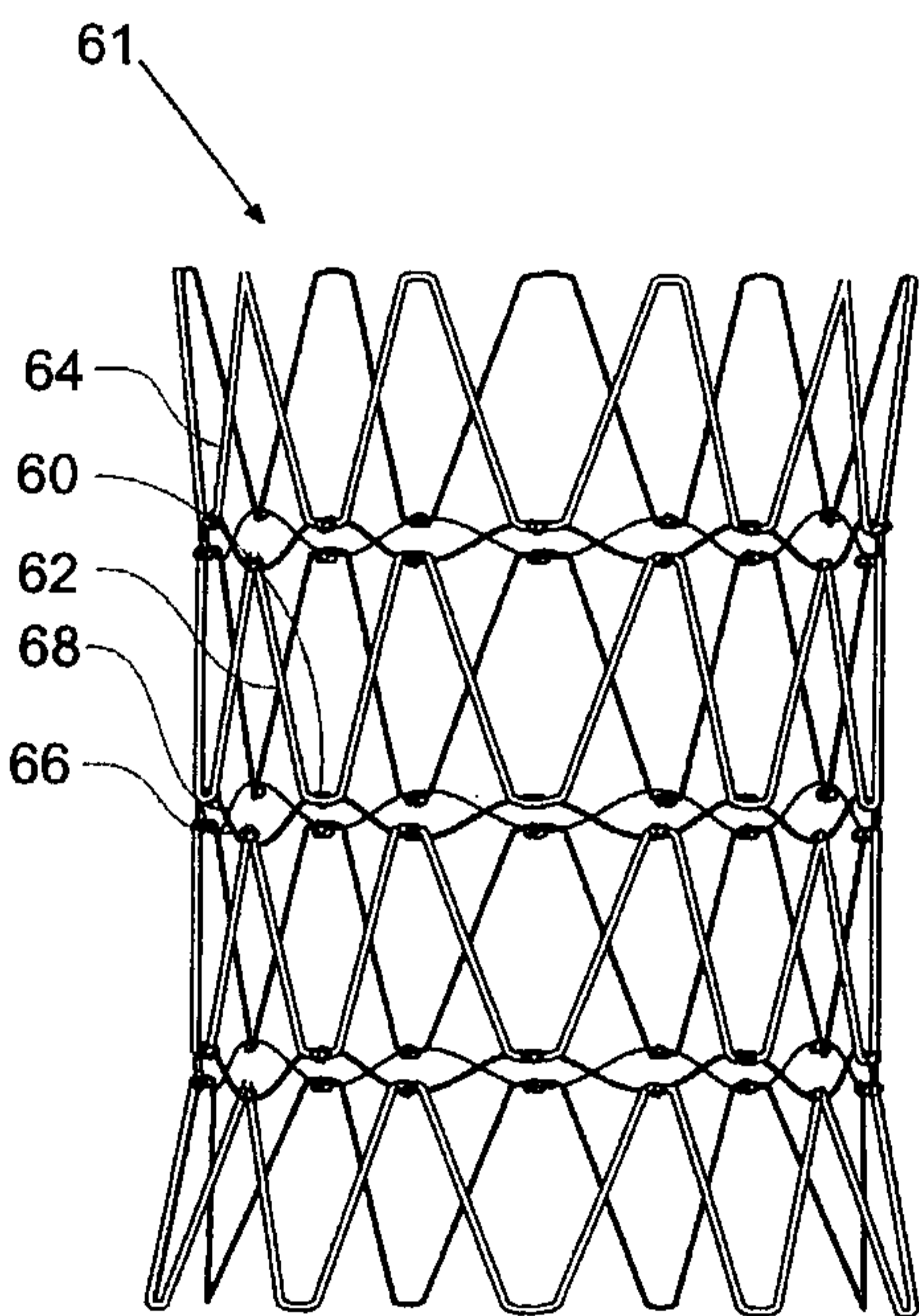

Fig 10

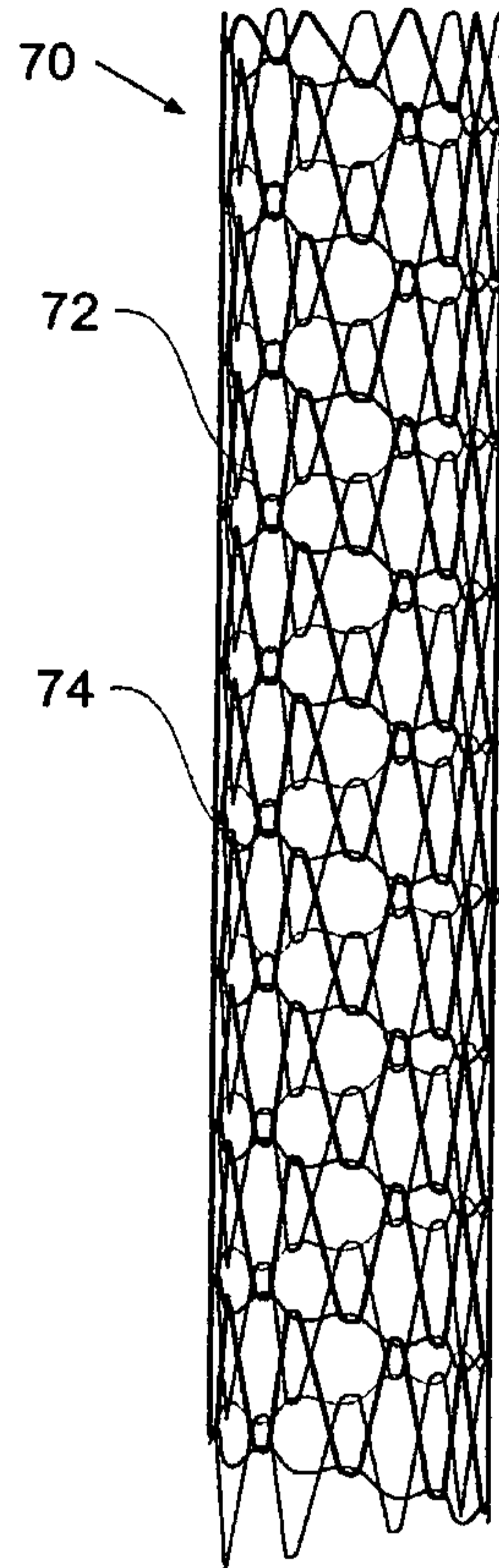
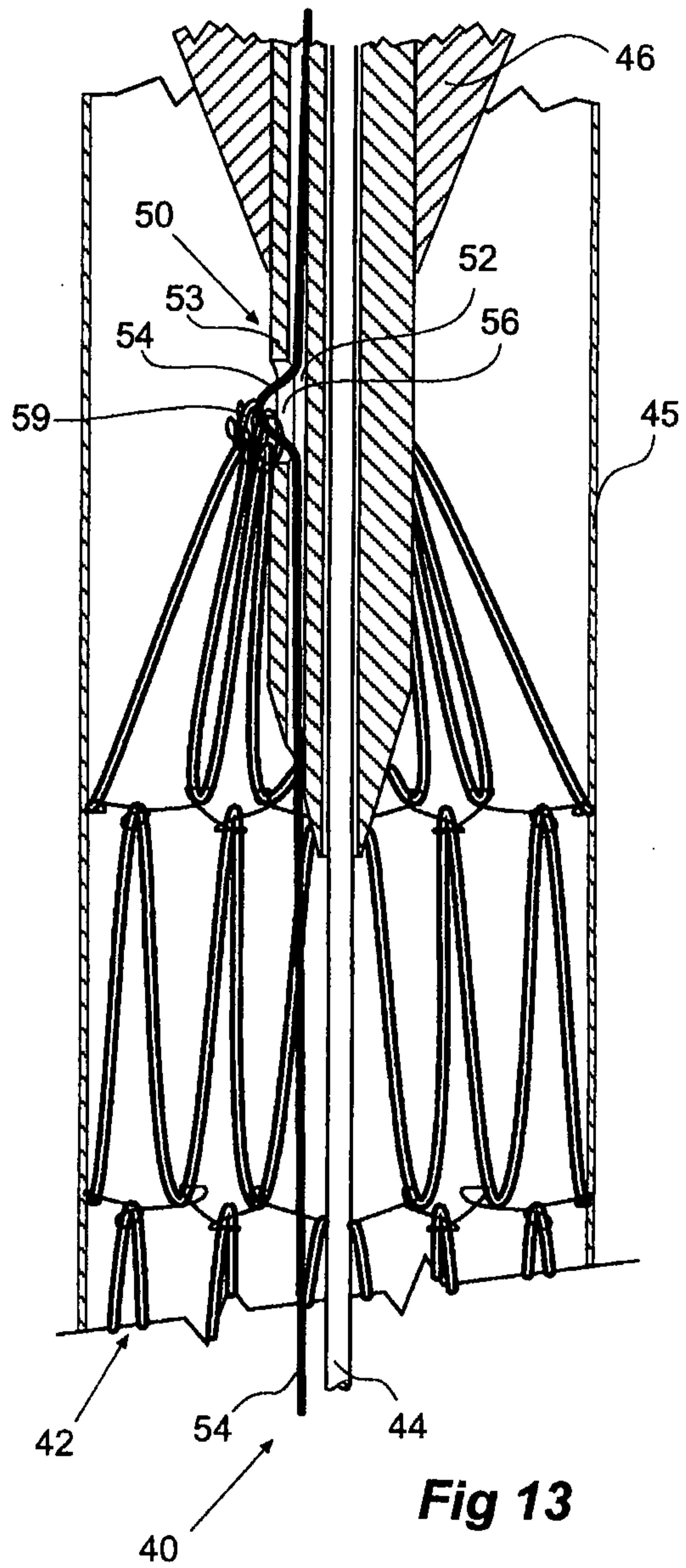
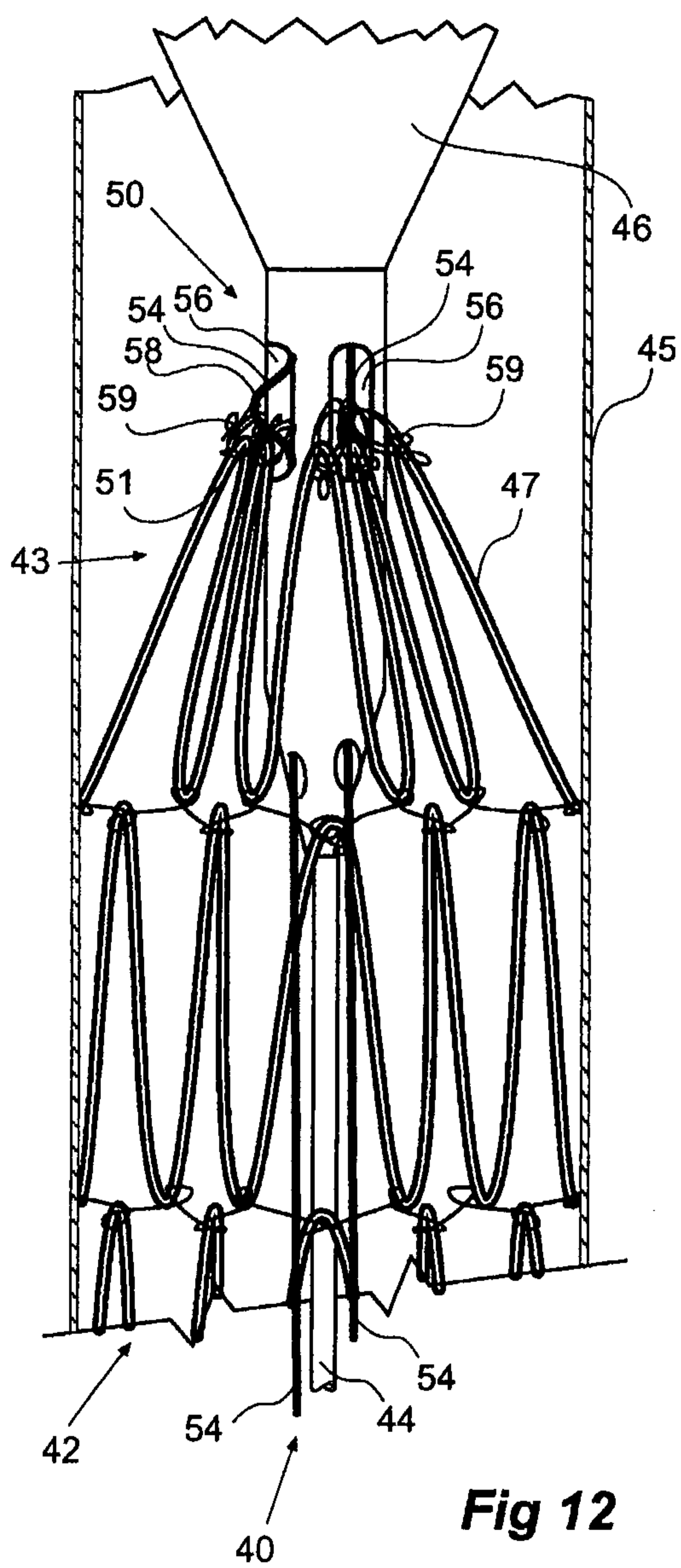

Fig 11



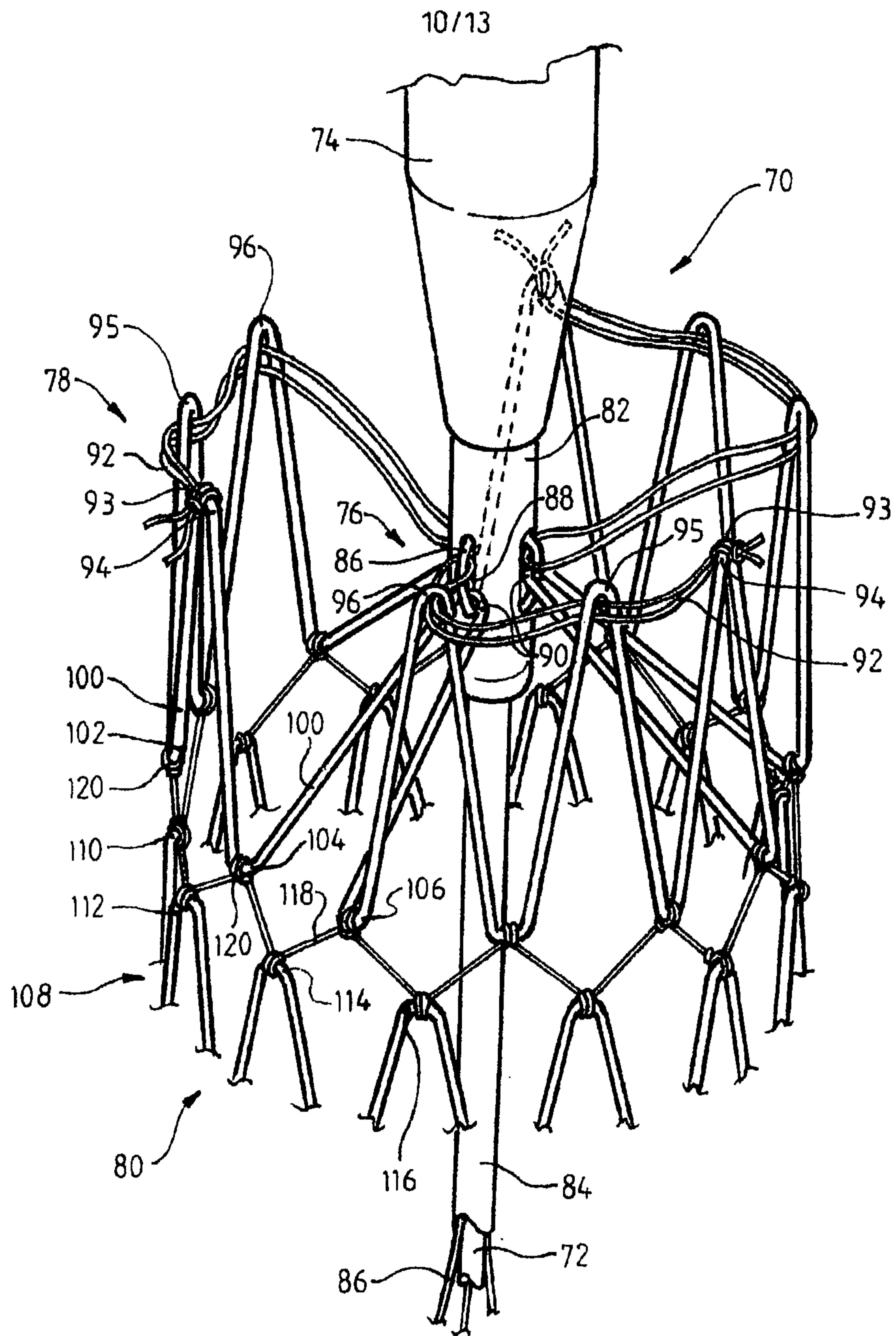

Fig 14

11/13

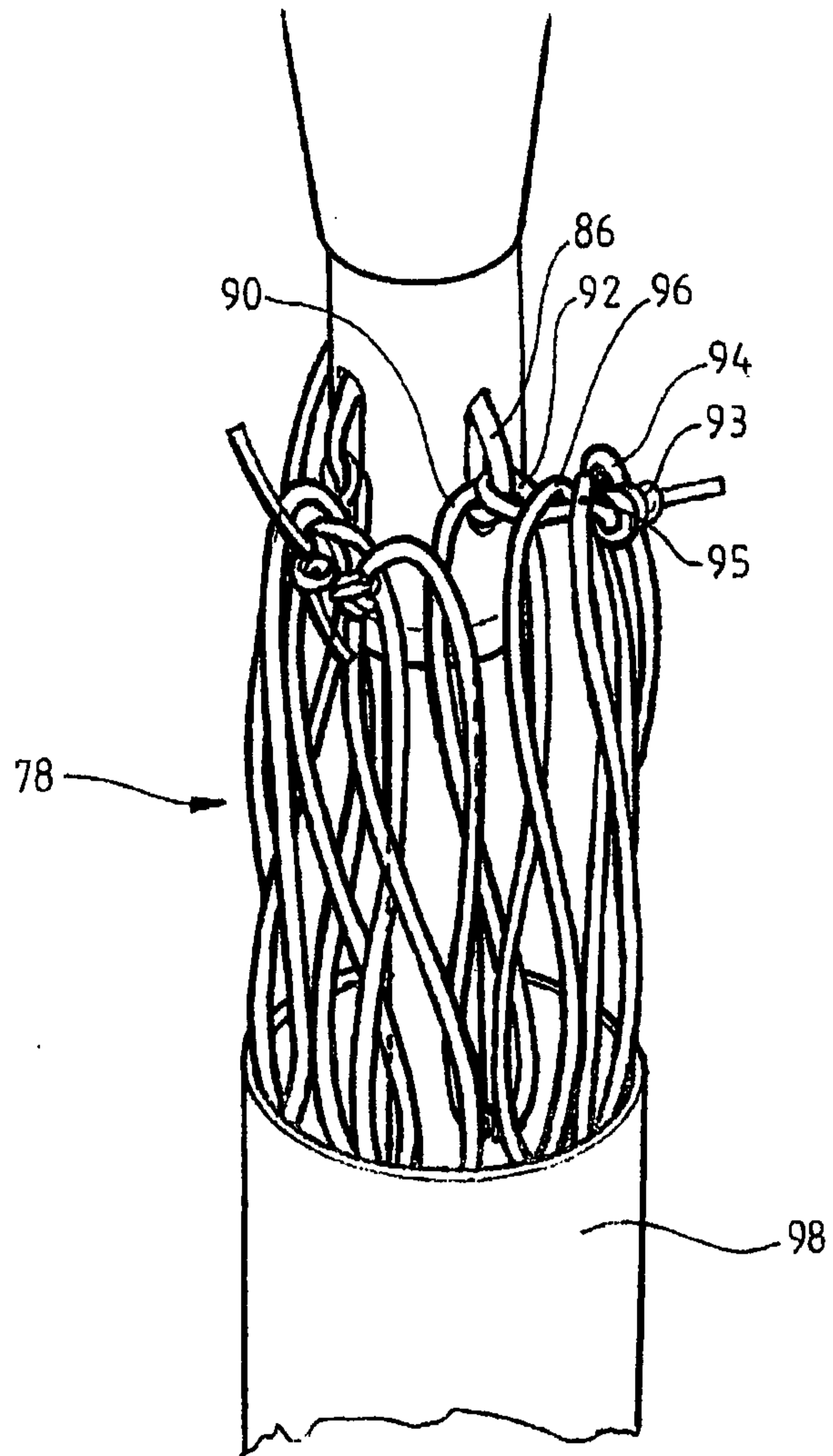

Fig 15

12/13

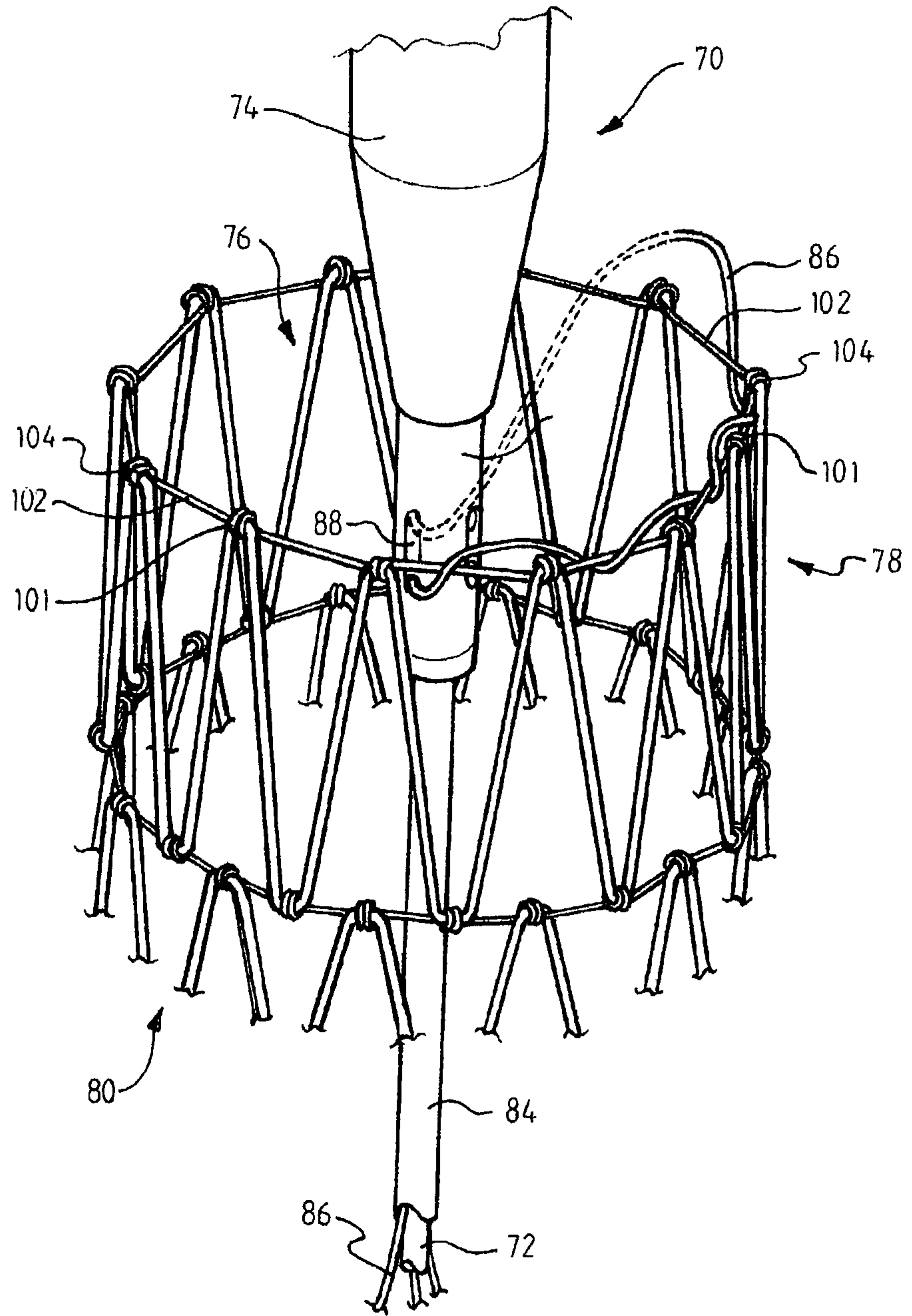

Fig 16

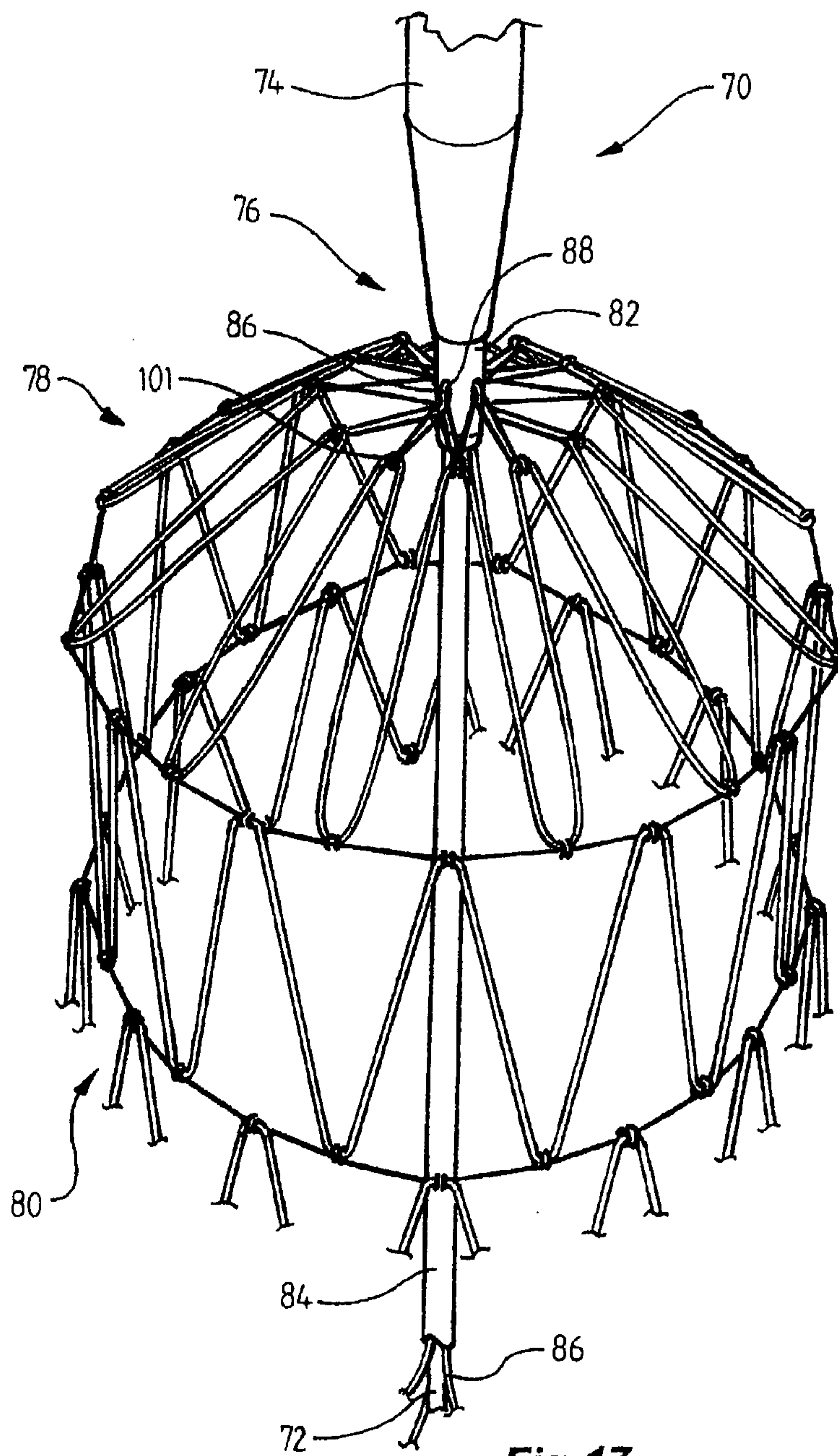

Fig 17

