

(19) World Intellectual Property Organization
International Bureau



(43) International Publication Date
11 June 2009 (11.06.2009)

PCT

(10) International Publication Number
WO 2009/073521 A2

(51) International Patent Classification:
A61M 25/088 (2006.01) A61B 17/34 (2006.01)
A61M 25/09 (2006.01) A61B 17/94 (2006.01)

(74) Agents: O'REGAN, Cecily, Anne et al.; Wilson Sonsini
Goodrich & Rosati, 650 Page Mill Road, Palo Alto, CA
94304-1050 (US).

(21) International Application Number:
PCT/US2008/084888

(81) Designated States (unless otherwise indicated, for every
kind of national protection available): AE, AG, AL, AM,
AO, AT, AU, AZ, BA, BB, BG, BH, BR, BW, BY, BZ, CA,
CH, CN, CO, CR, CU, CZ, DE, DK, DM, DO, DZ, EC, EE,
EG, ES, FI, GB, GD, GE, GH, GM, GT, HN, HR, HU, ID,
IL, IN, IS, JP, KE, KG, KM, KN, KP, KR, KZ, LA, LC, LK,
LR, LS, LT, LU, LY, MA, MD, ME, MG, MK, MN, MW,
MX, MY, MZ, NA, NG, NI, NO, NZ, OM, PG, PH, PL, PT,
RO, RS, RU, SC, SD, SE, SG, SK, SL, SM, ST, SV, SY, TJ,
TM, TN, TR, TT, TZ, UA, UG, US, UZ, VC, VN, ZA, ZM,
ZW.

(22) International Filing Date:
26 November 2008 (26.11.2008)

(25) Filing Language: English

(26) Publication Language: English

(30) Priority Data:
60/991,682 30 November 2007 (30.11.2007) US
61/033,368 3 March 2008 (03.03.2008) US
12/277,491 25 November 2008 (25.11.2008) US

(84) Designated States (unless otherwise indicated, for every
kind of regional protection available): ARIPO (BW, GH,
GM, KE, LS, MW, MZ, NA, SD, SL, SZ, TZ, UG, ZM,
ZW), Eurasian (AM, AZ, BY, KG, KZ, MD, RU, TJ, TM),
European (AT, BE, BG, CH, CY, CZ, DE, DK, EE, ES, FI,
FR, GB, GR, HR, HU, IE, IS, IT, LT, LU, LV, MC, MT, NL,
NO, PL, PT, RO, SE, SI, SK, TR), OAPI (BF, BJ, CF, CG,
CI, CM, GA, GN, GQ, GW, ML, MR, NE, SN, TD, TG).

(71) Applicant (for all designated States except US): TREUS
MEDICAL, INC. [US/US]; 330 Nimitz Avenue, Redwood
City, CA 94061 (US).

(72) Inventors; and

(75) Inventors/Applicants (for US only): VAN DAM, Jacques
[US/US]; 432 Portofino Drive #402, San Carlos, CA 94070
(US). MILROY, J., Craig [US/US]; 184 Heather Lane,
Palo Alto, CA 94303 (US). OHLINE, R., Matthew
[US/US]; 330 Nimitz Avenue, Redwood City, CA 94061
(US).

Published:
— without international search report and to be republished
upon receipt of that report



WO 2009/073521 A2

(54) Title: BILIARY SHUNTS, DELIVERY SYSTEMS, METHODS OF USING THE SAME, AND KITS THEREFOR

(57) Abstract: The application discloses devices, systems, kits and methods for treating biliary disease. Device comprise, for example, a component configured for deployment between a gallbladder and location within a gastrointestinal tract of a patient which has a proximal end and a distal end with a lumen extending therethrough. A method of deploying the device can be achieved by, for example, creating a duct or fistula between a gallbladder lumen and a portion of a gastrointestinal tract; and providing for drainage from the gallbladder to the gastrointestinal tract.

**BILIARY SHUNTS, DELIVERY SYSTEMS, METHODS OF USING THE SAME,
AND KITS THEREFOR****CROSS-REFERENCE**

[0001] This application claims the benefit of U.S. Provisional Application No. **60/991,682**, filed
5 November 30, 2007, and Application No. **61/033,368** filed March 3, 2008, which applications
are incorporated herein by reference.

[0002] This application has related subject matter to U.S. Utility Patent Application No.
12/277,338, filed November 25, 2008, entitled "Methods, Devices, Kits and Systems for
Defunctionalizing the Cystic Duct" by Jacques Van Dam, J. Craig Milroy, and R. Matthew
10 Ohline (identified as Attorney Docket No. 36233-701.203) and U.S. Utility Patent Application
No. **12/277,443**, filed November 25, 2008, entitled, "Methods, Devices, Kits and Systems for
Defunctionalizing the Gallbladder" by Jacques Van Dam, J. Craig Milroy, and R. Matthew
Ohline, which applications are incorporated herein by reference.

FIELD OF THE INVENTION

15 [0003] The invention described in this patent application addresses challenges confronted in the
treatment of biliary disease. Biliary disease includes conditions affecting the gallbladder, cystic
duct, and common bile duct.

BILIARY SYSTEM FUNCTION AND ANATOMY:

[0004] Bile is a greenish-brown digestive fluid produced by the liver **10** illustrated in **FIG. 1**, and
20 is vital for the digestion of fatty foods. Bile is secreted by liver cells and collected by a network
of ducts that converge at the common hepatic duct **12**. While a small quantity of bile drains
directly into the lumen of the duodenum **30** (the section of small intestine immediately
downstream of the stomach), most travels through the common hepatic duct **12** and accumulates
in the lumen of the gallbladder **14**. Healthy gallbladders are pear-shaped sacs with a muscular
25 wall that, on average, measure 10 cm in length and can store approximately 50 ml of fluid within
its lumen. When fatty foods are ingested, the hormone cholecystokinin is released, which causes
the gallbladder **14** to contract. Contraction of the gallbladder **14** forces bile to flow from the
gallbladder **14**, through the cystic duct **16**, into the common bile duct **18**, out the papilla **28**, and
finally into the duodenum **30** of the small intestine. Here, it mixes and reacts with the food that
30 exits the stomach. The Sphincter of Oddi **26** controls secretions from the liver, pancreas **24**, and
gallbladder **14** into the duodenum **30** of the small intestine. The opening on the inside of the
descending duodenum **30** after the Sphincter of Oddi **26** is called the major duodenal papilla **28**
(of Vater). Together, the biliary ducts, the gallbladder **14**, the cystic duct **16** and the common bile
duct **18** comprise the biliary system (**FIG. 1**).

[0005] The pancreas **24** is a gland organ in the digestive and endocrine system of vertebrates. It is both an endocrine gland (producing several important hormones, including insulin, glucagon, and somatostatin), as well as an exocrine gland, secreting pancreatic juice containing digestive enzymes that pass to the small intestine. These enzymes help in the further breakdown of the carbohydrates, protein, and fat in the chyme. The pancreatic duct **22**, or duct of Wirsung, is a duct joining the pancreas **24** to the common bile duct **18** to supply pancreatic juices which aid in digestion provided by the exocrine pancreas. The pancreatic duct **22** joins the common bile duct **18** just prior to the major duodenal papilla **28**, after which both ducts perforate the medial side of the second portion of the duodenum **30** at the major duodenal papilla.

BILIARY DISEASE:

[0006] The most common problem that arises in the biliary system is the formation of gallstones, a condition called cholelithiasis. Approximately 20 million Americans have gallstones, and about 1-3% will exhibit symptoms in any given year. In the U.S., gallstones are more common among women, with 25% of women having gallstones by the age of 60 and 50% by the age of 75. Pregnancy and hormone replacement therapy increase the risk of forming gallstones. Prevalence is lower for American men: approximately 25% will develop gallstones by the age of 75. In the U.S., gallstones are responsible for the highest number of hospital admissions due to severe abdominal pain.

[0007] Gallstones **20, 20'** are most often composed of cholesterol, but may also be formed from calcium bilirubinate, in which case they are called pigment stones. They range in size from a few millimeters to several centimeters, and are irregularly shaped solids resembling pebbles. They can form in the gallbladder **14**, cystic duct **16**, and/or the common bile duct **18** (**FIG. 2**). By themselves, gallstones **20** do not necessarily result in disease states. This is the case 90% of the time. However, stones can cause infection and inflammation, a condition known as cholecystitis, which is generally the result of restricting or blocking the flow of bile from the gallbladder **14** and common bile duct **18**, or the fluids secreted by the pancreas **24**.

[0008] Gallbladder disease may be chronic, and patients who suffer from this may periodically experience biliary colic. Symptoms include pain in the upper right abdomen near the ribcage, nausea, and/or vomiting. The pain may resolve within an hour of onset, may prove unresponsive to over-the-counter medicines, and may not decrease with changes of position or the passage of gas. Recurrence is common, with pain often recurring at the same time of day, but with frequency of less than once per week. Fatty or large meals may cause recurrence several hours after eating, often awakening the patient at night. Patients may elect to suffer from these symptoms for very long periods of time, such as years or even decades.

[0009] Patients with chronic cholecystitis have gallstones and low-grade inflammation.

Untreated, the gallbladder **14** may become scarred and stiff over time, leading to a condition called dysfunctional gallbladder. Patients who have chronic cholecystitis or dysfunctional gallbladder may experience gas, nausea, and abdominal discomfort after meals, and chronic
5 diarrhea.

[0010] Acute cholecystitis (a surgical emergency) develops in 1-3% of those with symptomatic gallstone disease, and is due to obstruction of the common bile duct **18** or cystic duct **16** by stones or sludge. Symptoms are similar to biliary colic, though they are more severe and persistent. Pain in the upper right abdomen can be constant and severe, the intensity may
10 increase when drawing breath, and it may last for days. Pain may radiate to the back, under the breastbone or the shoulder blades, and it may be perceived on the left side of the abdomen. In addition to nausea and vomiting, one third of patients experience fever and chills. Complications from acute cholecystitis can be serious and life threatening, and include gangrene, abscesses, perforation of the gallbladder **14** which can lead to bile peritonitis, pus in the gallbladder wall
15 (empyema), fistulae, and gallstone ileus (when a gallstone creates a blockage in the small intestine).

[0011] When gallstones **20'** become lodged in the common bile duct **18** (**FIG. 2**), the condition is known as choledocholithiasis. Symptoms for this condition include pain, nausea and vomiting, and some patients develop jaundice, have dark urine and/or lighter stools, rapid heartbeat, and
20 experience an abrupt drop in blood pressure. These symptoms can also be accompanied by fever, chills, and/or severe pain in the upper right abdomen. Complications from choledocholithiasis can also be very serious, and include infection of the common bile duct **18** (cholangitis) and inflammation of the pancreas **24** (pancreatitis).

[0012] A smaller patient population suffers from gallbladder disease that occurs in the absence
25 of gallstones. This condition, called acalculous gallbladder disease, can also be chronic or acute. Chronic acalculous gallbladder disease, also called biliary dyskinesia, is thought to be caused by motility disorders that affect the gallbladder's ability to store and release bile. Acute acalculous gallbladder disease occurs in patients who suffer from other serious illnesses which can lead to inflammation of the gallbladder **14** because of a reduction in the supply of blood to the
30 gallbladder **14** or a reduced ability to contract and empty bile into the duodenum **30**.

[0013] Cancer can also develop in the gallbladder **14**, though this condition is rare. Gallstones have been found in 80% of patients with gallbladder cancer. Gallbladder cancer typically develops from polyps, which are growths inside the gallbladder **14**. When polyps 15 mm across or larger are observed, the gallbladder is removed as a preventive measure. Polyps smaller than
35 10 mm are widely accepted as posing low risk and are not generally removed. When detected

early, before the cancer has spread beyond the mucosa (inner lining) of the gallbladder, the 5-year survival rate is approximately 68%. However, gallbladder cancer is not usually detected until patients are symptomatic, by which time the disease is more advanced.

TREATMENT OF BILIARY DISEASE:

5 [0014] The most effective treatment for biliary disease has been surgical removal of the gallbladder *14*, a procedure called cholecystectomy. Surgical removal of the gallbladder *14* is indicated for patients who experience a number of less severe gallstone attacks, cholecystitis, choledocholithiasis, pancreatitis, acalculous biliary pain with evidence of impaired
10 gallbladder *14* emptying, those at high risk for developing gallbladder cancer, and those who have previously undergone endoscopic sphincterotomy for common bile duct stones. Other treatment modalities exist and are frequently used, but gallbladder disease tends to recur in the majority of patients who forgo cholecystectomy and pursue alternatives. Removal of the gallbladder *14* is highly successful at permanently eliminating biliary disease. Cholecystectomy is one of the most commonly performed procedures on women. The gallbladder *14* is not an
15 essential organ, and after a period of adjustment post surgery, patients tend to return to more or less normal digestive function.

[0015] Cholecystectomy can be performed either as open surgery, which requires a single larger incision in the upper right abdomen, or laparoscopic surgery, in which several small instruments are inserted through much smaller incisions in the abdomen. Approximately 80% of
20 cholecystectomies are performed laparoscopically. The primary benefits of this minimally invasive approach are faster recovery for the patient, and a reduction in overall healthcare costs. Patients who receive laparoscopic cholecystectomy are usually released the same day. By contrast, patients receiving open cholecystectomies typically spend 5-7 days in a hospital before release. 5-10% of laparoscopic procedures convert to open procedures when difficulties arise,
25 such as injury to major blood vessels, inadequate access, inadequate visualization, previous endoscopic sphincterotomy, and thickened gallbladder wall. Complications from cholecystectomy (open or laparoscopic) include bile duct injuries (0.1-0.5% for open, 0.3-2% with a declining trend for laparoscopic), pain, fatigue, nausea, vomiting, and infection. In up to 6% of cases, surgeons fail to identify and remove all gallstones present.

30 [0016] In some cases, the degree of infection and inflammation prevents patients from undergoing immediate cholecystectomy. In these cases, the gallbladder *14* must be treated with antibiotics and anti-inflammatory agents, and drained through a tube into a reservoir outside the abdomen. Placement of this tube occurs in a procedure called percutaneous cholecystostomy, in which a needle is introduced to the gallbladder *14* through the abdomen, fluid is withdrawn, and
35 a drainage catheter is inserted. This catheter drains into an external bag which must be emptied

several times a day until the tube is removed. The drainage catheter may be left in place for up to 8 weeks. In cases where no drainage catheter is inserted, the procedure is called gallbladder aspiration. Since no indwelling catheter is placed, the complication rate for gallbladder aspiration is lower than that of percutaneous cholecystostomy.

5 [0017] Treatment methodologies other than cholecystectomy include expectant management, dissolution therapy, endoscopic retrograde cholangiopancreatography (ERCP) with endoscopic sphincterotomy, and extracorporeal shockwave lithotripsy (ESWL).

[0018] Expectant management is appropriate for patients who have gallstones but no symptoms, and for non-emergency cases with less severe symptoms. This approach is not recommended
10 when patients are in high risk categories (*e.g.* high risk for gallbladder cancer) or have very large gallstones (*e.g.* greater than 3 cm).

[0019] Oral dissolution therapy involves the administration of pills containing bile acids that can dissolve gallstones. This approach is only moderately effective, and the rate of recurrence of
15 gallstones after completion of treatment is high. It is not appropriate for patients with acute inflammation or stones in the common bile duct (more serious conditions). Dissolution therapy tends to be more effective for patients with cholesterol stones, and is sometimes used in conjunction with lithotripsy. Despite its relative ineffectiveness, it is costly: treatment can last up to 2 years and the drugs cost thousands of dollars per year.

[0020] Related to oral dissolution therapy is contact dissolution, a procedure that involves
20 injection of a solvent such as methyl tert-butyl ether (MTBE) directly into the gallbladder *14*. This approach is highly effective at dissolving gallstones, but patients may experience severe burning pain.

[0021] ERCP (endoscopic retrograde cholangiopancreatography) is a procedure in which an
25 endoscope is introduced through the mouth of a patient, past the stomach to the papilla *28*, where the common bile duct *18* empties into the duodenum *30*. The overall goal of the procedure is to insert instruments and tools into the common bile duct *18* via the papilla *28* in order to treat biliary disease. Typically, endoscopic sphincterotomy is performed, which is a procedure that enlarges the opening of the papilla *28* in the small intestine. This can be accomplished surgically or via balloon dilation. Contrast agent is introduced into the common bile duct *18* to visualize
30 the biliary tree fluoroscopically. Tools for clearing blockages, such as mechanical lithotripsy devices, can be deployed to crush gallstones and remove the resulting debris. Drainage catheters and stents may also be inserted to facilitate the drainage of bile past obstructions. Complications from this challenging procedure occur at a rate of 5-8%, and include recurrence of stone formation, pancreatitis, infection, bleeding, and perforation.

[0022] Extracorporeal shockwave lithotripsy (ESWL) is a technique in which focused, high-energy ultrasound is directed at the gallbladder 14. The ultrasound waves travel through the soft body tissue and break up the gallstones. The resulting stone fragments are then usually small enough to pass through the bile duct into the small intestine. Oral dissolution therapy is often used in conjunction with ESWL. This treatment is not in common use, as less than 15% of the patient population are good candidates. However, ESWL is used to treat patients who are not candidates for surgery. Complications from ESWL include pain in the gallbladder area, pancreatitis, and failure of the gallstone fragments to pass into the small intestine.

SUMMARY OF THE INVENTION

[0023] An aspect of the invention is directed to devices for treating biliary disease. Suitable devices comprise: a component configured for deployment between a gallbladder and a location within a gastrointestinal tract of a patient, the component having a proximal end and a distal end and a lumen extending therethrough. The devices can be configured for deployment by an endoscope, a needle, a guidewire, a guidance catheter, and/or a dilatation balloon. Endoscopes can further be adapted to comprise an ultrasound device. A system for treating biliary disease is also contemplated which comprises a device for configuring a duct between a gallbladder and a gastrointestinal tract of a patient having a proximal end and a distal end with a lumen extending therethrough between. In some aspects the devices can be configured to further comprise a delivery mechanism for delivering a substance. Deployment of these devices can, in some instances, cause a conduit to be formed between a gallbladder lumen and a target location within the gastrointestinal tract.

[0024] Another aspect of the invention is directed to a biliary disease treatment device comprising: an implant adapted to be delivered by an endoscope to a gastrointestinal site in proximity to a gallbladder, and further adapted to form a conduit between the gastrointestinal site and the gallbladder. The conduit can, for example, be formed between a lumen of the gallbladder and a target location within the gastrointestinal tract, such as proximal to a duodenum.

[0025] Devices according to any one of the configurations disclosed can be formed from a bioresorbable material. Moreover, the devices can be removable and/or expandable. The devices can also be configurable in one or more configurations selected from a deployment configuration, a delivery configuration and a final configuration. Moreover, the devices can be configured such that a profile of the device changes between said configurations. Additionally, or in the alternative, a cross-sectional area of the device can be variable along a length of the devices. In some configurations a component or implant can be configured such that it has a

flareable end, suitable flareable ends include ends that are generally hemispherical.

Additionally, components or implants can comprise a configurable retainable feature. In some aspects, components or implants can comprise one or more clips configured to secure the components or implants at one or more positions. In some configurations, one or more
5 fenestrations may be provided. Moreover, the lumen or conduit can be configurable to provide restrictable fluid flow or to provide for a valve, such as a flow-restrictor or one-way valve. Any of the configurations of the device can be constructed such that the device is flexible. The system or device can also be configured to include a generally elongate tube that is adapted and configured to extend into the gastrointestinal tract. Configurations that include an elongate tube
10 can be configured such that the tube is patent at a first end; the patent first end can be for placement adjacent the gallbladder. In still other configurations, the elongate tube is not patent at a second end. Moreover, the tube can be configured such that it has an adjustable length. Additionally, one or more fluid control components can be provided to the designs. Additionally, an enlargeable portion comprising two or more legs can be provided.

15 **[0026]** Another aspect of the invention is directed to a kit for treating biliary disease comprising a duct forming component positioned between a gallbladder and a gastrointestinal tract. The kit can comprise any of the devices or systems described herein. Additionally, compounds can be provided for delivery to a tissue. Compounds or materials include, but are not limited to, for example, one or more of each of sclerosing agents, antibiotics, inflammatory agents, anti-
20 inflammatory agents, biocompatible gels, and biocompatible foams. Additionally, a catheter, guidewire, needle, guidance catheter or balloon catheter can be provided. In some aspects, the kit can also include an ablation device. Additional components of the kits include, for example, one or more of each of a pair of scissors, a scalpel, a swab, a syringe, a hemostat, a lubricant, a needle, a snare, an antiseptic, and an anesthetic.

25 **[0027]** Yet another aspect of the invention is directed to a method for treating biliary disease. A method of treating biliary disease comprises: (a) creating a duct or fistula between a gallbladder lumen and a portion of a gastrointestinal tract; and (b) providing for drainage from the gallbladder to the gastrointestinal tract. Additionally, the method can comprise the step of
30 delivering a substance to the gallbladder via the duct. Additional method steps include delivering a device to the gallbladder through the duct. Suitable devices to be delivered include one or more of a stent, a drug-coated stent, a catheter, a needle, a guidance catheter, a balloon dilatation catheter and/or a guidewire. In some cases, the step of creating the duct further comprises the step of inserting a device in communication between the gastrointestinal tract and the gallbladder lumen. The step of creating the duct between a gallbladder lumen and a portion of a
35 gastrointestinal tract can further comprise the step of inserting a conduit between the gallbladder

lumen and the portion of the biliary system. In some aspects, the method further comprises the step of forming a biological duct *in situ* from a patient's tissue. As will be appreciated by those skilled in the art, the step of inserting a conduit between the gallbladder lumen and the portion of the gallbladder tract can occur at a first time and the step of forming the biological duct *in situ* from the patient's tissue occurs at a second time remote from the first time. Moreover the methods can further comprise the step of providing a seal to prevent fluid from leaking into a peritoneum. Additionally the gallbladder can be defunctionalized *in situ*, such as by delivering a substance or material into a space within the gallbladder. Suitable substances or materials include, but are not limited to, gels and foams. In some instances, the delivered substances can be activated *in situ*. Additionally, an amount of material can be delivered to fill, or substantially fill, the gallbladder lumen. Additionally, in some instances, the step of defunctionalizing is achieved by one or more of sclerosing or necrotizing a tissue within the gallbladder which can, for example, be achieved by an ablation technique.

[0028] Still another aspect of the invention is directed to a method of delivering a device to treat biliary disease comprising: (a) using an endoscope to place a guidewire between an access lumen in a body and a gallbladder; (b) inserting a delivery catheter over the guidewire and into the gallbladder; (c) delivering a conduit on the catheter; and (d) positioning the conduit between the access lumen in the body and the gallbladder to create a lumen therebetween. The methods can also include the step of forming a biological duct *in situ* from a patient's tissue. Additionally, the step of positioning the conduit can occur at a first time and the step of forming the biological duct *in situ* from the patient's tissue occurs at a second time remote from the first time. Some methods can further comprise the step of passively retaining a distal end of the guidewire in the gallbladder while the guidewire is used to deliver additional elements. In some instances, the methods include the step of retaining a distal end of the guidewire within the gallbladder. In some methods, gallstones are removed through the created lumen. In other methods, a substance is delivered to the gallbladder via the created lumen. In some instances, the substance occupies the gallbladder lumen and can be one or more of antibiotics, inflammatory agents, and anti-inflammatory agents. Methods may also include preventing bile from entering the or a gallbladder lumen. Additionally, the gallbladder may be localized via endoscopic ultrasound, in some instances. Moreover, it may be useful to access the gallbladder via the gastrointestinal tract. A suitable location for accessing the gallbladder via the gastrointestinal tract would be to access the gallbladder at a duodenum. With any of the methods it may be desirable to alter and/or remove gallstones. Moreover, other obstructions within the biliary system can also be removed. The delivered conduit can be, for example, one or more of a stent, and a drug-coated stent. In some applications of the methods, biliary disease is treated without removal of the

gallbladder. In still other applications of the method, a treatment area is visualized as part of the method. In some methods, the conduit is anchored in place. In still other methods, the conduit is changed from a delivery configuration to a deployment configuration, from a delivery configuration to a final configuration or from a deployment configuration to a final configuration. Still other methods provide for reducing a cross-sectional profile of the conduit, providing a seal to prevent fluid from leaking into a peritoneum, and/or restricting fluid flow from the gallbladder lumen to the gastrointestinal tract. Other methods include operating a valve to restrict fluid flow.

INCORPORATION BY REFERENCE

[0029] All publications, patents, and patent applications mentioned in this specification are herein incorporated by reference to the same extent as if each individual publication, patent, or patent application was specifically and individually indicated to be incorporated by reference.

BRIEF DESCRIPTION OF THE DRAWINGS

[0030] The novel features of the invention will be set forth with particularity in any claims presented based on this application. A better understanding of the features and advantages of the present invention will be obtained by reference to the following detailed description that sets forth illustrative embodiments, in which the principles of the invention are utilized, and the accompanying drawings of which:

[0031] FIG. 1 illustrates an overview of the biliary system;

[0032] FIG. 2 illustrates the biliary system with gallstones;

[0033] FIG. 3 illustrates an endoscope accessing the biliary system via the intestinal system;

[0034] FIGS. 4A-D illustrate embodiments of a device adapted to provide a conduit between two body lumens;

[0035] FIGS. 5A-B illustrates the outward radial force applied by an embodiment of a device adapted to provide a conduit between two body lumens;

[0036] FIGS. 6A-B illustrates an embodiment of a device with a retaining feature;

[0037] FIGS. 7A-G illustrate variations of retaining features;

[0038] FIGS. 8A-B illustrate another variation of a retaining feature;

[0039] FIGS. 9A-C illustrates a delivery configuration which reduces cross-sectional area;

[0040] FIGS. 10A-B illustrates an alternate embodiment of a device;

[0041] FIG. 11 illustrates an alternate embodiment of a device having an elongate tube;

[0042] FIGS. 12A-C illustrate an alternate embodiment formed from shape memory material;

[0043] FIGS. 13A-G illustrate a close-wound spring embodiment of the device;

[0044] FIGS. 14A-B illustrates a stent-like embodiment;

[0045] FIGS. 15A-B illustrate retaining features;

[0046] FIGS. 16A-E illustrate a variety of valve embodiments;

[0047] FIGS. 17A-B illustrate a variety of plug embodiments;

[0048] FIGS. 18A-I illustrate delivery of a device according to the invention via a catheter;

5 [0049] FIG. 19 illustrates the steps of delivering a device according to the invention via a catheter;

[0050] FIG. 20 illustrates delivery of a device according to the invention at the distal tip of an endoscope; and

[0051] FIGS. 21A-H illustrate a guidewire retention feature.

10

DETAILED DESCRIPTION OF THE INVENTION

[0052] Devices, systems, methods and kits provided herewith can obviate the need for a plurality of procedures, including, for example: 1) percutaneous cholecystostomy, 2) cholecystectomy, 3) percutaneous trans-hepatic cholangiography (PTHC), and 4) endoscopic retrograde cholangiopancreatography (ERCP). Additionally, disclosed treatment modalities enable
15 treatment of a distal common bile duct *18* obstruction, *e.g.* secondary to pancreatic carcinoma, cholangiocarcinoma, and/or ampullary carcinoma. As will be appreciated by those skilled in the art, the conventional standard of care for treating biliary disease has been surgical removal of the gallbladder *14* and closure of the cystic duct *16*. While this has proven to be an effective mechanism for permanently eliminating biliary disease and its recurrence, the present invention
20 seeks to accomplish the same end in a less invasive and less costly way. This may be achieved by treating biliary disease without requiring the removal of the gallbladder *14*. Methods and apparatus are described in this application that are intended to effectively treat biliary disease with the gallbladder *14* and cystic duct *16* left *in situ* by providing a shunt to the gallbladder.

[0053] A method of treating biliary disease involves using an endoscope *310* to access a region
25 *350* in the gastrointestinal (GI) tract (FIG. 3) to which the gallbladder *14* is in close proximity, locating the gallbladder *14*, accessing the gallbladder *14*, and then treating the underlying condition that led to the need for intervention (FIG. 3). Treatments may also include, but are not limited to: providing for drainage of the gallbladder *14* and/or the biliary tree, delivering suitable materials or substances, such as antibiotics, inflammatory, anti-inflammatory agents (any of
30 which may be short-term acting, fast acting, or time release), and/or other substances (*e.g.* adhesives, bioadhesives, *etc.*) to the gallbladder *14* and/or biliary tree, removing gallstones *20*, facilitating the destruction and subsequent removal of gallstones, clearing obstructions, delivering catheters, delivering stents (drug coated or not drug coated), temporarily or permanently defunctionalizing the cystic duct *16*, temporarily or permanently defunctionalizing

the gallbladder **14**. Devices and therapies can be delivered in a single treatment, with minimal likelihood of or necessity for follow-up or repeat procedures.

[0054] The gallbladder can be accessed by any suitable mechanism or procedure including, percutaneously, endoscopically, laparoscopically, and the like. Moreover, any of the materials and substances delivered to the gallbladder can be delivered concurrently or sequentially. Delivery of substances can occur sequentially in time or the sequence of delivery can be separated by seconds, minutes, or hours.

[0055] Localization of the gallbladder **14** can be performed via endoscopic ultrasound (EUS) by accessing the wall of the GI tract with an endoscope **310** as shown in FIG. 3. Localization may also be achieved by any other method that visualizes anatomical features, such as fluoroscopy, x-rays, magnetic resonance imaging (MRI), computed axial tomography (CT) scans, ultrasound imaging from outside the body, or any method of anatomical imaging and visualization.

[0056] Once the gallbladder **14** has been located, it may be accessed and/or treated **350** through the wall of the GI tract (or any lumen in proximity to the gallbladder **14**) with tools and devices (e.g. needles, guidewires, guidance catheters, dilators, etc.) delivered through, for example, an endoscope **310**. Such tools and devices may be inserted down the length of the endoscope's working channel **312**, or loaded onto or near the distal end of the endoscope **310**. Alternately, tools and other devices may be used that do not require the aid of the endoscope for navigation or delivery. Direct visualization may be provided by the endoscope **310** during the procedure, as well as irrigation, suction, and insufflation.

[0057] Though the preferred location for accessing the gallbladder lumen is the duodenum **30**, it may also be readily achieved through the wall of other regions of the GI tract, such as the stomach or the jejunum, for example. Thus, any lumen in close proximity to the gallbladder **14** is a candidate for access to and treatment of the gallbladder **14** and other members of the biliary system.

DESCRIPTION OF THE DEVICES:

[0058] In the present invention, *in situ* treatment of the gallbladder **14** is enabled via the creation of a passageway between the gallbladder lumen and a lumen in close proximity, e.g. at or near the duodenum. This passageway or duct may be created by an implantable device **420**, such as those illustrated in FIG. 4.

[0059] The passageway may be temporary or permanent. It may be thought of as a fistula that is intentionally created between the gallbladder **14** and another lumen in proximity, as described above. Alternately, it may be thought of as a stoma between the gallbladder **14** and another lumen in proximity. The passageway serves as a conduit, an access port, through which a

number of actions may be accomplished, drainage may be achieved, and treatments may be delivered.

[0060] A device 420 forming the passageway may be left in the patient for a short period of time, such as a few hours, a few days or a few weeks, or it may be left in place for extended periods of time, such as several weeks, months, or years. The device 420 may also be left in place permanently. If it is left in place long-term, tissue may form around the device 420, creating a fistula that connects the gallbladder 14 to the access lumen which may persist even if the passageway device 420 is removed, thus forming a biological *in situ* device 420 from the patient's own tissue. The fistula may be beneficial and useful, as it may continue to allow drainage for the contents of the gallbladder 14 into the small intestine. It may provide either the primary or a secondary mechanism for delivering bile into the digestive system, for example. It may also provide convenient access in cases where repeated treatments are required. Though there may be no need to close the resulting fistula, it may also be closed at any time by a clinician should this become desirable. After removal of a device 420 that initially formed the passageway, a fistula may remain open for a period of time and then close on its own, and may pose no additional risk and prove to be an acceptable course of events. Whether the device 420 is left in place or removed, and whether the fistula is left open or closed, evidence at the site may serve to mark the location of treatment in the event of future procedures.

[0061] To facilitate delivery and deployment of a device 420, it may be useful to reconfigure its shape. For example, the cross-sectional area presented by the device 420 at various locations may be reduced, thus, for example, reducing its overall profile. In cases where the configuration of the device 420 is caused to change, it may be helpful to conceive of the device 420 having one or more configurations, for example: one configuration when it is delivered (a "delivery configuration"), another configuration when it is deployed (a "deployment configuration"), and yet another configuration when it is in place and functional (a "final configuration"). Still other configurations may also be necessary or useful. For the delivery configuration, it may be advantageous to alter (*e.g.* reduce) the cross-sectional area or profile, so that it more easily fits delivery mechanisms, such as the working channel of an endoscope 310 (illustrated in FIG. 3). During deployment, the configuration of the device 420 may be altered so that placement into the patient is facilitated. This may be different from both the delivery configuration and the final configuration, though this is not necessarily the case. As will be appreciated by those skilled in the art, one or more configurations can be the same or substantially the same.

DESCRIPTION OF THE CONDUIT:

[0062] The preferred embodiment of the conduit is that of a short tube that is flared into hemispherical bowl-like shapes at both ends, as depicted in FIG. 4. The flared bowl-like shapes

at the distal end **422** and the proximal end **425** secure the conduit device **420** in the desired location within the gallbladder **14** and the access lumen, *e.g.* the duodenum **30**. The conduit **420** forms the proposed passageway **424** between the gallbladder **14** and the body lumen from which it will be accessed, such as through the duodenum **30**. The tubular portion **430** of the conduit

5 **420** is typically about 4-10 mm in length $h1$, with an inner diameter $w1$ of the device lumen or passageway **424** large enough to facilitate drainage and access, typically in the range of 2-10 mm. However, other dimensions can be used without departing from the scope of the invention. The outer diameter of the tubular portion **430** of the conduit **420** is typically larger than about 3 mm (10 French) in its final configuration. A variation of the preferred embodiment, depicted in

10 **FIG. 4B**, comprises a short tube which is bent at an angle, rather than straight, which may beneficially accommodate anatomical variations. Another variation of the preferred embodiment, depicted in **FIG. 4C**, comprises a longer tube which may allow for relative motion between the gallbladder and the connected lumen, while maintaining patency of the conduit. This configuration may optionally include additional retaining features: a first **415** which is

15 proximal to the distal retaining feature **422** and a second **419** which is distal to the proximal retaining feature **425**. These additional retaining features serve to secure the tissue of the gallbladder wall and the connected lumen (*e.g.* the wall of the duodenum) and prevent leaks even as the structures undergo relative motion. **FIG. 4D** shows another variation in which the tube comprises a series of loops so that the distance $h1$ between the distal retaining feature **422** and

20 the proximal retaining feature **425** may change without applying excessive force to the tissue adjacent to the anchors. As shown in **FIG. 5**, the tubular portion **530** may have radial compliance so that it presses gently but positively outward against the tissue it penetrates. When the original hole in the lumens' walls is smaller than the diameter of the conduit's tubular portion **530** in its final configuration, the tissue will squeeze down around the device **520** as the tube **530** generates

25 outward radial force F . This will facilitate sealing, and prevent bile and/or other fluids from leaking into the peritoneum. The flared features **422** and **425**, as illustrated in **FIG. 4** serve to secure the conduit **520** in place, as well as provide slight tension to approximate the gallbladder **14** wall to the wall of the body lumen providing access. The soft and compliant nature of the preferred materials also provide for a measure of relative motion between the gallbladder **14** and

30 connected lumen, which may increase the comfort of the patient. These retaining features **422** and **425** at either end of the device **420**, as illustrated in **FIG. 4**, have preferred dimensions of approximately 25 mm diameter at their widest point $w2$, and are approximately hemispherical in shape so that their effective height $h2$ is approximately 12.5 mm. They may be co-molded or made as one piece together with the tubular portion **430**.

[0063] A variation on this embodiment includes an integral retaining feature **622** on one end of the device's tubular portion **630**, but does not include it on the opposing end as shown in **FIG. 6**. In this configuration, the integral retaining feature **622** is compressed down to a minimal profile for delivery, and then allowed to expand outward during deployment. Once the device **620** is in the desired location, a retaining clip **628** may be added over the end of the tube **630** that has no integral retaining feature. The retaining clip **628** may have a single location on the tube **630** where it is securable, or it may be adjustable so that the clip **628** may be secured in a variety of locations **631**. This provides for adjustability of the compression applied to the walls of the body lumens approximated by the conduit **620** (the gallbladder wall and the wall of the adjacent lumen, such as at or near the duodenum **30**).

[0064] The retaining feature **422** and **425** (**FIG. 4**) located at either one end (as illustrated in **FIG. 6**) or both ends (as illustrated in **FIG. 4**) of the tubular portion **430** of the device **420** may be embodied in a number of different shapes. The hemispherical flared retaining feature **422** provides a measure of separation between the entry of the tubular portion **430** of the conduit **420** and the body lumen in which it resides. This may be useful in cases where it is undesirable for the contents of the body lumen to enter the conduit **420** directly (*e.g.* inside the duodenum **30**, it may be undesirable for partially digested food to enter the conduit **420**). When this bowl shaped retaining feature **422** is suspended upside down or sideways, it is especially effective at preventing ingress of undesirable matter. However, other configurations that provide less separation between the conduit **420** and the body lumen may be useful. Other designs may allow for less restricted flow of fluid from within a body lumen into the lumen of the conduit **420**. This may be useful, for example, inside the gallbladder **14**, where complete drainage of bile may be beneficial. An alternate embodiment based on the previously-described hemispherical shape is that of a bowl **722** with slots **732** (**FIG. 7A**). Another embodiment is a hemispherical shape **722** that has apertures or holes **734** incorporated into it so that it is fenestrated (**FIG. 7B**). The incorporation of fenestrations may be applied to any shape to allow for flow, *e.g.* globes, tubes, *etc.*

[0065] Shapes other than hemispherical bowls may also have useful properties. One such embodiment is that of a flat, or nearly flat, plate as an anchoring feature **722**. This is illustrated in **FIG. 7C(1)**. One advantage of this flat or nearly flat shape is that most or all of the fluid inside the lumen where it resides (*e.g.* the gallbladder **14**) may pass into the conduit **720**, and there will be little or no void or dead space where fluids may pool and fail to flow. The edges of a flat or nearly flat retaining feature may be rounded or curled up slightly in order to prevent trauma to adjacent tissue, **FIG. 7C(2)**. Another variation of the shape of the anchoring or retaining feature **722** is configured so that it resembles lines of longitude of a globe, as shown in **FIG. 7D**. In this

configuration, at least two legs 738, 738' are included (forming a complete circle), but four or more legs may be incorporated (forming two or more circles). Odd numbers of legs 738 may be incorporated, with the semicircles joined at the base 721 (the connection to the tube) and the apex 723 (the location farthest from the tube). In order to reconfigure this design to have a small cross-sectional area, which may be useful for delivery, the apex 721 may be pushed away from the tube 730, which will collapse the globe shaped retaining feature 722 into a linear configuration. This may be achieved with the use of a wire (not shown) or any other element which may push the apex 721 away from the tube 730. Another embodiment of the retaining feature 722 at the end(s) of the conduit's tubular portion resembles the shape and organization of a flower's petals 740. The petals 740 are joined at the point where they contact the tube 730 (similar to the flower's stem), and spread outwards when unconstrained, as shown in FIG. 7E. These may also be reconfigured in order to reduce the cross-sectional area, which may be useful during delivery of the device 720, and then caused to spread outwards once the device 720 is delivered and in a suitable orientation for its final configuration. Another embodiment of a device 720 has a retaining feature 722 that resembles the extensible portions of a drywall anchor or toggle, as shown in FIG. 7F. In this configuration, the retaining feature's default (unconstrained) configuration is fully extended, so that the cross-sectional area is reduced. When desired, *e.g.* after delivery or during deployment, the apex 723 of the extensible portions of the retaining feature may be drawn in towards the tubular portion 730 of the conduit 720, spreading out a set of legs 738 in the process. The apex 723 may be drawn in by pulling on a wire (not shown), for example, or any other element adaptable to apply tension at the apex 723. Alternately, the retaining feature's default (unconstrained) configuration may be fully contracted, so that the cross-sectional area is maximized. In this case, a wire or similar element may be used to push the apex 723 away from the tubular portion 730 of the conduit 720 to reduce the cross-sectional area for delivery.

[0066] In yet another embodiment of a device according to the invention, a retaining feature 722 has an increase in the outer diameter of the tube 730 comprising the conduit 720 (FIG. 7G). This embodiment may be configured to have a consistent outer diameter during delivery and deployment, and then configured to have an increased outer diameter for its final configuration 722, which serves to secure the conduit 720 within the body lumen.

[0067] In still another embodiment of a retaining feature 822, the device 820 is shaped in such a way that it may be pushed through a wall of a body lumen or lumens directly, and then rotated into position along with the conduit 820, to secure the two body lumens together and hold the conduit 820 in place, as illustrated in FIG. 8A. As illustrated in FIG. 8B, the retaining feature in this embodiment may be divided into more than one element 822, 822' and 825, 825', and these

elements 822', 825' may be rotated radially to better secure the conduit 820 once it is in position.

As shown, pairs of elements 822, 822' and 825, 825' are spread out to hold the conduit 820 in place, however any number of elements 822 and 825 greater than or equal to one could be used without departing from the scope of the invention.

5 [0068] As shown in FIG. 9A, a method for altering the configuration of the device 920 to facilitate delivery is to elongate the device 920. If the device 920 is sufficiently elongated, the cross-sectional area will be reduced, in some cases substantially. Once the device 920 has been elongated and its cross-sectional area reduced, it may be loaded into a sheath, capsule, or other dimensional retaining component 942 so that this low profile configuration is maintained until it is desirable to alter the configuration, such as when the device 920 is deployed or delivered *in situ*. Alternately, the device 920 may be compressed or elongated and then constrained by tightly wrapping or tying it with string or wire. Suitable materials for these techniques include, but are not limited to, shape memory alloys (SMA) such as Nitinol®, and cross-linked polyethylene. Another means of altering the configuration of the device 920 to facilitate delivery is to construct it so that its initial shape is that of a series of loops resembling a corkscrew, FIG. 9B. The device may be straightened and then constrained for delivery, or it may be rotated into the preferred position once the distal end has been inserted through the walls of the lumens. This configuration may incorporate at least one loop (FIG. 9C), and tissue may be retained and constrained between any two adjacent loops 922 and 931.

20 [0069] The conduit may be made of any suitable biocompatible material that is elastic and soft. Silicone is the preferred material. Other materials may optionally be used, *e.g.* polytetrafluoroethylene (PTFE), expanded PTFE, other members of the fluoropolymer family, urethanes, polyurethanes, and others. The materials can, for example, be soft at body temperature, with durometer typically in the range of 20-60 A. Softer materials are easier to deliver and reduce the risk of injury to adjacent tissue. A suitable material is, for example, soft enough to compress to a compact size for delivery and deployment.

[0070] Embodiments of retaining features 722, 822 may be comprised of compliant polymeric material (*e.g.* silicone). If they are comprised of soft, compliant materials, the retaining features 722, 822 can readily bend and deform to accommodate the passage of large items through the conduit 724, 824 formed between a first body lumen and a second body lumen, *e.g.* the gallbladder 14 and the duodenum 30. Alternately, the retaining features 722, 822 may be formed from less compliant material or a metal (*e.g.* Nitinol or stainless steel). The retaining features 722, 822 may be formed integrally with other elements of the overall conduit device 820, such that the components are formed to act in a unified manner by formation as a single component, or may be separate from the other elements of the overall conduit device 820. The retaining

35

features **722**, **822** may be incorporated into the overall assembly during manufacturing, or the parts may be installed by a clinician user prior to use in a patient or during deployment of the device **820** within a patient.

[0071] The device **820**, or other devices described herein, may also be comprised of a biodegradable, bioabsorbable, or resorbable material, in which case it may dissolve within the mammalian body within a desirable and useful length of time. This could eliminate the need for follow-up procedures to remove the device **820** at the end of a course of treatment.

Manufacturing the device **820** from such a material may not prevent clinicians from actively removing it if the need arose, however. Rather, it would prevent the need to actively remove it in cases where no other treatment was required.

[0072] The conduit **1020** may be comprised of a single component and a single material, or it may be an assembly of different components, some of which may be of different materials that are integrally formed to act or perform in a unified manner once deployed. For instance, a conduit **1020** may be comprised of an SMA spring form **1052**, over which silicone **1054** (or another suitable polymer material) is molded as illustrated in FIG. 10. The spring form **1052** serves to lend the conduit structure and dimensional stability, while the silicone (or other polymer) outer shell **1054** creates soft surfaces which are unlikely to cause injury to tissue and facilitate sealing of the device **1020 in situ** and prevent leaks. If SMA materials are used, their transition temperatures can be selected to be slightly below body temperature, so that they can be designed to hold one shape for delivery and deployment, and, after transitioning, they will have the desired shape(s) for optimizing the function of the conduit. Alternately, the SMA material may be used in its superelastic state.

[0073] As shown in FIG. 11, an alternate embodiment of the conduit device **1120** is formed from an elongate tube **1130** which incorporates a retaining feature **1122** to secure a distal end **1102** (the end within the lumen of the gallbladder **14**), a distal end **1102** with sufficient structure to maintain the conduit tube's **1130** patency, a proximal end **1104** that may lack sufficient structure to maintain the conduit tube's patency, and/or an overall length **L1** sufficient to deliver bile from the gallbladder **14** into the duodenum **30** a length downstream of the location that the duodenum **30** and the gallbladder **14** are connected by the conduit **1120**. If the conduit **1120** is configured so that patency of the proximal end **1104** is not maintained, the tube **1130** may be thought of as highly flexible so that it may be easily moved and/or deformed by materials such as chyme **1139** moving through the small intestine. Downstream delivery of bile into the duodenum **30** may be desirable to prevent bile reflux, a condition that occurs when bile enters the patient's stomach and/or esophagus. For such an embodiment, the length of the tube **1130** may be adjustable. For example, the conduit may be placed into the gallbladder **14** and then trimmed to the desired

length. Alternatively, the conduit *1120* may be made available to clinicians in a variety of lengths.

[0074] Another alternate embodiment of the conduit device *1220* as illustrated in FIG. 12A, is comprised entirely of SMA, such as Nitinol. In this embodiment, the radial dimensions of the conduit's tubular portion *1230* may be reducible to facilitate delivery. Methods of achieving this include, but are not limited to: cutting the tube wall parallel to its central axis x and rolling the material tightly to reduce the diameter d for delivery, then expanding it to a greater diameter D and rejoining the edges to form a complete and sealed tubular structure at deployment; simply folding or radially collapsing the tube *1230* to a smaller outer diameter $d1$ which may be the minimum possible radial dimension from which the SMA material can fully recover its desired tubular diameter $d2$ and shape at deployment (FIG. 12B); forming the tube *1230* into a polygon which, in its collapsed configuration folds in an "asterisk" pattern to present minimal cross-sectional area with diameter $d1$, and in its expanded configuration is a polygon approximating a circular cross-section with diameter $d2$ (FIG. 12C). For the configuration depicted in FIG. 12C, the number of sides of the polygon can vary, with higher numbers of sides resulting in beneficial characteristics such as the device *1220* more closely approximating a circular cross-section when expanded and collapsing to smaller sizes to facilitate delivery and deployment.

[0075] Turning now to FIG. 13, an alternate embodiment is depicted that may be comprised entirely of SMA or other material is that of a close-wound spring. The spring *1352* may be formed by tightly coiling a wire-shaped material, such as Nitinol, other SMA material, stainless steel, titanium, or other suitable material so that it forms a coil as shown in FIG. 13A. This coil *1352* shares characteristics with an extension spring: if tension is applied at the ends of the component, the coils are caused to separate, and this results in the spring creating a compressive return force F . When no external tension is applied to the coil, the gaps between the individual winds of the coil are minimal, and these gaps may be maintained by residual compressive forces imparted to the material during manufacturing as shown in FIG. 13B. To configure such an embodiment for delivery, a tensile load F may be applied, and/or the proximal and distal ends of the spring may be rotated relative to each other T , greatly increasing the length of the device *1320*, decreasing the cross-sectional area and diameter d accordingly as shown in FIG. 13C.

Once the device *1320* is in the desired configuration for delivery, it may be loaded into a sheath or other retaining component as shown in FIG. 13D so the configuration is maintained until it is desirable to alter the configuration, such as when the device *1320* is deployed. A variation of this embodiment includes a coating *1354* of the material comprising the spring *1352* with a soft, easily deformable polymeric material, such as (but not limited to) silicone, PTFE, or EPTFE as illustrated in FIG. 13E. This could also be achieved by overmolding the polymeric material onto

the spring. This coated spring device **1320** has the characteristics described above, as well as the advantages of a soft, compliant, sealed surface: *e.g.* the potential for bile leaks is reduced (as well as other fluids), and a reduction of the likelihood of injury to surrounding tissue by the device **1320** or the acts of delivering and deploying the device **1320**. Alternately, the spring **1352** could be located outside the soft, compliant material **1354**, as illustrated in **FIG. 13F**, or inside, as illustrated in **FIG. 13G**.

[0076] In another embodiment, the structure of the conduit's tubular portion **1430** may be comprised of SMA (such as Nitinol or other suitable material) or non-SMA material (*e.g.* stainless steel or polymeric material) in the form of a stent as shown in **FIG. 14**. The stent **1420** may be covered or may cover another material (such as silicone or EPTFE, as described above) so that it provides a sealed passageway between the gallbladder **14** and the connected body lumen. During delivery, the stent **1420** presents a very small cross-sectional area with initial outer diameter d . During deployment, the stent **1420** is caused to expand outwards against the hole in the walls of the body lumens it connects together. This outwards, radial force of the device **1420** and increase in outer diameter D may be optimized in such a way as to reduce the risk of leaks between the gallbladder **14**, the connected body lumen, and the surrounding anatomy.

[0077] Leaks may also be prevented by coating the external surfaces of any conduit design with a suitable adhesive, such as one that is biocompatible. Such an adhesive serves to bond the device **1420** to the tissue it contacts, and prevents gaps which may otherwise allow fluid to escape from either lumen or the conduit itself.

[0078] The conduit's retaining features **1522** located at either end may also be comprised of SMA (*e.g.* Nitinol) or other suitable non-polymeric material. This may be the case whether the tubular portion **1530** of the conduit **1520** is formed from the same or from different materials. Such retaining features may take on a number of shapes and configurations. **FIG. 15A** shows one embodiment in which the retaining features **1522** resemble spring form fingers **1558**, spread out in a flared pattern from the ends of the conduit's tubular portion. During delivery, the fingers **1558** are compressed in towards the central axis x of the tube **1530** to reduce the profile. Upon deployment, the fingers **1558** are allowed to spread outwards to function as a retaining feature **1522**. **FIG. 15B** and **FIG. 15C** show other embodiments in which the retaining feature **1522** comprises an element **1558** in a spiral configuration that resembles a corkscrew, with a variable outer diameter. During delivery, this spiral is compressed to reduce its profile, and upon delivery it is caused to expand outwards to serve the purpose of retention.

[0079] To ensure that material is only allowed to travel through the conduit from the gallbladder **14** into the lumen connected via the conduit, *e.g.*, the duodenum, and not in the reverse direction,

a valve **1660** may be incorporated into or attach onto the conduit device **1620**. For instance, it may be desirable to deliver bile into the digestive tract, and to drain pus or other fluids, but undesirable for partially digested food to move from the small intestine into the gallbladder **14**. A valve may be used to prevent flow into the gallbladder **14** from sources other than the biliary system. This is illustrated in **FIG. 16**. Among the purposes of the valve **1660**: allow the movement of material from the gallbladder **14** into the body lumen (e.g. a duodenum **30**) connected by the conduit **1620**, prevent flow in the reverse direction, and control the level of pressure that is allowed to develop within the gallbladder **14**. Controlling the pressure within the gallbladder **14**, and ensuring that the pressure differential between the gallbladder **14** and the connected body lumen remains low, reduces the risk of the bladder's contents (e.g. bile) leaking into the peritoneum. Bile leaks can result in bile peritonitis. The valve **1660** may be incorporated or added at any location within the conduit, from the most distal end (the farthest end inside the gallbladder **14**) to the most proximal end (the closest end inside the connected lumen), as shown in **FIG. 16A**. The valve may be made of any suitable material, such as the materials used to construct the conduit. The preferred material for this purpose is silicone. However, it may also be made of any other suitably biocompatible compliant material (in cases where bending characteristics of the material are used to create the flow control feature) or non-compliant material such as stainless steel, nickel-titanium alloy, or titanium (in cases where mechanical elements are used to create the flow control feature). The preferred embodiment is that of a duckbill valve illustrated in **FIG. 16B**, with a slit in a cone-shaped compliant material that supplies elastic forces that cause it to be closed under normal circumstances, open when the pressure in the gallbladder **14** exceeds the pressure in the connected lumen (e.g. during contraction of the gallbladder **14**) by a desired amount, and closed if the pressure in the connected lumen is higher than the pressure in the gallbladder **14** (a condition that might otherwise result in flow in the undesirable direction). In an alternate embodiment, the valve may be designed as a sprung flap (**FIG. 16C**), with functional characteristics similar to those of the duckbill valve described above. Another embodiment is that of a bicuspid valve (**FIG. 16D**) or tricuspid valve (**FIG. 16E**), which also exhibit the characteristics of allowing flow from the gallbladder **14** into the connected body lumen, but not in the reverse direction. Each of these embodiments, and other valve embodiments not specifically described herein, share the flow control characteristics of a) allowing flow from the gallbladder **14** into the body lumen connected through the conduit **1620** when the pressure in the gallbladder **14** is greater than the pressure in the connected lumen by a desired amount, b) not allowing flow from the connected lumen into the gallbladder **14** when the pressure in the lumen exceeds the pressure in the gallbladder **14**, and

c) not allowing flow between the gallbladder *14* and the connected lumen when little or no pressure differential exists between the two bodies.

[0080] An adjustable valve *1660* may also be incorporated into or added to a conduit *1620*.

Such a valve would enable practitioners or patients to adjust the difference in pressure between the gallbladder *14* and the connected lumen (such as the duodenum) at which the valve opens.

Adjustability may be incorporated into the valve body in such a way that a clinician may adjust it endoscopically, or it may be incorporated in such a way that a clinician or the patient may adjust the valve without requiring additional endoscopy or invasive procedure.

[0081] Another approach to controlling flow between the gallbladder *14* and a connected body lumen is to incorporate or allow for the installation of a blocking mechanism or plug to close off the conduit. This may be in addition to, instead of, or interchangeable with a valve *1660*, as described above. The plug may allow for temporary or permanent blockage of the passageway between the gallbladder *14* and the connected body lumen created by the conduit. One embodiment of such a plug is as a diaphragm *1770* or membrane (FIG. 17A) that allows for short term access to the gallbladder *14* through the conduit by puncturing the material at the center of the block. This may be accomplished, for example, with a needle or fine catheter. The material of the diaphragm or membrane may be selected so that it is self-healing, and as such is re-sealable. This may allow for multiple instances of puncture and hence able to be used for repeated access. Another embodiment of such a plug *1770* is that it is installable, removable and/or replaceable (FIG. 17B). These functions may be performed endoscopically.

DELIVERY OF MATERIALS OR SUBSTANCES TO THE GALLBLADDER

[0082] In some aspects it may be desirable to deliver one or more materials, such as fluids or gases, to the interior of the gallbladder lumen either before or after delivery of any of the devices disclosed herein. Moreover, any of the materials and substances delivered to the gallbladder can be delivered concurrently or sequentially. Delivery of substances can occur sequentially in time or the sequence of delivery can be separated by seconds, minutes, or hours.

[0083] An amount of fluid, gas, or material delivered as described throughout can be such that it fills the gallbladder, substantially fills the gallbladder (*e.g.*, fills more than 50% of the gallbladder, more than 75% of the gallbladder, more than 85% of the gallbladder, more than 90% of the gallbladder, more than 95% of the gallbladder, or more than 99% of the gallbladder) or is activatable to fill or substantially fill the gallbladder. Alternatively, in some instances, *e.g.*, the amount of fluid, gas, or material delivered as described throughout can be such that it coats the interior lumen of the gallbladder, or substantially coats the interior lumen of the gallbladder (*e.g.*, coats more than 50% of the gallbladder, more than 75% of the gallbladder, more than 85% of the

gallbladder, more than 90% of the gallbladder, more than 95% of the gallbladder, or more than 99% of the gallbladder).

DESCRIPTION OF THE DELIVERY MECHANISMS:

[0084] Delivery of the conduit may be accomplished in a variety of ways. An exemplar delivery method is shown in FIG. 18, and a flowchart illustrating the method is shown in FIG. 19. The exemplar delivery method shown in FIG. 18A involves using an endoscope 1810 to place one or more guidance elements 1880 (for example a needle, a guidewire, and/or a guidance catheter) between the access body lumen (e.g. the duodenum, stomach, or jejunum) and the gallbladder 14. In cases where a needle, a guidewire and/or a guidance catheter are used, a guidance catheter may be advanced in the patient's gastrointestinal tract, often but not necessarily within the working channel 1812 of an endoscope 1810, until the distal tip of the guiding catheter is proximal to the desired placement location for the device 1820. A needle may be advanced out of the distal end of the guiding catheter through the wall in the gastrointestinal tract, e.g. at a duodenum 30, continuing through the wall of the gallbladder 14, and into the lumen of the gallbladder 14. As an optional step, bile may be aspirated through the needle or any other guidance element 1880 to reduce the pressure within the gallbladder 14, reducing the risk of bile escaping the gallbladder within the peritoneum. To facilitate this, the guidance element (e.g. needle, guidewire, guidance catheter) may incorporate an aspiration port, either distal or anywhere along a surface or wall. As another optional step, a guidewire may be inserted into the gallbladder lumen through the needle. In cases where a guidewire is used, the needle may be withdrawn once the guidewire has been inserted. When desirable, either the guidance catheter or a separate dilatation catheter, having an inflatable balloon 1885 on the distal portion thereof, may be advanced over the previously introduced needle or guidewire until the balloon 1885 is properly positioned through the wall of the gastrointestinal tract and the wall of the gallbladder 14. Once in the desired position, the dilatation balloon 1885 may be inflated with inflation fluid one or more times to a predetermined size so that the tissue around the puncture site is expanded to accommodate the device 1820. Generally, the inflated diameter of the section of the balloon contacting the wall of the gallbladder 14 and gastrointestinal tract access lumen is slightly smaller than the outer diameter of the tubular portion 1830 of the device 1820 that will be inserted through the puncture. In one approach, the device 1820 may then be guided into position over the guidance element(s) 1880 (e.g. needle, guidewire, guidance catheter) through the hole in the wall of the gastrointestinal tract and the wall of the gallbladder 14 to the desired depth. Once in the desired position, the device 1820 may be deployed and held in position by its retaining features 1822 and the adjacent tissue.

[0085] When the device **1820** is delivered in conjunction with a guidance element **1880** such as a needle, a guidewire, and/or a guidance catheter, the device **1820** may be positioned within a delivery catheter **1816** that constrains the device **1820** in its delivery configuration (**FIG. 18B**). The delivery catheter **1816** may incorporate a separate lumen to accommodate the guidance element **1880**. When the device **1820** is placed in the desired position, the delivery catheter **1816** may be manipulated or repositioned relative to the device **1820** in order to deploy the device **1820** and effect its reconfiguration into the deployed configuration or the final configuration (**FIGS. 18C-E**). Manipulation of the delivery catheter **1816** may, for example, include activation of a deployment device such as a balloon section **1885** (**FIG. 18F**). The balloon profile may have a consistent profile, or it may have a varied profile, such as that shown in **FIG. 18G**. A varied balloon **1885** profile may facilitate tissue approximation (*e.g.* the wall of the gallbladder **14** and the wall of the gastrointestinal tract access lumen such as a duodenum **30**) during dilatation and delivery steps. As described above, it may be desirable for the pilot hole for the guide element **1880** to have a small diameter relative to the size of the conduit device **1820** to be installed, in order to create a better seal between the surfaces and reduce the risk of leaks. Once the guidance element **1880** (*e.g.* a guidewire) is in place, a delivery catheter **1816** may be inserted over the guidance element **1880** and into the gallbladder **14**. The delivery catheter **1816** carries the conduit device **1820** and conduit deployment device, such as a balloon section **1885**, which can be expanded to both dilate the tissue and deploy the conduit **1820** into a deployed or final configuration once it is positioned in the desired location (**FIG. 18G-I**). Once the conduit **1820** has been deployed, the delivery catheter **1816** and any other delivery elements **1880** (*e.g.* needle, guidewire, *etc.*) may then be withdrawn, leaving the conduit **1820** in place. The delivery catheter **1816** may be sized to fit in the working channel **1812** of a typical endoscope **1810**. When resident on or in the delivery catheter **1816** prior to deployment, the conduit device's **1820** outer profile may be similar to that of the delivery catheter **1816**, facilitating insertion and reducing the potential to catch or snag anywhere during delivery. When the conduit **1820** has been placed properly and connects the gallbladder **14** and the access body lumen, the conduit **1820** may be deployed and secured in place.

[0086] Another delivery method is to mount either the conduit **2020** or a holder for the conduit on the distal end of an endoscope **2010**. After navigating to the desired location with the endoscope **2010**, the conduit **2020** may then be inserted through the wall of the access body lumen and the gallbladder **14** to form the desired passageway. This is illustrated in **FIG. 20**.

[0087] For delivery methods that involve the use of a guidewire, the guidewire could be of a traditional design and used according to conventional methods. In this case, a length of guidewire is inserted into the gallbladder **14** through the wall of the gallbladder. An extra length

of guidewire is then inserted and allowed to accumulate within the gallbladder **14**, thus passively retaining the guidewire distal end in the gallbladder **14** while the guidewire is used to deliver additional elements. This type of guidewire has no additional feature that serves to retain the distal end within the gallbladder **14** during treatment: the distal end floats freely in the lumen of the gallbladder **14**, and withdrawal involves simply pulling the guidewire from the proximal end.

[0088] An alternate embodiment of the guidewire **2182** includes a retention feature **2118** to retain the distal end once it has been successfully inserted into the gallbladder **14** lumen. This allows for the guidewire **2182** to be placed under increased tension without the risk of pulling it out of the gallbladder **14** unintentionally. The ability to place the guidewire **2182** under tension may be useful, for instance, when approximating the walls of the access body lumen and the gallbladder **14**, during the insertion of a delivery catheter (not shown), and delivery and/or deployment of a conduit. The feature **2118** on the distal end of a guidewire **2182** that provides for retention may have a number of different shapes, such as a "T" (FIG. 21A), an arrow head (FIG. 21B), a flat spiral (FIG. 21C), a funnel-shaped spiral (FIG. 21D), a folding compliant tag (FIG. 21E), a grappling hook (FIG. 21F), spreading wings (FIG. 21G), or a whale's tail (FIG. 21H). A retention feature may be engaged by first inserting the guidewire **2114** into the gallbladder lumen, then pulling back on the guidewire **2114** until the retention feature engages with the gallbladder wall. The guidewire is typically made of Nitinol, however it may be comprised of any material that is capable of elastically bending with the required radii and supporting the required tension in a thin, small profile.

KITS:

[0089] All of the devices required to deliver and install a conduit may be packaged in a kit. Bundling all devices, tools, components, materials, and accessories needed to perform these procedures into a kit may enhance the usability and convenience of the devices, and also improve the safety of the procedure by encouraging clinicians to use the items believed to result in the best outcomes. The kit may be single-use or reusable, or it may incorporate some disposable single-use elements and some reusable elements. The kit may contain, but is not limited to, the following: implantable and/or non-implantable devices; delivery devices (*e.g.* needles, guidewires, guidance catheters, dilators, *etc.*); balloon inflation/deflation accessories; syringes; fluid flow, temperature, and pressure measurement instruments; scissors; scalpels; clips; ablation catheters; endoscopic tools (*e.g.* lithotripsy devices, snares, graspers, clamps, forceps, *etc.*). The kit may be supplied in a tray, which organizes and retains all items so that they can be quickly identified and used.

DESCRIPTION OF OTHER USES:

[0090] The techniques and devices described in this application may prove beneficial in applications beyond their initial use in the treatment of biliary disease.

[0091] For example, they may prove to be an effective mechanism of treating cholangitis

5 (infection of the common bile duct **18**). This condition is usually bacterial, and occurs when the bile duct is blocked by gallstones **20** or a tumor. Traditional treatment involves the insertion a stent or drainage catheter into the common bile duct **18** to allow bile to drain into the duodenum from locations above the obstruction. Placement of a conduit into the gallbladder **14** may allow for an alternate method of draining bile and/or other fluids into the duodenum. Any blockage in
10 the common bile duct **18** between the entrance of the cystic duct and the duodenum may be treated in this way. See **FIG. 2**.

[0092] Another use of the devices and techniques described elsewhere in this application may be to create anastomoses between any body lumens in proximity to one another. This may include, but is not limited to: small bowel to small bowel anastomoses, small bowel to large bowel
15 anastomoses, large bowel to large bowel anastomoses, and stomach to small bowel anastomoses. Additionally, creating a conduit between the stomach and other body lumens may be useful and effective for treating and/or managing obesity.

[0093] Another use of the devices and techniques described herein is for drainage of any body lumen into another body lumen in proximity, for example, the drainage of pancreatic
20 pseudocysts.

[0094] While preferred embodiments of the present invention have been shown and described herein, it will be obvious to those skilled in the art that such embodiments are provided by way of example only. Numerous variations, changes, and substitutions will now occur to those skilled in the art without departing from the invention. It should be understood that various
25 alternatives to the embodiments of the invention described herein may be employed in practicing the invention. It is intended that the following claims define the scope of the invention and that methods and structures within the scope of these claims and their equivalents be covered thereby.

WHAT IS CLAIMED:

1. A device for treating biliary disease comprising: a component configured for deployment between a gallbladder and a location within a gastrointestinal tract of a patient, the component having a proximal end and a distal end and a lumen extending therethrough.
5
2. The device of claim 1 wherein the device is configured for deployment by at least one of an endoscope, a needle, a guidewire, a guidance catheter, and a dilatation catheter.
3. A system for treating biliary disease comprising a device for configuring a duct between a gallbladder and a gastrointestinal tract of a patient having a proximal end and a distal end with a lumen extending therethrough between.
10
4. The system of claim 3 further comprising a delivery mechanism for delivering a substance.
5. The system of claim 3 or claim 4 further comprising at least one of an endoscope, a needle, a guidewire, a guidance catheter, and a dilatation catheter.
6. The system of claim 5 wherein the endoscope further comprises an ultrasound device.
15
7. The system or device of any one of the preceding claims wherein deployment causes a conduit to be formed between a gallbladder lumen and a target location within the gastrointestinal tract.
8. A biliary disease treatment device comprising: an implant adapted to be delivered by an endoscope to a gastrointestinal site in proximity to a gallbladder, and further adapted to form a conduit between the gastrointestinal site and the gallbladder.
20
9. The device of claim 8 wherein the conduit is formed between a lumen of the gallbladder and a target location within the gastrointestinal tract.
10. The system or device of claim 7 or claim 9 wherein the target location within the gastrointestinal tract is proximal to a duodenum.
25
11. The system or device of any one of the preceding claims wherein the device is formed from a bioresorbable material.

12. The system or device of any one of the preceding claims wherein the device is removable.

13. The system or device of any one of the preceding claims wherein the device is expandable.

5 14. The system or device of any one of the preceding claims wherein the device is configurable in one or more configurations selected from a deployment configuration, a delivery configuration and a final configuration.

15. The system or device of claim 14 wherein a profile of the device changes between said configurations.

10 16. The system or device of any one of the preceding claims wherein a cross-sectional area of the device is variable along a length.

17. The system or device of any one of the preceding claims wherein the component or implant has a flareable end.

15 18. The system or device of claim 17 wherein the flareable end is generally hemispherical.

19. The system or device of any one of the preceding claims wherein the component or implant comprises a configurable retainable feature.

20. The system or device of any one of the preceding claims wherein the component or implant comprises one or more clips configured to secure it at one or more positions.

20 21. The system or device of any one of the preceding claims wherein the component or implant comprises one or more fenestrations.

22. The system or device of any one of the preceding claims wherein the lumen or conduit is configurable to provide restrictable fluid flow.

25 23. The system or device of any one of the preceding claims further comprising a valve.

24. The system or device of claim 23 wherein the valve is at least one of a flow-restrictor or one-way valve.

25. The system or device of any one of the preceding claims wherein the device is flexible.

26. The system or device of any one of the preceding claims wherein the component or implant includes a generally elongate tube that is adapted and configured to extend into the gastrointestinal tract.

27. The system or device of claim 26 wherein the tube is patent at a first end.

28. The system or device of claim 27 wherein the patent first end is for placement adjacent the gallbladder.

29. The system or device of any one of claims 26 to 28 wherein the tube is not patent at a second end.

30. The system or device of any one of claims 26 to 29 wherein the tube has an adjustable length.

31. The system or device of any one of claims 1 to 22 further comprising one or more fluid control components.

32. The system or device of any one of the preceding claims further comprising an enlargeable portion comprising two or more legs.

33. A kit for treating biliary disease comprising a duct forming component positioned between a gallbladder and a gastrointestinal tract.

34. A kit for treating biliary disease comprising the system or device of any one of claims 1 to 32.

35. The kit of claim 33 or claim 34 further comprising a compound for delivery to a tissue.

36. The kit of any one of claims 33 to 35 further comprising a catheter.

37. The kit of any one of claims 33 to 36 further comprising a guidance element.

38. The kit of any one of claims 33 to 37 further comprising an ablation device.

39. The kit of any one of claims 33 to 38 wherein the compound comprises a sclerosing agent.

40. The kit of any one of claims **33** to **38** wherein the compound comprises antibiotics.

41. The kit of any one of claims **33** to **38** wherein the compound comprises inflammatory agents.

5 42. The kit of any one of claims **33** to **41** further comprising one or more biocompatible gels and biocompatible foams.

43. The kit of any one of claims **33** to **42** further comprising one or more of a pair of scissors, a scalpel, a swab, a syringe, a hemostat, a lubricant, a needle, a snare, an antiseptic, and an anesthetic.

10 44. A method for treating biliary disease comprising: (a) creating a duct or fistula between a gallbladder lumen and a portion of a gastrointestinal tract; and (b) providing for drainage from the gallbladder to the gastrointestinal tract.

45. The method of claim **44** further comprising the step of delivering a substance to the gallbladder via the duct.

15 46. The method of claim **44** or claim **45** further comprising the step of delivering a device to the gallbladder through the duct.

47. The method of claim **46** wherein the delivered device is one or more of a stent, a drug-coated stent, and a catheter.

20 48. The method of any one of claims **44** to **47** wherein the step of creating the duct further comprises the step of inserting a device in communication between the gastrointestinal tract and the gallbladder lumen.

49. The method of any one of claims **44** to **47** wherein the step of creating the duct between a gallbladder lumen and a portion of a gastrointestinal tract comprises the step of inserting a conduit between the gallbladder lumen and the portion of the biliary system.

25 50. The method of claim **49** further comprising the step of forming a biological duct in situ from a patient's tissue.

51. The method of claim **50** wherein the step of inserting a conduit between the gallbladder lumen and the portion of the gallbladder tract occurs at a first time and the step of

forming the biological duct in situ from the patient's tissue occurs at a second time remote from the first time.

52. The method of any one of claims **44** to **51** further comprising the step of providing a seal to prevent fluid from leaking into a peritoneum.

5 53. The method of claim **44** further comprising the step of defunctionalizing the gallbladder in situ.

54. The method of claim **53** wherein the step of defunctionalizing is achieved by delivering a substance into a space within the gallbladder.

10 55. The method of claim **54** wherein the delivered substance is selected from the group consisting of gel and foam.

56. The method of claim **54** or claim **55** further comprising the step of activating the delivered substance in situ.

57. The method of any one of claims **54** to **56** further comprising delivering an amount of substance sufficient to fill or substantially fill the gallbladder lumen.

15 58. The method of claim **53** wherein the step of defunctionalizing is achieved by one or more of sclerosing or necrotizing a tissue within the gallbladder.

59. The method of claim **58** wherein the step of sclerosing or necrotizing can be achieved by an ablation technique.

20 60. A method of delivering a device to treat biliary disease comprising: (a) using an endoscope to place a guidance element between an access lumen in a body and a gallbladder; (b) inserting a delivery catheter over the guidance element and into the gallbladder; (c) delivering a conduit on the catheter; and (d) positioning the conduit between the access lumen in the body and the gallbladder to create a lumen therebetween.

25 61. The method of claim **60** further comprising the step of forming a biological duct in situ from a patient's tissue.

62. The method of claim **61** wherein the step of positioning the conduit occurs at a first time and the step of forming the biological duct in situ from the patient's tissue occurs at a second time remote from the first time.

63. The method of claim **60** further comprising the step of passively retaining a distal end of the guidance element in the gallbladder while the guidance element is used to deliver additional elements.

64. The method of claim **60** further comprising the step of retaining a distal end of the
5 guidance element within the gallbladder.

65. The method of any one of claims **60** to **64** further comprising the step of removing gallstones through the created lumen.

66. The method of any one of claims **60** to **65** further comprising the step of delivering a substance to the gallbladder via the created lumen.

10 67. The method of claim **45** or claim **66** wherein the substance occupies the gallbladder lumen.

68. The method of any one of claims **45**, **66** and **67** wherein the substances are one or more of antibiotics, inflammatory agents, and anti-inflammatory agents.

15 69. The method of any one of claims **44** to **68** further comprising the step of preventing bile from entering a peritoneum or a gallbladder lumen.

70. The method of any one of claims **44** to **69** further comprising the step of localizing the gallbladder via endoscopic ultrasound.

71. The method of any one of claims **44** to **70** further comprising the step of accessing the gallbladder via the gastrointestinal tract.

20 72. The method of claim **71** wherein the step of accessing is performed in the gastrointestinal tract at a duodenum.

73. The method of any one of claims **44** to **72** further comprising the step of removing gallstones.

25 74. The method of any one of claims **44** to **72** further comprising the step of altering gallstones.

75. The method of claim **74** further comprising the step of removing the altered gallstones.

76. The method of any one of claims **44** to **75** further comprising the step of clearing obstructions within the biliary system.

77. The method of claim **60** wherein the delivered conduit is one or more of a stent, and a drug-coated stent.

5 78. The method of any one of claims **44** to **77** wherein the biliary disease is treated without removal of the gallbladder.

79. The method of any one of claims **44** to **78** further comprising the step of visualizing a treatment area.

10 80. The method of any one of claims **44** to **79** further comprising the step of anchoring the conduit in place.

81. The method of any one of claims **44** to **80** further comprising the step of changing the conduit from a delivery configuration to a deployment configuration.

82. The method of any one of claims **44** to **80** further comprising the step of changing the conduit from a delivery configuration to a final configuration.

15 83. The method of any one of claims **44** to **80** further comprising the step of changing the conduit from a deployment configuration to a final configuration.

84. The method of any one of claims **44** to **83** further comprising the step of reducing a cross-sectional profile of the conduit.

20 85. The method of any one of claims **44** to **84** further comprising the step of providing a seal to prevent fluid from leaking into a peritoneum.

86. The method of any one of claims **44** to **85** further comprising the step of restricting fluid flow from the gallbladder lumen to the gastrointestinal tract.

87. The method of claim **86** further comprising the step of operating a valve to restrict fluid flow.

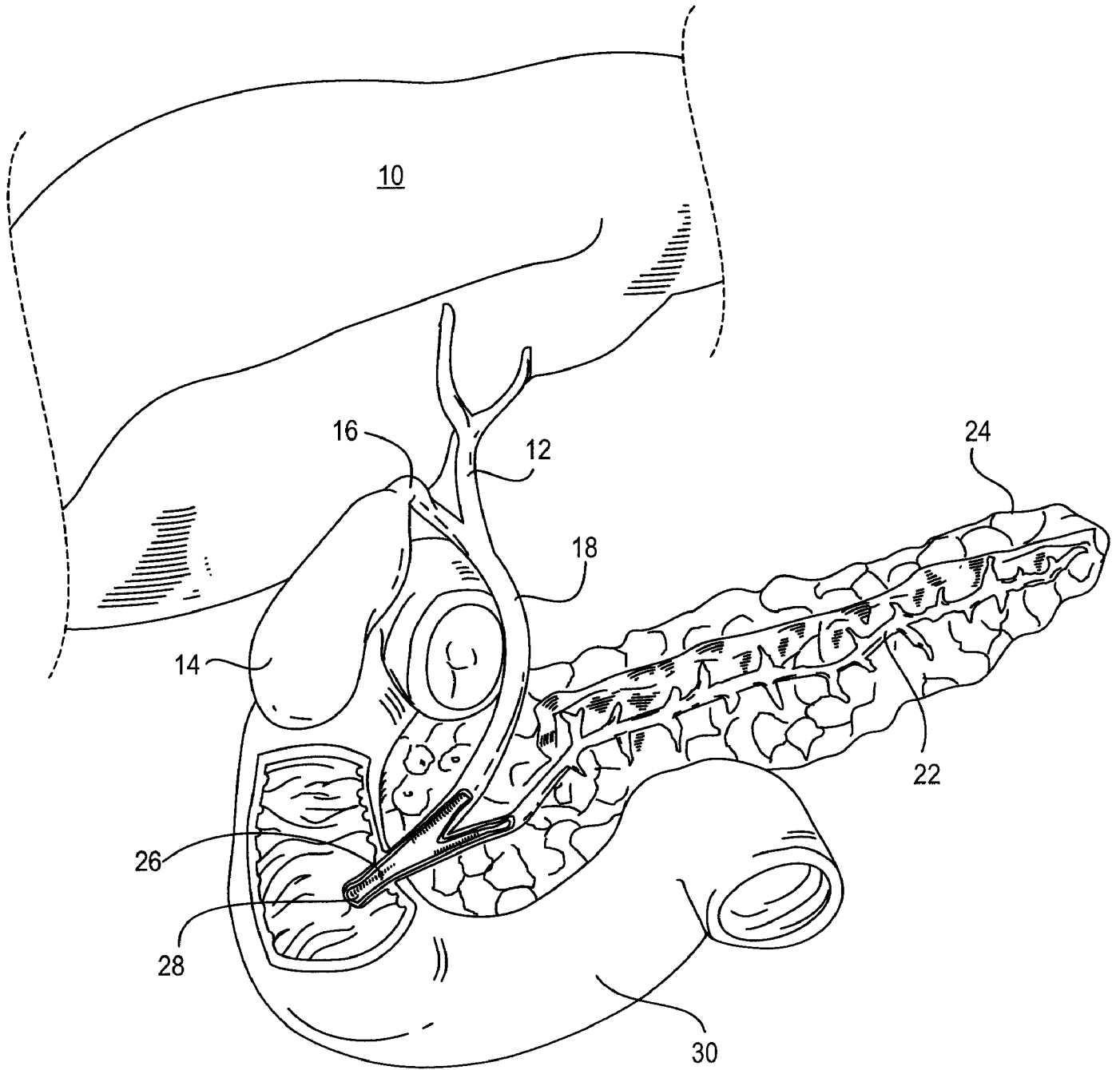

FIG. 1

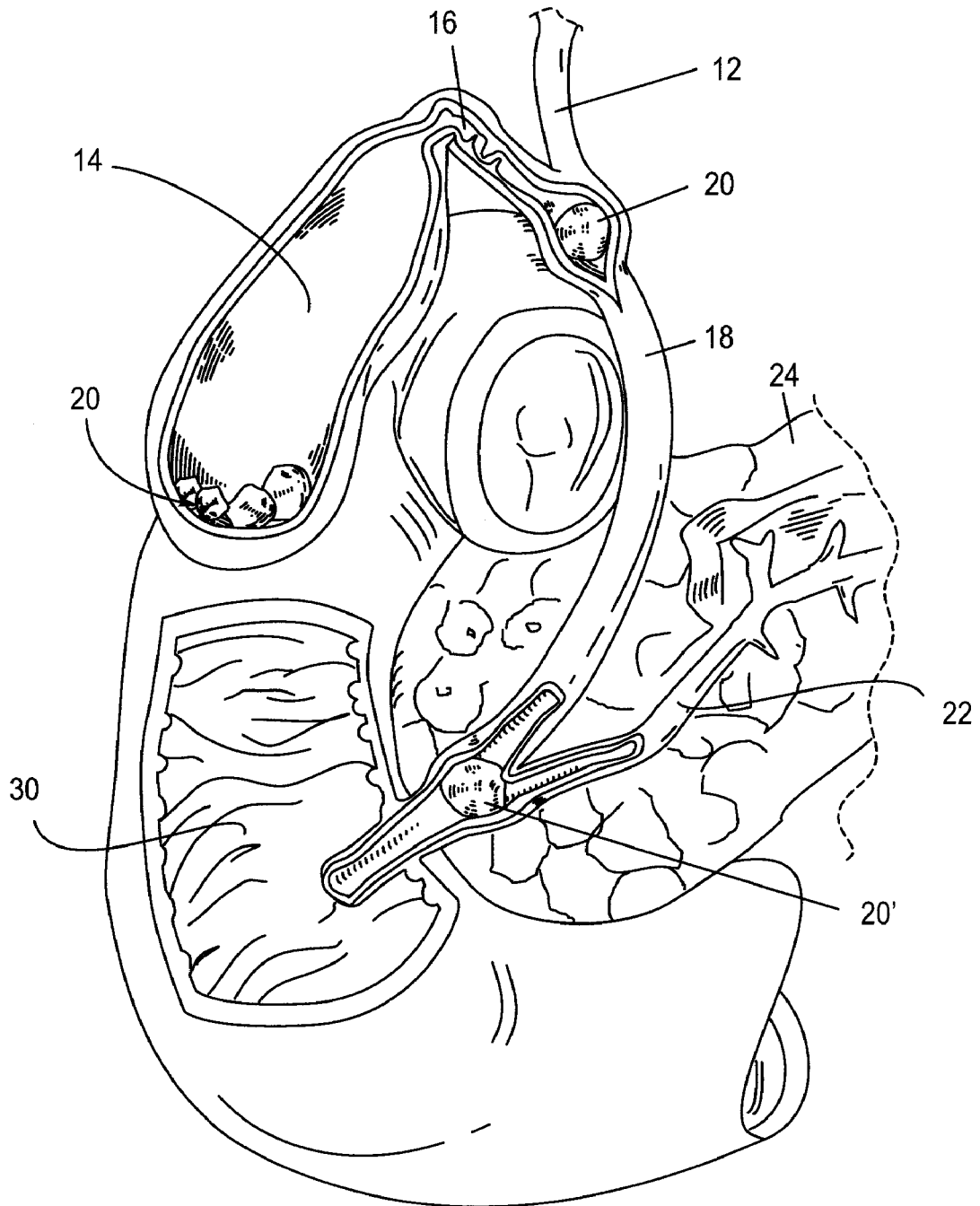

FIG. 2

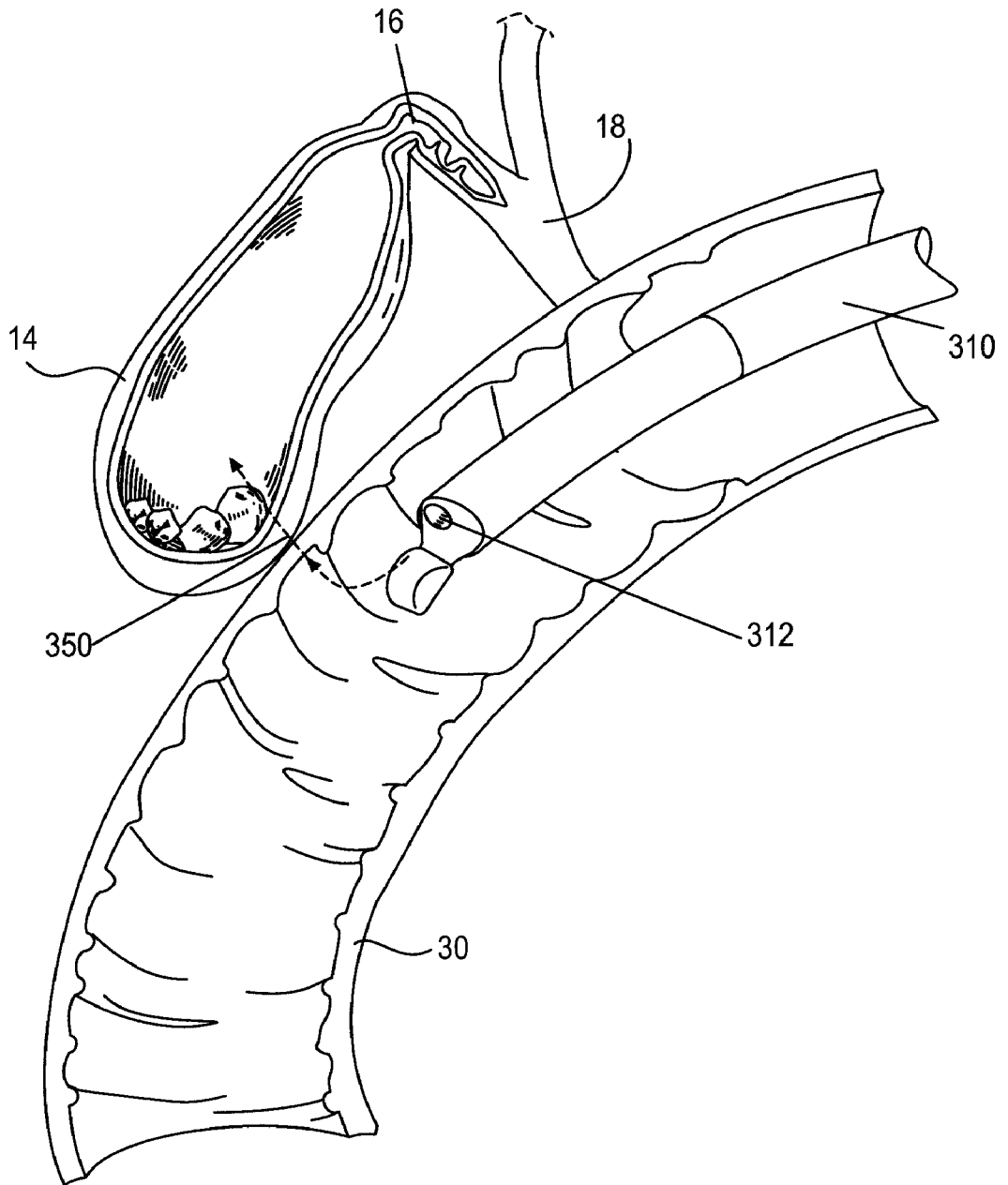

FIG. 3

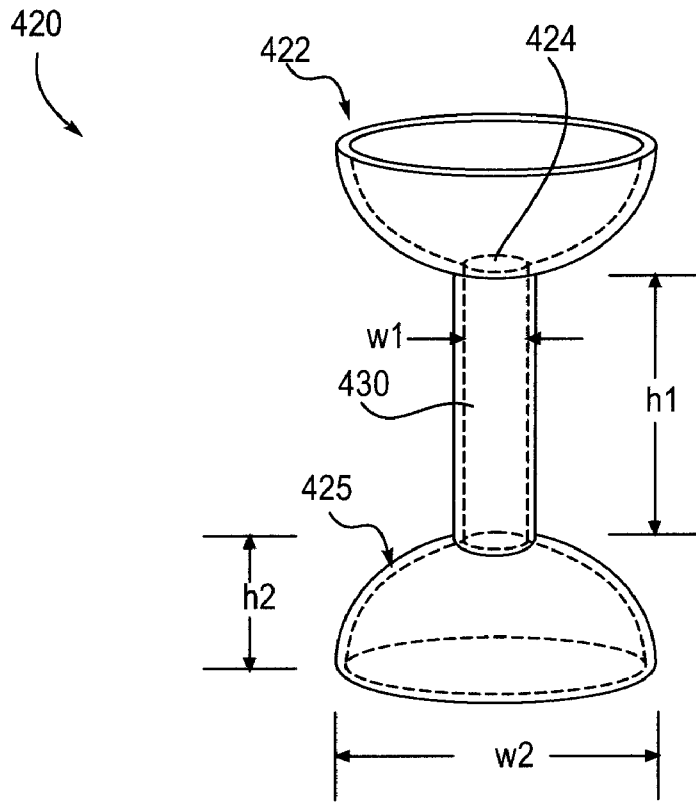

FIG. 4A

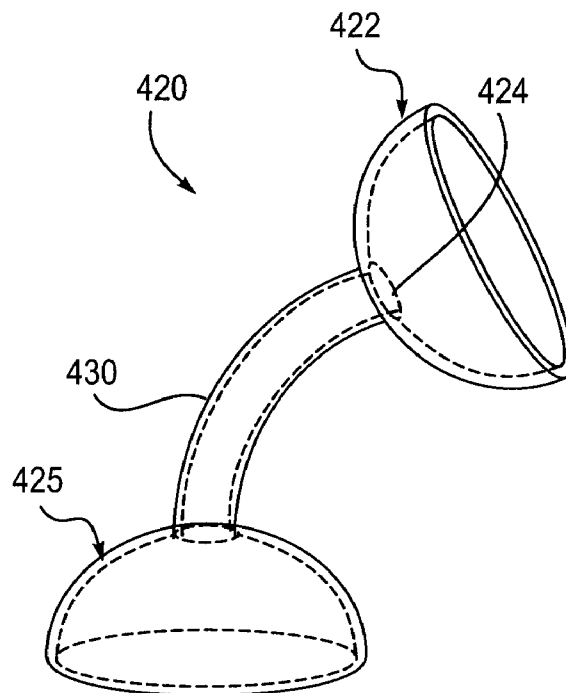

FIG. 4B

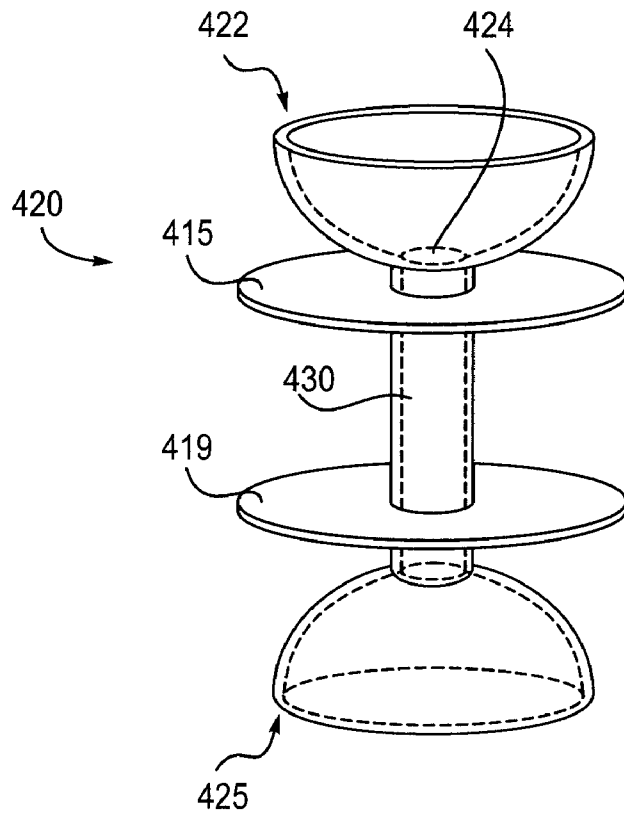

FIG. 4C

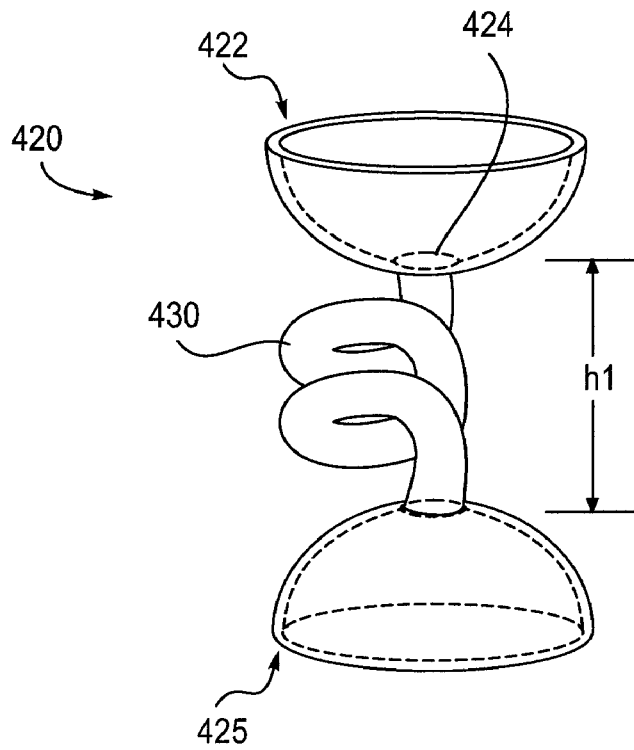

FIG. 4D

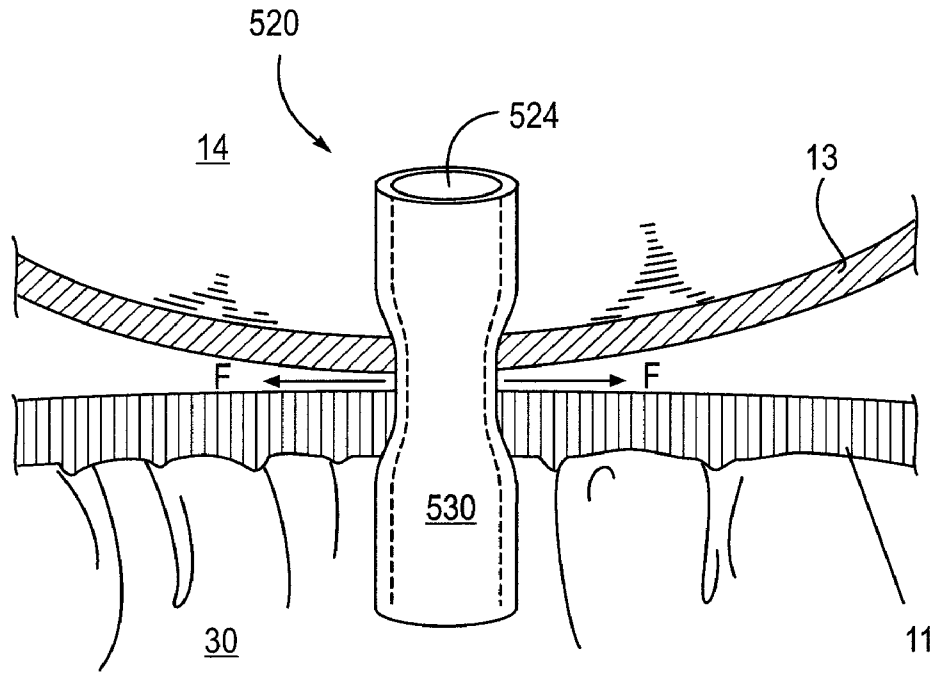

FIG. 5A

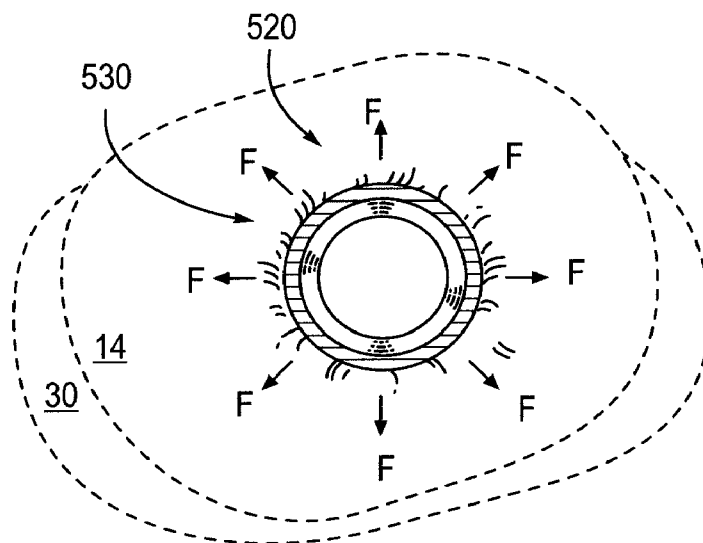

FIG. 5B

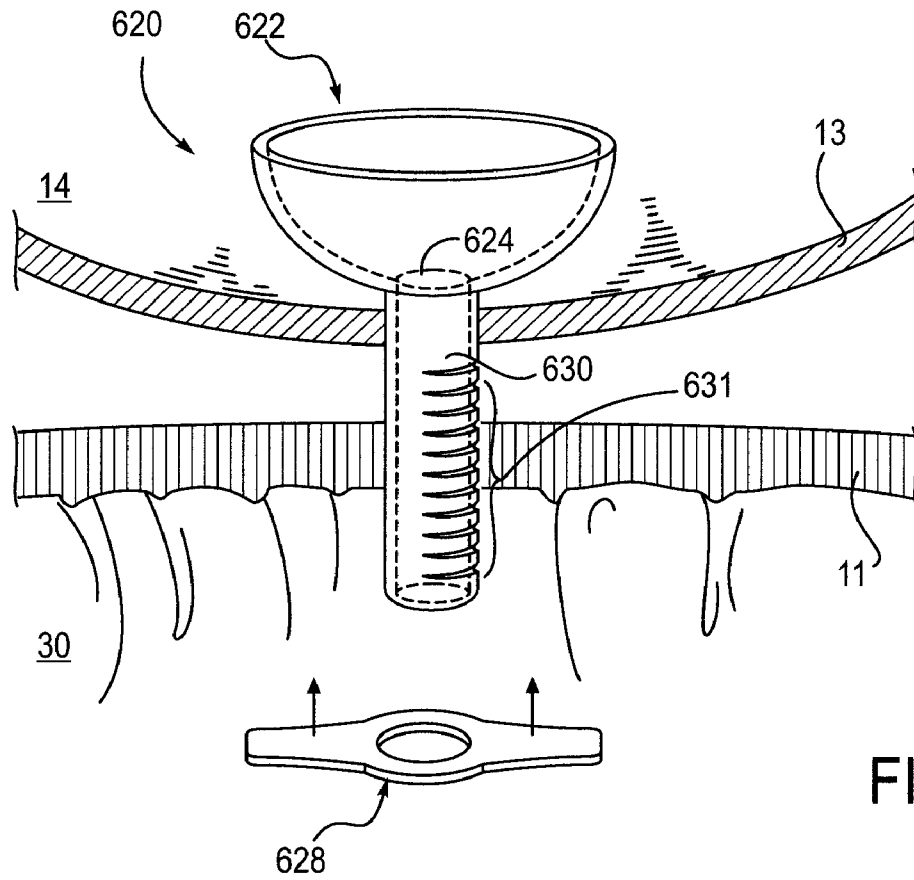

FIG. 6A

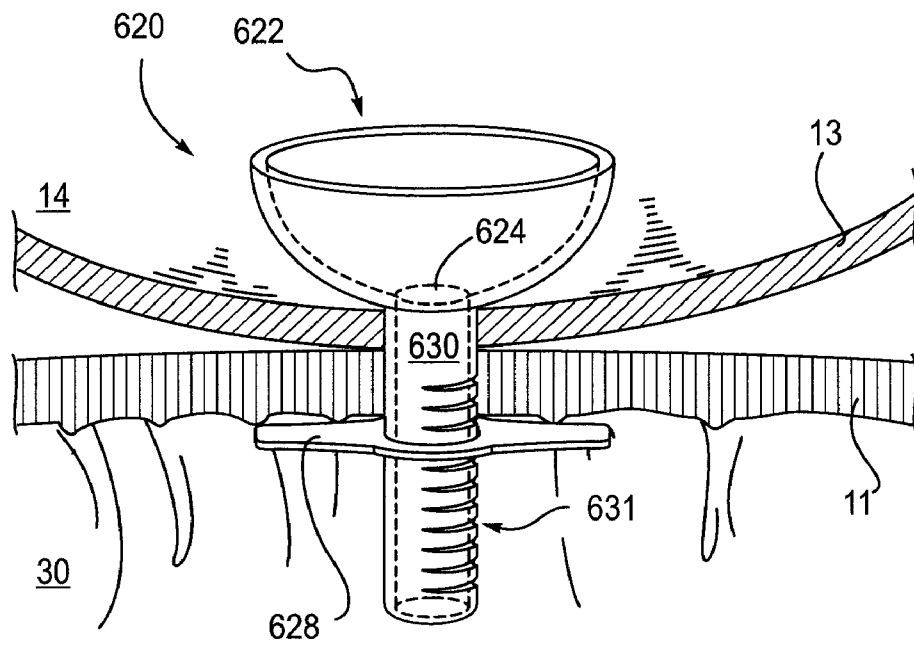

FIG. 6B

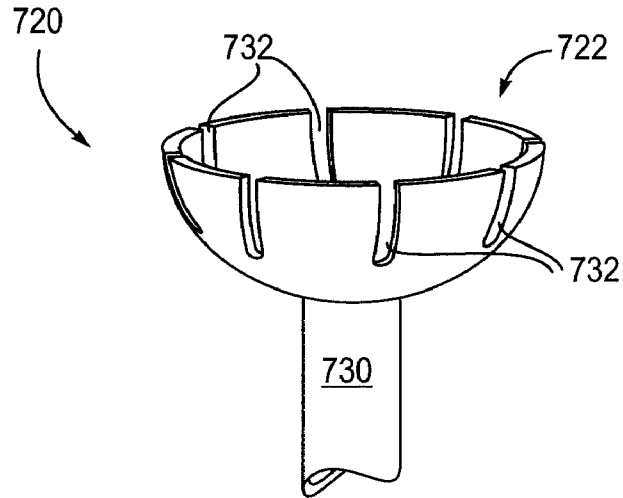

FIG. 7A

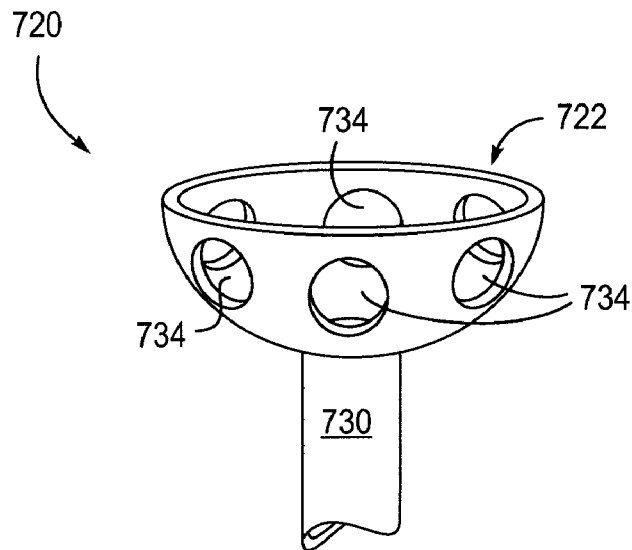

FIG. 7B

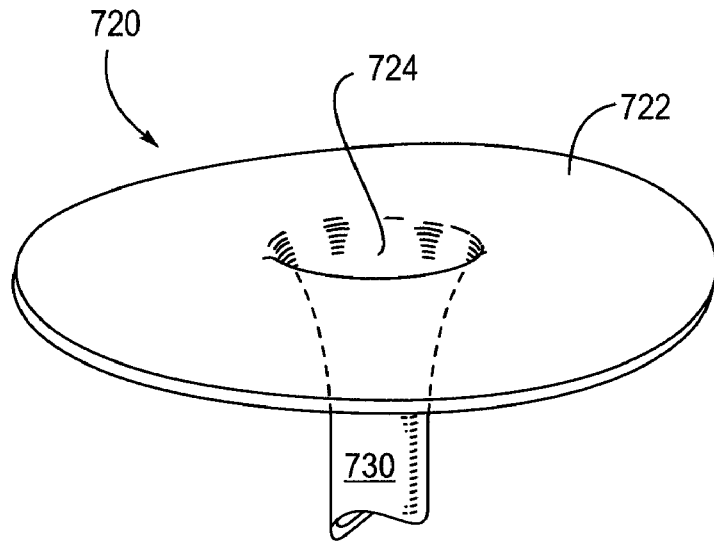

FIG. 7C(1)

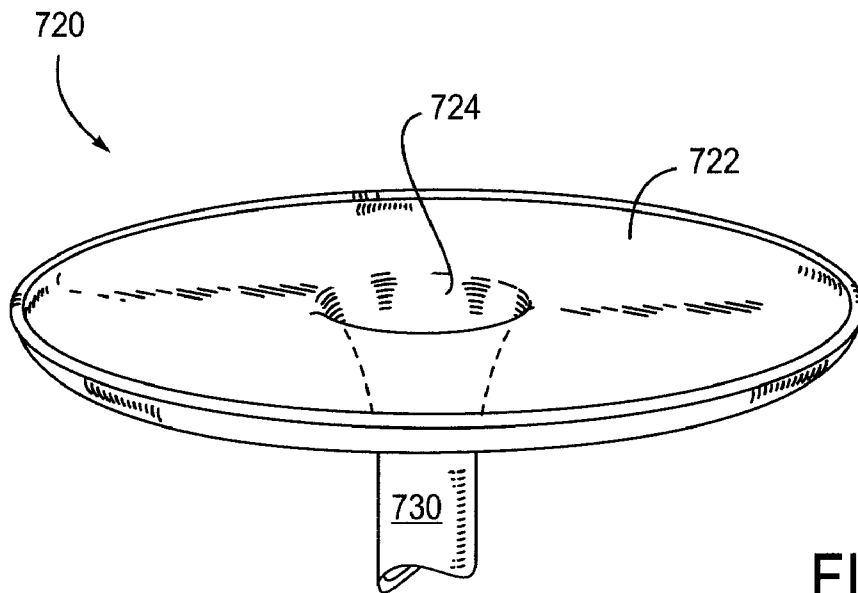

FIG. 7C(2)

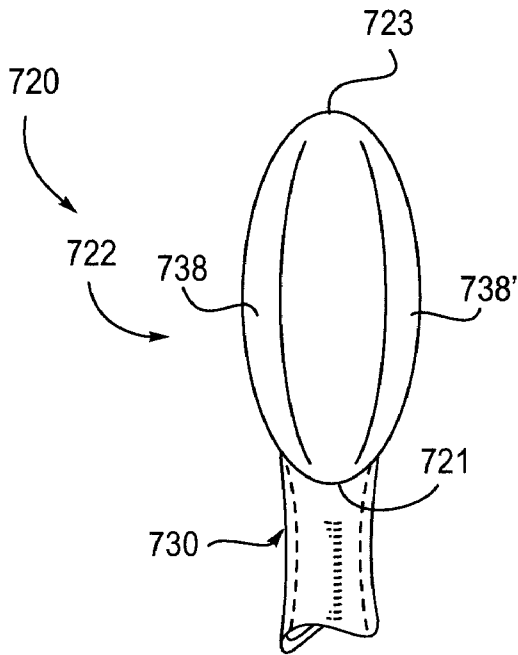

FIG. 7D(1)

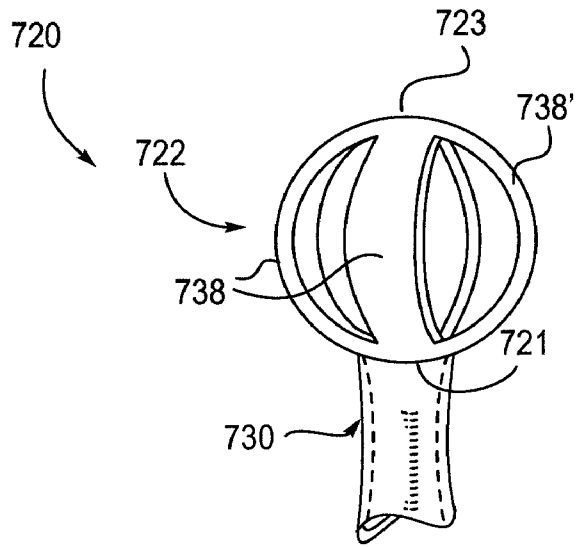

FIG. 7D(2)

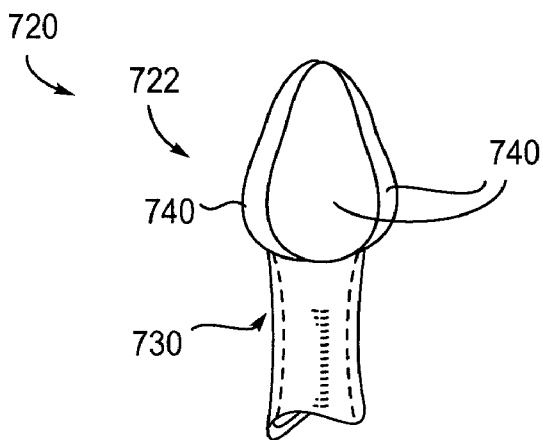

FIG. 7E(1)

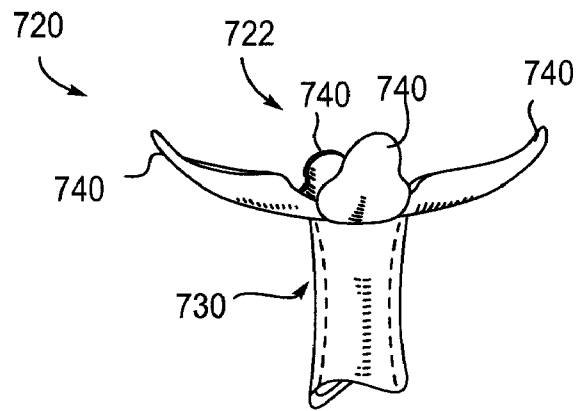

FIG. 7E(2)

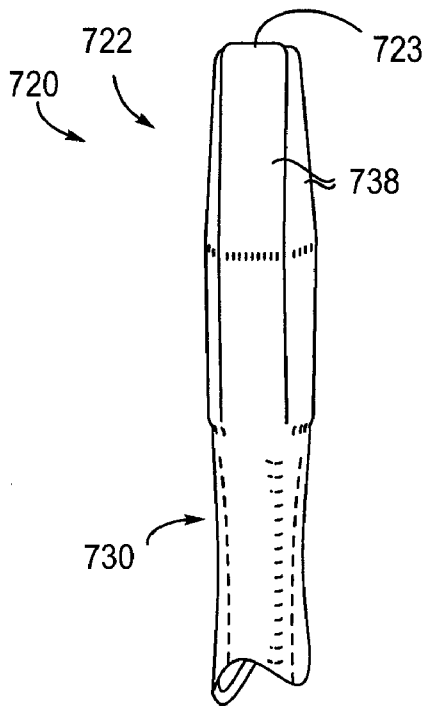

FIG. 7F(1)

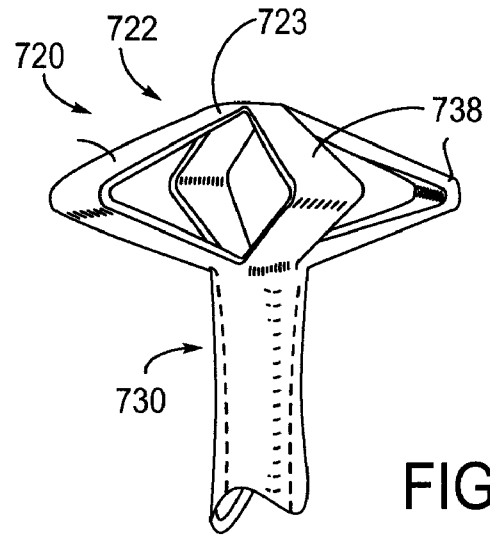

FIG. 7F(2)

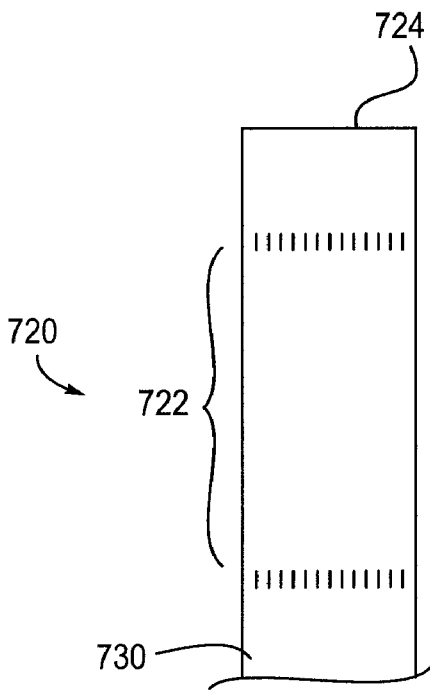

FIG. 7G(1)

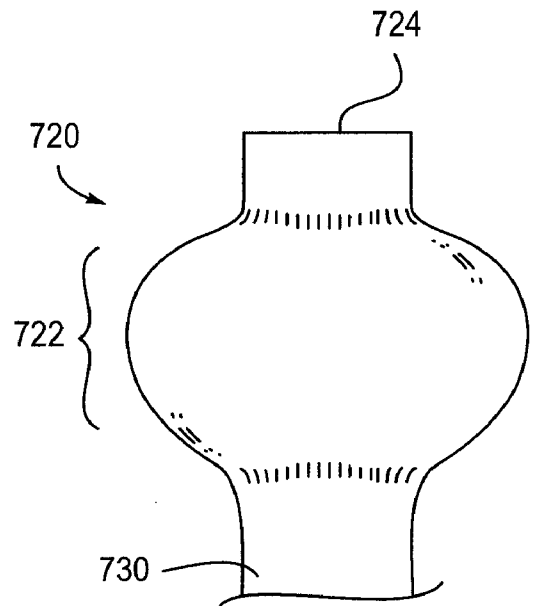

FIG. 7G(2)

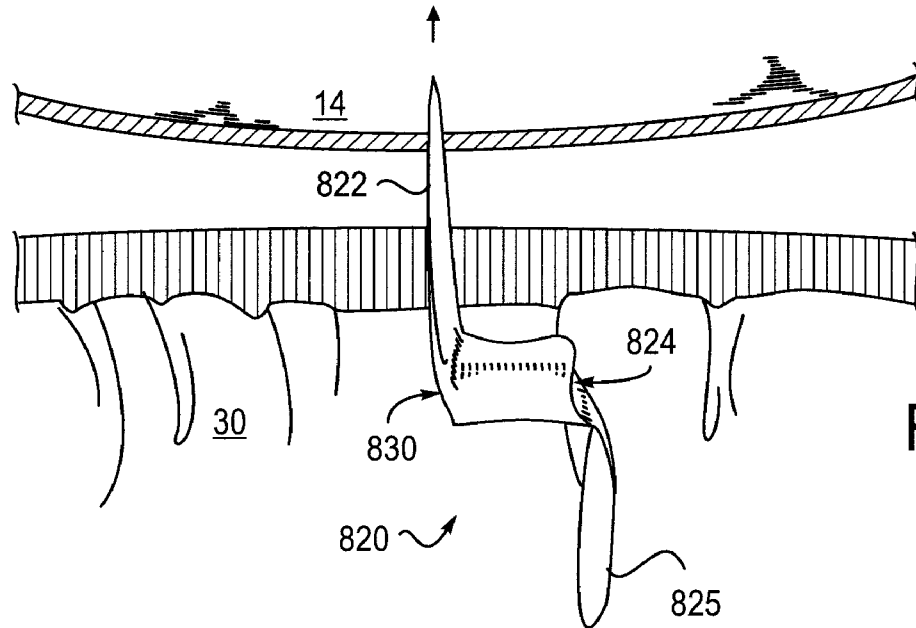

FIG. 8A(1)

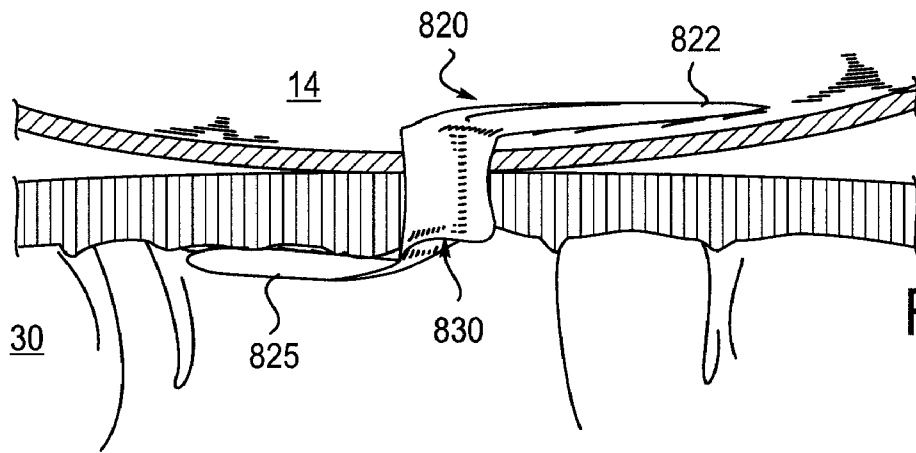

FIG. 8A(2)

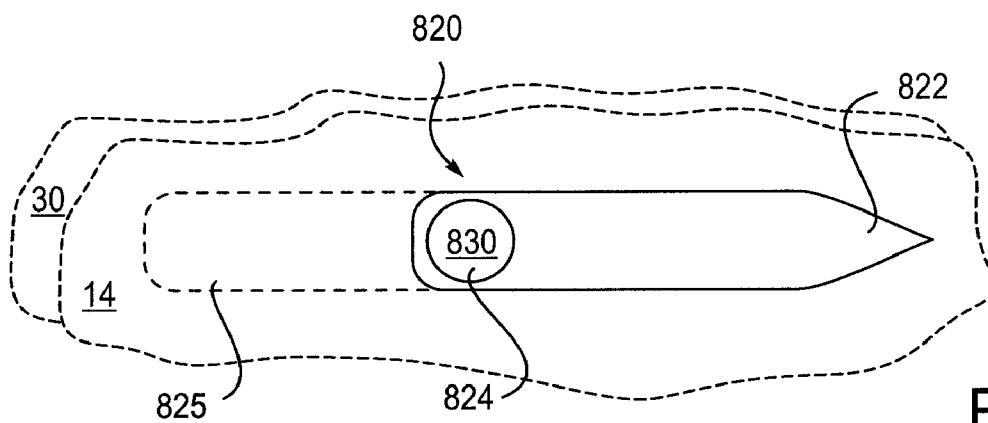

FIG. 8A(3)

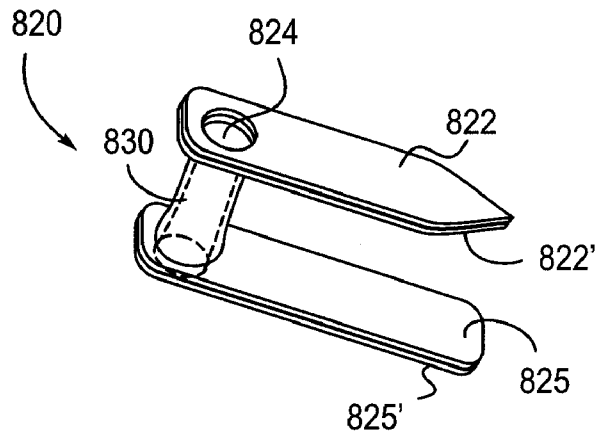

FIG. 8B(1)

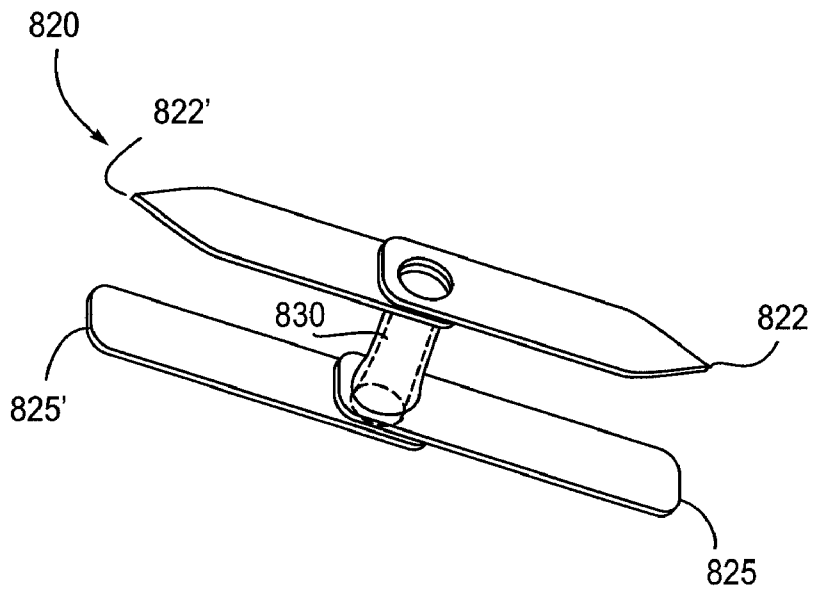

FIG. 8B(2)

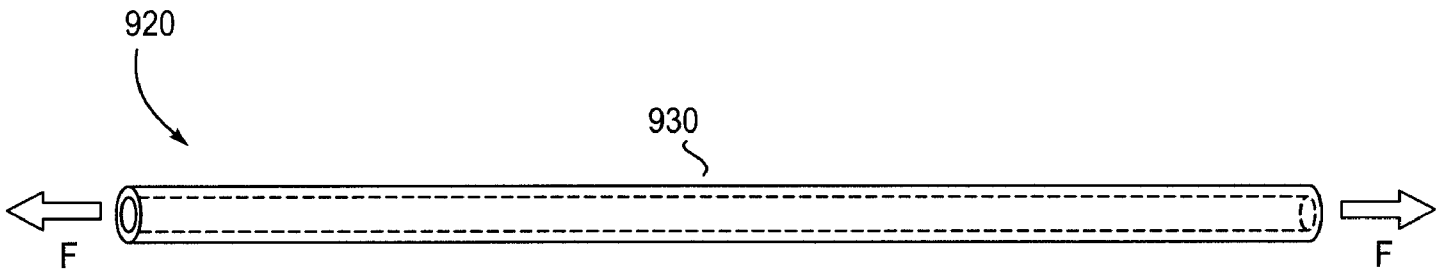

FIG. 9A(1)

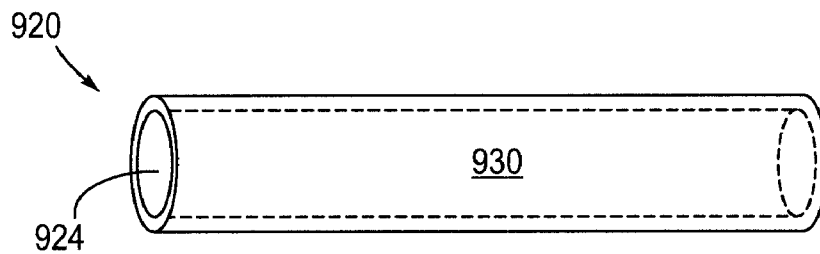

FIG. 9A(2)

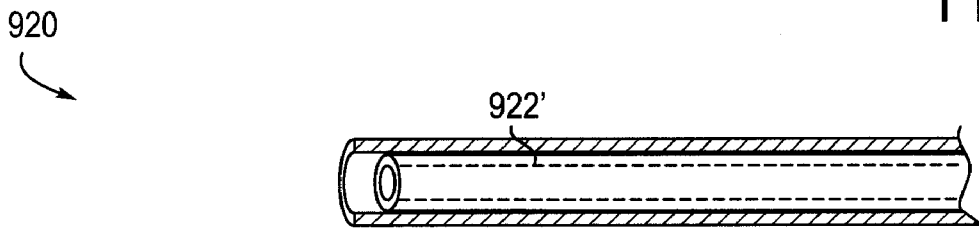

FIG. 9A(3)

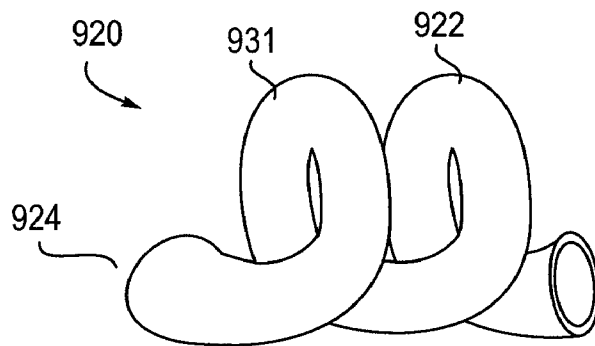

FIG. 9B

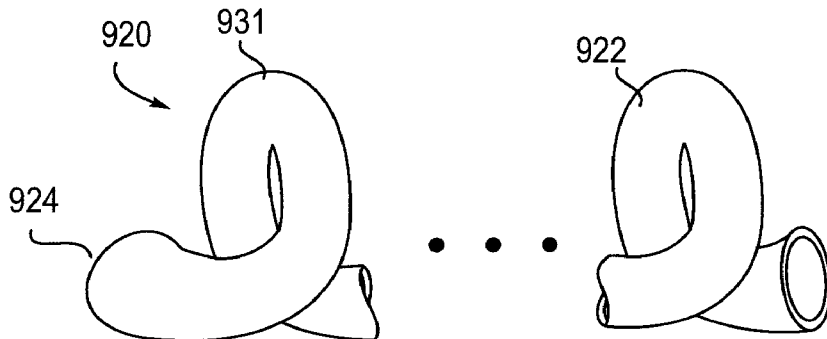

FIG. 9C

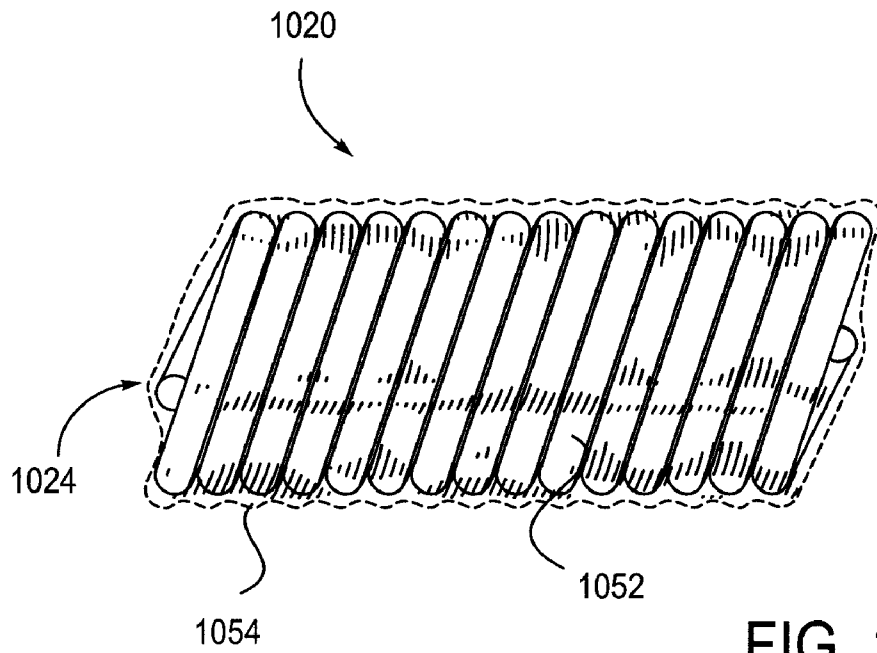

FIG. 10A

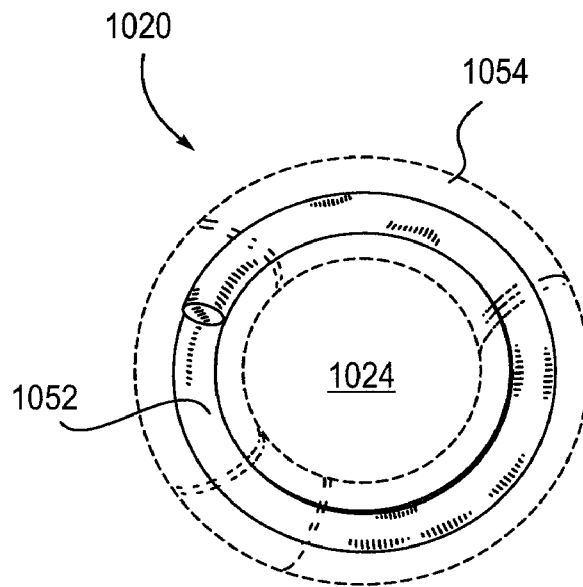

FIG. 10B

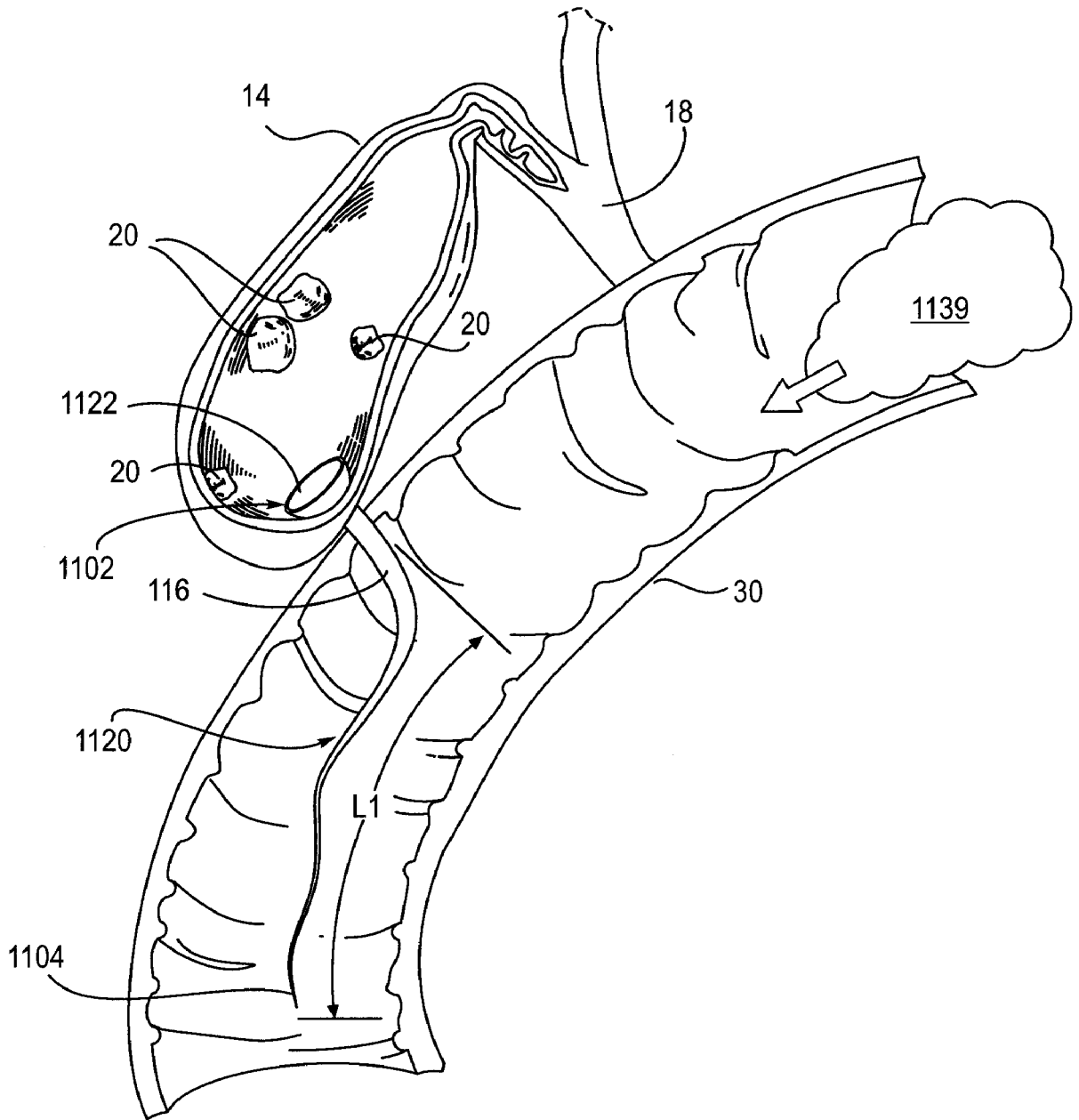

FIG. 11

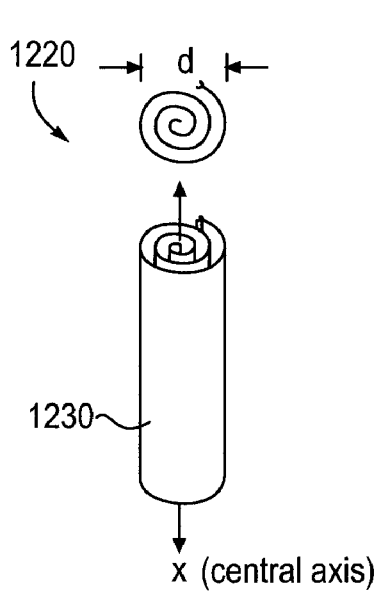

FIG. 12A(1)

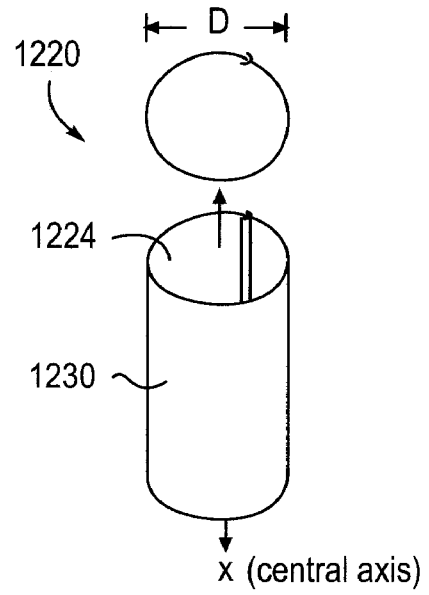

FIG. 12A(2)

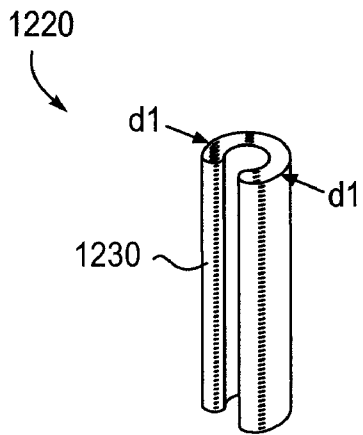

FIG. 12B(1)

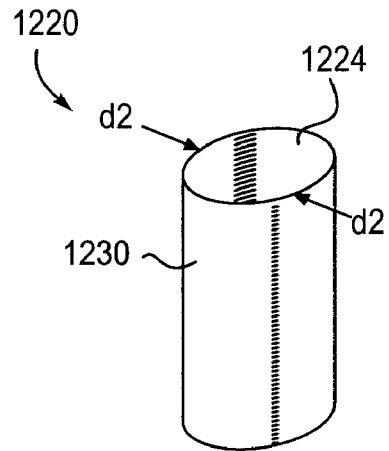

FIG. 12B(2)

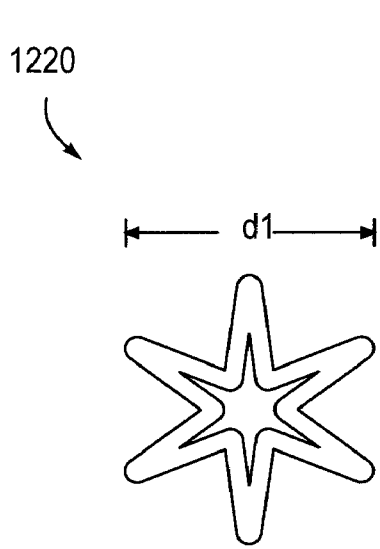

FIG. 12C(1)

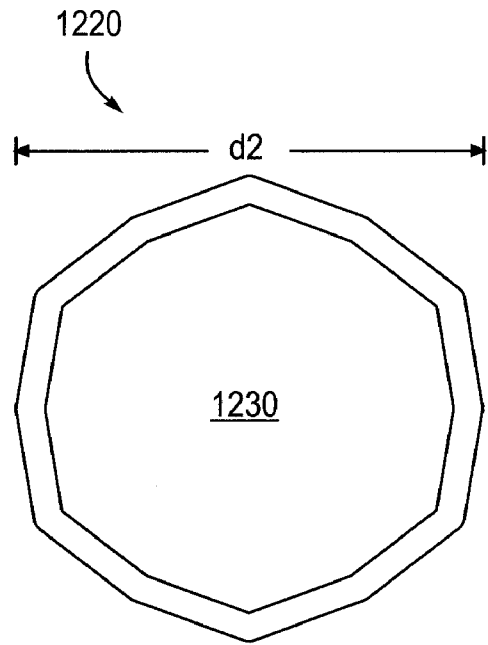

FIG. 12C(2)

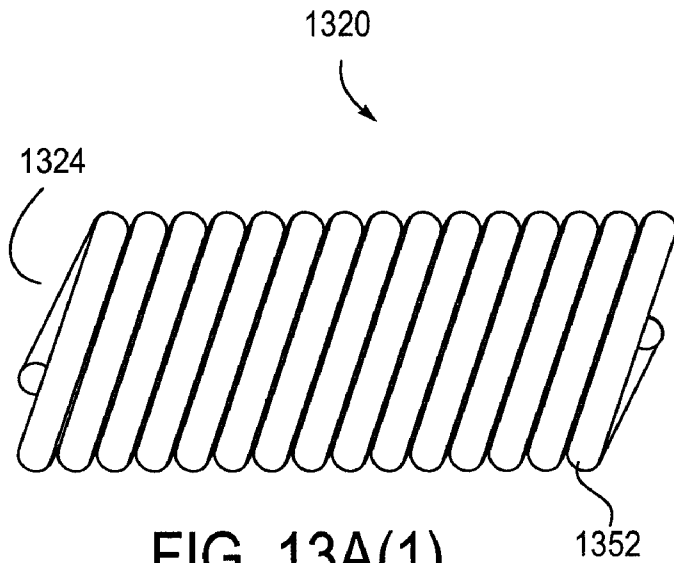

FIG. 13A(1)

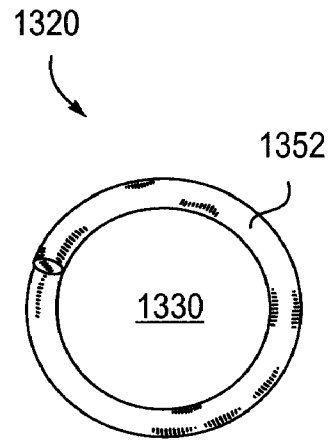

FIG. 13A(2)

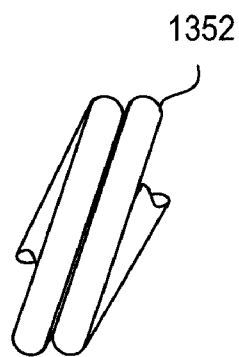

FIG. 13B(1)

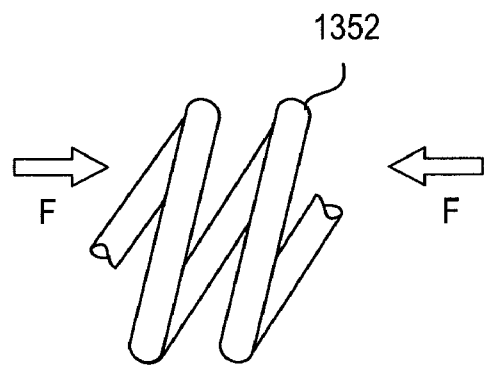

FIG. 13B(2)

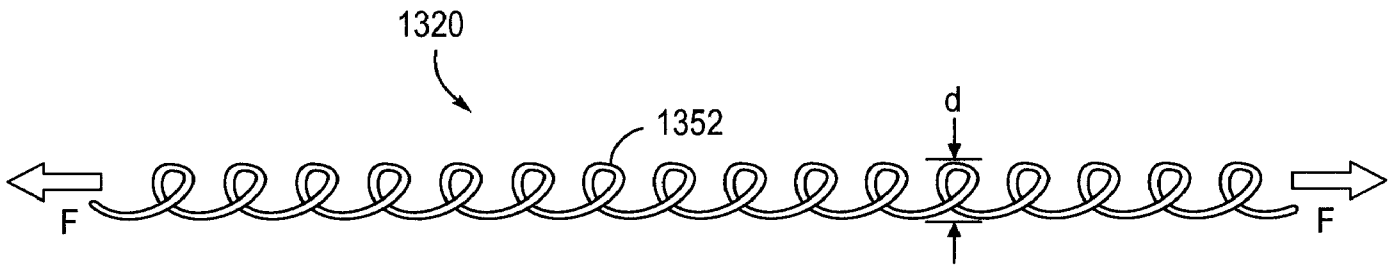

FIG. 13C(1)

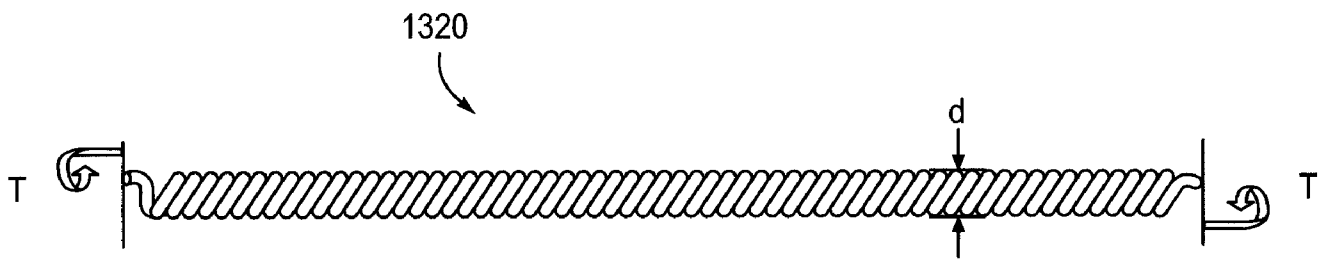

FIG. 13C(2)

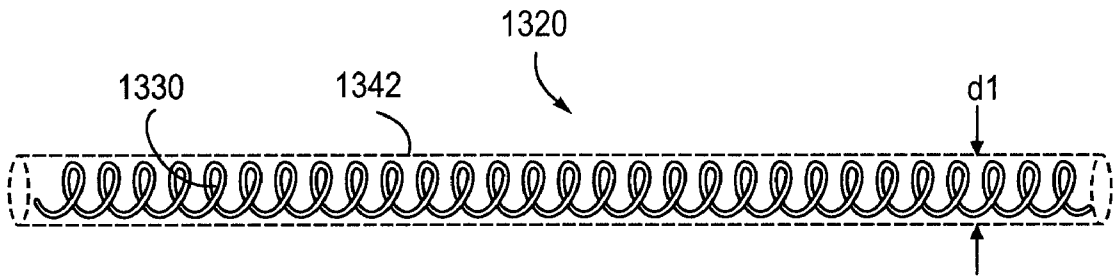

FIG. 13D

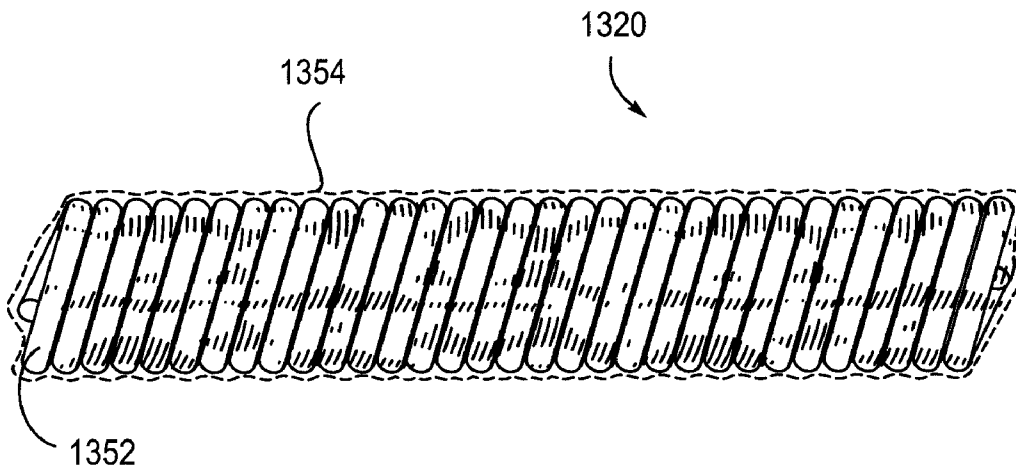

FIG. 13E(1)

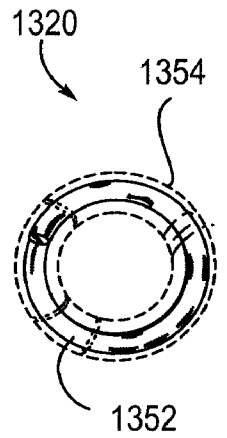

FIG. 13E(2)

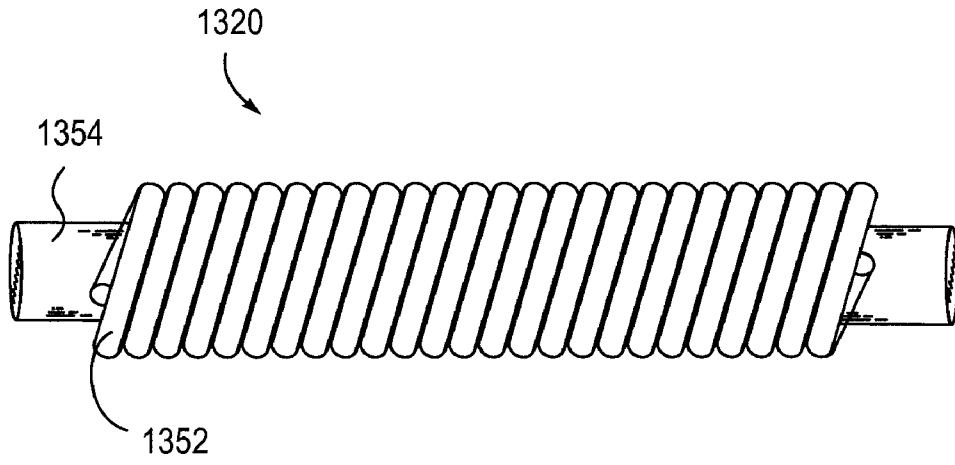

FIG. 13F

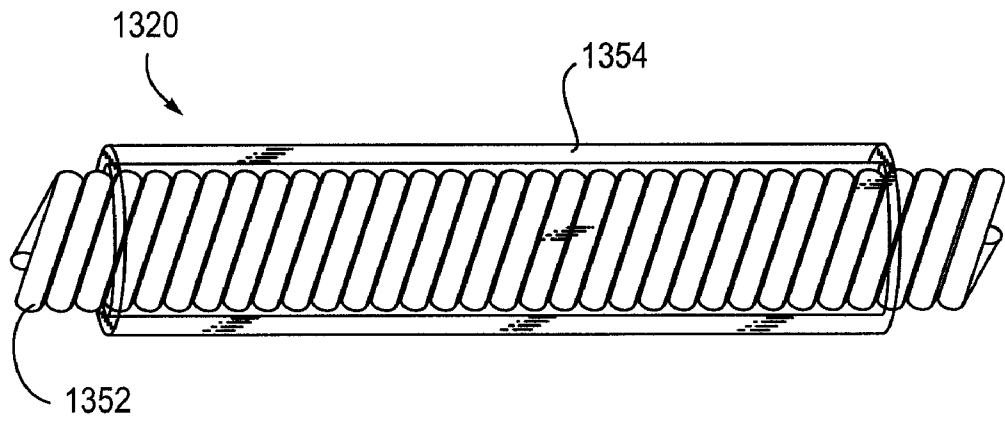

FIG. 13G

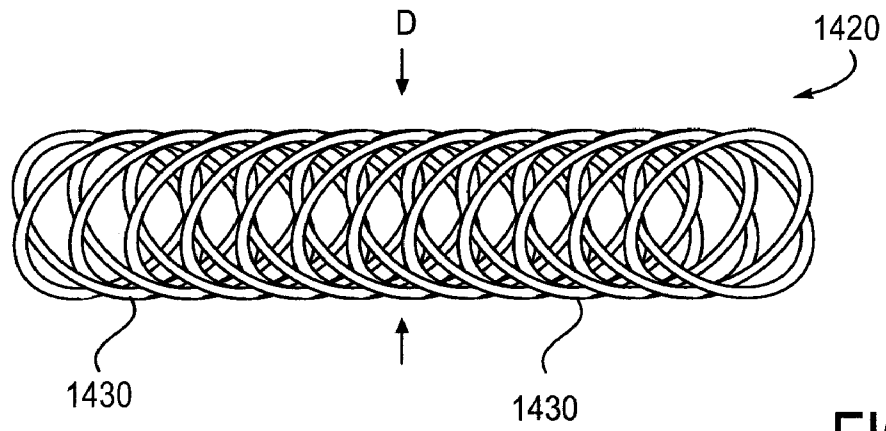

FIG. 14A

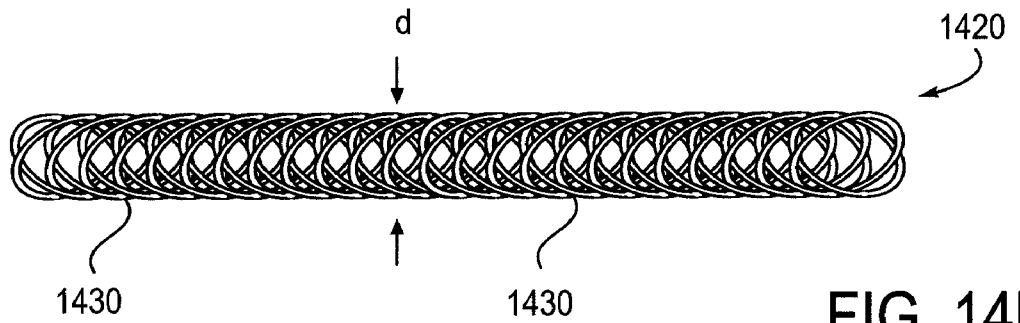

FIG. 14B

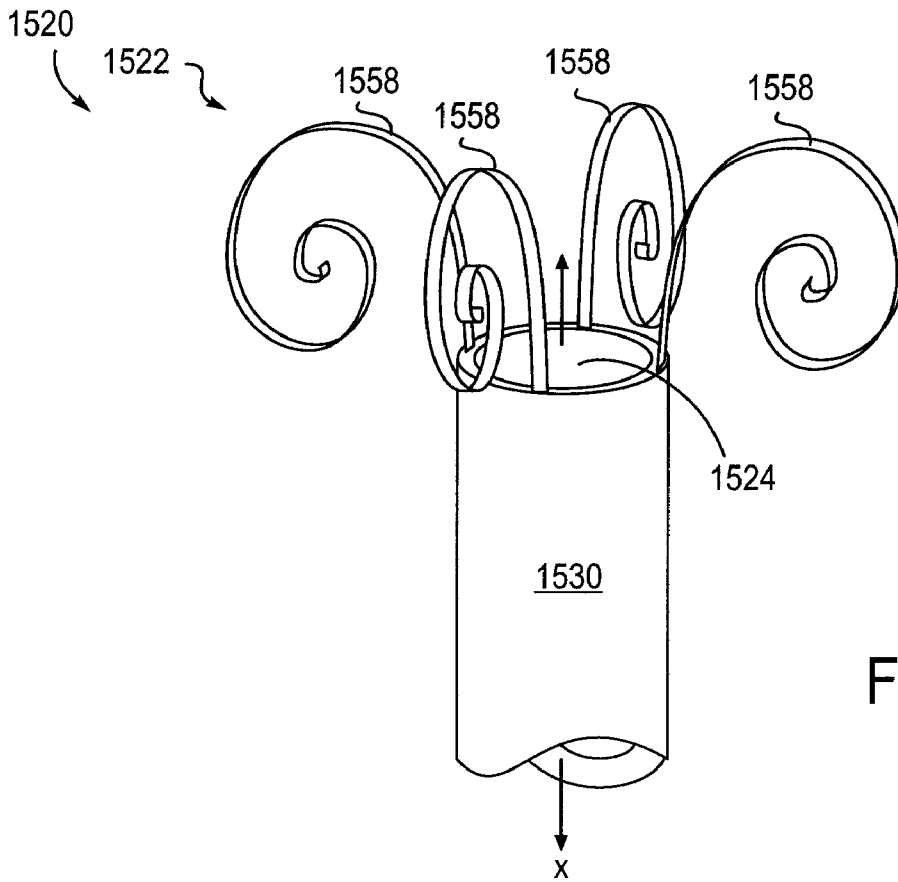

FIG. 15A

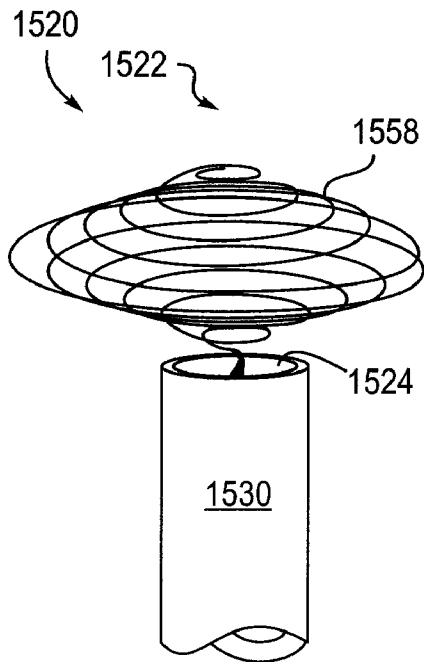

FIG. 15B(1)

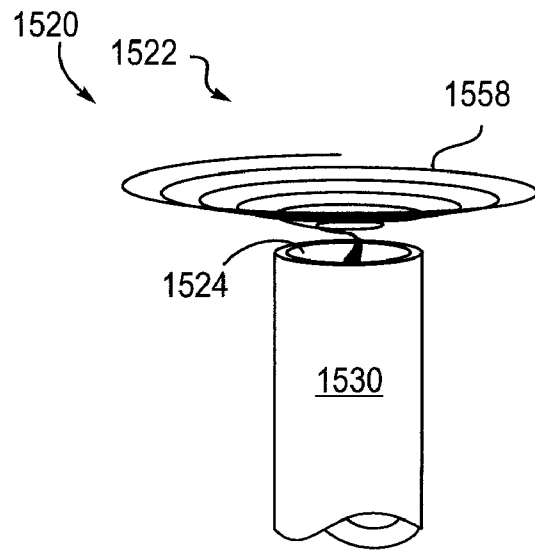

FIG. 15B(2)

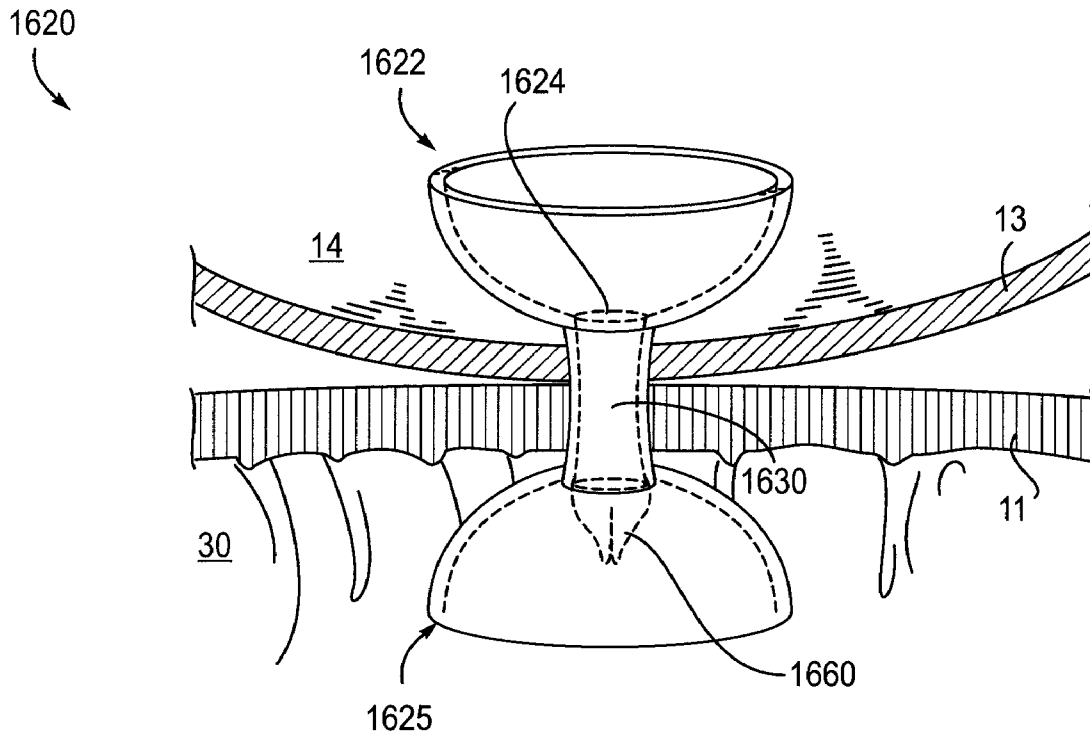

FIG. 16A

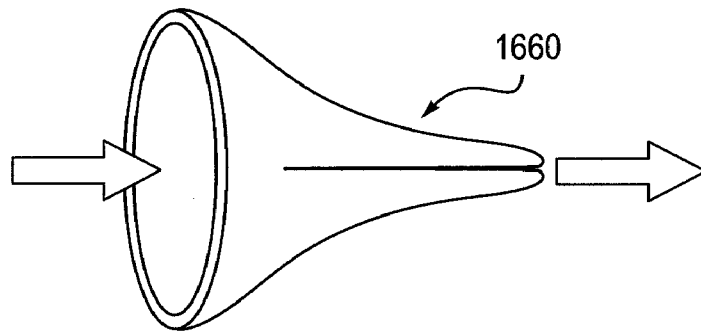

FIG. 16B

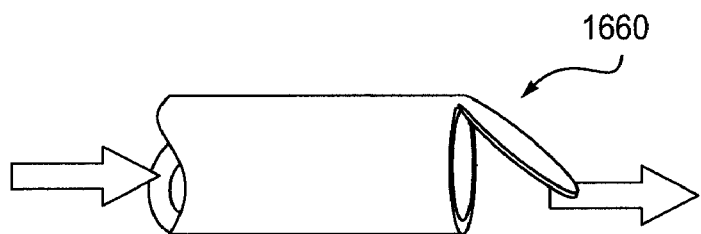

FIG. 16C

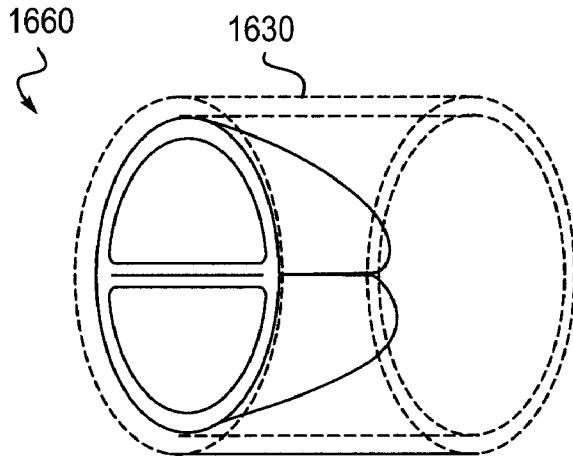

FIG. 16D(1)

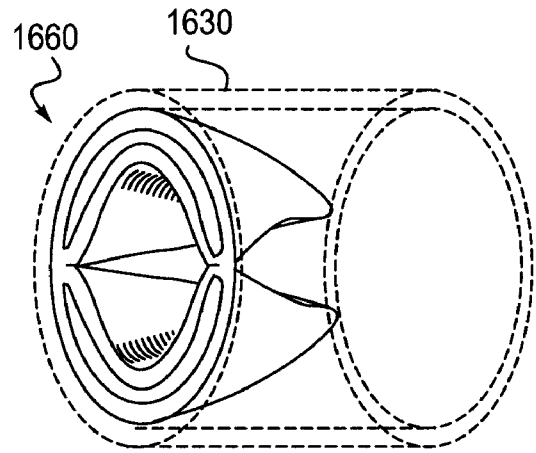

FIG. 16D(2)

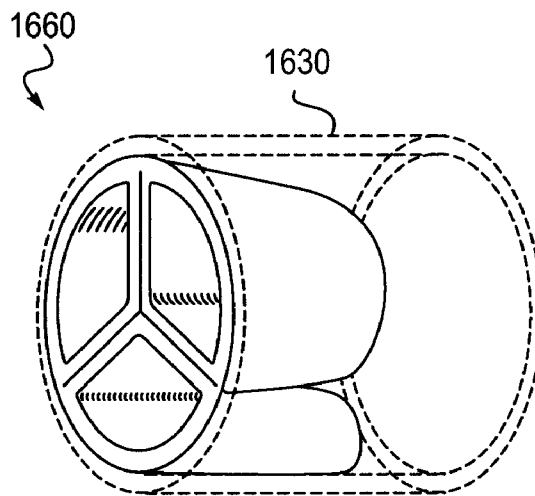

FIG. 16E(1)

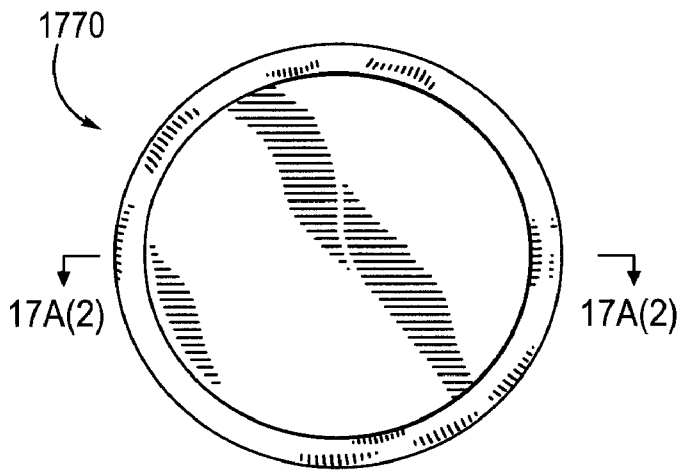

FIG. 17A(1)

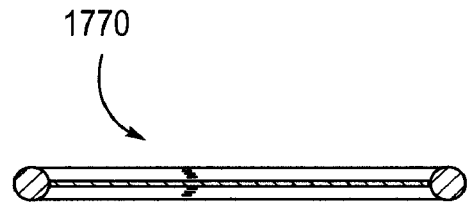

FIG. 17A(2)

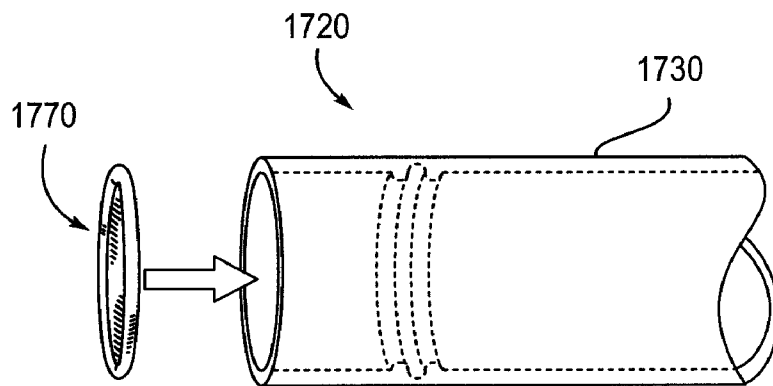

FIG. 17B

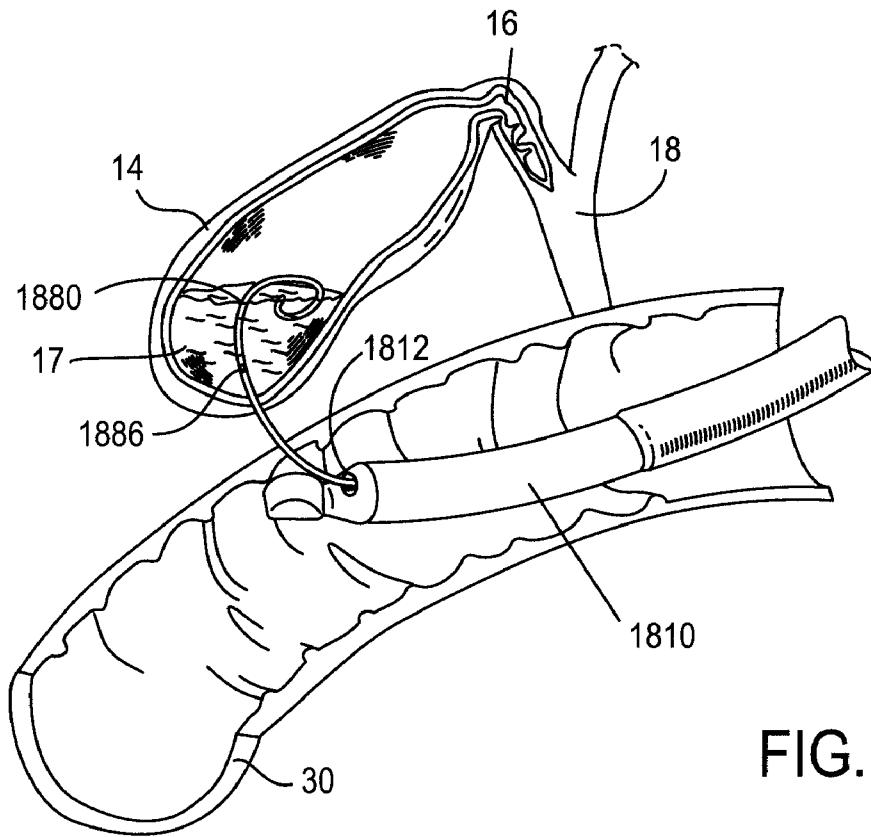

FIG. 18A

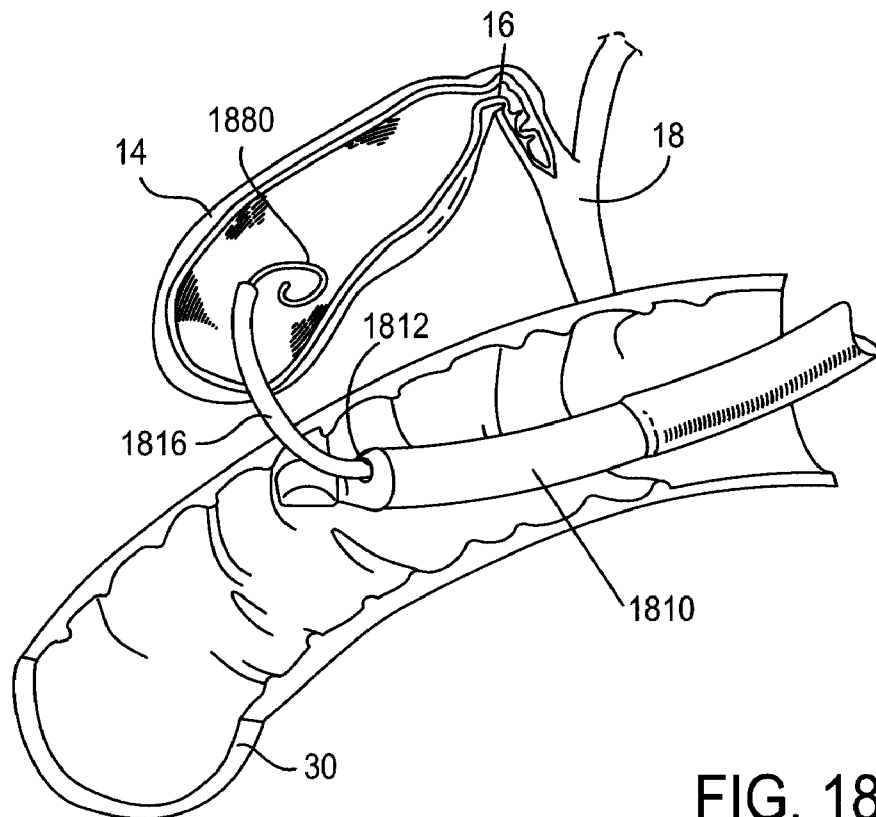
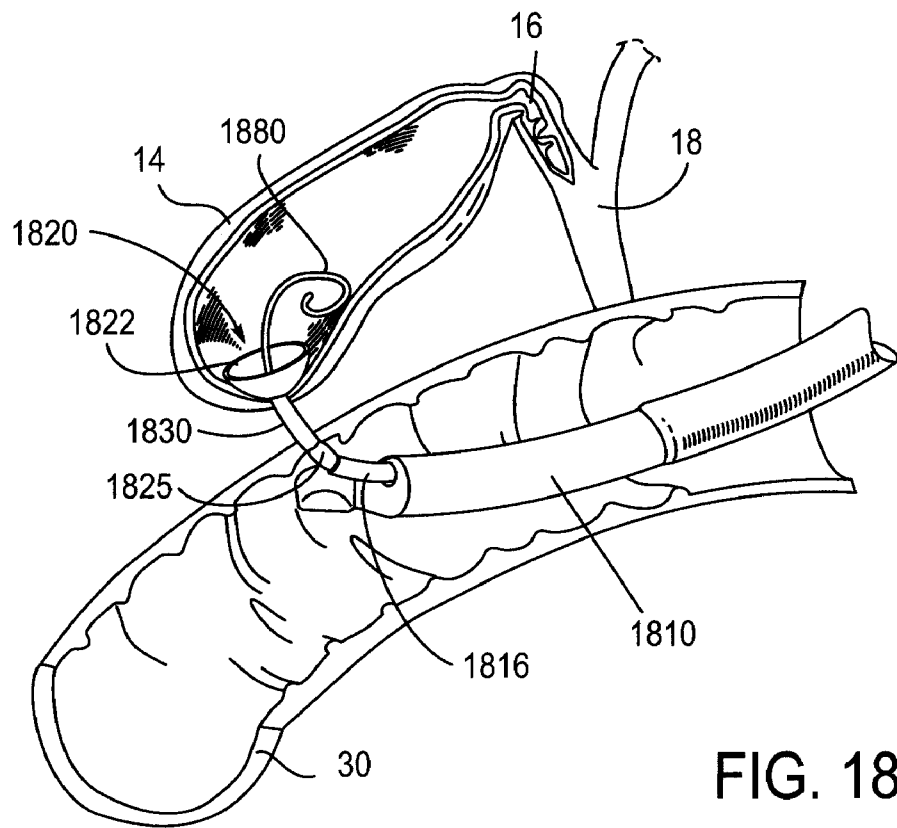
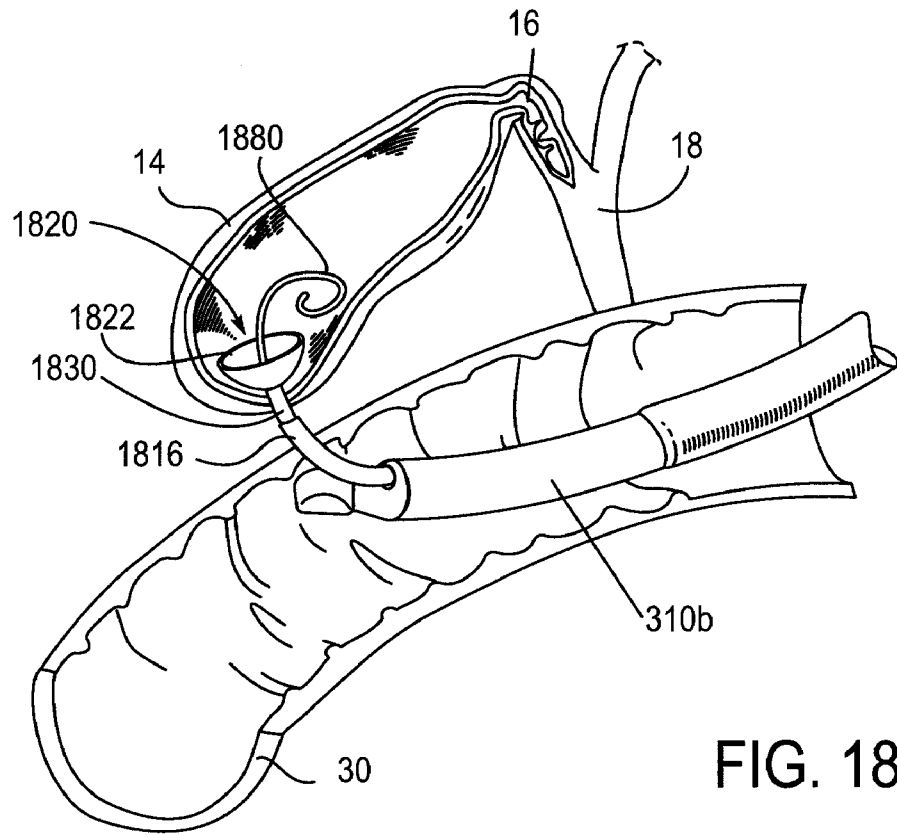

FIG. 18B



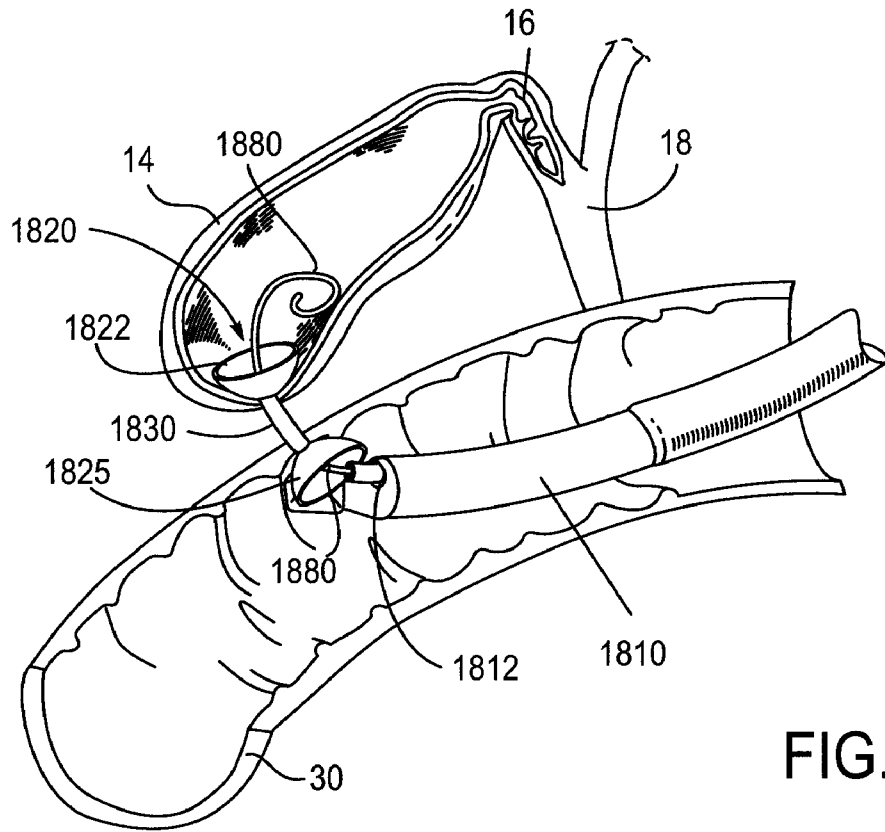

FIG. 18E

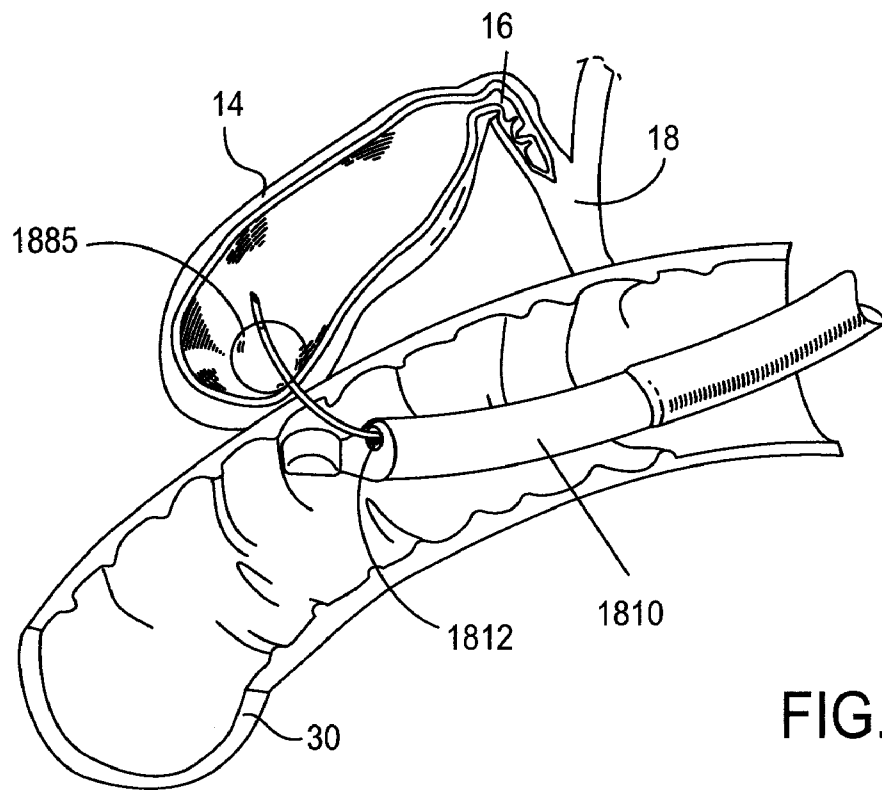

FIG. 18F

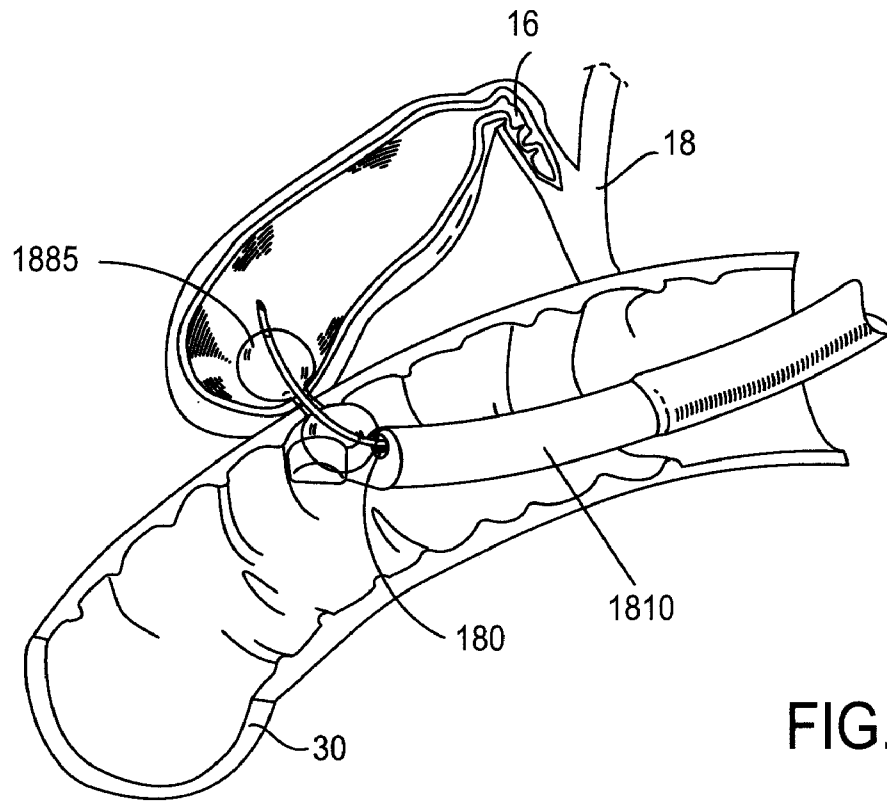

FIG. 18G

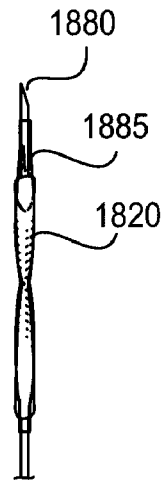

FIG. 18H

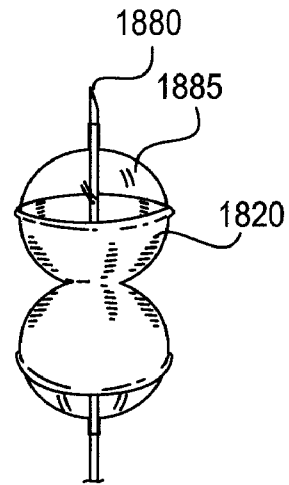

FIG. 18I

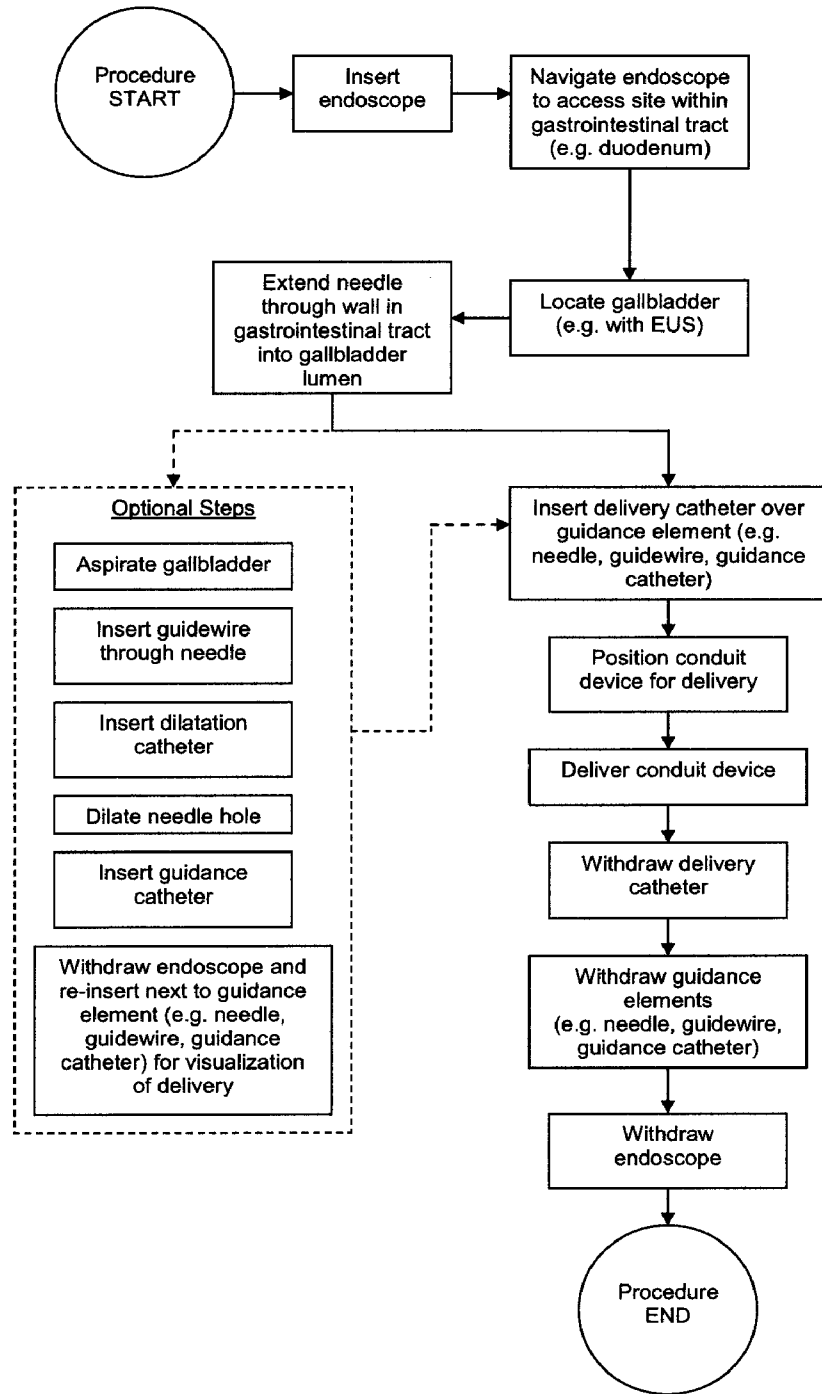

FIG. 19

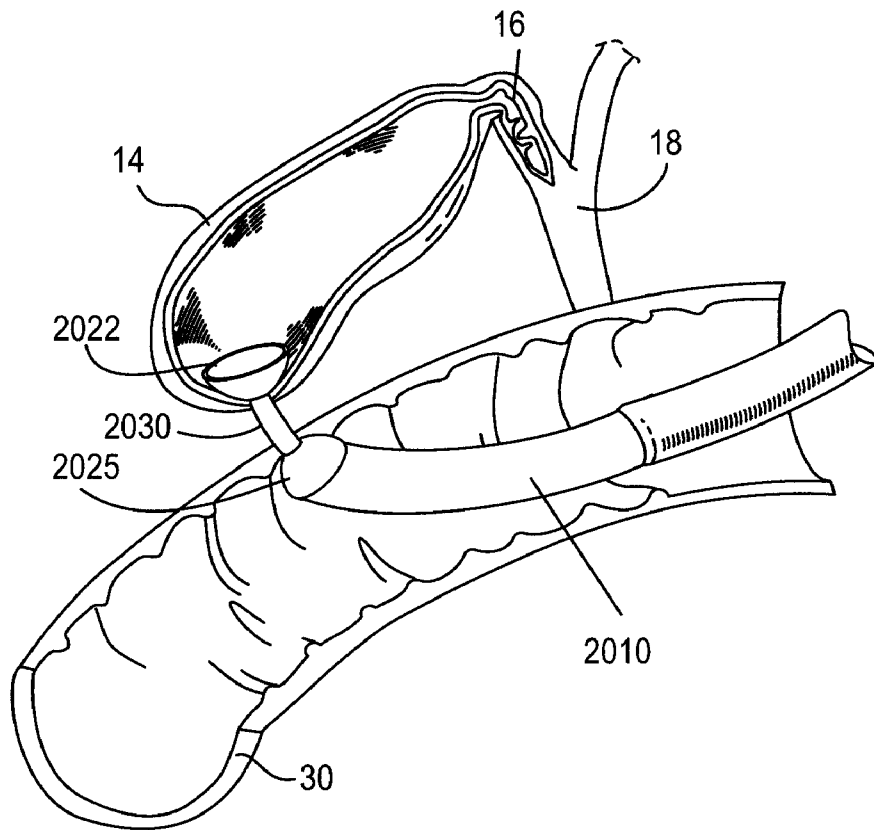

FIG. 20

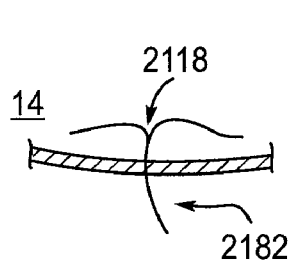

FIG. 21A

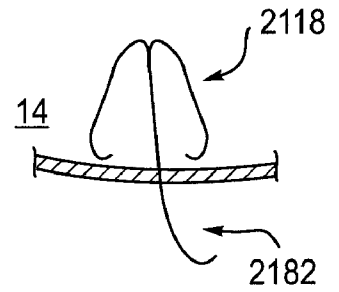

FIG. 21B

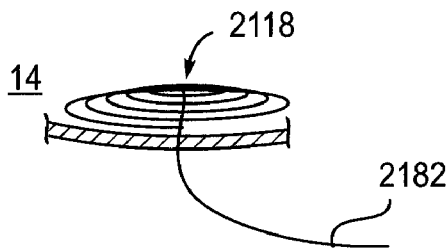

FIG. 21C

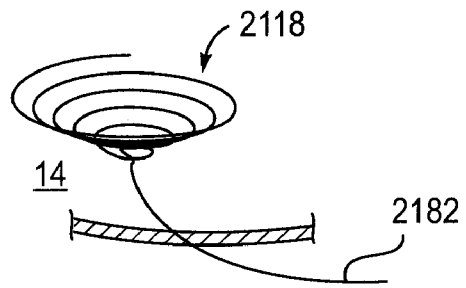

FIG. 21D

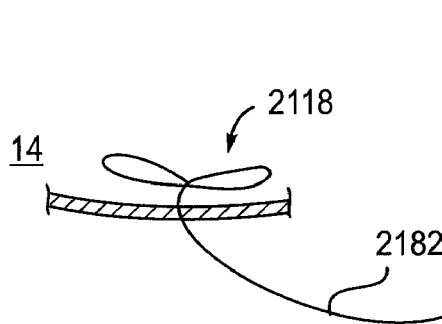

FIG. 21E

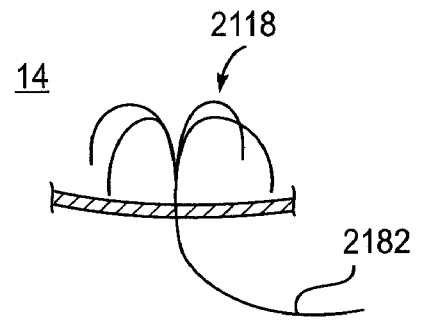

FIG. 21F

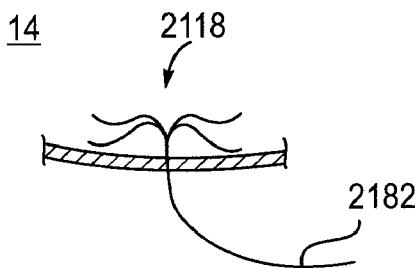

FIG. 21G

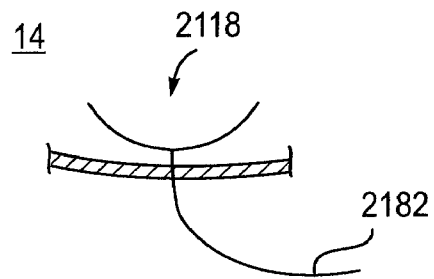

FIG. 21H