



US 20070128434A1

(19) **United States**

(12) **Patent Application Publication** (10) **Pub. No.: US 2007/0128434 A1**

Motoda et al. (43) **Pub. Date: Jun. 7, 2007**

(54) **FILLER-AFFIXED FIBER, FIBER STRUCTURE, AND FIBER MOLDED BODY, AND METHOD FOR PRODUCING THE SAME**

(75) Inventors: **Hisatoshi Motoda**, Kako-gun (JP);
Kouki Shigeta, Kakogawa-shi (JP)

Correspondence Address:
HAMRE, SCHUMANN, MUELLER & LARSON, P.C.
P.O. BOX 2902
MINNEAPOLIS, MN 55402-0902 (US)

(73) Assignee: **DAIWABO CO.,LTD.**, Osaka-shi (JP)

(21) Appl. No.: **10/566,617**

(22) PCT Filed: **Aug. 2, 2004**

(86) PCT No.: **PCT/JP04/11397**

§ 371(c)(1),
(2), (4) Date: **Jan. 31, 2006**

(30) **Foreign Application Priority Data**

Aug. 4, 2003 (JP) 2003-286185
Jun. 10, 2004 (JP) 2004-172920
Jun. 18, 2004 (JP) 2004-181415
Jun. 22, 2004 (JP) 2004-183709

Publication Classification

(51) **Int. Cl.**
D02G 3/00 (2006.01)
(52) **U.S. Cl.** **428/375**

(57) **ABSTRACT**

The filler-affixed fiber of the present invention is a filler-affixed fiber that includes a fiber (2), a binder resin (1) on the fiber surface, and filler (3) affixed to the binder resin (1). The binder resin (1) is a heat-and-humidity gelling resin that is caused to gel by heating in the presence of moisture, and the filler (3) is affixed by a gel material produced by causing the heat-and-humidity gelling resin to gel. Thus, the fiber (2) preserves the form of the fiber, and exhibits the working function as a binder that causes the filler (3) to be affixed by causing the heat-and-humidity gelling resin to gel.

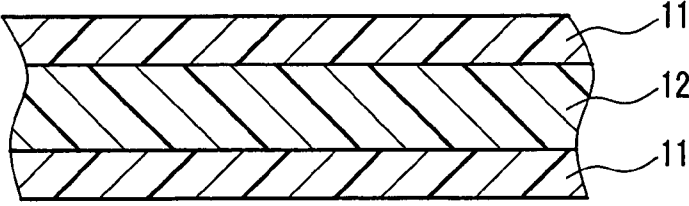
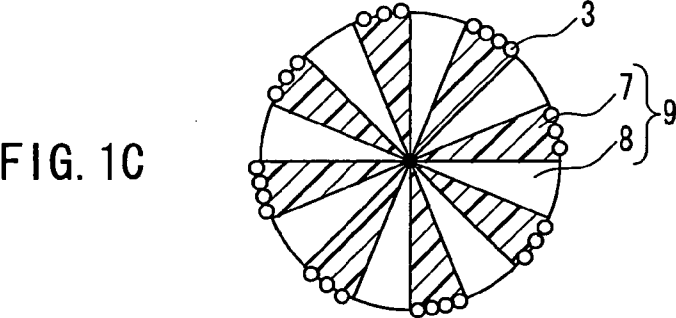
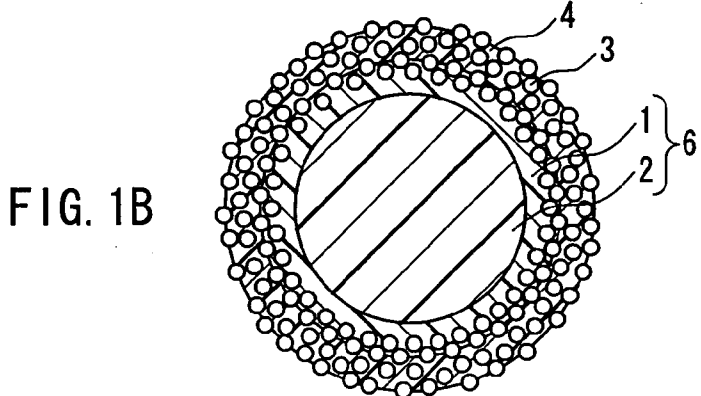
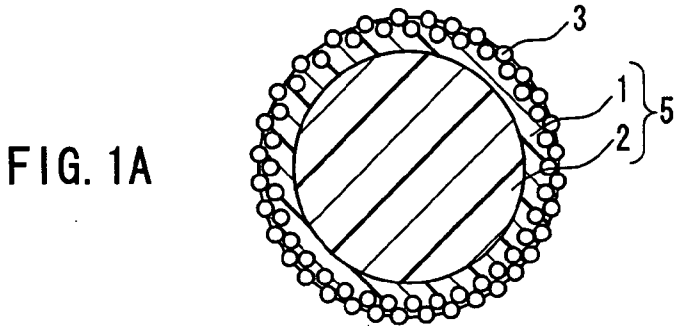

FIG. 2

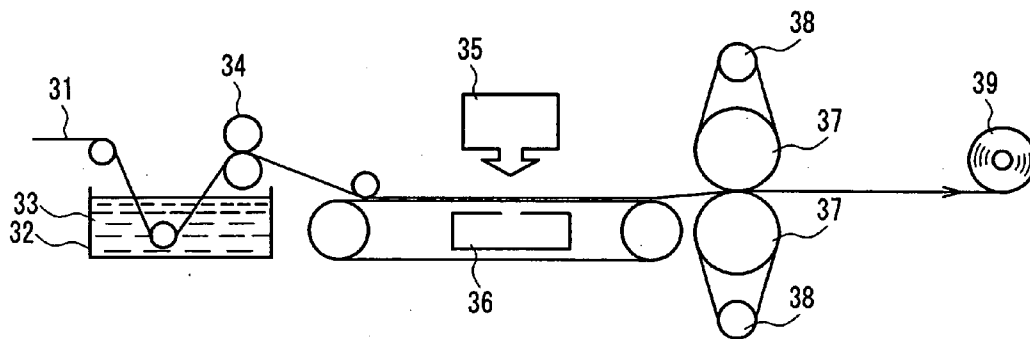

FIG. 3

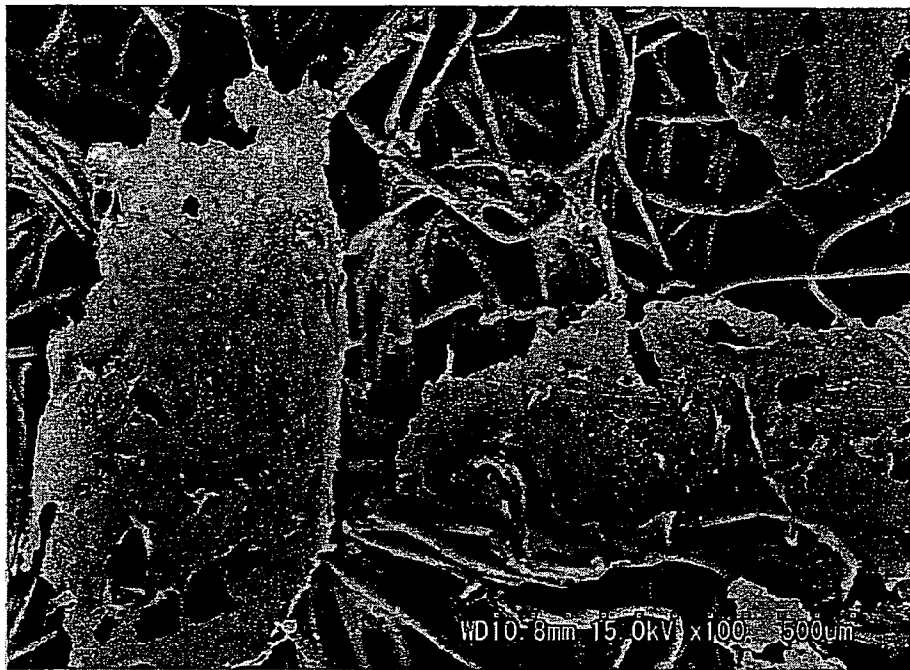

FIG. 4A

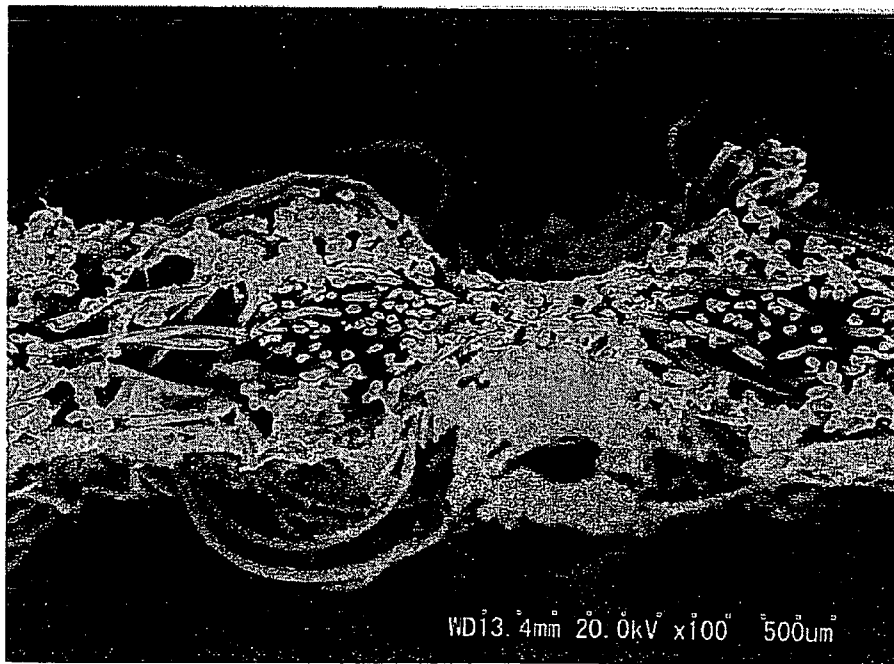

FIG. 4B

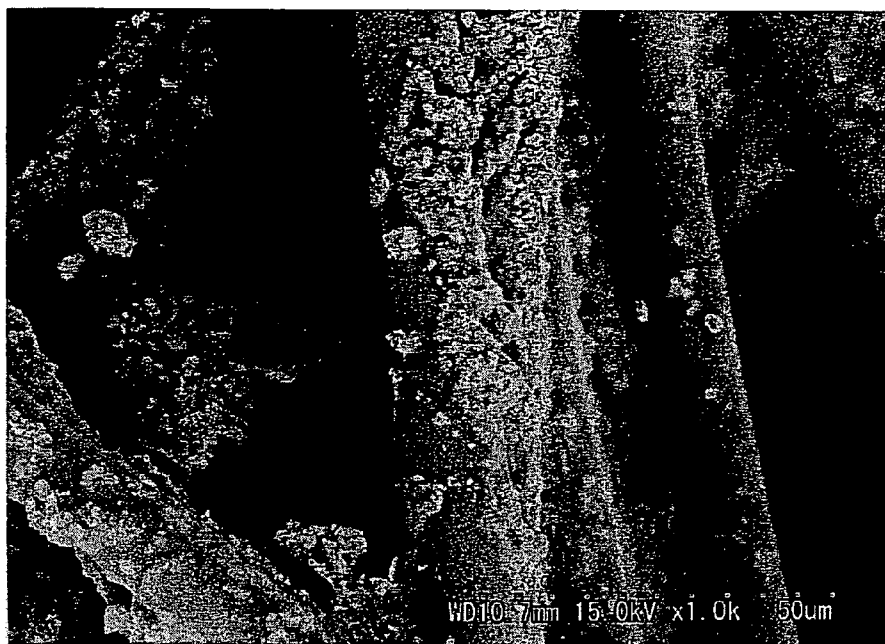

FIG. 4C

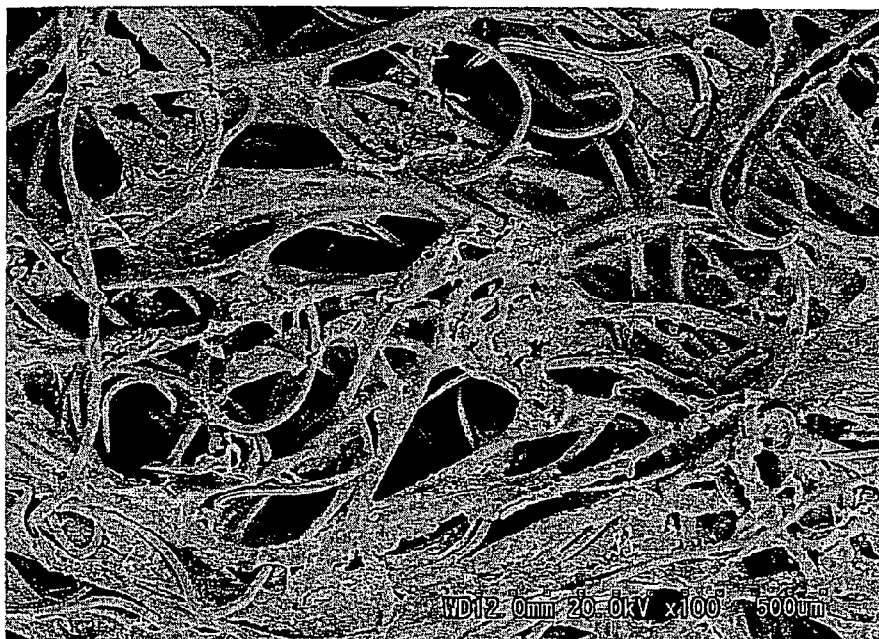

FIG. 4D

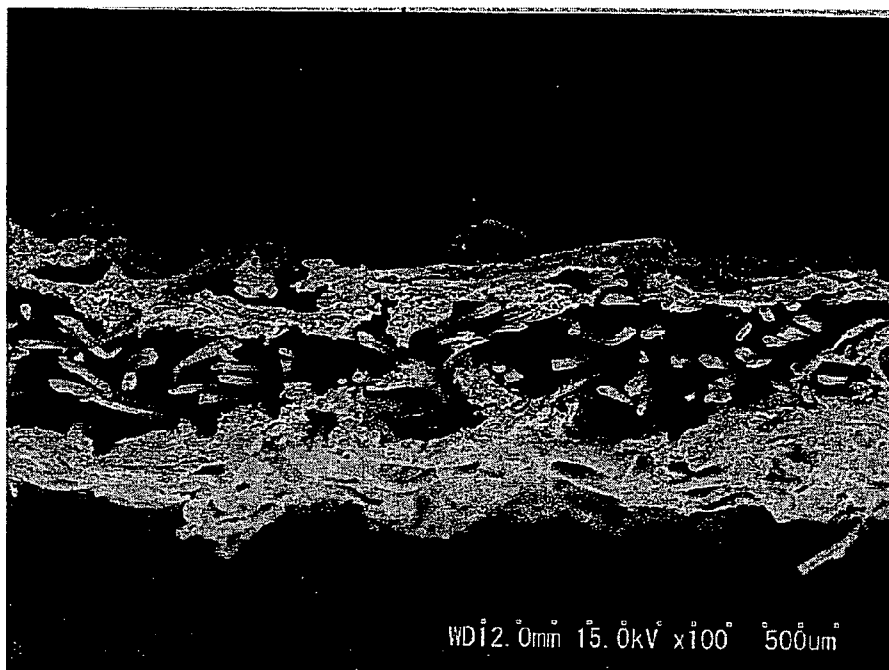

FIG. 4E

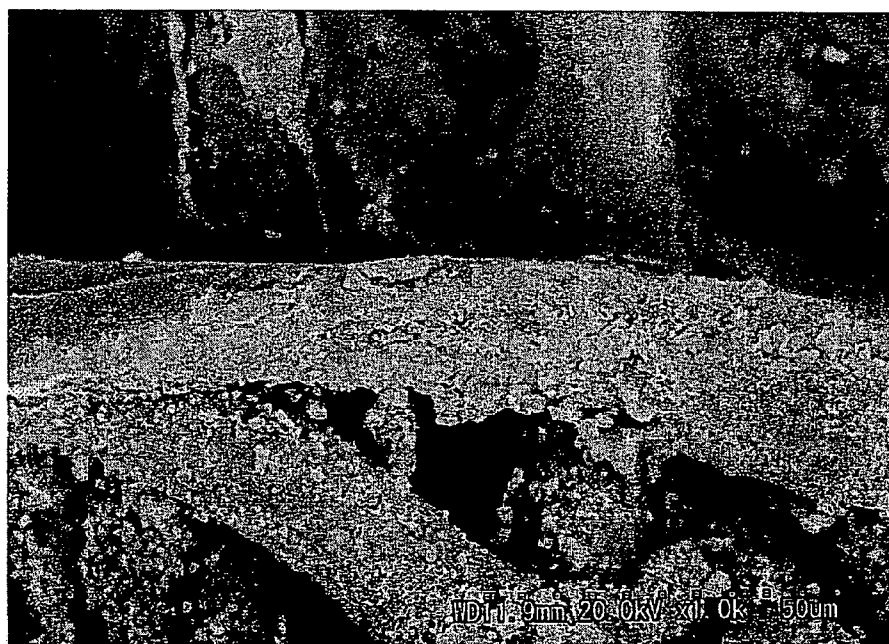

FIG. 4F



FIG. 5A



FIG. 5B

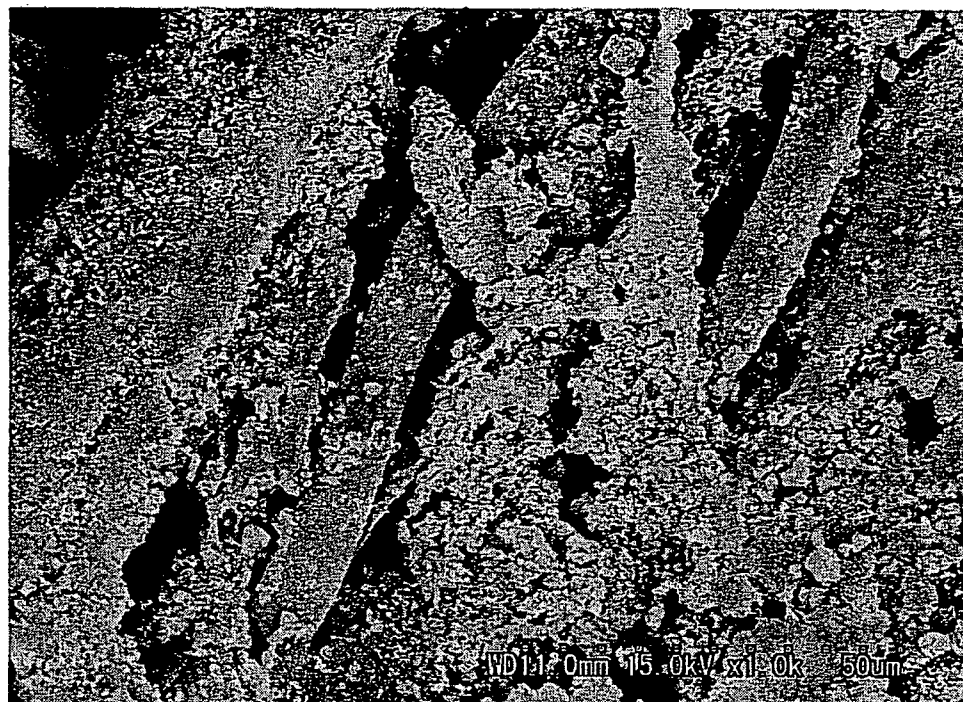

FIG. 5C

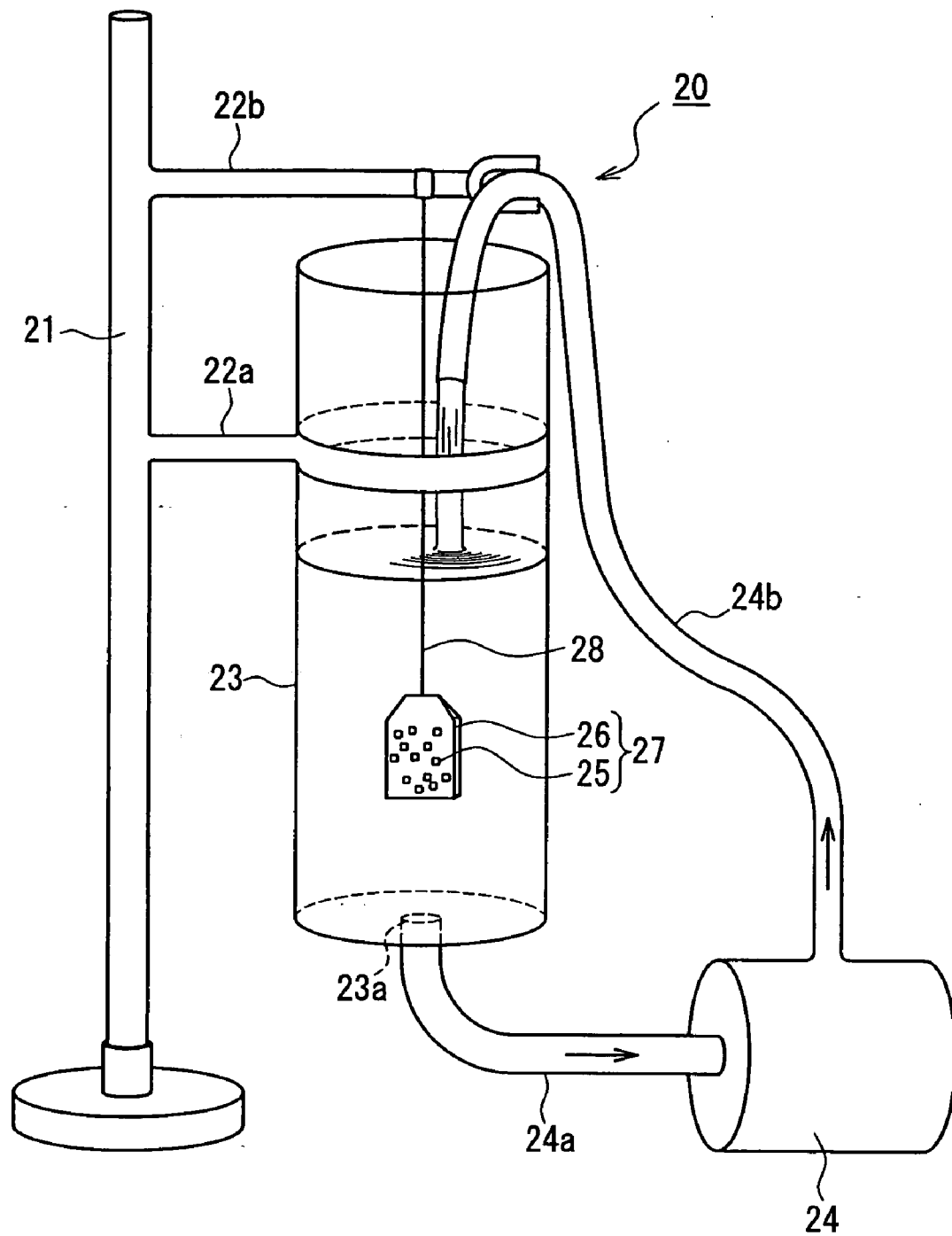

FIG. 6

FIG. 7

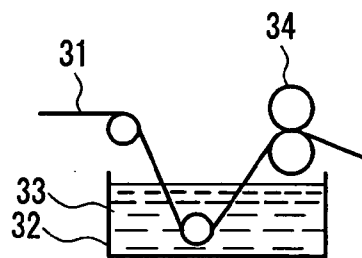

FIG. 8

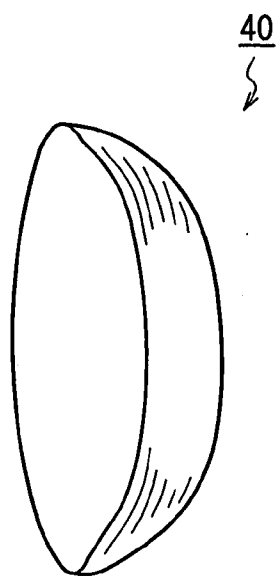
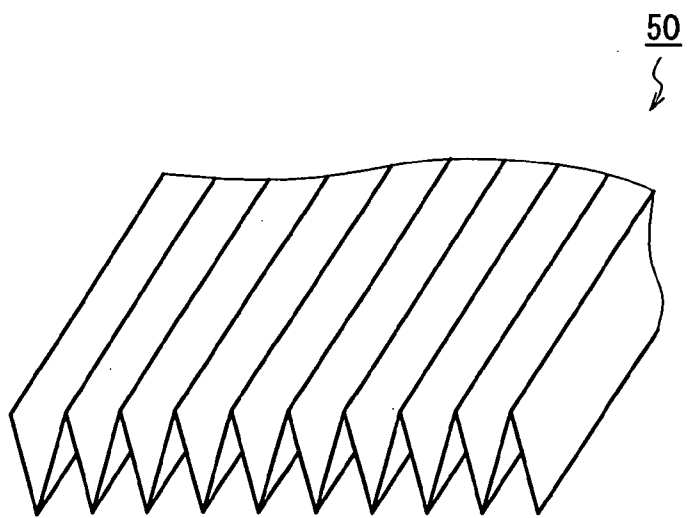

FIG. 9



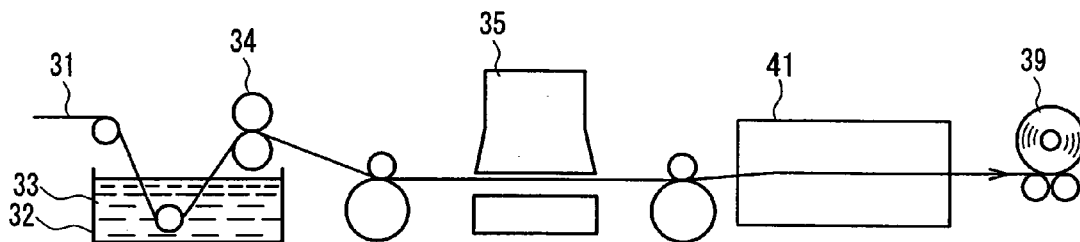

FIG. 10

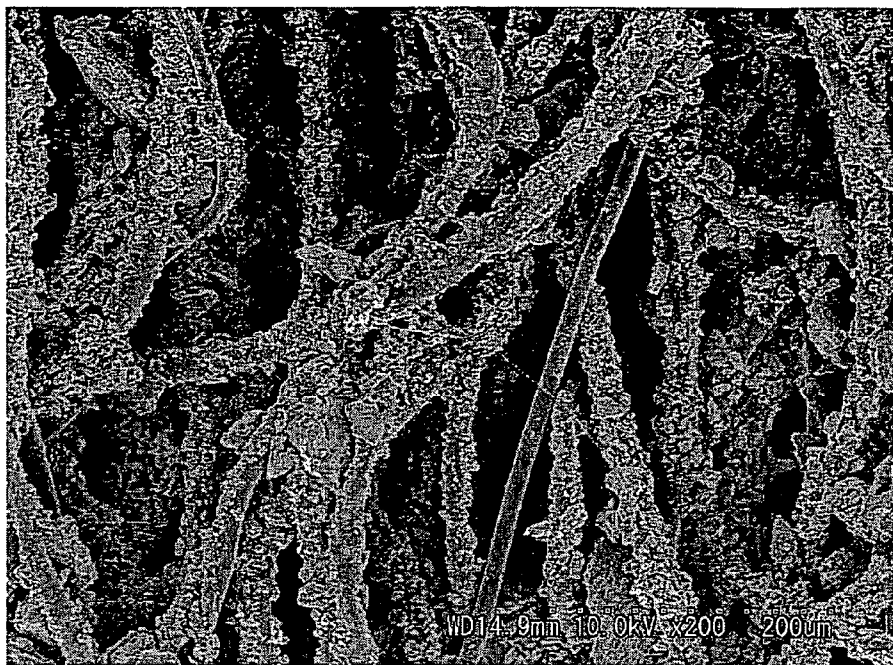

FIG. 11A

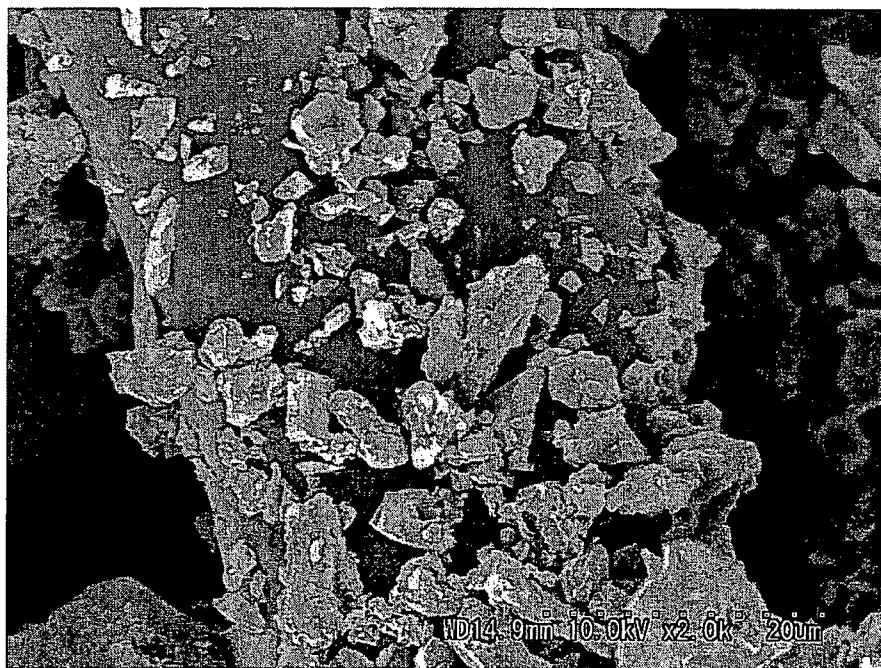

FIG. 11B

**FILLER-AFFIXED FIBER, FIBER STRUCTURE,
AND FIBER MOLDED BODY, AND METHOD FOR
PRODUCING THE SAME**

TECHNICAL FIELD

[0001] The present invention relates to a filler-affixed fiber in which filler is affixed to the fiber surface, a fiber structure, and a fiber molded body, and a method for producing the same.

BACKGROUND ART

[0002] Conventionally, a method for allowing filler to adhere to the surface of a fiber has been proposed in which after particles have been supported on the surface of a nonwoven fabric with a dry method, the particles are allowed to adhere by heating to not less than the temperature of the softening point of the fiber (below Patent Document 1). Further, a method has been proposed in which a sheet-like or block fiber mold is impregnated with a water-dispersed solution including particles, and after pressing, particles are allowed to adhere by heating to between the melting point of the fiber and a temperature that does not exceed 60° C. from the melting point of the fiber (below Patent Document 2).

[0003] Conventional fiber products in which a filler is allowed to adhere to the fiber surface are used in various applications. For example, with respect to fibers and fabrics with an objective of polishing and cleaning, filament fibers (dental floss) that polish between teeth are ordinarily well known as fibers with an objective of cleaning. Also, with respect to industrial applications, polishing cloths and polishing papers are used in various fields such as lenses, semiconductors, metals, plastics, ceramics, and glass. Polishing cloths are also used in home and industrial kitchens.

[0004] Also, because the occurrence of allergic symptoms such as sick building syndrome increases due to inhalation of volatile organic compounds hereinafter, abbreviated "VOC"), gas adsorbents that adsorb harmful gas such as VOC gas are in demand. As gas adsorbents, gas adsorbent sheets are known that have a gas adsorbent effect for VOC gas generally, as in Patent Document 3, for example. In the gas adsorbent sheet proposed in Patent Document 3, activated carbon particles are fixed by being sandwiched between two sheets of sheet material, and adsorbent particles are fixed on at least one of the sheets of sheet material. As methods of fixing the adsorbent particles, exemplary methods are disclosed (1) in which one of the sheets is coated by mixing adsorbent particles in a binder resin solution, and the other sheet is placed on top of the coated sheet, and (2) in which one of the sheets is coated in advance with hot-melt adhesive or the like, adsorbent particles are sprayed on that sheet, and the other sheet is placed on top of the coated and sprayed sheet.

[0005] Moreover, various water purifiers that purify industrial waste water or the like using activated carbon in fiber form, that is, activated carbon fiber, have been proposed (for example, such as Patent Document 4). However, with water purifiers using an activated carbon fiber, there is a risk that during use, the activated carbon that constitutes the activated carbon fiber will exfoliate and the purifying performance will worsen. There is also a risk that after purification, activated carbon that has exfoliated will be mixed into the

purified liquid. On the other hand, a water purification filter is proposed in Patent Document 5 in which organic matter adsorbent particles such as activated carbon particles are affixed to a sheet-like member via an insoluble binder.

[0006] As fiber products in which a filler is allowed to adhere to the fiber surface, there are also fiber products that have the form of a fiber molded body. For example, a manufacturing method for a fiber molded body has been proposed in which a fleece is formed by mixing particles and binder resin in fiber raw material, and after producing bulky matting fused with binder resin, press-molding in a predetermined shape is performed (below Patent Document 6). Also, a solid-body molded body has been proposed in which a functional fiber sheet, which is constituted from functional material such as plant fiber, thermal fusible fiber, and powder-like or fiber-like functional material, is molded by heat molding (below Patent Document 7).

[0007] Patent Document 1: JP H7-268767A

[0008] Patent Document 2: JP S51-22557A

[0009] Patent Document 3: JP 2000-246827A

[0010] Patent Document 4: JP H9-234365A

[0011] Patent Document 5: JP H9-201583A

[0012] Patent Document 6: JP H9-254264A

[0013] Patent Document 7: JP 2004-52116A

[0014] However, when heating the fiber to a temperature not less than the softening point or melting point as in above Patent Documents 1 and 2, there is the problem that the fiber shrinks and hardens, and at about the softening point particles cannot be fixed to the fiber effectively, so that it becomes necessary to heat to not less than the melting point, and when doing so the fiber shape cannot be preserved. Further, there is the problem that the fiber shrinks and hardens, and by extension, when the fiber is made into a nonwoven fabric, with shrinkage the shape of the nonwoven fabric cannot be preserved.

[0015] Also, in the above fixing method (1) for the gas adsorbent sheets proposed in Patent Document 3, there is a risk that the gas adsorbent particles will become buried in the binder resin solution, and it will not be possible to obtain a sufficient gas adsorbing effect. And, in the above fixing method (2), there is a risk that because the contact surface area of the hot-melt adhesive and the gas adsorbent particles is small, the adsorbent particles will exfoliate. Further, with respect to the gas adsorbent sheets proposed in Patent Document 4, in order to increase air permeability, a porous sheet material is used for at least one of the two sheets of sheet material, and when holding activated carbon particles sandwiched between the two sheets of sheet material, it is necessary to make the particle diameter of the activated carbon particles larger than the maximum hole diameter of the porous sheet material, such that the activated carbon particles do not exfoliate. Thus, activated carbon particles with a particle diameter of 100 μm to 1000 μm are used, and so there is a risk that because the specific surface area of the activated carbon particles is small, it will not be possible to obtain a sufficient gas adsorbing effect.

[0016] In the water purification filter proposed in above Patent Document 5, there is a risk that the organic adsorbent particles will be buried in the binder, the specific surface

area of the organic matter adsorbent particles will decrease, and it will not be possible to obtain sufficient purification properties.

[0017] In the molded body proposed in above Patent Document 6, particles are affixed to the fiber surface by mixing particles and binder resin in advance, and so there is the problem that particles are buried in the binder resin, and it is not possible for the function possessed by the particles to be exhibited sufficiently. Moreover, in above Patent Document 7, an attempt is made to affix particle-like functional material by fusing thermal fusible fiber, but with the method of Patent Document 7 it is not possible to affix particles if the thermal fusible fiber is not fused at a very high temperature, and there is a risk that if fusing is performed at a high temperature it will be accompanied by shrinkage, so that obtaining a uniform molded body may be difficult. It also may be difficult to produce a deep-draw molded body.

DISCLOSURE OF INVENTION

[0018] In order to solve the problems in the conventional technology described above, with the present invention it is possible to provide a filler-affixed fiber in which filler is affixed to the fiber surface effectively while preserving the inherent fiber qualities, and to provide a fiber structure useful for abrasive material, gas adsorbent material, water purifying material, and the like, with which it is possible to prevent exfoliation of filler affixed to the fiber surface and suppress a decrease in the specific surface area of the filler, and to provide a fiber molded body with which filler can be affixed effectively to the fiber surface, a deep-draw shape can be obtained with uniform molding, and molding cost can be made inexpensive even in ordinary applications, and to provide a method for producing that filler-affixed fiber, fiber structure, and fiber molded body.

[0019] The filler-affixed fiber of the present invention includes a fiber, a binder resin on the fiber surface, and a filler affixed to the binder resin, in which the binder resin is heat-and-humidity gelling resin that is caused to gel by heating in the presence of moisture, and the filler is affixed by a gel material produced by causing the heat-and-humidity gelling resin to gel.

[0020] The fiber structure of the present invention contains a filler-affixed fiber including a fiber, a binder resin on the fiber surface, and a filler affixed to the binder resin, in which the binder resin is heat-and-humidity gelling resin that is caused to gel by heating in the presence of moisture, and the filler is affixed by a gel material produced by causing the heat-and-humidity gelling resin to gel.

[0021] The fiber molded body of the present invention is made by molding a fiber structure including a fiber, a binder resin on the fiber surface, and a filler-affixed fiber affixed to the binder resin, in which the binder resin includes heat-and-humidity gelling resin that is caused to gel by heating in the presence of moisture, and in the fiber structure, the filler is fixed by a gel material produced by causing the heat-and-humidity gelling resin to gel under heat and humidity, and the fiber structure is molded in a predetermined shape.

[0022] The method for producing filler-affixed fiber of the present invention is a method for producing filler-affixed fiber including a fiber, a binder resin on the fiber surface, and

a filler affixed to the binder resin, in which the fiber and the binder resin are heat-and-humidity gelling fiber that is caused to gel by heating in the presence of moisture. In the method, a filler-dispersed solution in which the filler is dispersed in a solution is provided to the heat-and-humidity gelling fiber, and next, the heat-and-humidity gelling fiber is caused to gel by performing heat-and-humidity treatment on the heat-and-humidity gelling fiber in a heat and humidity atmosphere, so that the filler is affixed to the fiber surface by gel material.

[0023] Another method for producing filler-affixed fiber of the present invention is a method for producing a filler-affixed fiber including a fiber, a binder resin on the fiber surface, and a filler affixed to the binder resin, in which the fiber and the binder resin are another fiber and heat-and-humidity gelling resin. In the method, filler is provided after the heat-and-humidity gelling resin has been provided to the other fiber, or a filler-dispersed solution in which the filler and the heat-and-humidity gelling resin are dispersed in a solution is provided to the other fiber, and next, the heat-and-humidity gelling resin is caused to gel by performing heat-and-humidity treatment in a heat and humidity atmosphere, so that the filler is affixed to the surface of the other fibers by gel material.

[0024] The method for producing a fiber structure of the present invention is a method for producing a fiber structure that contains a filler-affixed fiber including a fiber, a binder resin on the fiber surface, and a filler affixed to the binder resin, in which the binder resin is heat-and-humidity gelling resin that is caused to gel by heating in the presence of moisture, the fiber and the binder resin are at least one combination selected from among

[0025] (I) conjugate fiber that includes a heat-and-humidity gelling resin fiber component and another thermoplastic synthetic fiber component,

[0026] (II) a mixture of the conjugate fiber and another fiber,

[0027] (III) a mixture of the conjugate fiber and heat-and-humidity gelling resin, and

[0028] (IV) a mixture of heat-and-humidity gelling resin and another fiber, a fiber structure is produced with the fiber and the binder resin, a filler-dispersed solution in which the filler is dispersed in a solution is provided to the fiber structure, and next, the heat-and-humidity gelling resin is caused to gel by performing heat-and-humidity treatment on the heat-and-humidity gelling resin in a heat and humidity atmosphere, so that the filler is affixed to the fiber surface by gel material, forming a filler-affixed fiber.

[0029] The method of producing a fiber molded body of the present invention is a method of producing a fiber molded body made by molding a fiber structure including a fiber, a binder resin on the fiber surface, and a filler-affixed fiber affixed to the binder resin, in which the binder resin includes heat-and-humidity gelling resin that is caused to gel by heating in the presence of moisture, a fiber structure including the fiber and the binder resin is produced, and heat-and-humidity mold processing is performed on the fiber structure in a metal die by causing the heat-and-humidity gelling resin to gel under heat and humidity in a heat and humidity atmosphere.

BRIEF DESCRIPTION OF DRAWINGS

[0030] FIGS. 1A to 1C are cross-sectional diagrams of filler-affixed fiber according to an embodiment of the present invention.

[0031] FIG. 2 is a cross-sectional diagram of a nonwoven fabric with a three-layer structure according to an embodiment of the present invention.

[0032] FIG. 3 is a process diagram of an example of the production method of the present invention.

[0033] FIG. 4A is a scanning electron microscope plane photograph (magnification 100) that shows the nonwoven fabric obtained in Example 1 of the present invention.

[0034] FIG. 4B is a cross-sectional photograph (magnification 100) of the nonwoven fabric in FIG. 4A.

[0035] FIG. 4C is a fiber surface magnified photograph (magnification 1000) of the surface of the nonwoven fabric in FIG. 4A.

[0036] FIG. 4D is a scanning electron microscope plane photograph (magnification 100) that shows another portion of the nonwoven fabric in FIG. 4A.

[0037] FIG. 4E is a cross-sectional photograph (magnification 100) of the portion of nonwoven fabric in FIG. 4D.

[0038] FIG. 4F is a fiber surface magnified photograph (magnification 1000) of the surface of the portion of nonwoven fabric in FIG. 4D.

[0039] FIG. 5A is a scanning electron microscope plane photograph (magnification 100) that shows a nonwoven fabric obtained in Example 6 of the present invention.

[0040] FIG. 5B is a cross-sectional photograph (magnification 100) of the nonwoven fabric in FIG. 5A.

[0041] FIG. 5C is a fiber surface magnified photograph (magnification 1000) of the surface of the nonwoven fabric in FIG. 5A.

[0042] FIG. 6 is a schematic perspective view of a water-circulating small-scale testing apparatus.

[0043] FIG. 7 is a process diagram of an example of imparting moisture to the nonwoven fabric in an embodiment of the present invention.

[0044] FIG. 8 is a perspective view of a fiber molded body (mask) in an embodiment of the present invention.

[0045] FIG. 9 is a perspective view of a fiber molded body (air cleaner filter processed to have pleats) in an embodiment of the present invention.

[0046] FIG. 10 is a process diagram of another example of the production method of the present invention.

[0047] FIG. 11A is a scanning electron microscope plane photograph (magnification 200) that shows the nonwoven fabric obtained in Example 7 of the present invention.

[0048] FIG. 11B is a fiber surface magnified photograph (magnification 2000) of the surface of the nonwoven fabric in FIG. 11A.

[0049] 1: sheath component (binder resin), 2: core component, 3: filler, 4: binder resin, 5, 6, 9: conjugate fiber, 7: ethylene-vinyl alcohol copolymer resin (binder resin), 8:

polypropylene, 11: filler-affixed fiber layers, 12: rayon fiber layer, 20: water-circulating small-scale testing apparatus, 21: stand, 22a, 22b: fixed jigs, 23: container, 24: pump 24a, 24b: tubes, 25: scraps, 26: tea bag, 27: testing sample, 28: wire, 31: fiber or nonwoven fabric, 32: tank, 33: filler-dispersed solution, 34: squeeze roll, 35: steamer, 36: vacuum, 37: heat roll, 38: patterning canvas rolls, 39: winder, 40: mask, 41: drier, 50: air cleaner filter processed to have pleats

BEST MODE FOR CARRYING OUT THE INVENTION

[0050] In the present invention, heat-and-humidity gelling resin is used as a binder resin that is caused to gel by heating in the presence of moisture. Given as examples of forms of heat-and-humidity gelling resin are powder-like, chip-like, and fiber-like heat-and-humidity gelling resins. Particularly, it is preferable that the heat-and-humidity gelling resin be in a fiber-like form. Fiber of heat-and-humidity gelling resin alone, or conjugate fiber that includes a heat-and-humidity gelling resin fiber component and another thermoplastic synthetic fiber component (below, referred to as "heat-and-humidity gelling conjugate fiber") may be used as fiber-like heat-and-humidity gelling resin (below, referred to as "heat-and-humidity gelling fiber"). Thus, the other fiber or at least the other thermoplastic synthetic fiber component preserves the form of the fiber, and exhibits a function of acting as a binder with which a filler is affixed by causing heat-and-humidity gelling resin to gel. The filler is affixed with a gel material in which heat-and-humidity gelling resin affixed to the surface of the heat-and-humidity gelling resin fiber component or fiber has been caused to gel under heat and humidity. Preferably, the filler is affixed so as to be exposed. Also, heat-and-humidity gelling fiber and/or other fiber(s) are fixed by the gel material in which heat-and-humidity gelling resin affixed to the surface of the heat-and-humidity gelling resin fiber component or fiber has been caused to gel under heat and humidity.

[0051] Also, with respect to the fiber molded body of the present invention, a fiber molded body with a predetermined shape can be molded by molding a fiber structure in a metal die in a gelled state under heat and humidity. Given as examples of forms of heat-and-humidity gelling resin are powder-like, chip-like, and fiber-like heat-and-humidity gelling resins. Particularly, considering mold workability, it is preferable that the heat-and-humidity gelling resin be in a fiber-like form, that is, that the heat-and-humidity gelling resin be heat-and-humidity gelling fiber.

[0052] The preferable gelling temperature of the heat-and-humidity gelling resin is not less than 50° C. A more preferable gelling temperature is not less than 80° C. If a resin obtained by gelling at less than 50° C. is used, when performing gel processing, there may be instances in which production of a fiber structure and fiber molded body becomes difficult because the resin adheres strongly to the metal die, roll, or the like, or in which the resin cannot be used in the summertime or in a high temperature environment. "Gel processing" means processing that causes the heat-and-humidity gelling resin to gel.

[0053] It is preferable that the heat-and-humidity gelling resin is ethylene-vinyl alcohol copolymer resin. This is because it can be caused to gel by heat and humidity, and

will not cause a change in the qualities of other fibers and/or other thermoplastic synthetic fiber components. Ethylene-vinyl alcohol copolymer resin is resin that can be obtained by saponifying ethylene-vinyl acetate copolymer resin, and it is preferable that the degree of saponification be not less than 95%. A more preferable degree of saponification is not less than 98%. Also, the proportion of ethylene included is preferably not less than 20 mole %. The proportion of ethylene included is preferably not more than 50 mole %. The proportion of ethylene included is more preferably not less than 25 mole %. The proportion of ethylene included is more preferably not more than 45 mole %. At a degree of saponification of less than 95%, when performing gel processing, there may be instances in which production of a fiber structure and fiber molded body becomes difficult because the resin adheres to the metal die, roll, or the like. Also, as in the case when the proportion of ethylene included is less than 20 mole %, when performing gel processing, there may be instances in which production of a fiber structure and fiber molded body becomes difficult because the resin adheres to the metal die, roll, or the like. On the other hand, when the proportion of ethylene included exceeds 50 mole %, the heat-and-humidity gelling temperature increases, it is necessary to increase the processing temperature to near the melting point, and as a result, there may be a detrimental effect on the dimensional stability of the fiber structure and fiber molded body.

[0054] As preferable combinations of the fiber and the binder resin, at least one that is selected from among the following (below, referred to as forms (I) to (IV)) is given:

[0055] (I) a conjugate fiber that includes a heat-and-humidity gelling resin fiber component and another thermoplastic synthetic fiber component,

[0056] (II) a mixture of the conjugate fiber and another fiber,

[0057] (III) a mixture of the conjugate fiber and heat-and-humidity gelling resin, and

[0058] (IV) a mixture of heat-and-humidity gelling resin and another fiber. The above form (I) is a heat-and-humidity gelling conjugate fiber in which "binder resin" is a heat-and-humidity gelling resin fiber component and "fiber" is another thermoplastic synthetic fiber component. The above form (II) is a mixture in which "binder resin" is a heat-and-humidity gelling conjugate fiber and "fiber" is other fibers, and these are mixed. The above form (III) is a mixture in which "fiber" is heat-and-humidity gelling conjugate fiber and "binder resin" is heat-and-humidity gelling resin, and these are mixed. The above form (IV) is a mixture in which "binder resin" is heat-and-humidity gelling resin that takes a form other than the heat-and-humidity gelling conjugate fiber (for example, fiber of heat-and-humidity gelling resin alone), and "fiber" is other fibers.

[0059] It is preferable that the heat-and-humidity gelling conjugate fiber used in above forms (I) to (III) is a conjugate fiber in which the heat-and-humidity gelling resin fiber component is exposed or partially divided. With respect to the form of that conjugate, a concentric type, an eccentric core-in-sheath type, a side-by-side type, a splittable type, a sea-island type, and the like are indicated. A concentric type is particularly preferable because with this type, filler easily is affixed to the fiber surface. The fiber may have any

cross-sectional shape, including a circle, a hollow shape, modified cross section, an ellipse, a star, a flat shape, and the like, but a circle is preferable from the viewpoint of ease of fiber production. It is preferable that a splittable conjugate fiber is partially segmented in advance by treatment with a jet of a high pressure water stream or the like. In such a case, the segmented heat-and-humidity gelling resin fiber component is caused to gel by a heat-and-humidity treatment, gel material is formed and allowed to adhere to the surface of the other fibers, and thus filler is affixed. That is, the conjugate fiber functions as a binder.

[0060] It is preferable that the heat-and-humidity gelling resin fiber component accounts for 10 mass % or more and 90 mass % or less of the heat-and-humidity gelling conjugate fiber. The amount of the heat-and-humidity gelling resin fiber component included is more preferably at least 30 mass %. The amount of the heat-and-humidity gelling resin fiber component included is more preferably not more than 70 mass %. When the amount of the heat-and-humidity gelling resin fiber component included is less than 10 mass %, there is a tendency for it to become difficult for the filler to be affixed. When the amount of the heat-and-humidity gelling resin fiber component included exceeds 90 mass %, there is a tendency for the fiber-formability of the conjugate fiber to decrease.

[0061] The other thermoplastic synthetic fiber component in the heat-and-humidity gelling conjugate fiber may be any of a polyolefin, polyester, polyamide, or the like, and preferably is a polyolefin. When ethylene-vinyl alcohol copolymer resin is used as the heat-and-humidity gelling resin fiber component, it is easy to form conjugate fiber (conjugate fiber) by melt spinning.

[0062] Also, as the other thermoplastic synthetic fiber component, it is preferable to use a thermoplastic synthetic fiber component that has a melting point higher than the temperature at which the heat-and-humidity gelling resin fiber component is caused to gel. When the thermoplastic synthetic fiber component has a melting point lower than the temperature at which the other thermoplastic synthetic fiber component forms a gel material, there is a tendency for the other thermoplastic synthetic fiber component itself to melt and harden, and when, for example, making the fiber molded body, it may become non-uniform with shrinkage.

[0063] The proportion of the fiber structure occupied by the heat-and-humidity gelling conjugate fiber is not particularly limited as long as it is an amount with which it is possible to affix the filler, but it is preferable that the proportion of conjugate fiber necessary to fix fiber with gel material and/or effectively affix the filler is not less than 10 mass %. A more preferable proportion of conjugate fiber is not less than 30 mass %. A still more preferable proportion of conjugate fiber is not less than 50 mass %. For example, in a resin structure, when a web that includes conjugate fiber is present on both surfaces, and another fiber is present inside, this indicates an amount contained in the web including conjugate fiber.

[0064] In the above form (III), in the heat-and-humidity gelling conjugate fiber, it is also possible further to include heat-and-humidity gelling resin and form gel material on the surface of the conjugate fiber. Thus, it is possible to improve the filler affixing effect further.

[0065] As the other fibers used in the above form (II) or above form (IV), it is possible to select and use desired

fibers, including chemical fibers such as rayon, natural fibers such as cotton, hemp, and wool, and synthetic fibers containing synthetic resins such as polyolefin resin, polyester resin, polyamide resin, acrylic resin, and polyurethane resin as a single component or a plurality of components.

[0066] In the above form (IV), it is preferable that the heat-and-humidity gelling resin is included within a range of not less than 1 mass % and not more than 90 mass % relative to the fiber structure. A more preferable amount to include is not less than 3 mass % and not more than 70 mass %. When the amount of heat-and-humidity gelling resin included is less than 1 mass %, there is a tendency for it to become difficult to fix other fibers with the gel material, or difficult to affix filler. When the amount of heat-and-humidity gelling resin included exceeds 90 mass %, there may be instances when the fiber shape is lost and becomes film-like, or the filler is buried in the gel material.

[0067] Any sort of filler may be used as long as it is in the form of particles. For example, inorganic particles are preferable as the filler. This is because if the filler is inorganic particles, when used as an abrasive it will have a large amount of abrasive action. Alumina, silica, tripoli, diamond, corundum, emery, garnet, flint, synthetic diamond, boron nitride, carbon silicon, carbon boron, chrome oxide, cerium oxide, iron oxide, colloid silicate, carbon, graphite, zeolite and titanium dioxide, kaolin, and clay can be given as examples of inorganic particles. These particles can be mixed and used as appropriate.

[0068] When the filler is gas adsorbent particles, the gas adsorbent particles are not particularly limited as long as they have a function to adsorb gaseous substances in air, but it is preferable that the gas adsorbent particles be activated carbon particles, porous particles such as zeolite, silica gel, activated white clay, and layered phosphate, porous particles in which a chemical adsorbent is supported in these porous particles, or the like. Among porous particles, activated carbon particles are particularly preferable.

[0069] When the filler is organic adsorbent particles, the organic matter adsorbent particles are not particularly limited as long as they have a function to adsorb organic matter in liquid, but it is preferable that the organic matter adsorbent particles be activated carbon particles, porous particles such as zeolite, silica gel, activated white clay, and layered phosphate, porous particles in which an organic matter adsorbent is supported in these porous particles, or the like. Among porous particles, activated carbon particles are particularly preferable.

[0070] Other than the above abrasives, gas adsorbent particles, and organic matter adsorbent particles, it is also possible to use one or two or more functional fillers such as, for example, a silica gel as a drying agent, titanium dioxide as a photocatalyst, virus adsorbent/decomposing agent, antibacterial agent, deodorant, conducting agent, antistatic agent, humidity controlling agent, insect repellent, mold preventing agent, or fire retardant.

[0071] The average particle diameter of the filler preferably has a range of 0.01 to 100 μm . A more preferable average particle diameter is not less than 0.5 μm , and a still more preferable average particle diameter is not less than 1 μm . A more preferable average particle diameter is not more than 80 μm . At an average particle diameter of less than 0.01

μm , there may be instances when the filler is buried in the gel material. On the other hand, when the average particle diameter exceeds 100 μm , the specific surface area of the filler decreases, and it may not be possible to obtain a sufficient filler function, such as a gas adsorption effect.

[0072] The fiber structure includes the fiber and the binder resin. The fiber structure referred to here is material formed by a fiber such as a fiber bundle, fiber mass, nonwoven fabric, woven knitted material, or netting. Particularly, nonwoven fabric can be applied to various applications because of its high workability. For example, when using nonwoven fabric as abrasive nonwoven fabric in which liquid is carried by the fiber structure of the present invention, it is preferable that filler-affixed fiber is present on both surfaces in a web-like form, and hydrophilic fiber is made present inside. It is preferable that the hydrophilic fiber is at least one fiber selected from rayon fiber, cotton fiber, and pulp. This is because there is good moisture retention when providing a liquid such as water, surfactant, or detergent, and then polishing.

[0073] In an embodiment of the present invention, for example, gas adsorbent material using gas adsorbent particles as filler is not limited to nonwoven fabric, and may be made a gas adsorbent module in which a fiber bundle formed by bundling a plurality of the filler-affixed fibers is made a gas adsorbing portion. Also, it is possible to use an aggregate of the filler-affixed fibers rolled into a cylindrical shape or formed in a pleated shape as a gas adsorbent filter. Also, a water purifier in which organic matter adsorbent particles are used as filler is not limited to nonwoven fabric, and may be made a water purification module in which a fiber bundle formed by bundling a plurality of the filler-affixed fibers is made an organic matter adsorbing portion. Also, it is possible to use an aggregate of the filler-affixed fibers rolled into a cylindrical shape or formed in a pleated shape as a water purification filter.

[0074] When the fiber structure is mold-processed with a metal die, it is preferable that the fiber structure is nonwoven fabric. When the fiber structure is nonwoven fabric, the cost of production is low, processing is performed easily, and when moisture is present during mold-processing, the nonwoven fabric easily follows the shape of the metal die with a moderate amount of stretching, and it is easy to obtain a deep-draw molded body.

[0075] The preferable mass per unit area of the fiber structure is not less than 20 g/m^2 and not more than 600 g/m^2 . The preferable thickness of the fiber structure (with a load of 2.94 cN/cm^2) is a range of not less than 0.1 mm and not more than 3 mm.

[0076] In order for the fiber structure to allow the functionality of filler to be effectively exhibited, it is preferable that the amount of the filler affixed is not less than 2 grams per 1 m^2 of the fiber structure, more preferably not less than 10 g, and particularly preferably not less than 20 g.

[0077] Following is a description of a method for producing the filler-affixed fiber and fiber structure of the present invention. The heat-and-humidity treatment in the present invention is performed in a heat-and-humidity atmosphere. The "heat-and-humidity atmosphere" mentioned here means a heated atmosphere including moisture. The above heat-and-humidity treatment indicates a treatment in which, for

example, heating is performed after a filler-dispersed solution that includes a filler is provided to a fiber to which a binder resin has been provided, a fiber including heat-and-humidity gelling fiber component, or fiber structure that includes these fibers, or a treatment in which heating is performed while providing the filler-dispersed solution. Given as examples of the method of heating are a method of exposing in a heated atmosphere, a method of causing penetration into a heated atmosphere, and a method of causing contact with a heated body.

[0078] In the case of heating after providing the filler-dispersed solution, the proportion of moisture (hereinafter, referred to as the "moisture ratio") provided to the fiber or fiber structure in the heat-and-humidity treatment is preferably 20 mass % to 800 mass %. A more preferable moisture ratio is not less than 30 mass %. A more preferable moisture ratio is not more than 700 mass %. A still more preferable moisture ratio is not less than 40 mass %. A still more preferable moisture ratio is not more than 600 mass %. When the moisture ratio is less than 20 mass %, there may be instances in which gelling under heat and humidity does not occur sufficiently. On the other hand, when the moisture ratio exceeds 800 mass %, there is a tendency for the heat-and-humidity treatment not to be performed uniformly between the surface and interior of the fiber structure, so that the degree of gelling under heat and humidity becomes non-uniform. As the method of providing moisture, it is possible to perform a well-known method such as spraying or dipping in a water tank. Particularly, with a method of causing filler-dispersed solution to be impregnated into the fiber structure, it is likely that much of the filler will be taken into the fiber structure, and so such a method is preferable. The fiber or fiber structure to which moisture has been provided, can be adjusted to a predetermined moisture ratio with a method such as squeezing with a squeeze roll or the like.

[0079] In the case of heating while providing the filler-dispersed solution, because gelling of the heat-and-humidity gelling resin proceeds at the same time as providing moisture, the amount of affixed filler may be regulated by regulating the concentration of filler in the filler-dispersed solution and the temperature of the filler-dispersed solution. Specifically, by impregnating the fiber or fiber structure with heated water (not less than 90° C.) including filler, it is possible to affix filler to the fiber surface.

[0080] Hydrophilic treatment may be performed on the fiber structure before the heat-and-humidity treatment. When hydrophilic treatment is performed, when the fiber structure includes hydrophobic fiber, it is possible to provide moisture to the fiber structure approximately uniformly. As a result, conjugate fiber is caused to gel under heat and humidity approximately uniformly, and filler easily is affixed, which is preferable. Examples of hydrophilic treatment include a surfactant treatment, corona discharge and glow discharge methods, plasma treatment method, electron irradiation method, ultraviolet irradiation method, gamma irradiation method, photon method, flame method, fluorine treatment method, graft treatment method, and sulfonation treatment method.

[0081] It is preferable that the heat-and-humidity treatment temperature in the heat-and-humidity treatment is not less than the gelling temperature of the heat-and-humidity

gelling resin or heat-and-humidity gelling resin fiber component (hereinafter, both referred to together as "binder resin") and not more than the melting point minus 20° C. A more preferable heat-and-humidity treatment temperature is not less than 50° C. A still more preferable heat-and-humidity treatment temperature is not less than 80° C. On the other hand, a more preferable heat-and-humidity treatment temperature is not more than the melting point of the binder resin minus 30° C. A still more preferable heat-and-humidity treatment temperature is not more than the melting point of the binder resin minus 40° C. When the heat-and-humidity treatment temperature is less than the gelling temperature of the binder resin, there may be instances in which it is not possible to effectively affix the filler. When the heat-and-humidity treatment temperature exceeds the melting point of the binder resin minus 20° C., because the temperature is near the melting point of the binder resin, there may be instances in which shrinkage is caused when using a fiber structure.

[0082] In the heat-and-humidity treatment, in the case of causing contact with a heated body, it is preferable that surface pressure is 0.01 to 0.2 MPa. A more preferable lower limit of surface pressure is 0.02 MPa. A more preferable upper limit of surface pressure is 0.08 MPa. Also, in the case of treatment in which the heated body is compression molded by a heat roll, it is preferable that the heat roll has a line pressure of 10 to 400 N/cm. A more preferable heat roll line pressure is 50 N/cm. A more preferable upper limit of the heat roll line pressure is 200 N/cm. With this method, at the same time that the heat-and-humidity gelling resin fiber component is caused to gel momentarily under heat and humidity, the gel material can be pressed and spread, and so filler can be affixed across a wide surface area. Also, with this method, when gelling is caused under heat and humidity, the filler is pressed into the gel material, and can be affixed more strongly to the fiber surface.

[0083] When providing bulkiness and/or flexibility to the fiber structure, by steam-treating a web or the like that includes the fiber and the heat-and-humidity gelling resin, a gel material is formed in which the heat-and-humidity gelling resin is gelled, and the filler can be fixed. Examples of the steam treatment method include a method of spraying steam from above and/or below the web or the like, and a method of exposing to steam with an autoclave or the like. With this method, pressure is not added to the fiber structure any more than necessary during the gelling process. As a result, in the fiber structure, filler can be affixed to the fiber surface in an exposed state while preserving the fiber form.

[0084] Following is a description of a production method of the fiber molded body of the present invention. In this invention, a heat-and-humidity molding process indicates a treatment in which heating is performed after a filler-dispersed solution is provided to a fiber structure, or a treatment in which heating is performed while providing the filler-dispersed solution and molding in a predetermined shape is performed. Given as examples of the method of heating are a method of exposure in a heated atmosphere, and a method of causing contact with a heated body. The moisture ratio when providing filler-dispersed solution to the fiber structure is the same as the moisture ratio described above, and so that the explanation is omitted here.

[0085] In the above heat-and-humidity molding process, it is preferable that a resin structure that includes a filler-

dispersed solution is inserted into a pair of metal dies, and a heat pressing treatment is performed. When heating is performed in a state in which moisture is included, the nonwoven fabric itself is stretched moderately and easily follows the shape of the dies, and a deep-draw molded body is obtained easily. When heating is performed while providing the filler-dispersed solution, for example, it is possible to obtain a molded body by inserting a fiber structure into a pair of dies and impregnating with heated water (not less than 90° C.).

[0086] The heat-and-humidity mold processing is performed in a heat-and-humidity atmosphere. It is preferable that the heat-and-humidity mold processing temperature is not less than the gelling temperature of the gelling resin and not more than the melting point minus 20° C. A more preferable heat-and-humidity mold processing temperature is not less than 50° C. A still more preferable heat-and-humidity mold processing temperature is not less than 80° C. On the other hand, a more preferable heat-and-humidity mold processing temperature is not more than the melting point of the heat-and-humidity gelling resin minus 30° C. A still more preferable heat-and-humidity mold processing temperature is not more than the melting point of the heat-and-humidity gelling resin minus 40° C. When the heat-and-humidity mold processing temperature is less than the gelling temperature of the heat-and-humidity gelling resin, it is difficult to form gel material. When the heat-and-humidity mold processing temperature exceeds the melting point of the heat-and-humidity gelling resin minus 20° C., because the temperature is near the melting point of the heat-and-humidity gelling resin, there may be instances in which the molded body is non-uniform.

[0087] In the present invention, when the heat-and-humidity gelling resin is caused to gel under heat and humidity in a heat and humidity atmosphere, it is preferable to produce a fiber molded body by contact press mold processing in a die. The contact press mold processing referred to here means a process in which pressure is applied to the extent that the fiber structure and the die make contact. Contact pressure is pressure applied by the weight of the die itself when the die and the fiber structure are pressed closely together, and is a concept that includes pressure up to this state. Because the heat-and-humidity gelling resin becomes flexible when it is caused to gel under a heat and humidity atmosphere, in the case of simply using a mold, the molding pressure may be not very high. With the contact press mold process, in the fiber molded body the fiber is fixed by the gel material while preserving the form of the fiber, and so a bulky and flexible molded body is obtained. It is sufficient for the die to be, for example, a light and thin die such as a stainless steel plate, or it may be a fine mesh-like die.

[0088] In the present invention, when hardness is sought for the fiber molded body, or film-like material is sought by pressing and spreading the heat-and-humidity gelling resin, it is possible to perform heated press processing at a pressure that produces an ordinary fiber molded body.

[0089] Following is a description of the present invention with reference to the figures. FIGS. 1A to 1C are cross-sectional diagrams of the filler-affixed fiber in an embodiment of the present invention. FIG. 1A shows an example of a conjugate fiber 5 in which polypropylene is used as a core component 2 and ethylene-vinyl alcohol copolymer resin is

used as a sheath component 1. The sheath component 1 functions as binder resin, and a filler 3 is affixed in the sheath component 1. FIG. 1B shows an example of a conjugate fiber 6 in which polypropylene is used as the core component 2 and ethylene-vinyl alcohol copolymer resin is used as the sheath component 1, ethylene-vinyl alcohol copolymer resin is allowed to adhere to the outside of the sheath component 6 as a binder 4, and the filler 3 is mixed into this binder 4. FIG. 1C shows an example in which a polypropylene 8 and an ethylene-vinyl alcohol copolymer resin 7 are multifractionally disposed in a conjugate fiber 9, the ethylene-vinyl alcohol copolymer resin 7 functions as the binder resin, and the filler 3 is affixed at the peripheral portion thereof.

[0090] FIG. 2 is a cross-sectional diagram of a nonwoven fabric with a three-layer structure according to an embodiment of the present invention, and shows an example in which filler-affixed fiber layers 11 are disposed outside, and a rayon fiber layer 12 is disposed inside.

[0091] FIG. 3 is a process diagram of an example of the production method of the present invention. A fiber or nonwoven fabric 31 is impregnated with a filler-dispersed solution 33 that includes a filler or a filler and ethylene-vinyl alcohol copolymer resin in a tank 32, squeezed with a squeeze roll 34, heat-and-humidity treated between a steamer 35 and a vacuum 36, and wound up in that state, or in the case of nonwoven fabric, compression molded by patterning canvas rolls 38 applied to a pair of heat rolls 37 by which a predetermined pattern is provided to the surface of the nonwoven fabric, and afterward, wound by a winder 39. In place of the steamer 35 and the vacuum 36, for example, pressure treatment may be performed for five minutes at a temperature of 150° C. using upper and lower heat plates. As another embodiment, there is also methods in which compression molding is performed with only the pair of heat rolls and without the steamer 35, and in which compression molding is performed with only the patterning canvas rolls 38 applied to the pair of heat rolls 37 and without the steamer 35.

[0092] FIGS. 4A to 4F show a state in which filler is affixed to a nonwoven fabric and its constituent fiber obtained in an example of the present invention. FIG. 4A is a scanning electron microscope plane photograph (magnification 100) that shows the nonwoven fabric, FIG. 4B is a cross-sectional photograph (magnification 100) of the nonwoven fabric in FIG. 4A, FIG. 4C is a fiber surface magnified photograph (magnification 1000) of the surface of the nonwoven fabric in FIG. 4A, FIG. 4D is a scanning electron microscope plane photograph (magnification 100) that shows another portion of the nonwoven fabric in FIG. 4A, FIG. 4E is a cross-sectional photograph (magnification 100) of the portion of nonwoven fabric in FIG. 4D, and FIG. 4F is a fiber surface magnified photograph (magnification 1000) of the surface of the portion of nonwoven fabric in FIG. 4D.

[0093] FIGS. 5A to 5C show a state in which filler is affixed to a nonwoven fabric and its constituent fiber obtained in another embodiment of the present invention. FIG. 5A is a scanning electron microscope plane photograph (magnification 100) that shows the nonwoven fabric. FIG. 5B is a cross-sectional photograph (magnification 100) of the nonwoven fabric in FIG. 5A, and FIG. 5C is a fiber surface magnified photograph (magnification 1000) of the surface of the nonwoven fabric in FIG. 5A.

[0094] FIG. 7 is a process diagram of an example of a production method for a nonwoven fabric including moisture and filler in an embodiment of the fiber molded body of the present invention. The nonwoven fabric 31 is impregnated with the filler-dispersed solution 33 that includes a filler or a filler and ethylene-vinyl alcohol copolymer resin in the tank 32, and squeezed with a squeeze roll 34. Thus, about 500 mass % of moisture and filler are provided to the nonwoven fabric. Next, contact pressure processing is performed in which the nonwoven fabric is fit closely to a metal die made of stainless steel plates with thickness of 0.3 mm and placed in a contact pressure state, inserted in a hot-air dryer with a process temperature of 140° C. and heat treated for 10 minutes. The molded body produces a mask 40 that covers a person's mouth and nose, shown in FIG. 8, and an air cleaner filter 50 processed to have pleats, shown in FIG. 9.

[0095] FIG. 10 is a process diagram of an example of a production method for filler-affixed fiber or nonwoven fabric in another embodiment of the present invention. The fiber or nonwoven fabric 31 is impregnated with a solution 33, which is an aqueous solution that includes a filler (e.g., gas adsorbent particles) or a filler-dispersed solution that includes a filler (e.g., gas adsorbent particles) and ethylene-vinyl alcohol copolymer resin, in a tank 32, squeezed with a squeeze roll 34, steam treated with a steamer 35 that blows out steam from below, dried with a drier 41, and wound up by a winder 39. FIGS. 11A and 11B show a state in which filler is affixed to a nonwoven fabric and its constituent fiber obtained in an embodiment of the present invention. FIG. 11A is a scanning electron microscope plane photograph (magnification 200) that shows the nonwoven fabric, and FIG. 11B is a fiber surface magnified photograph (magnification 2000) of the surface of the nonwoven fabric in FIG. 11A.

EXAMPLES

[0096] Following is a more detailed description using the below examples.

Example 1

[0097] The following was prepared as an abrasive nonwoven fabric.

[0098] (Nonwoven Fabric)

[0099] The below three-layer, hydro-entangled nonwoven fabric was produced.

[0100] The first layer and the third layer were card webs made from core-sheath-type conjugate fiber (fineness: 2.8 dtex, fiber length: 51 mm) with sheath component ethylene-vinyl alcohol copolymer resin (EVOH, ethylene 38 mole %, melting point 176° C.) and core component polypropylene in a 50:50 ratio, and the mass per unit area was set at 30 g/m² for each layer.

[0101] The second layer was a card web made from rayon fiber (fineness: 1.7 dtex, fiber length: 40 mm), and the mass per unit area was set at 30 g/m².

[0102] The mass per unit area of the above three-layer, hydro-entangled nonwoven fabric was 90 g/m². This nonwoven fabric was stacked in the order first layer/second layer/third layer, a 6 MPa high-pressure water stream treatment was performed, and fiber was entangled in the direction of thickness.

[0103] (Filler-Dispersed Solution)

[0104] As filler, a filler-dispersed solution (abrasive solution) was made by suspending "alumina" (average particle diameter 0.7 μm) manufactured by Nippon Light Metal Co. in a ratio of 3 mass %.

[0105] (Provision of Abrasive Solution and Gel Processing)

[0106] The nonwoven fabric was immersed in the abrasive solution, and squeezed with a mangle roll. The pickup rate was regulated to about 500%, and the amount of filler to be affixed was regulated so as to become the numerical values shown in Table 1. The pickup rate is a value obtained by multiplying the sum of the amount of moisture and the amount of filler relative to the mass of the nonwoven fabric by 100. Next, a canvas net was stretched on upper and lower heat plates heated to a temperature of 120° C., the nonwoven fabric was sandwiched between those plates, and gel processing was performed for two seconds at a pressure of 0.064 MPa. Next, drying was performed with heated air at 100° C.

[0107] (Evaluative Testing of Abrasive Properties)

[0108] The below inks were applied to a stainless steel plate and ceramic dish, and after drying removal of stains was performed using each abrasive material. With respect to the removal of stains, rubbing was performed by human hand with the same force for each sample. The ink and evaluation body and points for evaluation were as stated below.

(1) Ink

[0109] A: Oil-based ink (No. 500) made by Teranishi Chemical Industry Co.

[0110] B: Oil-based ink (Artline) made by Shachihata Inc.

[0111] C: Oil-based ink (High Mckee) made by Zebra Co.

[0112] D: Oil-based ink (Mitsubishi Marker Peace) made by Mitsubishi Pencil Co.

[0113] E: Oil-based ink (My Name) made by Sakura Color Products Corp.

(2) Form of Evaluation Body and Abrasive Material

[0114] a: stainless steel plates

[0115] b: ceramic dish

[0116] dry: used in a dry state

[0117] wet: used in a state wetted with water and squeezed

(3) Points for Evaluation

[0118] 6 points: stain disappeared completely by rubbing 5 times

[0119] 5 points: stain disappeared completely by rubbing 10 times

[0120] 4 points: stain disappeared completely by rubbing 20 times

[0121] 3 points: stain disappeared completely by rubbing 30 times

[0122] 2 points: part of the stain slightly remained after rubbing 30 times

[0123] 1 points: about half of the stain remained after rubbing 30 times

[0124] 0 points: nearly all of the stain remained after rubbing 30 times

[0125] Each of the evaluation samples was tested five times. The results of abrasiveness testing were gathered afterward and are shown in Table 1.

[0126] Also, FIGS. 4A to 4F show a state in which filler is affixed to the obtained nonwoven fabric and its constituent fiber.

Comparison Example 1

[0127] The below three-layer, hydro-entangled nonwoven fabric was produced.

[0128] The first layer and the third layer were card webs made from core-sheath type conjugate fiber (fineness: 2.2 dtex, fiber length: 51 mm) with ethylene-vinyl acetate copolymer resin (EVA, melting point 101° C.) and polypropylene in a 50:50 ratio, and the mass per unit area was set at 30 g/m².

[0129] The second layer was a card web made from rayon fiber (fineness: 1.7 dtex, fiber length: 40 mm), and the mass per unit area was set at 30 g/m².

[0130] The mass per unit area of the above three-layer, hydro-entangled nonwoven fabric was 90 g/m². This nonwoven fabric was stacked in the order first layer/second layer/third layer, a 6 MPa high-pressure water stream treatment was performed, and fiber was entangled in the direction of thickness.

[0131] Provision of abrasive agent and other conditions were made the same as in Example 1. The results of abrasiveness testing are gathered and shown in Table 1 below.

Comparison Example 2

[0132] The below three-layer, hydro-entangled nonwoven fabric was produced.

[0133] The first layer and the third layer were card webs made from core-sheath conjugate fiber (fineness: 2.2 dtex, fiber length: 45 mm) with ethylene-methyl acrylate copolymer resin (EMA, melting point 86° C.) and polypropylene in a 50:50 ratio, and the mass per unit area was set at 30 g/m².

[0134] The second layer was a card web made from rayon fiber (fineness: 1.7 dtex, fiber length: 40 mm), and the mass per unit area was set at 30 g/m².

[0135] The mass per unit area of the above three-layer, hydro-entangled nonwoven fabric was 90 g/m². This nonwoven fabric was stacked in the order first layer/second layer/third layer, a 6 MPa high-pressure water stream treatment was performed, and fiber was entangled in the direction of thickness.

[0136] Provision of abrasive agent and other conditions were made the same as in Example 1. The results of abrasiveness testing are gathered and shown in Table 1 below.

[0137] Conventional Product 1

[0138] The same abrasiveness testing as in Example 1 was performed using a commercially available abrasive particle nonwoven fabric scrub brush (made by 3M Co.). The results are gathered and shown in Table 1.

[0139] Conventional Product 2

[0140] The same abrasiveness testing as in Example 1 was performed using a commercially available abrasive particle sponge scrub brush (made by S.T. chemical Co.). The results are gathered and shown in Table 1.

TABLE 1

		Abrabiveness Testing															
Example/ Comparison Example	Affixed Ratio of Alumina (mass %)	A			B			C			D			E			Avg. of All Points
		a dry	a wet	b wet	a dry	a wet	b wet	a dry	a wet	b wet	a dry	a wet	b wet	a dry	a wet	b wet	
Example 1	11	6	6	—	6	6	—	3.2	4.7	—	3.6	6	—	0.4	6	—	5.2
	14	6	6	6	6	6	5.6	3	4.7	6	3.2	6	6	0.6	6	6	
	16	6	6	—	6	6	—	2.8	5	—	3.4	6	—	0.8	6	—	
	18	—	—	5.6	—	—	6	—	—	6	—	—	6	—	—	6	
	Average Points	6	6	5.8	6	6	5.8	3	4.8	6	3.4	6	6	0.6	6	6	
Comparison Example 1	12	3	3	5	0	3	5	0	0	5	0	2.8	5.6	0	3.9	6	3.1
	17	3	2.8	4.8	3.4	3.8	5.4	0	3.4	5	0	3	6	0	3.5	6	
	Average Points	3	2.9	4.9	1.7	3.4	5.2	0	1.7	5	0	2.9	5.8	0	3.7	6	
Comparison Example 2	16	4.3	5	4.7	2	4.7	5.3	0	3	5	0	4.3	6	0	4.3	6	3.6
	Average Points	4.3	5	4.7	2	4.7	5.3	0	3	5	0	4.3	6	0	4.3	6	
Conventional Product 1	Average Points	5.3	6	6	4.3	6	5.7	4	4.3	5.7	3.7	6	6	3.3	5.7	6	5.2
Conventional Product 2	Average Points	6	6	6	6	6	6	3	5	5.3	6	5.7	5.7	2.7	6	6	5.4

[0141] As shown in Table 1, the nonwoven fabric including filler-affixed fiber of the present example has about the same level of abrasiveness as commercially available abrasive material. Additionally, a result of good durability without exfoliation of the filler was obtained for the nonwoven fabric including filler-affixed fiber of the present example. The absence of filler exfoliation is particularly useful for lens and semiconductor abrasives and the like.

Example 2

[0142] (Nonwoven Fabric)

[0143] Hydro-entangled nonwoven fabric (high-pressure water-stream treatment with water pressure 6 MPa) with mass per unit area of 100 g/m² made from the core-sheath-type conjugate fiber of Example 1 was used.

[0144] (Processing Procedure and Conditions)

[0145] The nonwoven fabric was pre-processed by immersing it in an aqueous solution including 0.1 mass % of surfactant (polyoxyethylene alkyl phenol ether for which the carbon number of alkyl groups is 9), and squeezed. Next, it was immersed in an aqueous dispersed solution of ethylene-vinyl alcohol copolymer resin (EVOH) powder (made by Nippon Synthetic Chemical Industry Co., product name "soarnol", powder type B-7, ethylene 29 mole %, melting point 188° C.) and activated carbon (made by Kuraray Chemical Co., product name "Kuraray Coal" PL-D), and squeezed with a mangle roll. Afterward, using a heat plate hydraulic press machine (heating upper and lower heat

Example 3

[0147] Other than using 60 g/m² hydro-entangled nonwoven fabric (water pressure 6 MPa high-pressure water-stream treatment) made from 1.7 dtex, 51 mm rayon fiber, the same treatment as in Example 2 was performed.

[0148] The activated carbon was affixed strongly and uniformly. The results of the obtained filler-affixed nonwoven fabric are gathered and shown in Table 2.

Example 4

[0149] Other than using 60 g/m² hydro-entangled nonwoven fabric (water pressure 6 MPa high-pressure water-stream treatment) made from 1.7 dtex, 51 mm polyester fiber, the same treatment as in Example 2 was performed.

[0150] The activated carbon was affixed strongly and uniformly. The results of the obtained filler-affixed nonwoven fabric are gathered and shown in Table 2.

Example 5

[0151] Other than using 50 g/m² hydro-entangled nonwoven fabric (water pressure 6 MPa high-pressure water-stream treatment) made from 1.7 dtex, 51 mm polypropylene fiber, the same treatment as in Example 2 was performed.

[0152] The activated carbon was affixed strongly and uniformly. The results of the obtained filler-affixed nonwoven fabric are gathered and shown in Table 2.

TABLE 2

Example No.	Dispersed Solution of EVOH Powder + Activated Carbon			Activated		
	EVOH Powder Quantity (mass %)	Activated Carbon Quantity (mass %)	Pickup Rate (mass %)	Total Affixing Rate (mass %)	EVOH Affixing Rate (mass %)	Carbon Affixing Rate (mass %)
Example 2	1	5	425	63	11	52
	3	5	500	77	29	48
	3	10	498	85	20	65
Example 3	1	5	452	52	9	43
	3	5	565	94	35	59
	3	10	550	96	22	74
Example 4	1	5	556	67	11	56
	3	5	820	165	62	103
	3	10	575	105	24	81
Example 5	1	5	572	67	11	56
	3	5	688	106	40	66
	3	10	622	117	27	90

plates), the nonwoven fabric was sandwiched between canvas nets and gel processing was performed. The heating temperature was 120° C., pressing pressure was 0.032 MPa, and the heating time was 2 minutes. Surplus filler was washed away, and drying was performed with 100° C. heated air.

[0146] The activated carbon was affixed strongly and uniformly. The results of the obtained nonwoven fabric including filler-affixed fiber are gathered and shown in Table 2.

Example 6

[0153] The first layer and the third layer were card webs made from splittable conjugate fiber (fineness: 3.3 dtex, fiber length: 51 mm) with the ethylene-vinyl alcohol copolymer resin (EVOH) of Example 1 and the polypropylene of Example 1 in a 50:50 ratio, and the mass per unit area was set at 30 g/m² for each layer. The second layer between the first layer and the third layer was a card web in which the rayon fiber of Example 1 and polyester fiber (fineness: 1.7 dtex, fiber length: 51 mm) were mixed 1:1, and the mass per unit area was set at 30 g/m². Using the same method as in

Example 1, hydro-entangled nonwoven fabric was made, and gel processing was performed. Filler was affixed strongly and uniformly in the same manner as Example 1. FIGS. 5A to 5C show a state in which filler is affixed to the obtained nonwoven fabric and its constituent fiber.

Example 7

[0154] (Production of Nonwoven Fabric)

[0155] Core-sheath-type conjugate fiber (fineness: 3.3 dtex, fiber length 51 mm) was prepared in which the sheath component was ethylene-vinyl alcohol copolymer resin (EVOH, quantity of ethylene included 38 mole %, melting point 176° C.), the core component was polypropylene (PP, melting point 161° C.), and the ratio of EVOH:PP was 50:50 (volumetric specific). Also, heat-and-dryness adhering conjugate fiber (made by Daiwabo Co., NBF (H)) with fineness 2.2 dtex and fiber length 51 mm was prepared in which the sheath component was polyethylene (PE: melting point 132° C.), and the core component was polypropylene (PP: melting point 161° C.).

[0156] 75 mass % of the core-sheath-type conjugate fiber and 25 mass % of the heat-and-dryness adhering fiber were mixed, fiber was opened with a semi-random carding machine, and a card web with mass per unit area of 45 g/m² was produced. Next, the card web was placed on a 90 mesh flat-woven support, and after a water stream was applied toward the card web with a water pressure of 3 MPa from a nozzle in which orifices (diameter 0.12 mm, pitch 0.6 mm) were disposed in a line in the widthwise direction of the card web, a water stream with a water pressure of 4 MPa also was applied. Next, the card web was reversed, and a water stream with a water pressure of 4 MPa was applied from the nozzle, producing a hydro-entangled nonwoven fabric.

[0157] (Filler Preparation)

[0158] As filler, activated carbon: "Taiko SA1000" (made by Futamura Chemical Co., average particle diameter 10 μm) was used.

[0159] (Production of Nonwoven Fabric Including Filler-Affixed Fiber)

[0160] The above nonwoven fabric was immersed in a filler-dispersed solution (20° C.) in which 8 mass % of the activated carbon particles had been dispersed in water, and the pickup rate was regulated with a squeezing pressure of linear pressure about 60 N/cm using the mangle roll. Next, steam treatment was performed on the nonwoven fabric, which had been immersed in the filler-dispersed solution, for 15 seconds at an inner chamber temperature of 102° C. using a steamer blowing out steam from the bottom portion of the nonwoven fabric, and the nonwoven fabric was dried with a heated-air drier (100° C.), obtaining the nonwoven fabric of the present invention. The mass per unit area of the nonwoven fabric was 68 g/m² and about 23 g/m² of filler were affixed. FIGS. 11A and 11B show a state in which filler is affixed to the obtained nonwoven fabric and its constituent fiber. In the obtained nonwoven fabric, filler was affixed to the fiber surface in an exposed state, and the fiber form was preserved.

Examples 8 to 11

[0161] The following was prepared as gas adsorbent material.

[0162] (Production of Nonwoven Fabric)

[0163] Core-sheath-type conjugate fiber (fineness: 2.8 dtex, fiber length 51 mm) was prepared in which the sheath component was ethylene-vinyl alcohol copolymer resin (EVOH, quantity of ethylene included 38 mole %, melting point 176° C.), the core component was polypropylene (PP, melting point 161° C.), and the ratio of EVOH:PP was 50:50 (volumetric specific).

[0164] The core-sheath-type conjugate fiber was opened with a semi-random carding machine, and a card web having the mass per unit area shown in Table 3 was produced. Next, the card web was placed on a 90 mesh flat-woven support, and after a water stream was applied toward the card web with a water pressure of 3 MPa from a nozzle in which orifices (diameter 0.12 mm, pitch 0.6 mm) were disposed in a line in the widthwise direction of the card web, a water stream with a water pressure of 4 MPa was also applied. Next, the card web was reversed, and a water stream with a water pressure of 4 MPa was applied from the nozzle, producing the hydro-entangled nonwoven fabric used in Examples 8 to 11.

[0165] (Filler Preparation)

[0166] Gas adsorbent particles were prepared as filler. As the gas adsorbent particles, activated carbon particles: "Kuraray Coal PL-D" (made by Kuraray Chemical Co., coconut activated carbon, average particle diameter 40 to 50 μm) was used.

[0167] (Production of Nonwoven Fabric Including Filler-Affixed Fiber)

[0168] The above nonwoven fabric was immersed in a filler-dispersed solution (20° C.) in which 10 mass % of the activated carbon particles had been dispersed in water, the pickup rate was regulated with the mangle roll squeezing pressure, and the affixed amount of the activated carbon particles was regulated so as to be the numerical values shown in Table 3. The pickup rate is a value obtained by multiplying the sum of the amount of moisture and the amount of activated carbon particles relative to the mass of the nonwoven fabric by 100. Next, the nonwoven fabric that had been immersed in the filler-dispersed solution was sandwiched between two sheets of flat-woven plastic net (length 40 cm×width 40 cm) with line diameter 0.3 mm, mesh number: length 30/inch×width 25/inch, and placed on a hot plate heated to 150° C., and heat-and-humidity treatment was performed for 15 minutes with the plastic net of the top side covered by an aluminum sheet (1 g/m²). The obtained nonwoven fabric was rinsed with water and dried with a heated-air drier (100° C.), obtaining the nonwoven fabric (gas adsorbent material) of the present invention.

Example 12

[0169] After the same nonwoven fabric as the hydro-entangled nonwoven fabric used in Example 8 was immersed for 30 seconds in filler-dispersed solution (95° C.) in which 5 mass % of the activated carbon particles had been dispersed in water, it was removed. Then, the nonwoven fabric was hung until its temperature reached 50° C. After-

wards, the nonwoven fabric was rinsed with water and dried with a heated-air drier (100° C.), obtaining the nonwoven fabric (gas adsorbent material) of the present invention.

[0170] Table 3 shows the mass per unit area of the nonwoven fabric, affixed quantity of the activated carbon particles, affixed ratio of activated carbon particles, and mass per unit area of the nonwoven fabric (gas adsorbent material) for the nonwoven fabric (gas adsorbent material) of Examples 8 to 12.

TABLE 3

Example No.	Mass Per Unit Area of Nonwoven Fabric (g/m ²)	Affixed Quantity of Activated Carbon Particles (g/m ²)	Affixed Ratio of Activated Carbon Particles (mass %)	Mass Per Unit Area of Nonwoven Fabric (Gas Adsorbent Material) (g/m ²)
8	113	159	141	272
9	114	98	86	212
10	110	114	104	224
11	41	43	105	84
12	113	27	24	140

Comparison Example 3

[0171] A filler-dispersed solution was prepared including 15 mass % of self-cross-linking ester acrylate emulsion (made by Nippon Carbide Industries Co., product name “Nicasole FX-555A”) and 10 mass % of the activated carbon particles. Next, the same nonwoven fabric as the hydro-entangled nonwoven fabric used in Example 8 was immersed in the solution, squeezed with a mangle roll, dried

activated carbon particles were fixed with hot-melt adhesive between two sheets of spunbond nonwoven fabric with deodorant fixed to the surface.

[0173] VOC Gas Adsorption Testing Method

[0174] The sheets in Examples 8 to 12 and Comparison Examples 3 and 4 were cut to a size of 10 cm long×10 cm wide and placed in a pollution analysis bag (product name “Tedlarbag”) with a volume of 5 liters, and each VOC gas

mixed with air so as to have the initial concentration shown in Tables 4 to 6 was injected. The time of injection was regarded as the start time, and the concentration of each VOC gas in the bag was measured with a gas detection tube per when a designated amount of time passed. The results are shown in Tables 4 to 6. In Tables 4 to 6, “ND” indicates the case in which the concentration of each VOC gas had become less than the measurement limit (2 ppm) of the gas detection tube that was used.

TABLE 4

		Initial Concentration	After 30 Min.	After 1 Hour	After 3 Hours	After 6 Hours
Formaldehyde remaining concentration (ppm)	Example 8	100	4	3	2	2
	Example 12	100	9	8	—	—
	Comparison Example 3	20	3	3	—	—
	Comparison Example 3	100	10	8	7	7

for 15 minutes at a temperature of 140° C. using a heated-air drier and hardened, obtaining a chemical bond nonwoven fabric with an affixed quantity of activated carbon particles of 38 g/m².

Comparison Example 4

[0172] As comparison example 4, a VOC gas adsorbent sheet (made by Asahi Kasei Fibers, product name “Semia V”, mass per unit area g/m², affixed amount of activated carbon particles about 40 g/m²) was prepared in which

[0175]

TABLE 5

		Initial Concentration	After 5 Min.	After 30 Min.	After 1 Hour
Toluene remaining concentration (ppm)	Example 9	20	10	2	ND
	Example 12	23	4	ND	ND
	Comparison Example 4	20	11	4	ND
Xylene	Example 9	24	11	ND	ND

TABLE 5-continued

		Initial Concen- tration	After 5 Min.	After 30 Min.	After 1 Hour
remaining	Example 12	24	5	ND	ND
concentration	Comparison	24	15	5	ND
(ppm)	Example 4				
Paradichloro	Example 9	28	6	ND	ND
benzene	Example 12	20	5	ND	ND
remaining	Comparison	28	18	ND	ND
concentration	Example 4				
(ppm)					

[0176]

TABLE 6

		Initial Concen- tration	After 5 Min.	After 30 Min.	After 1 Hour
Ethylbenzene	Example 10	20	6	1	ND
remaining	Example 11	20	6	1	ND
concentration	Example 12	20	3	ND	ND
(ppm)	Comparison	20	8	1.5	ND
	Example 4				
Styrene	Example 10	22	4	2	2
remaining	Example 11	22	6	3	2
concentration	Example 12	24	4	2	2
(ppm)	Comparison	22	10	3	3
	Example 4				

[0177] Results

[0178] As shown in Tables 4 to 6, when using the nonwoven fabric of Examples 8 to 11, in comparison to Comparison Examples 3 and 4, the speed of decrease in the concentration of each VOC gas is fast, and gas adsorption performance is improved. And, as shown in Table 4, with respect to Example 12, despite the fact that the amount of affixed activated carbon particles is less than in the case of Comparison Example 3, formaldehyde-adsorbing performance equivalent to that of Comparison Example 3 is shown. Further, as shown in Tables 5 and 6, with respect to Example 12, despite the fact that the amount of affixed activated carbon particles is less than in the case of Comparison Example 4, gas adsorption performance is improved. This is thought to be due to the fact that because the activated carbon particles (gas adsorbent particles) in the nonwoven fabric of Examples 8 to 12 are affixed by gel material that has been caused to gel under heat and humidity on the fiber surface, the gas adsorbent particles are affixed in a state exposed to the surface, and so in comparison to Comparison Examples 3 and 4, a decrease in the relative surface area of the gas adsorbent particles has been suppressed. Also, in the nonwoven fabric of Examples 8 to 12, the fiber form is preserved, and so there was no shrinkage of the nonwoven fabric when gel processing was performed. Additionally, with the nonwoven fabric of Examples 8 to 12, there was no exfoliation of the gas adsorbent particles.

Example 13

[0179] The following was prepared as water purifier.

[0180] (Production of Nonwoven Fabric)

[0181] Core-sheath-type conjugate fiber (fineness: 2.8 dtex, fiber length 51 mm) was prepared in which the sheath component was ethylene-vinyl alcohol copolymer resin (EVOH, quantity of ethylene included 38 mole %, melting point 176° C.), the core component was polypropylene (PP, melting point 161° C.), and the ratio of EVOH:PP was 50:50 (volumetric specific).

[0182] The core-sheath-type conjugate fiber was carded with a semi-random carding machine, and a card web having a mass per unit area of 101 g/m² was produced. Next, the card web was placed on a 90 mesh flat-woven support, and after a water stream was applied toward the card web with a water pressure of 3 MPa from a nozzle in which orifices (diameter 0.12 mm, pitch 0.6mm) were disposed in a line in the widthwise direction of the card web, a water stream with a water pressure of 4 MPa was also applied. Next, the card web was reversed, and a water stream with a water pressure of 4 MPa was applied from the nozzle, producing the hydro-entangled nonwoven fabric used in Example 1.

[0183] (Filler Preparation)

[0184] Organic matter adsorbent particles were prepared as filler. As the organic matter adsorbent particles, activated carbon particles: "Kuraray Coal PL-D" (made by Kuraray Chemical Co., coconut activated carbon, average particle diameter 40 to 50 μm) were used.

[0185] (Production of Nonwoven Fabric Including Filler-Affixed Fiber)

[0186] The above nonwoven fabric was immersed in a filler-dispersed solution (20° C.) in which 10 mass % of the activated carbon particles had been dispersed in water, the pickup rate was regulated with the mangle roll squeezing pressure, and the affixed amount of the activated carbon particles was regulated so as to be the numerical values shown in Table 7. Next, the nonwoven fabric that had been immersed in the filler-dispersed solution was held sandwiched between two sheets of flat-woven plastic net (length 40 cm×width 40 cm) with line diameter 0.3 mm, mesh number: length 30/inch×width 25/inch, and placed on a hot plate heated to 150° C., and heat-and-humidity treatment was performed for 15 minutes with the plastic net of the top side covered by an aluminum sheet (1 g/m²). The obtained nonwoven fabric was rinsed with water and dried with a heated-air drier (100° C.), obtaining the nonwoven fabric (water purifying material) of the present invention.

Example 14

[0187] Other than using a card web with a mass per unit area of 40 g/m², the concentration of the activated carbon particles in the water-dispersed solution when affixing the activated carbon particles was set at 5 mass %, regulating the pickup rate with a mangle roll and regulating the affixed amount of the activated carbon particles so as to be the numerical values shown in Table 1, the nonwoven fabric (water purifying material) of the present invention was obtained by the same method as in Example 13.

[0188] Table 7 shows the mass per unit area of the nonwoven fabric, the affixed quantity of activated carbon

particles, the affixed ratio of activated carbon particles, and the mass per unit area of the nonwoven fabric (water purifying material) for the nonwoven fabric (water purifying material) of Examples 13 and 14. In the nonwoven fabric of Examples 13 and 14 the fiber form was preserved, and there was no shrinkage of the nonwoven fabric when gel processing was performed.

TABLE 7

Example No.	Mass per unit area of nonwoven fabric (g/m ²)	Affixed Quantity of Activated Carbon Particles (g/m ²)	Affixed Ratio of Activated Carbon Particles (mass %)	Mass Per Unit Area of Nonwoven Fabric (Water Purifying Material) (g/m ²)
13	101	90	89	191
14	40	20	50	60

Comparison Example 5

[0189] As comparison example 5, activated carbon fiber nonwoven fabric (made by Kuraray Co., product name "Kuractive", mass per unit area about 180 g/m²) was prepared.

[0190] Method of Testing Water Purification Performance

[0191] With respect to Examples 13 and 14 and Comparison Examples 3 and 5, water purification performance was tested with the water-circulating small-scale testing apparatus shown in FIG. 6. As shown in FIG. 6, a water-circulating small-scale testing apparatus 20 is provided with a stand 21, fixed jigs 22a and 22b attached to the stand 21, a dosed, cylindrical container 23 fixed to the stand 21 by the fixed jig 22a, and a pump 24 that circulates water in the container 23. The pump 24 includes a tube 24a attached to an opening 23a of the floor portion of the container 23 and a tube 24b fixed to the stand 21 by the fixed jig 22b. Water inside the container 23 is sucked by the tube 24a from the opening 23a of the container 23, and the sucked water is discharged to the upper portion of the container 23 by the tube 24b. With respect to Example 13 and Comparison Example 5, the present testing was performed by placing industrial waste water with a chemical oxygen demand (COD) of 40 ppm in the container 23, and with respect to Example 14 and Comparison Example 3, testing was performed by using industrial waste water with a COD of 20 ppm. Also, with a power conditioning unit (not shown) connected to the pump 24, the water circulation flow rate was set at 6 liters per minute, and during testing, a liquid volume of 1 liter was preserved for the industrial waste water in the container 23.

[0192] Production Method of Testing Sample

[0193] The nonwoven fabric of Examples 13 and 14 and Comparison Examples 3 and 5 was cut into 3 cm×3 cm scraps 25 (see FIG. 6). Next, with respect to each of Examples 13 and 14 and Comparison Examples 3 and 5, a testing sample 27 (see FIG. 6) was produced by weighing the small scraps 25 such that the quantity of activated carbon became 10 g, and placing the weighed small scraps 25 in a commercially available tea bag 26 (see FIG. 6). When performing water purification performance testing, as shown in FIG. 6, the testing sample 27 was immersed in the industrial waste water in the container 23, and fixed to the fixed jig 22b by a wire 28.

[0194] Method of Measuring COD Concentration

[0195] The COD concentration was measured by extracting the industrial waste water in the container 23 to a beaker with a dropper at each measurement time, and comparing to a reference color with a small-scale water analysis product "Pack Test" (WAK-COD, measurement range 0 to 100 mg

per liter) made by Kyoritsu Chemical-Check Lab. Co. The results are shown in Table 8.

TABLE 8

	COD Concentration (ppm)					
	Initial Concentration	After 10 Min.	After 15 Min.	After 30 Min.	After 60 Min.	After 120 min.
Example 13	40	30	30	28	16	—
Example 14	20	—	20	13	13	10
Comparison Example 3	20	—	20	20	20	20
Comparison Example 5	40	35	30	30	18	—

[0196] Results

[0197] As shown in Table 8, when the nonwoven fabric of Examples 13 and 14 was used, the speed of the decrease in COD concentration was faster than in Comparison Examples 3 and 5, indicating good water purification performance. Particularly, water purification performance was improved after 120 minutes from the start of measurement, with the COD concentration of Example 14 being about half the COD concentration of Comparison Example 3. This is thought to be due to the fact that because the activated carbon particles (organic matter adsorbent particles) in the nonwoven fabric of Example 14 are affixed by gel material that has been caused to gel under heat and humidity on the fiber surface, the organic matter adsorbent particles are affixed in a state exposed to the surface, and so in comparison to Comparison Example 3, a decrease in the specific surface area of the organic matter adsorbent particles has been suppressed.

[0198] Activated Carbon Exfoliation Rate

[0199] The exfoliation rate of the activated carbon was measured using the method described below with respect to Example 14 and Comparison Example 5.

[0200] The nonwoven fabric in both Example 14 and Comparison Example 5 was cut so that the amount of activated carbon became 1.21 g. The size of the cut samples was 30 cm×20 cm in Example 14 and 6.6 cm×10 cm in Comparison Example 5. Next, 2 liters of water were placed in a 3 liter beaker, the samples of Example 13 and Com-

parison Example 5 each were placed in the water in the beaker, and this was stirred for 4 hours in a magnetic stirrer. Afterwards, the samples were removed and suction filtered using a glass filter paper (made by Toyo Roshi Co., product name "Advantech", item no. "Glass Fiber GS25", diameter 47 mm) whose mass was measured in advance, and after drying the filtered glass filter paper, the mass of the dried glass filter paper was measured. From the mass of the obtained glass filter paper, the quantity and rate of exfoliation of activated carbon was obtained. The exfoliation quantity of activated carbon is a value obtained by decreasing the mass of the glass filter paper prior to filtering from the mass of the glass filter paper after drying. The exfoliation rate of the activated carbon is a value obtained by dividing the exfoliation quantity of activated carbon by the quantity of carbon before testing (1.21 g), and multiplying that result by 100. Results are shown in Table 9.

TABLE 9

	Activated Carbon Quantity (g)	Exfoliation Quantity (g)	Exfoliation Rate (%)
Example 14	1.21	0.0016	0.13
Comparison Example 5	1.21	0.0201	1.66

[0201] Results

[0202] As shown in Table 9, with the nonwoven fabric of Example 14 it was possible to suppress the exfoliation quantity and rate of activated carbon in comparison to Comparison Example 5. This is thought to be due to the fact that because the activated carbon (activated carbon particles) in the nonwoven fabric of Example 14 are affixed by gel material that has been caused to gel under heat and humidity on the fiber surface, the activated carbon can be held more strongly in comparison to Comparison Example 5.

Example 15

[0203] (Production of Nonwoven Fabric)

[0204] Core-sheath-type conjugate fiber (fineness: 2.8 dtex, fiber length 51 mm) was prepared in which the sheath component was ethylene-vinyl alcohol copolymer resin (EVOH, quantity of ethylene included 38 mole %, melting point 176° C.), the core component was polypropylene (PP, melting point 161° C.), and the ratio of EVOH:PP was 50:50 (volumetric specific).

[0205] The core-sheath-type conjugate fiber was carded with a semi-random carding machine, and a card web having a mass per unit area of 40 g/m² was produced. Next, the card web was placed on a 90 mesh flat-woven support, and after a water stream was applied toward the card web with a water pressure of 3 MPa from a nozzle in which orifices (diameter 0.12 mm, pitch 0.6 mm) were disposed in a line in the widthwise direction of the card web, a water stream with a water pressure of 4 MPa was also applied. Next, the card web was reversed, and a water stream with a water pressure of 4 MPa was applied from the nozzle, producing a hydro-entangled nonwoven fabric.

[0206] (Filler Preparation)

[0207] As filler, activated carbon particles: "Kuraray Coal PL-D" (made by Kuraray Chemical Co., coconut activated carbon, average particle diameter 40 to 50 μm) were used.

[0208] (Filler-Affixed Heat-and-Humidity Mold Processing)

[0209] The above nonwoven fabric was immersed in a filler-dispersed solution (20° C.) in which 10 mass % of the activated carbon particles had been dispersed in water, and the pickup rate was regulated with the mangle roll squeezing pressure.

[0210] The nonwoven fabric including moisture and filler was sandwiched and closely fit between a pair of metal dies made of stainless steel plates with a thickness of 0.3 mm, inserted in a heated-air drier with a process temperature of 140° C. and heat treated with contact pressure for 10 minutes. The molded body produced the mask 40 that covers a person's mouth and nose shown in FIG. 8 using a bowl-shaped metal die, and the air purification filter processed to have pleats shown in FIG. 9 using a pleated-type metal die. When calculating the affixing rate of the activated carbon particles of the obtained mask and the filter processed to have pleats, both were about 100 mass %.

[0211] The mask shown in FIG. 8 had a moderate amount of flexibility, preserved the fiber form, and was a deep-draw bowl-shaped molded body in which fiber was uniformly dispersed. The activated carbon particles fixed by gel material did not exfoliate from the molded body. Even when the mask was worn, there was no sensation of breathing difficulty. As for the filter processed to have pleats in FIG. 9, the fiber form was preserved, fiber was uniformly dispersed, and the filter was a deep-draw molded body with clear mountains and valleys (creases). The activated carbon particles fixed by gel material did not exfoliate from the molded body. Because the filter processed to have pleats in FIG. 9 was well folded, it had good processability into a pleated-type cartridge filter.

[0212] With the present invention, it is possible to provide a filler-affixed fiber, a fiber structure, and a fiber molded body, and a method for producing the same, with which the functions possessed by the filler can be exhibited effectively while preserving the inherent fiber qualities.

[0213] In the present invention, because the filler is affixed to the fiber surface by gel material, the filler does not easily exfoliate, and the filler can be affixed in a state exposed to the fiber surface. For example, when the fiber structure of the present invention is used as gas adsorbent material, because the gas adsorbent particles are affixed by gel material on the fiber surface, the gas adsorbent particles can be affixed in a state exposed to the surface. Thus, exfoliation of the gas adsorbent particles affixed to the fiber surface is prevented, and a decrease in the specific surface area of the gas adsorbent particles can be suppressed, and therefore it is possible to improve gas adsorbent performance in comparison to conventional gas adsorbent material. Also, when the fiber structure of the present invention is used as water purifying material, because the organic matter adsorbent particles are affixed by gel material on the fiber surface, the organic matter adsorbent particles can be affixed in a state exposed to the surface. Thus, exfoliation of the organic matter adsorbent particles affixed to the fiber surface is prevented, and a decrease in the relative surface area of the organic matter adsorbent particles can be suppressed, and therefore it is possible to improve purifying performance in comparison to conventional water purifying material.

[0214] In the fiber molded body of the present invention, the binder resin includes heat-and-humidity gelling resin,

and in the fiber structure, the fiber is fixed by gel material in which the heat-and-humidity gelling resin has been caused to gel under heat and humidity, and by being molded in a predetermined shape, in the case of clothing applications, the material is soft even when making direct or indirect contact with a person's skin. Also, the mold is uniform, so that a deep-draw shape can be obtained. Further, it is possible to effectively affix filler to the fiber surface.

[0215] With the production method of the fiber molded body of the present invention, a fiber aggregate including fiber and heat-and-humidity gelling resin is molded, and by heat-and-humidity mold processing, uniform molding can be performed, and a deep-draw shape can also be molded easily. Molding cost can be made inexpensive even in ordinary applications.

INDUSTRIAL APPLICABILITY

[0216] The filler-affixed fiber and fiber structure of the present invention is useful for, for example, filament fibers that polish between teeth (dental floss), as abrasive material for industrial use, abrasive materials of various fields such as lenses, semiconductors, metals, plastics, ceramics, and glass, abrasive materials used in home or industrial kitchens or the like, gas adsorbent materials that adsorb harmful gas or the like, antibacterial materials, deodorants, ion-exchanging materials, sewage processing materials, oil adsorbent materials, metal adsorbent materials, nonwoven materials for battery separator, conductive materials, antistatic materials (charging prevention), humidity controlling materials, dehumidifying materials (condensation prevention), sound absorbing/preventing materials, insect repellent, mold-preventing materials, and antiviral materials. For example, gas adsorbent materials and antiviral materials can be used for building material protective sheets, wallpapers, masks, and filters for air conditioners and the like.

[0217] The fiber molded body of the present invention, in the case of clothing applications, for example, can be used for shoulder pads, breast pads, jacket collar interlinings, sleeve interlinings, pocket interlinings, front and rear panels, facing material, trouser waist/hip interlinings, and the like. Also, in the case of non-clothing applications, for example, it can be molded in various shapes such as masks, pleated filter elements used in air purifiers and dean rooms, heat insulating material in air conditioner air ducts, plumbing, pipes, plates, and sheets having an uneven pattern with a calendered surface.

1. A filler-affixed fiber comprising a fiber, a binder resin on the fiber surface, and a filler affixed to the binder resin, wherein

the binder resin is heat-and-humidity gelling resin that is caused to gel by heating in the presence of moisture, and

the filler is affixed by a gel material produced by causing the heat-and-humidity gelling resin to gel.

2. The filler-affixed fiber according to claim 1, wherein the heat-and-humidity gelling resin is ethylene-vinyl alcohol copolymer resin.

3. The filler-affixed fiber according to claim 1, wherein the average particle diameter of the filler is in a range of 0.01 to 100 μm .

4. A fiber structure comprising a filler-affixed fiber including a fiber, a binder resin on the fiber surface, and a filler affixed to the binder resin, wherein

the binder resin is heat-and-humidity gelling resin that is caused to gel by heating in the presence of moisture, and

the filler is affixed by a gel material produced by causing the heat-and-humidity gelling resin to gel.

5. The fiber structure according to claim 4, wherein the heat-and-humidity gelling resin is ethylene-vinyl alcohol copolymer resin.

6. The fiber structure according to claim 4, wherein the fiber and the binder resin have at least one combination selected from among

(I) conjugate fiber that includes a heat-and-humidity gelling resin component and another thermoplastic synthetic fiber component,

(II) a mixture of the conjugate fiber and another fiber,

(III) a mixture of the conjugate fiber and heat-and-humidity gelling resin, and

(IV) a mixture of heat-and-humidity gelling resin and another fiber.

7. The fiber structure according to claim 4, wherein the average particle diameter of the filler is in a range of 0.01 to 100 μm .

8. The fiber structure according to claim 4, wherein the filler is inorganic particles.

9. The fiber structure according to claim 8, wherein the inorganic particles are at least one selected from alumina, silica, tripoli, diamond, corundum, emery, garnet, flint, synthetic diamond, boron nitride, silicon carbide, boron carbide, chrome oxide, cerium oxide, iron oxide, colloid silicate, carbon, graphite, zeolite, titanium dioxide, kaolin, clay, and silica gel.

10. The fiber structure according to claim 9, wherein the filler is an abrasive, and the fiber structure is an abrasive nonwoven fabric.

11. The fiber structure according to claim 4, wherein the filler includes porous particles.

12. The fiber structure according to claim 11, wherein the porous particles are activated carbon particles.

13. The fiber structure according to claim 12, wherein the fiber structure is in the form of gas adsorbent material.

14. The fiber structure according to claim 12, wherein the fiber structure is in the form of water purifying material.

15. The fiber structure according to claim 4, wherein the filler-affixed fiber is present on both surfaces, and hydrophilic fiber is present inside.

16. The fiber structure according to claim 15, wherein the hydrophilic fiber is at least one fiber selected from rayon fiber, cotton fiber, and pulp.

17. The fiber structure according to claim 4, wherein the fiber structure is compression molded and affixed in the direction of thickness.

18. A fiber molded body made by molding a fiber structure including a fiber, a binder resin on the fiber surface, and a filler-affixed fiber affixed to the binder resin, wherein

the binder resin includes heat-and-humidity gelling resin that is caused to gel by heating in the presence of moisture, and

in the fiber structure, the fiber is fixed by a gel material produced by causing the heat-and-humidity gelling resin to gel under heat and humidity, and the fiber structure is molded in a predetermined shape.

19. The fiber molded body according to claim 18, wherein the fiber molded body is molded by contact pressure mold processing.

20. A method for producing a filler-affixed fiber including a fiber, a binder resin on the fiber surface, and a filler affixed to the binder resin, wherein

the fiber and the binder resin are heat-and-humidity gelling fiber that is caused to gel by heating in the presence of moisture,

a filler-dispersed solution in which the filler is dispersed in a solution is provided to the heat-and-humidity gelling fiber, and

next, the heat-and-humidity gelling fiber is caused to gel by performing heat-and-humidity treatment on the heat-and-humidity gelling fiber in a heat and humidity atmosphere, so that the filler is affixed to the fiber surface by gel material.

21. The method for producing a filler-affixed fiber according to claim 20, wherein the heat-and-humidity gelling fiber is conjugate fiber that includes heat-and-humidity gelling resin alone, or a heat-and-humidity gelling resin component and another thermoplastic synthetic fiber component.

22. The method for producing a filler-affixed fiber according to claim 20, wherein the heat and humidity atmosphere has a temperature range from not less than the gelling temperature of the heat-and-humidity gelling resin to not more than the melting point minus 20° C.

23. A method for producing a filler-affixed fiber including a fiber, a binder resin on the fiber surface, and a filler affixed to the binder resin, wherein

the fiber and the binder resin are another fiber and heat-and-humidity gelling resin,

filler is provided after the heat-and-humidity gelling resin has been provided to the other fiber, or a filler-dispersed solution in which the filler and the heat-and-humidity gelling resin are dispersed in a solution is provided to the other fiber, and

next, the heat-and-humidity gelling resin is caused to gel by performing heat-and-humidity treatment in a heat and humidity atmosphere, and the filler is affixed to the surface of the other fiber by gel material.

24. A method for producing a fiber structure containing a filler-affixed fiber including a fiber, a binder resin on the fiber surface, and a filler affixed to the binder resin, wherein

the binder resin is heat-and-humidity gelling resin that is caused to gel by heating in the presence of moisture,

the fiber and the binder resin are at least one combination selected from among

(I) conjugate fiber that includes a heat-and-humidity gelling resin fiber component and another thermoplastic synthetic fiber component,

(II) a mixture of the conjugate fiber and another fiber,

(III) a mixture of the conjugate fiber and heat-and-humidity gelling resin, and

(IV) a mixture of heat-and-humidity gelling resin and another fiber,

a fiber structure is produced with the fiber and the binder resin,

a filler-dispersed solution in which the filler is dispersed in a solution is provided to the fiber structure, and

next, the heat-and-humidity gelling resin is caused to gel by performing heat-and-humidity treatment on the heat-and-humidity gelling resin in a heat and humidity atmosphere, so that the filler is affixed to the fiber surface by gel material, forming a filler-affixed fiber.

25. The method for producing a fiber structure according to claim 24, wherein the heat and humidity atmosphere has a temperature range from not less than the gelling temperature of the heat-and-humidity gelling resin to not more than the melting point minus 20° C.

26. The method for producing a fiber structure according to claim 24, wherein the heat-and-humidity treatment is a treatment of performing compression molding in the direction of thickness.

27. The method for producing a fiber structure according to claim 24, wherein the heat-and-humidity treatment is a treatment performed with steam.

28. The method for producing a fiber structure according to claim 24, wherein the filler-dispersed solution is an aqueous solution or an aqueous solution that includes a heat-and-humidity gelling resin.

29. A method for producing a fiber molded body made by molding a fiber structure including a fiber, a binder resin on the fiber surface, and a filler-affixed fiber affixed to the binder resin, wherein

the binder resin includes heat-and-humidity gelling resin that is caused to gel by heating in the presence of moisture,

a fiber structure including the fiber and the binder resin is produced, and

heat-and-humidity mold processing is performed on the fiber structure in a metal die by causing the heat-and-humidity gelling resin to gel under heat and humidity in a heat and humidity atmosphere.

30. The method for producing a fiber molded body according to claim 29, wherein the heat-and-humidity mold processing is processing in which a fiber structure that includes moisture and filler is inserted into a pair of metal dies, and a heat-and-pressure treatment is performed.

31. The method for producing a fiber molded body according to claim 29, wherein the heat-and-humidity mold processing is contact pressure mold processing in which processing is performed with a pressure at which the fiber structure and the metal dies make contact.

* * * * *