

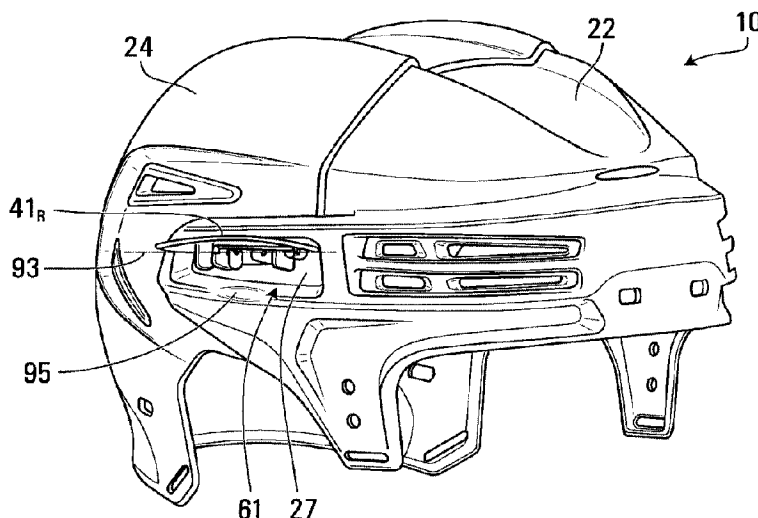

(22) Date de dépôt/Filing Date: 2016/09/20
(41) Mise à la disp. pub./Open to Public Insp.: 2017/03/20
(45) Date de délivrance/Issue Date: 2023/10/03
(30) Priorité/Priority: 2015/09/20 (US62/221,072)

(51) Cl.Int./Int.Cl. *A42B 3/04* (2006.01),
A42B 3/06 (2006.01)
(72) Inventeurs/Inventors:
DUROCHER, JACQUES, CA;
GENEREUX, MARIE-CLAUDE, CA
(73) Propriétaire/Owner:
BAUER HOCKEY LTD., CA
(74) Agent: SMART & BIGGAR LP

(54) Titre : CASQUE
(54) Title: HELMET



(57) **Abrégé/Abstract:**

A helmet for protecting a wearer's head. The helmet comprises an outer shell comprising a first shell member and a second shell member movable relative to one another in a longitudinal direction of the helmet to adjust a fit of the helmet on the wearer's head. The helmet comprises an adjustment mechanism configured to control movement of the first shell member and the second shell member relative to one another. The adjustment mechanism comprises an actuator movable between a first position in which the first shell member and the second shell member are allowed to move relative to one another and a second position in which the first shell member and the second shell member are precluded from moving relative to one another. The actuator is configured to lock the first shell member and the second shell member relative to one another without extending through a given one of the first shell member and the second shell member.

85493-709

ABSTRACT

A helmet for protecting a wearer's head. The helmet comprises an outer shell comprising a first shell member and a second shell member movable relative to one another in a longitudinal direction of the helmet to adjust a fit of the helmet on the wearer's head. The helmet comprises an adjustment mechanism configured to control movement of the first shell member and the second shell member relative to one another. The adjustment mechanism comprises an actuator movable between a first position in which the first shell member and the second shell member are allowed to move relative to one another and a second position in which the first shell member and the second shell member are precluded from moving relative to one another. The actuator is configured to lock the first shell member and the second shell member relative to one another without extending through a given one of the first shell member and the second shell member.

85493-709

HELMET

FIELD

- 5 The invention relates generally to helmets and, more particularly, to adjustable helmets providing impact protection (e.g., during sports or other activities).

BACKGROUND

- 10 Helmets are worn in sports (e.g., hockey, lacrosse, football, etc.) and other activities (e.g., motorcycling, industrial work, military activities, etc.) to protect their wearers against head injuries. Certain helmets can be adjustable so that a fit of the helmet on a wearer's head can be adjusted.
- 15 In particular, some helmets comprise a front shell member and a rear shell member and an adjustment system that allows relative movement between the front and rear shell members of the helmet in order to adjust the fit of the helmet on the wearer's head. While such adjustment systems provide a desired adjustment of the helmet, they may also present certain disadvantages. For
- 20 instance, the adjustment system may sometimes be bulky or otherwise affect an appearance (e.g., dimensions) of the helmet and/or may be prone to damage (e.g., deformation, breaking) which may prevent or otherwise affect proper functioning of the adjustment system.
- 25 For these and/or other reasons, there is a need to improve adjustable helmets.

SUMMARY

- 30 In accordance with one aspect of the invention, there is provided a helmet for protecting a wearer's head. The helmet comprises an outer shell comprising a first shell member and a second shell member movable relative to one another in

85493-709

a longitudinal direction of the helmet to adjust a fit of the helmet on the wearer's head. The helmet comprises an adjustment mechanism configured to control movement of the first shell member and the second shell member relative to one another. The adjustment mechanism comprises an actuator movable between a
5 first position in which the first shell member and the second shell member are allowed to move relative to one another and a second position in which the first shell member and the second shell member are precluded from moving relative to one another. The actuator is configured to lock the first shell member and the second shell member relative to one another without extending through a given
10 one of the first shell member and the second shell member.

In accordance with another aspect of the invention, there is provided a helmet for protecting a wearer's head. The helmet comprises an outer shell comprising a first shell member and a second shell member movable relative to one another to
15 adjust a size of a cavity for receiving the wearer's head. The helmet also comprises an adjustment mechanism comprising an actuator movable between a first position in which the size of the cavity can be adjusted and a second position in which the size of the cavity is prevented from being adjusted. The actuator comprises a projection and the first shell member comprises a plurality of
20 recesses formed on a surface of the first shell member. When the actuator is in the second position and the cavity is of a first size, the projection is received in a first one of the recesses. When the actuator is in the second position and the cavity is of a second size, the projection is received in a second one of the recesses.

25

In accordance with another aspect of the invention, there is provided a helmet for protecting a wearer's head. The helmet comprises an outer shell comprising a first shell member and a second shell member movable relative to one another in a longitudinal direction of the helmet to adjust a fit of the helmet on the wearer's
30 head. The helmet further comprises an adjustment mechanism configured to control movement of the first shell member and the second shell member relative

85493-709

to one another. The adjustment mechanism comprises an actuator movable between a first position in which the first shell member and the second shell member are allowed to move relative to one another and a second position in which the first shell member and the second shell member are precluded from moving relative to one another. The actuator is configured to lock the first shell member and the second shell member relative to one another by extending through the first shell member and without extending through the second shell member.

10 In accordance with another aspect of the invention, there is provided a helmet for protecting a wearer's head. The helmet comprises an outer shell comprising a first shell member and a second shell member movable relative to one another in a longitudinal direction of the helmet to adjust a fit of the helmet on the wearer's head. The helmet further comprises adjustment mechanism configured to control
15 movement of the first shell member and the second shell member relative to one another. The adjustment mechanism comprises an actuator movable between a first position in which the first shell member and the second shell member are allowed to move relative to one another and a second position in which the first shell member and the second shell member are precluded from moving relative
20 to one another. The actuator comprises a locking projection configured to lock the first shell member and the second shell member relative to one another, the actuator engages a point of attachment of the first shell member and the second shell member.

25 In accordance with another aspect of the invention, there is provided a helmet for protecting a wearer's head. The helmet comprises a first shell member and a second shell member movable relative to one another in a longitudinal direction of the helmet to adjust a fit of the helmet on the wearer's head. The helmet further comprises an adjustment mechanism. The adjustment mechanism
30 comprises a first component that sandwiches the second shell member to the first shell member and having at least one protrusion protruding from the first

shell member. The adjustment mechanism also comprises a second component connected to the first component at the at least one protrusion to inhibit desandwiching of the second shell member from the first shell member. The second component has at least one projection adjacent at least one of the at
5 least one protrusion and pivotally movable to a position where the at least one projection engages the second shell member to lock the first and second shell members against movement in the longitudinal direction.

In accordance with another aspect of the invention, there is provided a helmet for
10 protecting a wearer's head. The helmet comprises an outer shell comprising a first shell member and a second shell member movable relative to one another in a longitudinal direction of the helmet to adjust a fit of the helmet on the wearer's head. The helmet also comprises an adjustment mechanism configured to control movement of the first shell member and the second shell member relative
15 to one another. The adjustment mechanism comprises an actuator movable between a first position in which the first shell member and the second shell member are allowed to move relative to one another and a second position in which the first shell member and the second shell member are precluded from moving relative to one another. The actuator engages a point of attachment of
20 the first shell member and the second shell member. The actuator comprises a locking projection configured to lock the first shell member and the second shell member relative to one another by extending through the first shell member to engage the second shell member without extending through the second shell member. The locking projection comprises a top surface that contacts an outer
25 surface of the first shell member when the actuator is moved between the first and second positions such as to exert a threshold resistance on the outer surface of the first shell member.

In accordance with another aspect of the invention, there is provided a helmet for
30 protecting a wearer's head. The helmet comprises an outer shell. The outer shell comprises a first shell member and a second shell member movable relative to

one another in a longitudinal direction of the helmet to adjust a size of a cavity for receiving the wearer's head. The helmet also comprises an adjustment mechanism configured to control movement of the first shell member and the second shell member relative to one another. The adjustment mechanism

5 comprises an actuator movable between a first position in which the first shell member and the second shell member are allowed to move relative to one another and a second position in which the first shell member and the second shell member are precluded from moving relative to one another. The adjustment mechanism also comprises two points of attachment between the first shell

10 member and the second shell member, the two points of attachment configured to interconnect the first shell member and the second shell member while allowing the first shell member and the second shell member to move relative to one another when the actuator is in the first position. The adjustment mechanism further comprises a locking recess on an outer surface of the second shell

15 member. The actuator comprises a locking projection configured such that, when the cavity is of a first size and the actuator is in the second position, the locking projection extends through the first shell member at a point located between the two points of attachment interconnecting the first shell member and the second shell member and is received by the locking recess to lock the first

20 shell member and the second shell member relative to one another without extending through the second shell member, wherein the locking projection is a first locking projection. The actuator comprises a plurality of locking projections, inclusive of the first locking projection, that extend through the first shell member when the actuator is in the second position. Each locking projection of the

25 plurality of locking projections projects away from an inner face of the actuator and is disposed between the two points of attachment interconnecting the first shell member and the second shell member at a different location along the longitudinal direction of the helmet. Adjacent ones of the plurality of locking projections are joined at upper ends thereof by a surface that projects away from

30 the inner face of the actuator and extends between the adjacent locking projections in the longitudinal direction of the helmet.

In accordance with another aspect of the invention, there is provided a helmet for protecting a wearer's head. The helmet comprises an outer shell. The outer shell comprises a first shell member and a second shell member movable relative to one another in a longitudinal direction of the helmet to adjust a size of a cavity for receiving the wearer's head. The helmet also comprises an adjustment mechanism configured to control movement of the first shell member and the second shell member relative to one another. The adjustment mechanism comprises an actuator movable between a first position in which the first shell member and the second shell member are allowed to move relative to one another and a second position in which the first shell member and the second shell member are precluded from moving relative to one another. The adjustment mechanism also comprises two points of attachment between the first shell member and the second shell member, the two points of attachment configured to interconnect the first shell member and the second shell member while allowing the first shell member and the second shell member to move relative to one another when the actuator is in the first position. The adjustment mechanism further comprises a locking recess on an outer surface of the second shell member. The actuator comprises a locking projection configured such that, when the cavity is of a first size and the actuator is in the second position, the locking projection extends through the first shell member at a point located between the two points of attachment interconnecting the first shell member and the second shell member and is received by the locking recess to lock the first shell member and the second shell member relative to one another without extending through the second shell member, wherein the locking projection is a first locking projection. The actuator comprises a plurality of locking projections, inclusive of the first locking projection, that extend through the first shell member when the actuator is in the second position. The plurality of locking projections comprises a second locking projection configured such that, when the cavity is of a second size and the actuator is in the second position, the second locking projection extends through the first shell member at a point located between the

two points of attachment interconnecting the first shell member and the second shell member and is received by the locking recess to lock the first shell member and the second shell member relative to one another without extending through the second shell member. The first and second locking projections are joined at
5 upper ends thereof by a surface that projects away from the inner face of the actuator and extends between the first and second locking projections in the longitudinal direction of the helmet.

These and other aspects of the invention will now become apparent to those of
10 ordinary skill in the art upon review of the following description of embodiments of the invention in conjunction with the accompanying drawings.

BRIEF DESCRIPTION OF THE DRAWINGS

15 A detailed description of embodiments of the invention is provided below, by way of example only, with reference to the accompanying drawings, in which:

Figure 1 is a perspective view of an example of a helmet in accordance with a non-limiting embodiment;

20

Figures 2 and 3 are a front and a side elevation view of the helmet;

Figures 4 and 5 show a head of a wearer of the helmet;

25 Figure 6 shows internal dimensions of a head-receiving cavity of the helmet;

Figures 7 and 8 are a front and a side elevation view of a front shell member of the helmet;

30 Figures 9 and 10 are a front and a side elevation view of a rear shell member of the helmet;

85493-709

Figure 11 is an exploded view of an outer shell of the helmet and an adjustment mechanism of the helmet;

5 Figures 12 and 13 are a front and a side elevation view of a peg plate of an adjustment element of the adjustment mechanism;

Figure 14 is a perspective view of an actuator of the adjustment element for selectively allowing and precluding relative movement between the front and rear
10 shell members of the helmet;

Figures 15, 16 and 17 are a rear, a top and a front elevation view of the actuator;

Figure 18 is a perspective view of the actuator in accordance with another
15 embodiment;

Figure 19 is a front elevation view of a pivot member of the actuator;

Figures 20 and 21 respectively show a perspective view of the helmet with the
20 actuator of the adjustment element in a locked ("closed") position and an unlocked ("open") position; and

Figure 22 shows an exploded view of the helmet, including an inner padding of
25 the helmet.

It is to be expressly understood that the description and drawings are only for the purpose of illustrating certain embodiments of the invention and are an aid for understanding. They are not intended to be a definition of the limits of the
30 invention.

85493-709

DETAILED DESCRIPTION OF EMBODIMENTS

Figures 1 to 3 show an example of a helmet 10 for protecting a head 11 of a wearer in accordance with an embodiment of the invention. In this embodiment, the helmet 10 is a sports helmet and the wearer is a sports player. More particularly, in this embodiment, the helmet 10 is a hockey helmet for protecting the head 11 of the wearer who is a hockey player. In other embodiments, the helmet 10 may be any other type of helmet for other sports (e.g., lacrosse, football, baseball, cycling, skiing, snowboarding, horseback riding, etc.) and activities other than sports (e.g., motorcycling, industrial applications, military applications, etc.) in which protection against head injury is desired.

The helmet 10 defines a cavity 13 for receiving the wearer's head 11 to protect the wearer's head 11 when the helmet 10 is impacted (e.g., when the helmet 10 hits a board or an ice or other skating surface of a hockey rink or is struck by a puck or a hockey stick). In this embodiment, the helmet 10 may provide protection against various types of impacts, including high-energy impacts and low-energy impacts.

As further discussed below, in this embodiment, the helmet 10 is adjustable to adjust how it fits on the wearer's head 11 and its adjustability is implemented by taking up less space, which may enable it to provide better protection (e.g., include more padding in certain areas) and/or have a more pleasing appearance (e.g., be less bulky in certain areas).

In response to an impact, the helmet 10 absorbs energy from the impact to protect the wearer's head 11. The helmet 10 protects various regions of the wearer's head 11. As shown in Figures 4 and 5, the wearer's head 11 comprises a front region FR, a top region TR, left and right side regions LS, RS, a back region BR, and an occipital region OR. The front region FR includes a forehead and a front top part of the head 11 and generally corresponds to a frontal bone

85493-709

region of the head 11. The left and right side regions LS, RS are approximately located above the wearer's ears. The back region BR is opposite the front region FR and includes a rear upper part of the head 11. The occipital region OR substantially corresponds to a region around and under the head's occipital protuberance.

The helmet 10 comprises an external surface 18 and an internal surface 20 that contacts the wearer's head 11 when the helmet 10 is worn. The helmet 10 has a front-back axis FBA, a left-right axis LRA, and a vertical axis VA which are respectively generally parallel to a dorsoventral axis, a dextrosinistral axis, and a cephalocaudal axis of the wearer when the helmet 10 is worn and which respectively define a front-back direction, a lateral direction, and a vertical direction of the helmet 10. Since they are generally oriented longitudinally and transversally of the helmet 10, the front-back axis FBA and the left-right axis LRA can also be referred to as a longitudinal axis and a transversal axis, respectively, while the front-back direction and the lateral direction can also be referred to a longitudinal direction and a transversal direction, respectfully. As shown in Figures 2 and 3, a length L of the helmet 10 is a dimension of the helmet 10 in its longitudinal direction, a width W of the helmet 10 is a dimension of the helmet 10 in its transversal direction, and a height H of the helmet 10 is a dimension of the helmet 10 in its vertical direction.

In this embodiment, the helmet 10 comprises an outer shell 12 and inner padding 15. The inner padding 15 is disposed between the outer shell 12 and the wearer's head 11 in use to absorb impact energy when the helmet 10 is impacted. The helmet 10 may also comprise a chinstrap (not shown) for securing the helmet 10 to the wearer's head 11. A faceguard 14 may also be provided to protect at least part of the wearer's face (e.g., a grid (sometimes referred to as a "cage") or a visor (sometimes referred to as a "shield")).

30

85493-709

The outer shell 12 provides strength and rigidity to the hockey helmet 10. To that end, the outer shell 12 is made of rigid material. For example, in various embodiments, the outer shell 12 may be made of thermoplastic material such as polyethylene (PE), polyamide (nylon), or polycarbonate, of thermosetting resin, or of any other suitable material. The outer shell 12 has an inner surface 17 facing the inner padding 15 and an outer surface 19 opposite the inner surface 17. The outer surface 19 of the outer shell 12 constitutes at least part of the external surface 18 of the helmet 10.

10 In this embodiment, the outer shell 12 comprises a front shell member 22 and a rear shell member 24 that are connected to one another. As shown in Figures 7 and 8, the front shell member 22 comprises a top portion 21 for facing at least part of the top region TR of the wearer's head 11, a front portion 23 for facing at least part of the front region FR of the wearer's head 11, and left and right side portions 25L, 25R extending rearwardly from the front portion 23 for facing at least part of the left and right side regions LS, RS of the wearer's head 11, respectively. The rear shell member 24 comprises a top portion 29 for facing at least part of the top region TR of the wearer's head 11, a back portion 31 for facing at least part of the back region BR of the wearer's head 11, an occipital portion 37 for facing at least part of the occipital region OR of the wearer's head 11, and left and right side portion 35L, 35R extending forwardly from the back portion 31 for facing at least part of the left and right side regions LS, RS of the wearer's head 11, respectively.

25 In this embodiment, the helmet 10 is adjustable to adjust how it fits on the wearer's head 11. To that end, the helmet 10 comprises an adjustment mechanism 40 for adjusting a fit of the helmet 10 on the wearer's head 11. The adjustment mechanism 40 may allow the fit of the helmet 10 to be adjusted by adjusting one or more internal dimensions of the cavity 13 of the helmet 10, such as a front-back internal dimension FBD of the cavity 13 in the front-back direction

30

85493-709

of the helmet 10 and/or a left-right internal dimension LRD of the cavity 13 in the left-right direction of the helmet 10, as shown in Figure 6.

5 More particularly, in this embodiment, the adjustment mechanism 40 allows the front shell member 22 and the rear shell member 24 to move relative to one another to adjust the fit of the helmet 10 on the wearer's head 11. The front shell member 22 and the rear shell member 24 may comprise smooth, interference-free sliding surfaces that are adapted to face or be in contact with each other when the fit of the helmet 10 is adjusted to a selected size. In this example, 10 relative movement of the shell members 22, 24 for adjustment purposes is in the front-back direction of the helmet 10 such that the front-back internal dimension FBD of the cavity 13 of the helmet 10 is adjusted. This dimension may be adjusted between a minimum size of the helmet 10, a maximum size of the helmet 10 and zero or more intermediate sizes of the helmet 10.

15

In this embodiment, the adjustment mechanism 40 comprises a left adjustment element 41_L disposed on a left side 51_L of the helmet 10 and a right adjustment element 41_R disposed on a right side 51_R of the helmet 10. In this example, the left and right adjustment elements 41_L, 41_R are each disposed in a position in the 20 vertical direction of the helmet 10 slightly above the wearer's ear. It should be understood that, in this embodiment, the left side 51_L of the helmet 10 is homologous to the right side 51_R of the helmet 10 and, therefore, the below description of components with respect to one side of the helmet 10 also applies to the other side of the helmet 10. However, this need not be the case in all 25 embodiments. For example, the adjustment mechanism 40 may comprise more than two adjustment elements like the adjustment elements 41_L, 41_R or there may only be a single adjustment element like the adjustment elements 41_L, 41_R in the helmet 10.

30 Each of the adjustment elements 41_L, 41_R of the adjustment mechanism 40 comprises an actuator 60 movable between (i) a first position, referred to an

85493-709

“open position”, in which the front shell member 22 and the rear shell member 24 are allowed to move relative to one another to adjust the fit of the helmet 10 and (ii) a second position, referred to as a “closed position”, in which the front shell member 22 and the rear shell member 24 are precluded from moving relative to one another so as to maintain the fit of the helmet 10 as adjusted.

In this embodiment, the actuator 60, which will be described in further detail later on, comprises a plurality of locking projections 84₁-84_P configured to lock the front shell member 22 and the rear shell member 24 relative to one another in the closed position of the actuator 60. The actuator 60 is relatively small such that it occupies less space in the helmet 10. Notably, in this embodiment, the locking projections 84₁-84_P are dimensioned such that they can lock the front shell member 22 and the rear shell member 24 relative to one another in the closed position without extending through a given one of the front shell member 22 and the rear shell member 24. In this case, the locking projections 84₁-84_P can lock the front shell member 22 and the rear shell member 24 relative to one another in the closed position while penetrating into the rear shell member 24 yet without extending through it.

In addition to the actuator 60, each of the adjustment elements 41_L, 41_R of the adjustment mechanism 40 also comprises a plurality of openings 104₁-104_H on the front shell member 22 and a plurality of recesses (also referred to as “locking recesses”) 100₁-100_R on the rear shell member 24. These are respectively aligned with the locking projections 84₁-84_P of the actuator 60 such that the locking projections 84₁-84_P of the actuator 60 may extend through respective ones of the openings 104₁-104_H of the front shell member 22 and be received in corresponding ones of the recesses 100₁-100_R of the rear shell member 24 to lock the front shell member 22 and the rear shell member 24 relative to one another. As they are received in the corresponding ones of the recesses 100₁-100_R of the rear shell member 24, the locking projections 84₁-84_P of the actuator 60 do not extend through the rear shell member 24. Conversely, the locking

85493-709

projections 84₁-84_P of the actuator 60 may be moved out of the recesses 100₁-100_R of the rear shell member 24 to allow relative movement of the front shell member 22 and the rear shell member 24 while the actuator 60 remains in the open position.

5

Each of the adjustment elements 41_L, 41_R of the adjustment mechanism 40 is substantially aligned with a recessed region 61 of the front shell member 22 on a respective one of the left and right side portions 25_L, 25_R of the front shell member 22. For instance, the actuator 60 of each of the adjustment elements
10 41_L, 41_R is received in the recessed region 61 of the front shell member 22.

In this embodiment, as shown in Figures 11 and 21, each of the adjustment elements 41_L, 41_R of the adjustment mechanism 40 comprises a "point of attachment" of the front shell member 22 and the rear shell member 24. The
15 point of attachment of the front and rear shell members 22, 24 is a point at which the front and rear shell members 22, 24 are interconnected. In particular, in this embodiment, the point of attachment of the first and second shell members 22, 24 is implemented by a peg plate 68 of each of the adjustment elements 41_L, 41_R. The actuator 60 comprises a pivot member 90 that engages the peg plate
20 68 to the actuator 60 such that the peg plate 68 supports the actuator 60. Thus, the peg plate 68, together with the pivot member 90, interconnects the front shell member 22 and the rear shell member 24 while the actuator 60 is in the open position and the helmet 10 is being adjusted. In other words, the peg plate 68 and the pivot member 90 preclude the front and rear shell members 22, 24 from
25 entirely disengaging one another.

Since, in this embodiment, it is mounted to the pivot member 90 and thus pivotable relative to the front shell member 22 and the rear shell member 24, the actuator 60 constitutes a lever.

30

85493-709

As shown in Figures 12 and 13, in this embodiment, the peg plate 68 comprises a base portion 69 and a pair of pegs 70 protruding from the base portion 69, the pegs 70 being configured to be received in the front and rear shell members 22, 24. In use, the peg plate 68 is positioned such that its base portion 69 is disposed between the rear shell member 24 and the inner padding 15 with the pegs 70 extending outwardly (i.e., away from the wearer's head), in the lateral direction of the helmet 10, and traversing the front and rear shell members 22, 24 such that the pegs 70 protrude outwards from the front shell member 22. Thus, the peg plate 68 may be considered to "sandwich" the front and rear shell members 22, 24, while the actuator 60 inhibits "desandwiching" or separation of the front and rear shell members 22, 24.

In this embodiment, as shown in Figure 19, the pivot member 90 is a spring wire. The pivot member 90 comprises a first end portion 91 and a second end portion 94 which are configured to be received in the pegs 70 of the peg plate 68. In use, the first and second end portions 91, 94 extend along a direction generally parallel to the longitudinal direction of the helmet 10 such as to define a pivot axis 93 that is generally parallel to the longitudinal direction of the helmet 10. The pivot member 90 also comprises a central portion 96 spaced away from the first and second end portions 91, 94. More specifically, the central portion 96 lies away from the pivot axis 93 defined by the first and second end portions 91, 94.

In this embodiment, the pivot member 90 comprises a metallic material (e.g., steel). The pivot member 90 may comprise any other suitable material in other embodiments.

In order to receive the pegs 70 of the peg plate 68, the rear shell member 24 comprises a pair of parallel channels 62 at a position slightly above the wearer's ear in the vertical direction of the helmet 10. The channels 62 are elongate and extend predominantly in the longitudinal direction of the helmet 10. For its part, in order to receive the pegs 70 of the peg plate 68, the front shell member 22

85493-709

comprises a pair of openings 64 which are aligned with the channels 62 when the front shell member 22 and the rear shell member 24 are interconnected.

Each of the pegs 70, which protrude from the recessed region 61 of the front shell member 22, is configured to receive the pivot member 90 of the actuator 60. For instance, in this example, the pivot member 90 is received in an opening 71 of a respective one of the pegs 70. This holds the front shell member 22 and the rear shell member 24 together, and as such, each of the pegs 70 of the peg plate 68 is considered to be a point of attachment of the front and rear shell members 22, 24. Through its pivot member 90, the actuator 60 thus engages at least one point of attachment of the front and rear shell members 22, 24, and in this particular example, engages two points of attachments of the front and rear shell members 22, 24 (i.e., the two pegs 70). If the actuator 60 is in the open position, the pegs 70 can slide back and forth within the channels 62, which allows the front-back internal dimension FBD of the cavity 13 of the helmet 10 to be varied, i.e., the fit of the helmet 10 can be adjusted.

In this embodiment, the actuator 60 comprises an actuator plate 80. The actuator plate 80 comprises an inner face 81 and an outer face 83, either or both of which may be curved in order to follow a general curvature of the outer shell 12. The actuator plate 80 comprises a lower edge 89 and an upper edge 92 opposite the lower edge 89. The lower and upper edges 89, 92 correspond to the lower and upper edges of the actuator 60. In the closed position of the actuator 60, the lower edge 89 is positioned lower in the vertical direction of the helmet 10 than the upper edge 92.

The actuator plate 80 may be made of the same rigid material as the front shell member 22 and/or the rear shell member 24. Alternatively, the actuator 60 may be made of a different material.

30

85493-709

The actuator 60 also comprises a cam portion 85 for selectively placing the actuator 60 in its open and closed positions. In this example, the cam portion 85 of the actuator 60 comprises a cam post 82 which comprises one or more clevis members 72 on the inner face 81 of the actuator plate 80. The clevis members 72 are configured to receive the pegs 70 which protrude from the recessed region 61 of the front shell member 22 via the openings 64.

The pivot member 90 interacts with the pegs 70 of the peg plate 68 to provide a hinge connection which allows the actuator 60 to pivot about the pivot axis 93 such that the actuator 60 rotates in relation to the front and rear shell members 22, 24 of the helmet 10. To that end, the locking projections 84₁-84_P may comprise openings 87 configured to receive the pivot member 90 therein. In particular, the openings 87 receive the first and second end portions 91, 94 of the pivot member 90. In such examples, the openings 98 of the certain ones of the locking projections 84₁-84_P are aligned with one another. Other devices and shapes could be used in lieu of the pivot member 90 to implement such a hinge connection.

The cam post 82 comprises at least two surfaces, one of which contacts an outer surface 27 of the front shell member 22 when the actuator 60 is in the open position and the other of which contacts the outer surface 27 of the front shell member 22 when the actuator 60 is in the closed position. Specifically, when the actuator 60 is in the closed position, a "closed position cam surface" 86 of the cam post 82 rests against the outer surface 27 of the front shell member 22, and when the actuator 60 is in the open position, an "open position cam surface" 88 of the cam post 82 is in contact with the outer surface 27 of the front shell member 22.

The actuator 60 also comprises the aforementioned locking projections 84₁-84_P. The locking projections 84₁-84_P project away from the inner face 81 of the actuator plate 80 (which may be curved). For example, the locking projections

85493-709

84₁-84_P may project perpendicularly to a plane tangent to at least one point on the curved outer face 83 of the actuator plate 80. In this embodiment, as shown in Figures 14 to 17, the actuator 60 comprises four locking projections 84₁-84_P. However, in other embodiments, the actuator 60 may comprise more or less
5 locking projections 84₁-84_P. For example, as shown in Figure 18, in some embodiments, the actuator 60 may comprise five or more locking projections 84₁-84_P.

Furthermore, in this embodiment, at least one locking projection 84_i may be
10 positioned such as to prevent or otherwise minimize bending of the locking projection 84_i. More specifically, in this example of implementation, the locking projection 84_i is positioned such as to be adjacent to a given one of the pegs 70 of the peg plate 68 when the actuator 60 is in its closed position. Because each of the pegs 70 constitutes a point of attachment point between the front and rear
15 shell members 22, 24, as discussed above, the outer shell 12 may be subjected to reduced bending at the pegs 70 compared to other points of the outer shell 12 along the longitudinal direction of the helmet 10. Thus, positioning a locking projection 84_i of the actuator 60 such as to be adjacent to one of the pegs 70 exposes the locking projection 84_i to reduced bending compared to other
20 possible positions of the locking projection 84_i. This may hence allow the use of shorter locking projections such that they may penetrate only part way into the rear shell member while still achieving satisfactory locking performance.

In this embodiment, the locking projections 84₁-84_P remain fixed in relation to the
25 points of attachment of the front and rear shell members 22, 24 when the fit of the helmet 10 is adjusted to different sizes. More specifically, when the actuator 60 is in its closed position, a distance between a given locking projection 84_i and a given one of the pegs 70 remains constant whether the helmet 10 is adjusted to a first size or a second size different from the first size.

30

85493-709

The locking projections 84₁-84_P may be distributed at different points along the inner face 81 of the actuator plate 80. In this embodiment, the distribution occurs along an axis that is predominantly parallel to the pivot axis 93 and may be offset therefrom, although the general direction along which the locking projections 84₁-84_P are oriented may be different from the pivot axis 93. Moreover, in some embodiments, the locking projections 84₁-84_P may be evenly spaced from one another.

The locking projections 84₁-84_P need not be evenly distributed along the actuator plate 80, however a distance between adjacent locking projections 84₁-84_P is designed in relation to a distance between adjacent locking recesses 100₁-100_R on the rear shell member 24. For example, assuming that the distance between pairs of adjacent locking recesses 100₁-100_R on the rear shell member 24 is the same and is equal to "X" (which need not be the case in all embodiments), the distance between adjacent locking projections 84₁-84_P along the actuator plate 80 should be X, or a multiple thereof (i.e., an integer multiple), to allow proper alignment of the locking projections 84₁-84_P and a corresponding subset of the locking recesses 100₁-100_R in which those locking projections will be lodged. As such, there may be a greater number of locking recesses 100₁-100_R than of locking projections 84₁-84_P. Having a greater number of locking recesses 100₁-100_R may allow the locking projections 84₁-84_P to be held within the locking recesses 100₁-100_R at a greater number of positions, each such position defining a different length of the front-back internal dimension FBD of the cavity 13 of the helmet 10. Thus, the fit of the helmet 10 may be adjusted with a more refined granularity.

For instance, in some cases, the distance between adjacent locking recesses 100₁-100_R may be at least 1 mm, in some cases at least 2 mm, in some cases at least 3 mm, in some cases at least 5 mm, in some cases at least 10 mm, in some cases at least 15 mm, in some cases at least 20 mm, in some cases at least 25 mm, and in some cases even more.

85493-709

Each of the locking projections 84_1-84_P has a length L_P , a height H_P and a width W_P . With reference to Figure 16, the length L_P of a given locking projection 84_i is a distance by which that locking projection 84_i protrudes into the front and rear shell members 22, 24 (i.e., the outer shell 12) of the helmet 10 when the actuator 60 is in the closed position. In other words, the length L_P of the locking projection 84_i is the distance by which the locking projection 84_i extends past the closed position cam surface 86 when the actuator 60 is in the closed position. It is noted that the length L_P of different ones of the locking projections 84_1-84_P may be slightly different because of the curvature of the front and rear shell members 22, 24 of the helmet 10.

In this embodiment, the length L_P of a locking projection 84_i may be relatively small. For instance, in some cases, the length L_P of the locking projection 84_i may be no more than 20 mm, in some cases, no more than 15 mm, in some cases no more than 10 mm, in some cases no more than 5 mm, in some cases no more than 3 mm and in some cases even less (e.g., 1.5 mm). This particularly small length of the locking projections 84_1-84_P may result in less deformation of the locking projections 84_1-84_P than if their length was greater. Consequently, this may result in a stronger adjustment mechanism 40 that is less prone to deformation.

Furthermore, in some cases, a ratio of the length L_P of the locking projections 84_1-84_P over the width W of the helmet 10 may be no more than 1:15, in some cases no more than 1:20, in some cases no more than 1:30, in some cases no more than 1:50, in some cases no more than 1:70, in some cases no more than 1:100, in some cases no more than 1:150, in some cases no more than 1:170, and in some cases even less.

Furthermore, in some cases, assuming that the front shell member 22 has a maximum thickness A in the immediate vicinity of the openings 104_1-104_H and

85493-709

the rear shell member 24 has a maximum thickness B in the immediate vicinity of the locking recesses 100₁-100_R, such that the front and rear shell members 22, 24 have a combined maximum thickness AB in the immediate vicinity of the openings 104₁-104_H and locking recesses 100₁-100_R, a difference between the
5 length L_P of the locking projections 84₁-84_P and the combined maximum thickness AB of the front and rear shell members 22, 24 may be no more than 5 mm, in some cases no more than 3 mm, in some cases no more than 2 mm, in some cases no more than 1 mm and in some cases even less (e.g., 0.5 mm).

10 With continued reference to Figure 16, the width W_P of a locking projection 84_i is a distance spanned by that locking projection 84_i along the pivot axis 93. In this embodiment, the width W_P of the locking projection 84_i may be relatively small. For instance, in some cases, the width W_P of the locking projection 84_i may be no more than 15 mm, in some cases no more than 10 mm, in some cases no more
15 than 5 mm, in some cases no more than 3 mm, and in some cases even less (e.g., 1.5 mm).

In some embodiments, the width W_P of the locking projection 84_i may be significant relative to the length L_P of the locking projection 84_i. For instance, in
20 some cases, a ratio W_P/L_P of the width W_P of the locking projection 84_i over the length L_P of the locking projection 84_i may be at least 0.5, in some cases at least 1, in some cases at least 1.5, in some cases at least 2, in some cases at least 3, and in some cases even more.

25 With reference to Figure 15, the height H_P of a given locking projection 84_i is a distance spanned by that locking projection 84_i in a direction from the upper edge 92 to the lower edge 89 of the actuator 60. In some cases, the height H_P of the locking projection 84_i may be no more than 20 mm, in some cases no more than 15 mm, in some cases no more than 10 mm, and in some cases no more than 5
30 mm, and in some cases even less (e.g., 3 mm).

85493-709

In some embodiments, the height H_P of the locking projection 84_i may be significant relative to the length L_P of the locking projection 84_i . For instance, in some cases, a ratio H_P/L_P of the height H_P of the locking projection 84_i over the length L_P of the locking projection 84_i may be at least 2, in some cases at least 4, 5 in some cases at least 6, in some cases at least 8, in some cases at least 10, and in some cases even more.

In this embodiment, the locking projections 84_1-84_P have a rectangular cross-section. As such, the locking projections 84_1-84_P may project like teeth from the 10 actuator 60. Providing the locking projections 84_1-84_P with a tooth-like shape may enhance a tactile feedback a wearer may receive to indicate that the helmet 10 has acquired its maximum size, its minimum size or an intermediate size. Stated differently, providing the locking projections 84_1-84_P with a tooth-like shape may assist in signaling to the wearer that the locking projections 84_1-84_P have been 15 received within corresponding ones of the locking recesses 100_1-100_R . However, it should be understood that the locking projections 84_1-84_P may have any other suitable cross-sectional shape. For example, in some embodiments, the locking projections 84_1-84_P may have a circular cross-sectional shape or an oval cross-sectional shape.

20

As shown in Figures 10 and 11, in this embodiment, the locking recesses 100_1-100_R are located on the rear shell member 24 at a position slightly above the wearer's ear in the vertical direction. (An opposite configuration is also envisaged whereby the locking recesses 100_1-100_R may be on the front shell member 22 25 while the openings 104_1-104_H aligned with the locking projections 84_1-84_P may be on the rear shell member 24.) Each of the locking recesses 100_1-100_R may have an internal profile configured to receive a respective one of the locking projections 84_1-84_P . Moreover, the rear shell member 24 (or the front shell member 22) may comprise a number of locking recesses 100_1-100_R at least 30 equal to the number of locking projections 84_1-84_P . A greater number of locking recesses 100_1-100_R allows for a greater variety of relative positions of the front

85493-709

and rear shell members 22, 24. The distance (in the front-back direction of the helmet 10) between adjacent pairs of locking recesses 100_1-100_R may be constant (i.e., does not vary). In other instances, various groupings of the locking recesses 100_1-100_R may form sets for which the distance between adjacent locking recesses 100_1-100_R of the set may be the same as the distance between the corresponding locking projections 84_1-84_P , whereby each such set represents a different helmet size.

In this embodiment, the locking recesses 100_1-110_R are “pocketed” in an outer surface 28 of the rear shell member 24 such that each locking recess 100_i constitutes a depression in the outer surface 28 of the rear shell member 24 but does not traverse an entirety of a thickness of the rear shell member 24. An extent of a given locking recess 100_i in the lateral direction of the helmet 10 may be referred to as a “depth” of the locking recess 100_i . The depth of each locking recess 100_i is sufficient to receive a respective locking projection 84_i when the actuator 60 is in the closed position and is less than the maximum thickness of the rear shell member 24 in a vicinity of the locking recesses 100_1-100_R . For instance, in some cases, the depth of the locking recesses 100_1-100_R may be no greater than 10 mm, in some cases no greater than 5 mm, in some cases no greater than 2 mm and in some cases even less (e.g., 0.5 mm)

Furthermore, in some cases, a difference between the maximum thickness B of the rear shell member 24 in the immediate vicinity of the locking recesses 100_1-100_R and the depth of the locking recesses 100_1-100_R may be no more than 5 mm, in some cases no more than 3 mm, in some cases no more than 1 mm and in some cases even less (e.g., 0.5 mm)

Furthermore, in some cases, a ratio of the depth of the locking recesses 100_1-100_R over the maximum thickness B of the rear shell member 24 in the vicinity of the locking recesses 100_1-100_R may be no more than 0.75, in some cases no

85493-709

more than 0.5, in some cases no more than 0.25, and in some cases even less (e.g., 0.1).

5 In other embodiments, the locking recesses 100₁-100_R may constitute openings that traverse the thickness of the rear shell member 24, even though the locking projections 84₁-84_P themselves do not project far enough within the locking recesses 100₁-100_R to reach the inner surface 17 of the outer shell 12. In such
10 recesses 100₁-100_R is 1.

In use, the actuator 60 may be raised out of, or lowered into, the recessed region 61 of the front shell member 22. When the actuator 60 sits within the recessed region 61 of the front shell member 22 (i.e., when the actuator 60 is in the closed
15 position), the actuator plate 80 rests predominantly vertically, with the cam post 82 and the locking projections 84₁-84_P extending in the lateral direction towards an inside of the cavity 13 of the helmet 10. When the actuator 60 is in this closed position, the outer face 83 of the actuator plate 80 may follow the general smooth curvature of an exterior of the outer shell 12 and the locking projections 84₁-84_P
20 may be hidden from view.

The adjustment mechanism 40 allows the actuator 60 to be swung from the closed position to the open position when a rotational force is applied to the actuator 60. Such a rotational force may be created by applying a force on the
25 actuator plate 80 (e.g.: on the inner face 81) in the lateral direction away from the helmet 10. In this embodiment, in order to facilitate access to the inner face 81 of the actuator plate 80 when the actuator 60 is in the closed position, the outer shell 12 may comprise an indentation 95 located on a periphery of the recessed region 61 adjacent the bottom edge 89 of the actuator 60. Moreover, the actuator
30 60 itself may be configured to facilitate access to the inner face 81 of the actuator plate 80 when the actuator 60 is in the closed position. More specifically, in this

85493-709

example of implementation, a periphery 65 of the actuator plate 80 comprises a recessed portion 67 adjacent its bottom edge 89 where the actuator plate 80 is relatively thin such that the wearer of the helmet can more easily insert his/her finger between the actuator 60 and the front shell member 22.

5

With the actuator 60 of the adjustment mechanism 40 having been raised out of the recessed region 61 of the front shell member 22 by a user, the actuator 60 acquires the open position, and the actuator plate 80 is disposed predominantly horizontally with the cam post 82 and locking projections 84₁-84_P extending vertically downwards. It is noted that when the actuator 60 is in the open position, the locking projections 84₁-84_P may be visible from an exterior of the helmet 10.

When the actuator 60 is placed in the open position, the locking projections 84₁-84_P have been removed from engagement with the locking recesses 100₁-100_R and the front shell member 22 and the rear shell member 24 are free to slide relative to one another along the direction of the channels 62 of the rear shell member 24. The wearer may therefore slide the front shell member 22 and the rear shell member 24 relative to one another so as to adjust the size of the helmet 10.

20

Once a desired size of the helmet 10 has been selected, the actuator 60 may be swung from the open position back into the closed position, thereby causing the locking projections 84₁-84_P (which project away from the inner face 81 of the actuator plate 80) to pass through the openings 104₁-104_H of the front shell member 22 and be received in the locking recesses 100₁-100_R of the rear shell member 24 without extending through the rear shell member 24. Some slight fine tuning of the size of the helmet 10 while closing the actuator 60 may be performed until tactile feedback has been received that the locking projections 84₁-84_P have indeed engaged with corresponding ones of the locking recesses 100₁-100_R. With the locking projections 84₁-84_P passing through the openings

30

85493-709

104₁-104_H and resting in the locking recesses 100₁-100_R, motion of the rear shell member 24 relative to the front shell member 22 is precluded.

5 The cam surfaces 86, 88 may exert a threshold resistance on the outer surface 27 of the front shell member 22 against which a minimum rotational force must be applied to swing the actuator 60 between the closed and open positions, and vice versa. The cam surfaces 86, 88 may therefore prevent accidental rotation of the actuator 60 from one position to the other position without the necessary rotational force being applied to the actuator 60. Thus, for example, the cam
10 surfaces 86, 88 may cause the actuator 60 to be maintained in the open position until a downward force is applied on the outside face 83 of the actuator plate 80 in order to place the actuator 60 in the closed position.

Furthermore, in this embodiment, the locking projections 84₁-84_P may be
15 considered to be part of the cam portion 85. In particular, in this embodiment, similarly to the cam surfaces 86, 88, the locking projections 84₁-84_P are configured to exert a threshold resistance on the outer surface 27 of the front shell member 22 against which a minimum rotational force must be applied to swing the actuator 60 between the closed and open positions, and vice versa.
20 For instance, in this example of implementation, a top surface 55 of a locking projection 84_i may contact the outer surface 27 of the front shell member 22 when the actuator 60 is transitioning from its closed position to its open position and vice-versa such as to exert the threshold resistance on outer surface 27 of the front shell member 22.

25

In this embodiment, as shown in Figure 7, the outer shell 12 also comprises a plurality of ventilation holes 39₁-39_V allowing air to circulate around the wearer's head 11 for added comfort. In this case, each of the front and rear shell members 22, 24 defines respective ones of the ventilation holes 39₁-39_V of the outer shell
30 12. Ventilation holes 39₁-39_V may provide the added comfort of allowing air to circulate around the wearer's head, thus permitting perspiration to evaporate.

85493-709

With reference to Figure 20, in this embodiment, the inner padding 15 is disposed between the outer shell 12 and the wearer's head 11 in use to absorb impact energy when the helmet 10 is impacted. More particularly, the inner padding 15 comprises a shock-absorbing structure 32 that includes an outer surface 38 facing towards the outer shell 12 and an inner surface 34 facing towards the wearer's head 11. In this embodiment, the shock-absorbing structure 32 comprises a plurality of pads 36₁-36_N to absorb impact energy. The pads 36₁-36_N are responsible for absorbing at least a bulk of the impact energy transmitted to the inner padding 15 when the helmet 10 is impacted and can therefore be referred to as "absorption" pads.

For example, in this embodiment, each of the pads 36₁-36_N comprises a shock-absorbing material 50. For instance, in some cases, the shock-absorbing material 50 may include a polymeric cellular material, such as a polymeric foam (e.g., expanded polypropylene (EPP) foam, expanded polyethylene (EPE) foam, vinyl nitrile (VN) foam, polyurethane foam (e.g., PORON XRD foam commercialized by Rogers Corporation), or any other suitable polymeric foam material), or expanded polymeric microspheres (e.g., ExpanceTM microspheres commercialized by Akzo Nobel). In some cases, the shock-absorbing material 50 may include an elastomeric material (e.g., a rubber such as styrene-butadiene rubber or any other suitable rubber; a polyurethane elastomer such as thermoplastic polyurethane (TPU); any other thermoplastic elastomer; etc.). In some cases, the shock-absorbing material 50 may include a fluid (e.g., a liquid or a gas), which may be contained within a container (e.g., a flexible bag, pouch or other envelope) or implemented as a gel (e.g., a polyurethane gel). Any other material with suitable impact energy absorption may be used in other embodiments. In other embodiments, a given one of the pads 36₁-36_N may comprise an arrangement (e.g., an array) of shock absorbers that are configured to deform when the helmet 10 is impacted. For instance, in some cases, the arrangement of shock absorbers may include an array of compressible cells that

can compress when the helmet 10 is impacted. Examples of this are described in U.S. Patent 7,677,538 and U.S. Patent Application Publication 2010/0258988.

5 In some embodiments, the shock-absorbing material 50 of different ones of the pads 36₁-36_N may be different. For instance, in some embodiments, the shock-absorbing material 50 of two, three, four or more the pads 36₁-36_N may be different. For example, in some embodiments, the shock-absorbing material 50 of a pad 36_i may be different from the shock-absorbing material 50 of another pad 36_j. For instance, in some cases, the shock-absorbing material 50 of the pad
10 36_i may be denser than the shock-absorbing material 50 of the pad 36_j. Alternatively or additionally, in some cases, the shock-absorbing material 50 of the pad 36_i may be stiffer than the shock-absorbing material 50 of the pad 36_j. Combinations of different densities, thickness and type of material for the pads 36₁-36_N may permit for better absorption of high- and low-energy impacts.

15

The absorption pads 36₁-36_N may be present in any suitable number. For example, in some embodiments, the plurality of absorption pads 36₁-36_N may include at least three pads, in some cases at least five pads, in some cases at least eight pads, and in some cases even more pads (e.g., at least ten pads or
20 more).

In addition to the absorption pads 36₁-36_N, in this embodiment, the inner padding
15 comprises comfort pads 52₁-52_K which are configured to provide comfort to the wearer's head. In this embodiment, when the helmet 10 is worn, the comfort pads 52₁-52_K are disposed between the absorption pads 36₁-36_N and the
25 wearer's head 11 to contact the wearer's head 11. The comfort pads 52₁-52_K may comprise any suitable soft material providing comfort to the wearer. For example, in some embodiments, the comfort pads 52₁-52_K may comprise polymeric foam such as polyvinyl chloride (PVC) foam, polyurethane foam (e.g.,
30 PORON XRD foam commercialized by Rogers Corporation), vinyl nitrile foam or

85493-709

any other suitable polymeric foam material. In some embodiments, given ones of the comfort pads 52₁-52_K may be secured (e.g., adhered, fastened, etc.) to respective ones of the absorption pads 36₁-36_N. In other embodiments, given ones of the comfort pads 52₁-52_K may be mounted such that they are movable
5 relative to the absorption pads 36₁-36_N. For example, in some embodiments, given ones of the comfort pads 52₁-52_K may be part of a floating liner as described in U.S. Patent Application Publication 2013/0025032, which, for instance, may be implemented as the SUSPEND-TECH™ liner found in the BAUER™ RE-AKT™ and RE-AKT 100™ helmets made available by Bauer
10 Hockey, Inc.. The comfort pads 52₁-52_K may assist in absorption of energy from impacts, in particular, low-energy impacts.

The helmet 10 may further comprise protective padding 33 disposed between the outer shell 12 and the wearer's head 11 at a position slightly above the wearer's
15 ear in the vertical direction corresponding to a position of a respective one of the left and right adjustment elements 41_L, 41_R of the adjustment mechanism 40. The protective padding 33 may comprise the shock-absorbing structure 32 and/or the comfort pads 52. Due to the relatively short length L_P of the locking projections 84₁-84_P by virtue of which the locking projections 84₁-84_P do not pass through the
20 rear shell member 24, more free space may be provided between the wearer's head and the outer shell 12 than in scenarios in which locking projections of a similar adjustment system were to extend through both the front and rear shell members 22, 24. This "free space" may allow the protective padding 33 to occupy more space in the lateral direction of the helmet 10. This may in turn
25 improve the protection provided by the protective padding 33 thus rendering the helmet 10 safer. For instance, in some cases, a thickness of the protective padding 33 may be at least 5 mm, in some cases at least 15 mm, in some cases at least 20 mm, in some cases at least 30 mm, in some cases at least 40 mm, in some cases at least 50 mm, and in some cases even more. Moreover, in some
30 cases, a ratio of the thickness of the protective padding 33 over the width W of the helmet 10 may be at least 0.01, in some cases at least 0.05, in some cases

85493-709

at least 0.1, in some cases at least 0.15, in some cases at least 0.2 and in some cases even more

Any feature of any embodiment discussed herein may be combined with any
5 feature of any other embodiment discussed herein in some examples of implementation.

Although in embodiments considered above the helmet 10 is a hockey helmet for protecting the head of a hockey player, in other embodiments, a helmet
10 constructed using principles described herein in respect of the helmet 10 may be another type of sport helmet. For instance, a helmet constructed using principles described herein in respect of the helmet 10 may be for protecting the head of a player of another type of contact sport (sometimes referred to as “full-contact sport” or “collision sport”) in which there are significant impact forces on the
15 player due to player-to-player and/or player-to-object contact. For example, in one embodiment, a helmet constructed using principles described herein in respect of the helmet 10 may be a lacrosse helmet for protecting the head of a lacrosse player. As another example, in one embodiment, a helmet constructed using principles described herein in respect of the helmet 10 may be a football
20 helmet for protecting the head of a football player. As another example, in one embodiment, a helmet constructed using principles described herein in respect of the helmet 10 may be a baseball helmet for protecting the head of a baseball player (e.g., a batter or catcher). Furthermore, a helmet constructed using principles described herein in respect of the helmet 10 may be for protecting the
25 head of a wearer involved in a sport other than a contact sport (e.g., bicycling, skiing, snowboarding, horseback riding or another equestrian activity, etc.).

Also, while in the embodiments considered above the helmet 10 is a sport helmet, a helmet constructed using principles described herein in respect of the
30 helmet 10 may be used in an activity other than sport in which protection against head injury is desired. For example, in one embodiment, a helmet constructed

using principles described herein in respect of the helmet 10 may be a motorcycle helmet for protecting the head of a wearer riding a motorcycle. As another example, in one embodiment, a helmet constructed using principles described herein in respect of the helmet 10 may be an industrial or military
5 helmet for protecting the head of a wearer in an industrial or military application.

In case of any discrepancy, inconsistency, or other difference between terms used herein and terms used in any document cited, meanings of the terms used herein are to prevail and be used.

10

Although various embodiments and examples have been presented, this was for the purpose of describing, but not limiting, the invention. Various modifications and enhancements will become apparent to those of ordinary skill in the art and are within the scope of the invention, which is defined by the appended claims.

15

CLAIMS

1. A helmet for protecting a wearer's head, the helmet comprising:
 - a) an outer shell comprising a first shell member and a second shell member movable relative to one another in a longitudinal direction of the helmet to adjust a fit of the helmet on the wearer's head;
 - b) an adjustment mechanism configured to control movement of the first shell member and the second shell member relative to one another, the adjustment mechanism comprising an actuator movable between a first position in which the first shell member and the second shell member are allowed to move relative to one another and a second position in which the first shell member and the second shell member are precluded from moving relative to one another, the actuator engaging a point of attachment of the first shell member and the second shell member, the actuator comprising a locking projection configured to lock the first shell member and the second shell member relative to one another by extending through the first shell member to engage the second shell member without extending through the second shell member, the locking projection comprising a top surface that contacts an outer surface of the first shell member when the actuator is moved between the first and second positions such as to exert a threshold resistance on the outer surface of the first shell member.
2. The helmet of claim 1, wherein a ratio of (i) a distance by which the locking projection protrudes into the outer shell when the actuator is in the second position to (ii) a width of the helmet is no more than 1:50.
3. The helmet of claim 2, wherein the ratio of (i) the distance by which the locking projection protrudes into the outer shell when the actuator is in the second position to (ii) the width of the helmet is no more than 1:70.

4. The helmet of claim 1, wherein a distance by which the locking projection protrudes into the outer shell when the actuator is in the second position is no more than 15 mm.
- 5 5. The helmet of claim 4, wherein the distance by which the locking projection protrudes into the outer shell when the actuator is in the second position is no more than 10 mm.
6. The helmet of claim 5, wherein the distance by which the locking projection
10 protrudes into the outer shell when the actuator is in the second position is no more than 5 mm.
7. The helmet of claim 1, wherein the second shell member comprises a locking recess configured to receive the locking projection.
- 15 8. The helmet of claim 1, wherein, when the actuator is in the second position, the locking projection is hidden from view.
9. The helmet of claim 1, wherein, when the actuator is in the first position, the
20 locking projection is visible from an exterior of the helmet.
10. The helmet of claim 1, wherein the helmet comprises protective padding facing an internal surface of the outer shell.
- 25 11. The helmet of claim 10, wherein a thickness of a portion of the protective padding in an area of the helmet opposite the actuator when the actuator is in the second position is at least 5 mm.
12. The helmet of claim 11, wherein the thickness of the portion of the protective
30 padding in the area of the helmet opposite the actuator when the actuator is in the second position is at least 15 mm.

13. The helmet of claim 12, wherein the thickness of the portion of the protective padding in the area of the helmet opposite the actuator when the actuator is in the second position is at least 20 mm.

5

14. The helmet of claim 10, wherein a ratio of (i) a thickness of a portion of the protective padding opposite to the actuator when the actuator is in the second position and (ii) a width of the helmet is at least 0.1.

10 15. The helmet of claim 14, wherein the ratio of (i) the thickness of the portion of the protective padding opposite to the actuator when the actuator is in the second position and (ii) the width of the helmet is at least 0.15.

15 16. The helmet of claim 15, wherein the ratio of (i) the thickness of the portion of the protective padding opposite to the actuator when the actuator is in the second position and (ii) the width of the helmet is at least 0.2.

17. The helmet of claim 1, wherein the actuator is a first actuator located on a first side of the helmet and the adjustment mechanism comprises a second actuator located on a second side of the helmet and movable between a first position in which the first shell member and the second shell member are allowed to move relative to one another and a second position in which the first shell member and the second shell member are precluded from moving relative to one another, the second actuator being configured to lock the first shell member and the second shell member relative to one another by extending through the first shell member to engage the second shell member without extending through the second shell member.

18. The helmet of claim 17, wherein the second actuator comprises a locking projection configured to lock the first shell member and the second shell

30

member relative to one another without extending through the second shell member.

5 19. The helmet of claim 1, wherein the locking projection comprises at least one tooth.

20. The helmet of claim 1, wherein the actuator is pivotally mounted to the outer shell.

10 21. The helmet of claim 1, wherein the adjustment mechanism comprises a plate interconnecting the first and second shell members while allowing slidable movement of the first and second shell members relative to one another to adjust the fit of the helmet on the wearer's head.

15 22. The helmet of claim 1, wherein the locking projection has a height measured in a direction from an upper edge of the actuator to a lower edge of the actuator, a ratio of (i) the height of the locking projection over (ii) a distance by which the locking projection penetrates into the outer shell when the actuator is in the second position is at least 2.

20 23. The helmet of claim 1, wherein a ratio of (i) a width of the locking projection over (ii) a distance by which the locking projection penetrates into the outer shell when the actuator is in the second position is at least 0.5.

25 24. The helmet of claim 23, wherein the ratio of (i) the width of the locking projection over (ii) the distance by which the locking projection penetrates into the outer shell when the actuator is in the second position is at least 1.

30 25. The helmet of claim 1, wherein the locking projection is one of a plurality of locking projections of the actuator.

26. The helmet of claim 25, wherein the plurality of locking projections of the actuator comprises at least three parallel locking projections.

5 27. The helmet of claim 26, wherein the locking projections are evenly spaced from one another.

28. The helmet of claim 26, wherein a distance between adjacent ones of the locking projections is unequal.

10 29. The helmet of claim 25, wherein the second shell member comprises a plurality of locking recesses configured to receive the locking projections.

30. The helmet of claim 7, wherein a thickness of the second shell member in an area occupied by the locking recess is no more than 5 mm.

15

31. The helmet of claim 25, wherein the adjustment mechanism comprises a plurality of openings on the first shell member, the openings being aligned with the locking projections of the actuator.

20 32. The helmet of claim 31, wherein, when the actuator is moved from the first position to the second position, the plurality of locking projections are moved through respective ones of the openings.

25 33. The helmet of claim 29, wherein there are more locking recesses than locking projections.

30 34. The helmet of claim 29, the helmet being adjustable between sizes in which the first and second shell members are at different positions relative to one another, wherein a first set of the locking recesses receive the locking projections when the actuator is placed into the second position while the helmet is adjusted to a first one of the sizes and wherein a second set of the

locking recesses receive the locking projections when the actuator is placed into the second position while the helmet is adjusted to a second one of the sizes.

5 35. The helmet of claim 29, wherein one or more of the locking recesses is pocketed in an outer surface of the second shell member.

36. The helmet of claim 29, wherein adjacent ones of the locking recesses are spaced apart by a certain distance and wherein adjacent ones of the locking
10 projections are spaced apart by a multiple of said certain distance.

37. The helmet of claim 1, wherein the locking projection remains fixed in relation to the point of attachment of the first shell member and the second shell member when the fit of the helmet is adjusted to different sizes.

15

38. The helmet of claim 1, wherein the point of attachment comprises a peg engaging the first shell member and the second shell member.

39. The helmet of claim 1, wherein the locking projection is a first locking
20 projection, the point of attachment is a first point of attachment, the actuator comprises a second locking projection, the actuator engaging a second point of attachment of the first shell member and the second shell member, and the second locking projection is located adjacent to the second point of attachment of the first shell member and the second shell member.

25

40. The helmet of claim 39, wherein, when the actuator is in the second position, at least one of the first and second locking projections is located between the first and second points of attachment of the first shell member and the second shell member.

30

41. The helmet of claim 1, wherein the actuator is a lever.

42. The helmet of claim 1, wherein the adjustment mechanism further comprises a component that, when the actuator is in the second position, sandwiches the second shell member to the first shell member, the component facing an internal surface of the second shell member and having a protrusion that extends through the second shell member and protrudes from the first shell member, wherein the protrusion is the point of attachment of the first shell member and the second shell member.
43. The helmet of claim 42, wherein the actuator is connected to the component at the protrusion and the locking projection is immediately adjacent to the protrusion.
44. A helmet for protecting a wearer's head, the helmet comprising:
- a) an outer shell comprising a first shell member and a second shell member movable relative to one another in a longitudinal direction of the helmet to adjust a size of a cavity for receiving the wearer's head;
 - b) an adjustment mechanism configured to control movement of the first shell member and the second shell member relative to one another, the adjustment mechanism comprising:
 - i) an actuator movable between a first position in which the first shell member and the second shell member are allowed to move relative to one another and a second position in which the first shell member and the second shell member are precluded from moving relative to one another;
 - ii) two points of attachment between the first shell member and the second shell member, the two points of attachment configured to interconnect the first shell member and the second shell member while allowing the first shell member and the second shell member to move relative to one another when the actuator is in the first position; and

iii) a locking recess on an outer surface of the second shell member;
the actuator comprising a locking projection configured such that, when
the cavity is of a first size and the actuator is in the second position, the
locking projection extends through the first shell member at a point located
5 between the two points of attachment interconnecting the first shell member
and the second shell member and is received by the locking recess to lock
the first shell member and the second shell member relative to one another
without extending through the second shell member, wherein the locking
projection is a first locking projection, the actuator comprising a plurality of
10 locking projections, inclusive of the first locking projection, that extend
through the first shell member when the actuator is in the second position,
wherein each locking projection of the plurality of locking projections projects
away from an inner face of the actuator and is disposed between the two
points of attachment interconnecting the first shell member and the second
15 shell member at a different location along the longitudinal direction of the
helmet, wherein adjacent ones of the plurality of locking projections are
joined at upper ends thereof by a surface that projects away from the inner
face of the actuator and extends between the adjacent locking projections in
the longitudinal direction of the helmet.

20

45. The helmet of claim 44, wherein the plurality of locking projections of the
actuator comprises at least three parallel locking projections.

46. The helmet of claim 45, wherein the locking projections are evenly spaced
25 from one another.

47. The helmet of claim 44, wherein the second shell member comprises a
plurality of locking recesses configured to receive the locking projections.

48. The helmet of claim 44, wherein a ratio of (i) a distance by which the first locking projection protrudes into the outer shell when the actuator is in the second position to (ii) a width of the helmet is no more than 1:50.
- 5 49. The helmet of claim 44, wherein a distance by which the first locking projection protrudes into the outer shell when the actuator is in the second position is no more than 15 mm.
50. The helmet of claim 44, wherein, when the actuator is in the second position,
10 the first locking projection is hidden from view.
51. The helmet of claim 50, wherein, when the actuator is in the first position, the first locking projection is visible from an exterior of the helmet.
- 15 52. The helmet of claim 44, wherein the helmet comprises protective padding facing an internal surface of the outer shell, wherein a thickness of a portion of the protective padding in an area of the helmet opposite the actuator when the actuator is in the second position is at least 5 mm.
- 20 53. The helmet of claim 52, wherein a ratio of (i) a thickness of a portion of the protective padding opposite to the actuator when the actuator is in the second position and (ii) a width of the helmet is at least 0.1.
54. The helmet of claim 44, wherein:
25 the actuator is a first actuator located on a first side of the helmet;
the two points of attachment between the first shell member and the second shell member are a first two points of attachment located on the first side of the helmet;
the locking recess is a first locking recess on the outer surface of the
30 second shell member on the first side of the helmet, the first two points of attachment configured to interconnect the first shell member and the second

shell member and allow the first shell member and the second shell member to move relative to one another when the first actuator is in the first position; and

the adjustment mechanism further comprises:

- 5 i) a second actuator located on a second side of the helmet and movable between a first position in which the first shell member and the second shell member are allowed to move relative to one another and a second position in which the first shell member and the second shell member are precluded from moving relative
- 10 to one another;
- ii) a second two points of attachment between the first shell member and the second shell member on the second side of the helmet, the second two points of attachment configured to interconnect the first shell member and the second shell member
- 15 and allow the first shell member and the second shell member to move relative to one another when the second actuator is in the first position; and
- iii) a second locking recess on the outer surface of the second shell member on the second side of the helmet;

20 the second actuator comprising a locking projection configured such that, when the cavity is of the first size and the second actuator is in the second position, the locking projection on the second actuator extends through the first shell member at a point located between the second two points of attachment interconnecting the first shell member and the second shell

25 member on the second side of the helmet and is received by the second locking recess to lock the first shell member and the second shell member relative to one another without extending through the second shell member.

30 55. The helmet of claim 44, wherein the actuator is pivotally mounted to the outer shell.

56. The helmet of claim 44, wherein the locking recess is pocketed in an outer surface of the second shell member.

57. The helmet of claim 44, wherein when the actuator is in the second position,
5 the two points of attachment between the first shell member and the second shell member are covered by the actuator such that the two points of attachment are hidden from view by the actuator when the actuator is in the second position.

10 58. The helmet of claim 44, wherein the locking projection remains fixed in relation to the two points of attachment between the first shell member and the second shell member when the size of the cavity is adjusted to different sizes.

15 59. The helmet of claim 57, wherein the actuator is received in a recessed region of the first shell member when the actuator is in the second position, wherein the two points of attachment between the first shell member and the second shell member extend through openings in the first shell member located in the recessed region of the first shell member.

20

60. The helmet of claim 57 wherein when the actuator is in the first position, external end portions of the two points of attachment between the first shell member and the second shell member are visible.

25 61. A helmet for protecting a wearer's head, the helmet comprising:
a) an outer shell comprising a first shell member and a second shell member movable relative to one another in a longitudinal direction of the helmet to adjust a size of a cavity for receiving the wearer's head;
b) an adjustment mechanism configured to control movement of the first
30 shell member and the second shell member relative to one another, the adjustment mechanism comprising:

- 5
- i) an actuator movable between a first position in which the first shell member and the second shell member are allowed to move relative to one another and a second position in which the first shell member and the second shell member are precluded from moving relative to one another;
- 10
- ii) two points of attachment between the first shell member and the second shell member, the two points of attachment configured to interconnect the first shell member and the second shell member while allowing the first shell member and the second shell member to move relative to one another when the actuator is in the first position; and
- 15
- iii) a locking recess on an outer surface of the second shell member; the actuator comprising a locking projection configured such that, when the cavity is of a first size and the actuator is in the second position, the locking projection extends through the first shell member at a point located
- 20
- between the two points of attachment interconnecting the first shell member and the second shell member and is received by the locking recess to lock the first shell member and the second shell member relative to one another without extending through the second shell member, wherein the locking projection is a first locking projection, the actuator comprising a plurality of locking projections, inclusive of the first locking projection, that extend
- 25
- through the first shell member when the actuator is in the second position, wherein the plurality of locking projections comprises a second locking projection configured such that, when the cavity is of a second size and the actuator is in the second position, the second locking projection extends
- 30
- through the first shell member at a point located between the two points of attachment interconnecting the first shell member and the second shell member and is received by the locking recess to lock the first shell member and the second shell member relative to one another without extending through the second shell member, wherein the first and second locking projections are joined at upper ends thereof by a surface that projects away

from the inner face of the actuator and extends between the first and second locking projections in the longitudinal direction of the helmet.

5 62. The helmet of claim 61, wherein when the actuator is in the second position, the two points of attachment between the first shell member and the second shell member are covered by the actuator such that the two points of attachment are hidden from view by the actuator when the actuator is in the second position.

10 63. The helmet of claim 62, wherein the actuator is received in a recessed region of the first shell member when the actuator is in the second position, wherein the two points of attachment between the first shell member and the second shell member extend through openings in the first shell member located in the recessed region of the first shell member.

15

64. The helmet of claim 62 wherein when the actuator is in the first position, external end portions of the two points of attachment between the first shell member and the second shell member are visible.

+

1/14

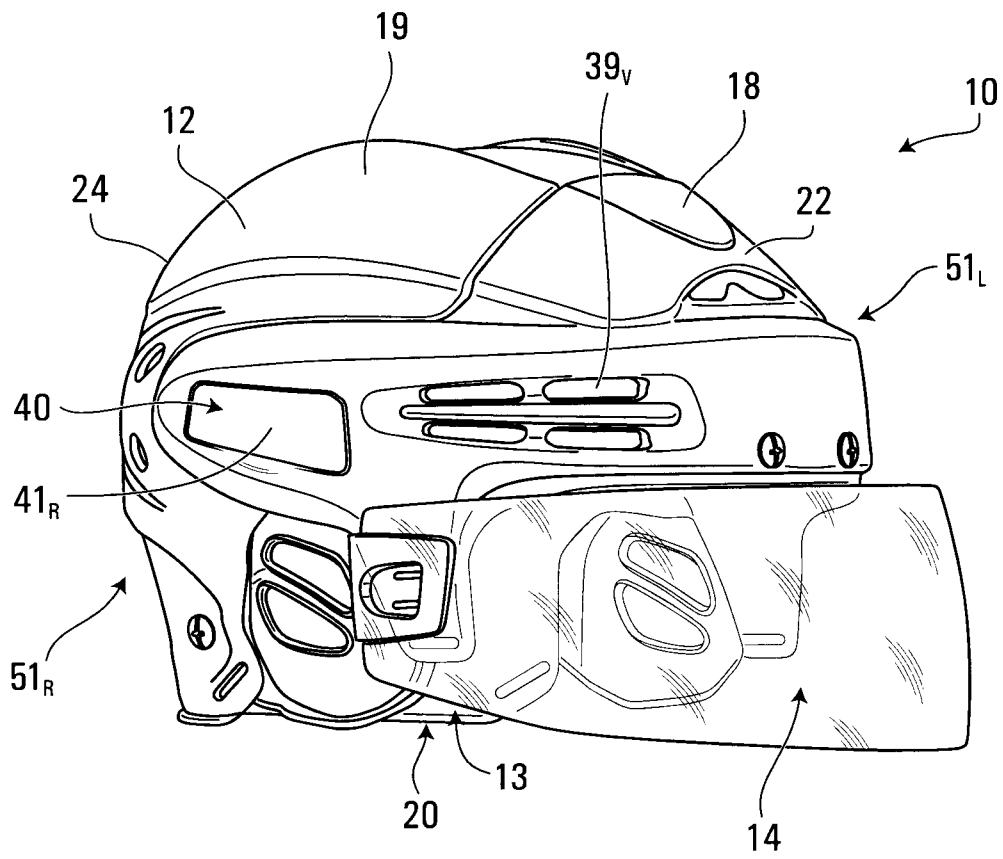

FIG. 1

+

+

2/14

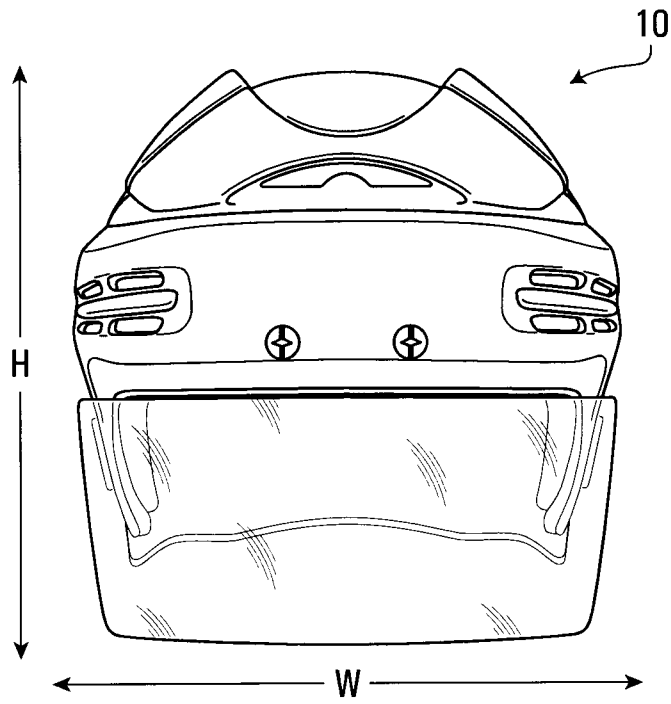

FIG. 2

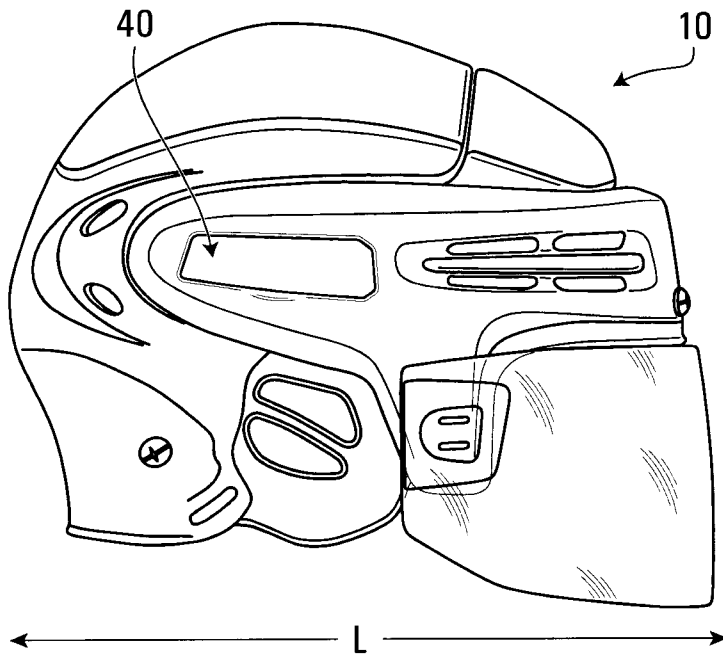

FIG. 3

+

+

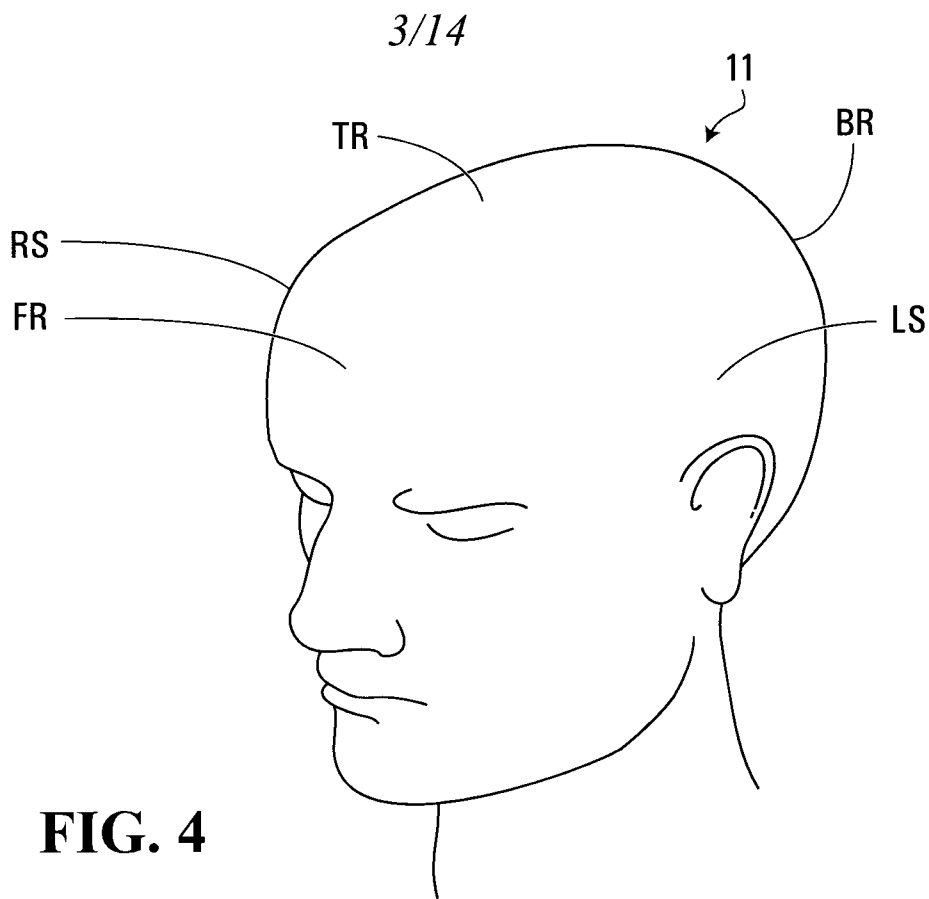

FIG. 4

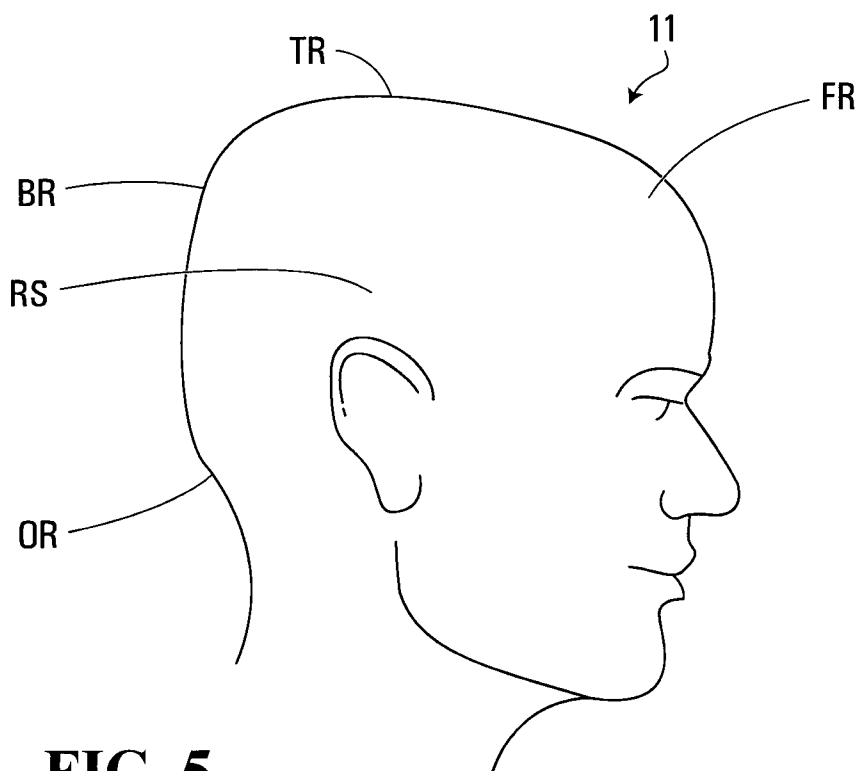

FIG. 5

+

+

4/14

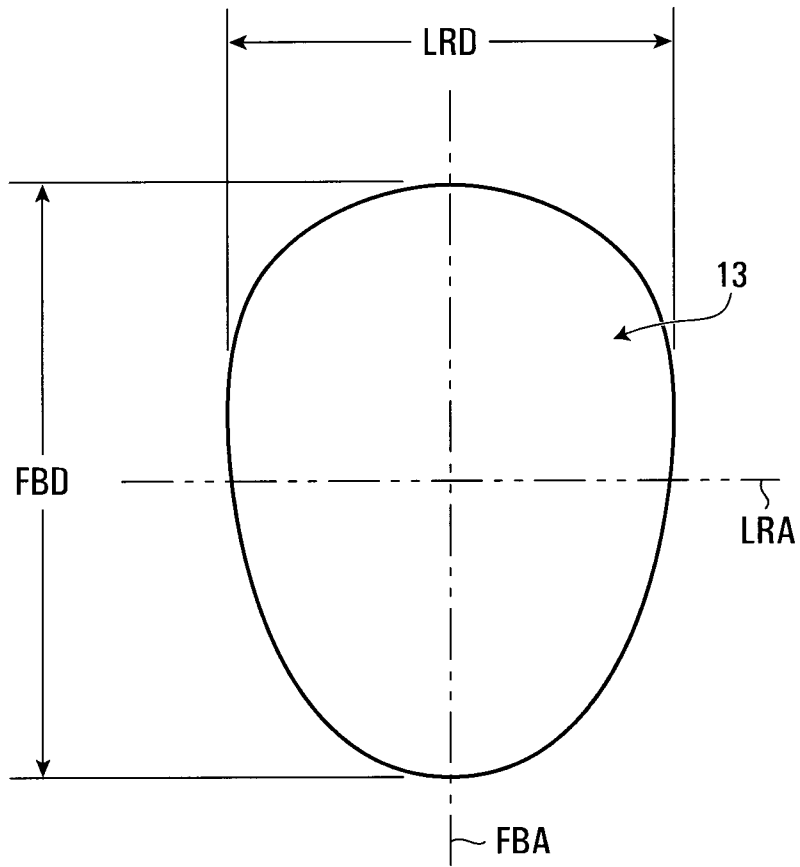
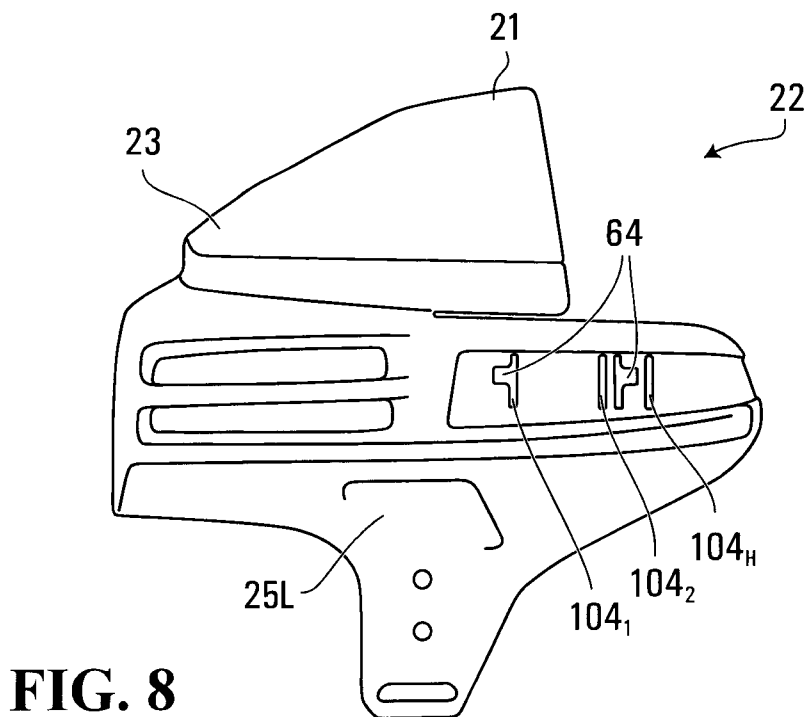
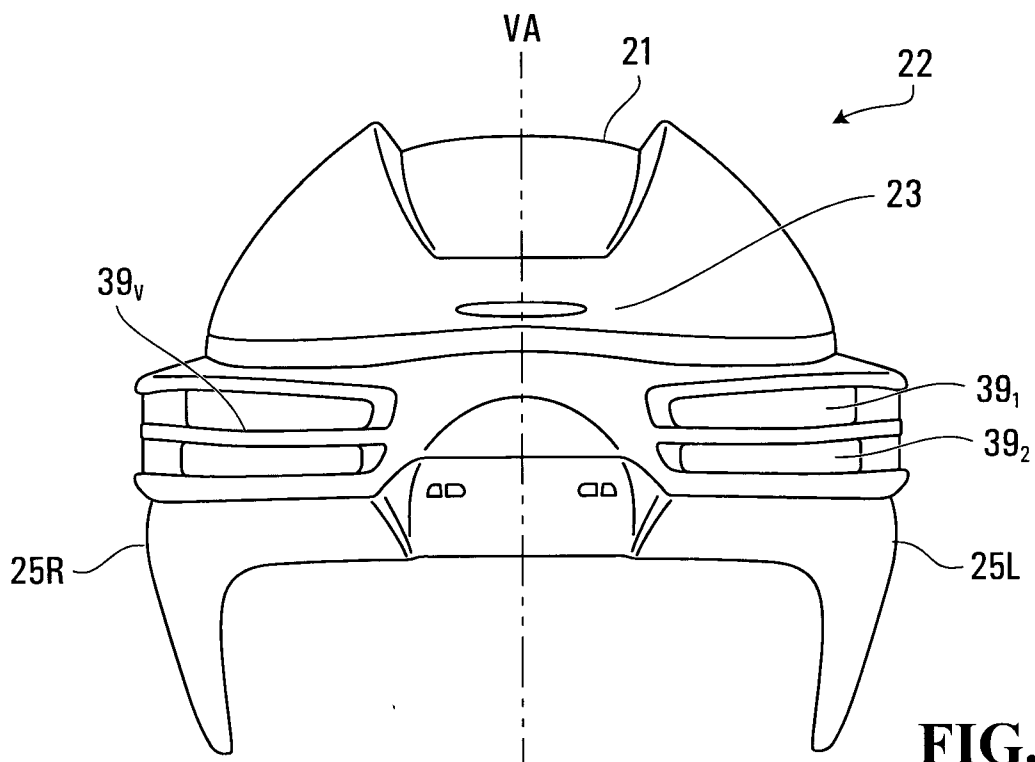

FIG. 6

+

+

5/14



+

+

6/14

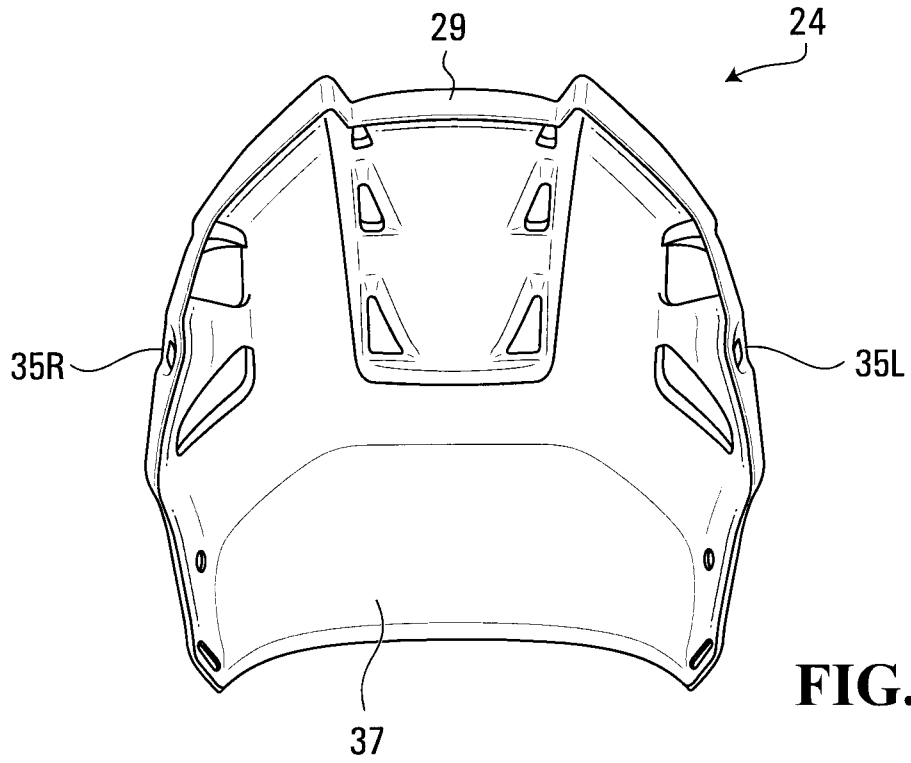

FIG. 9

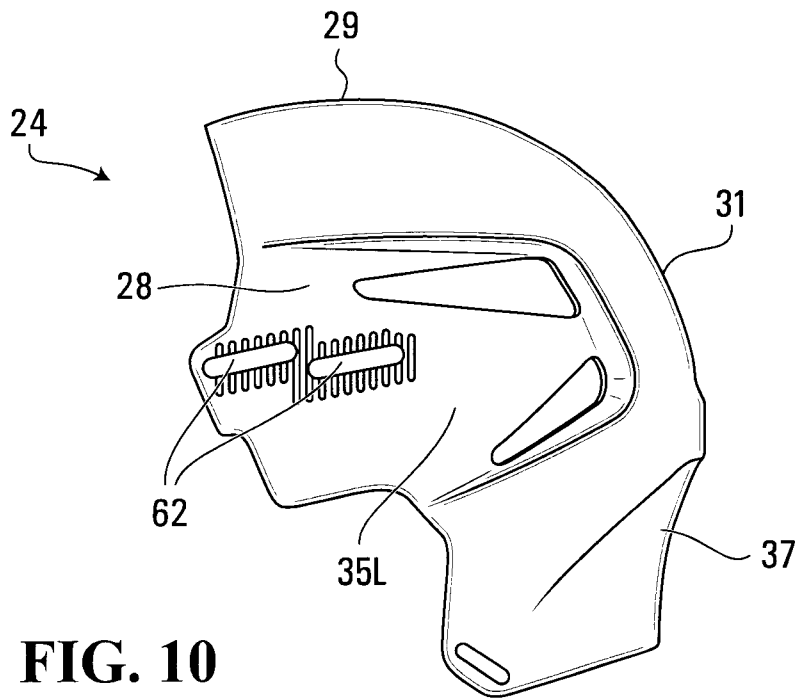

FIG. 10

+

+

8/14

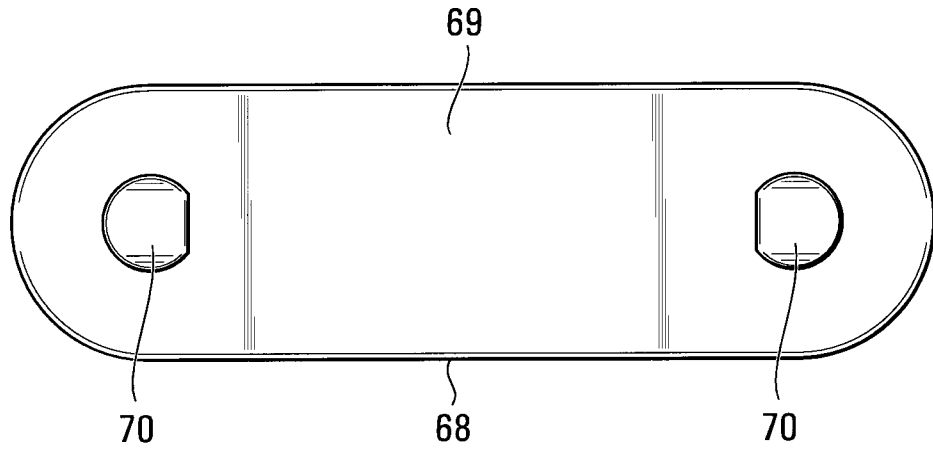

FIG. 12

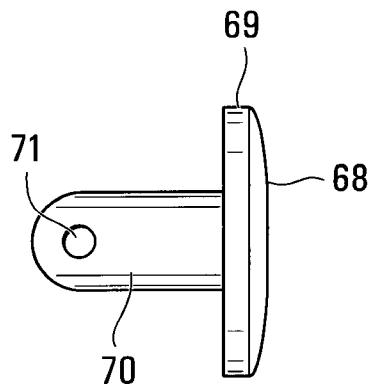

FIG. 13

+

+

9/14

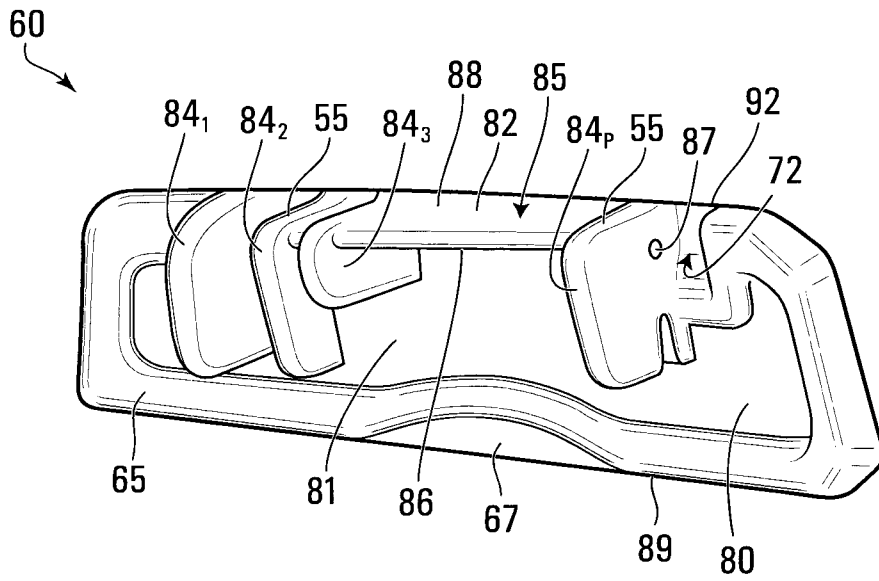

FIG. 14

+

+

10/14

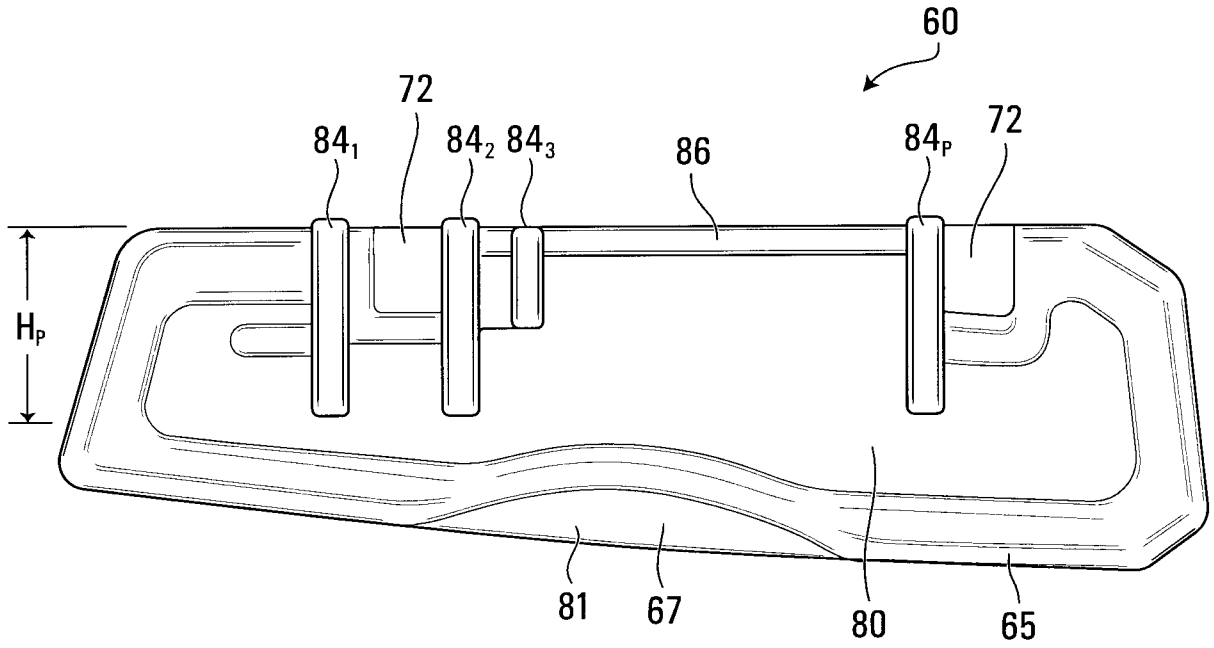

FIG. 15

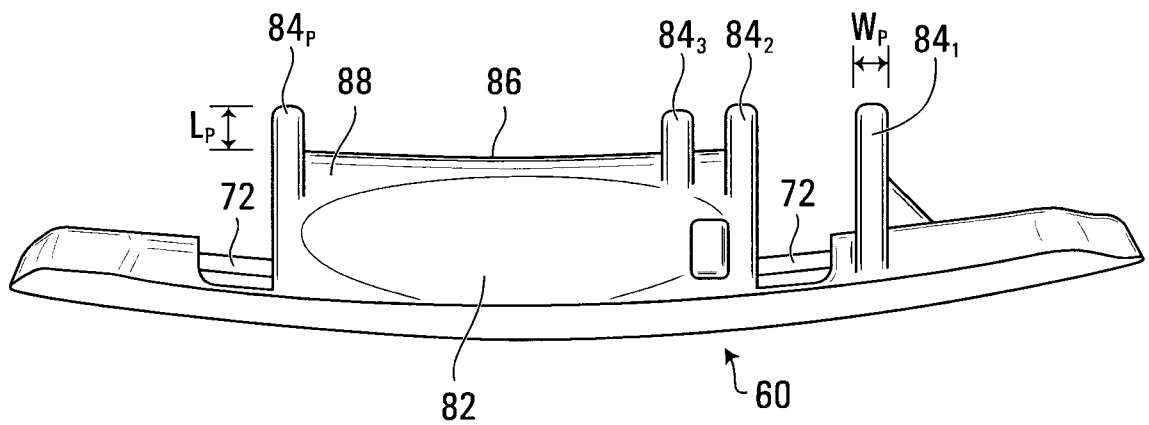

FIG. 16

+

+

11/14

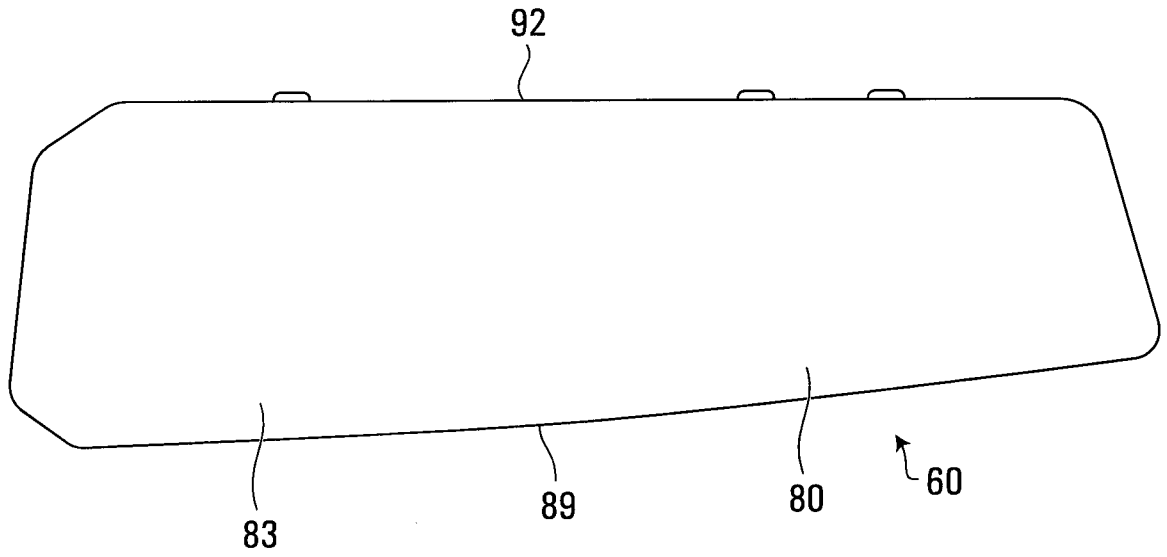

FIG. 17

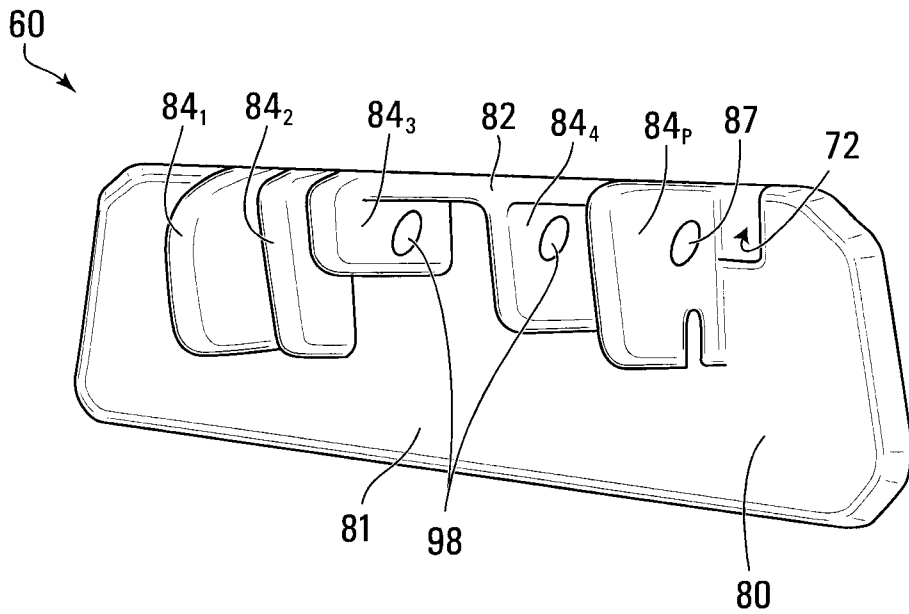

FIG. 18

+

+

12/14

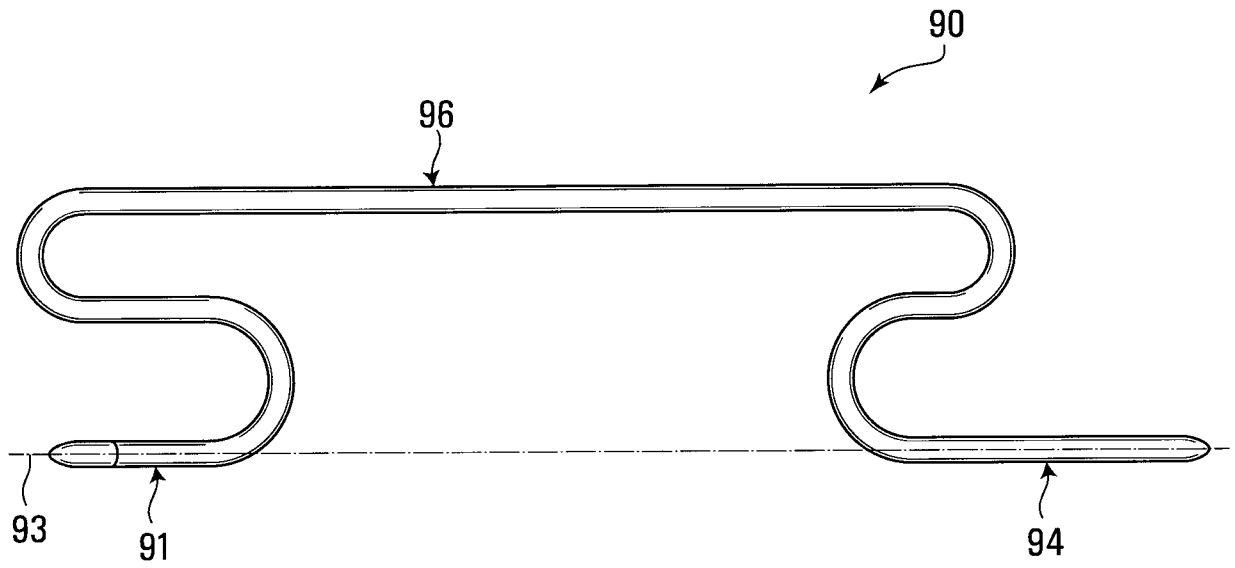

FIG. 19

+

+

14/14

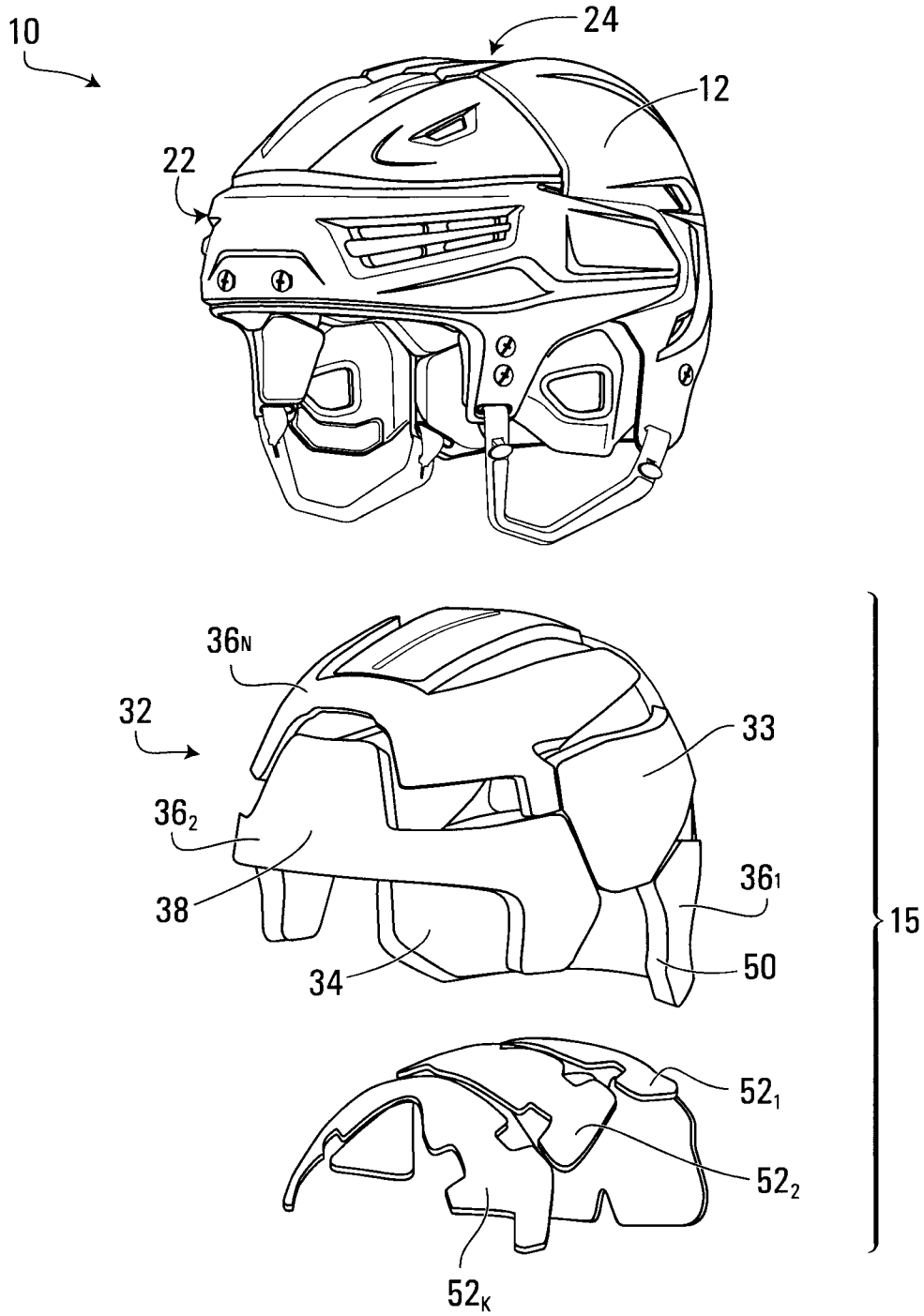

FIG. 22

+

