

Oct. 20, 1936.

R. W. ROSENDALE

2,058,263

CABINET

Filed July 11, 1935

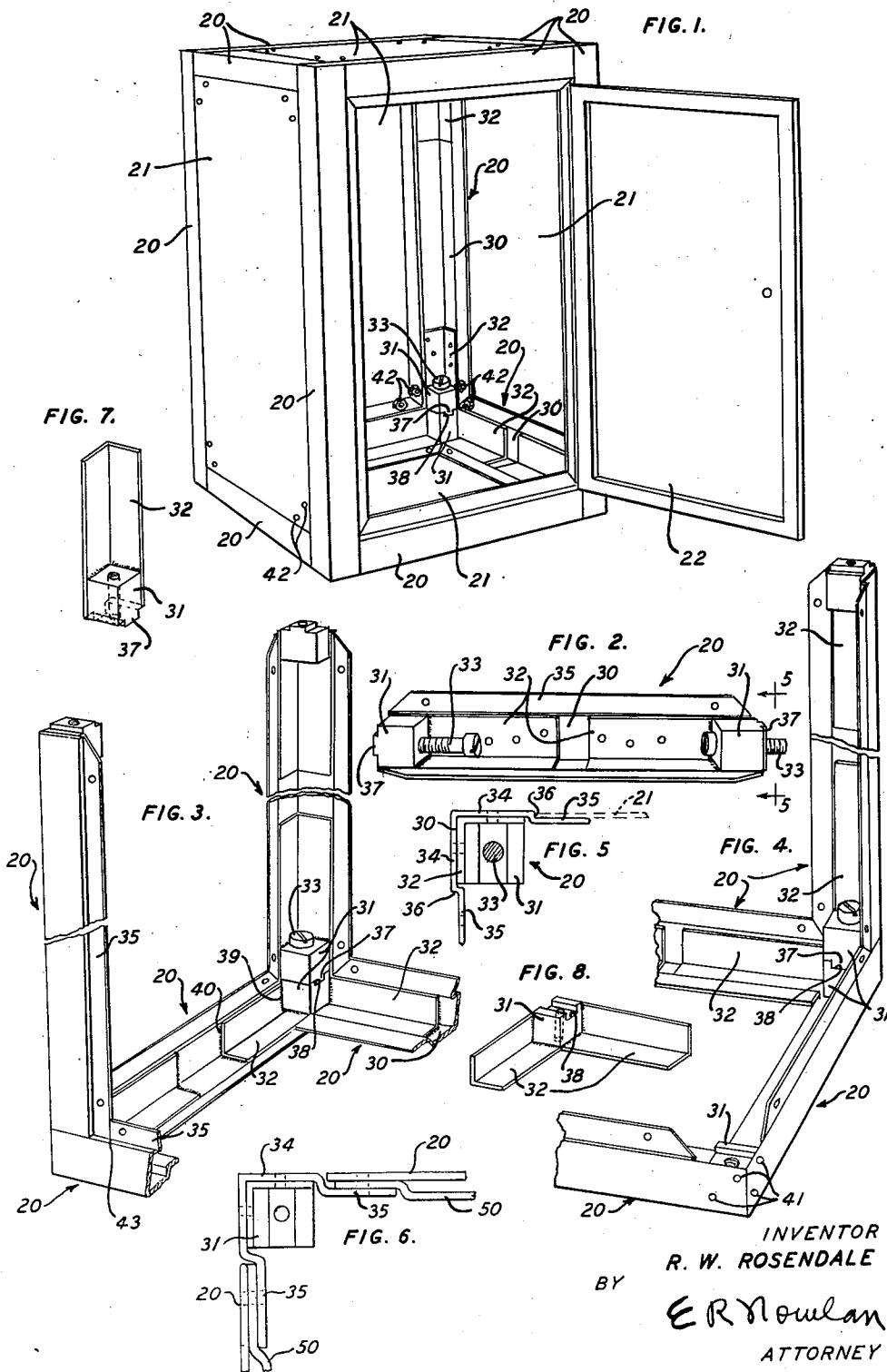

# UNITED STATES PATENT OFFICE

2,058,263

## CABINET

Robert W. Rosendale, Westfield, N. J., assignor to  
Western Electric Company, Incorporated, New  
York, N. Y., a corporation of New York

Application July 11, 1935, Serial No. 30,858

12 Claims. (Cl. 312-143)

This invention relates to cabinets and more particularly to cabinets constructed principally of prefabricated units adapted to be assembled to form cabinets of a large range of sizes and proportions and particularly adapted to mount and protect electrical apparatus.

Apparatus for use in the communications art, especially for wire and wireless telegraphic and telephonic use, and a large variety of analogous assemblies of apparatus, are frequently installed for security and convenience in cabinets comprising a metal framework and panels and doors of metal or of insulating material such as wood, artificial resin, stone, artificial mineral material and the like. In some instances it is desirable that the cabinet and the apparatus to be housed therein be shipped from the place of manufacture to a place of temporary or permanent installation in disassembled parts for assembly at the destination. In other instances it may be preferred to assemble the cabinet, install the apparatus therein and ship as a unit. In either case it may frequently be true that the particular apparatus is unique in the dimensions and proportions of the space required within the cabinet to house it.

One object of the present invention is to provide a cabinet comprising prefabricated parts, which can be assembled into cabinets of a large range of proportions and dimensions with a minimum of cutting and fitting.

One embodiment of the invention contemplates a framework for a cabinet of prismatic form having edge units of metal comprising body members of sheet metal having two flanges integrally joined as an angle and each flange comprising two parallel plane portions integrally united by a strip transverse thereto; and preformed connecting blocks to be positioned within the body members and provided with one or two angle member extensions for attachment to the inner faces of the body members, the blocks being provided with means to secure two such blocks together and to position two such blocks accurately relatively to each other when abutted.

Other objects and features of the invention will clearly appear from the following detailed description of one embodiment thereof taken in connection with the accompanying drawing in which like reference numerals are applied to identical parts in the several figures and in which

Fig. 1 is a perspective view in elevation of a cabinet constructed in accordance with the invention;

Fig. 2 is a similar view of one edge unit thereof;

Fig. 3 is a similar broken view of a part of the frame of the cabinet;

Fig. 4 is a similar broken view of another part of the frame of the cabinet;

Fig. 5 is a sectional view on the line 5-5 of Fig. 2;

Fig. 6 is a view analogous to Fig. 5 of a modified form;

Fig. 7 is a view analogous to Fig. 2 of a construction unit, and

Fig. 8 is a similar view of another construction unit.

In the embodiment of the invention herein disclosed, a cabinet as shown in Fig. 1 comprises twelve edge units 20, five panels 21 mounted on the edge units, and a door 22 also mounted on one of the edge units. Certain edge units are constructed substantially as shown in Fig. 2, and each of these comprises a principal or body member 30, a pair of connecting blocks 31, 31, angle extensions 32, 32 interposed between the blocks and the body, and means such as the screws 33, 33, for attaching each block to another such block.

The body member 30 is generally a right angle in cross section comprising two longitudinal flanges formed integrally from one piece of sheet metal. Each of these two flanges comprises two longitudinally extending parallel plane strips 34 and 35, of which the outer one 35 is offset toward the interior of the angle relatively to the inner one 34, the two being joined by a relatively narrow strip 36 perpendicular to both.

Each of the blocks 31 is a generally rectangularly parallelepipedal piece of metal, provided on one face with a transverse tongue 37 or a transverse groove 38, and each is bored and tapped to receive a screw 33.

To each block 31 in the structure shown in Fig. 2, is secured an angle extension 32, which is a piece of sheet metal bent into a plane-sided dihedral angle having two flanges at right angles to each other. The width of these flanges is preferably, though not necessarily, such that each flange will fit easily against the inner face of one of the strips 34 of the member 30 and between the other strip 34 and the strip 36 opposite thereto, and may be secured to the member 30 in such position.

These parts may be secured together by any suitable means, a satisfactory method being to spot weld the extension 32 to the block 31 and the member 30 to the extension 32. The block

might also be arc or acetylene welded to the extension as indicated at 39 (Fig. 3) and the extension similarly welded to the member as at 40 (Fig. 3). For some cases it may be preferable to secure the parts together as indicated at 41 in Fig. 4 by means of independent fasteners such as rivets, bolts, screws entering tapped holes in the block, or screws of hardened metal which will cut their own threads into the wall of previously bored holes.

In the particular cabinet shown, the four upright edge units 20 are constructed as shown in Fig. 2 and so are completely independent and may be removed from and replaced in the frame at will by means of the screws 33. The four horizontal edge units 20 which form the rectangular bottom of the frame, have only four corner blocks between them and each block is provided with two angle members 32 positioned at right angles to each other, as best seen in Fig. 3, and secured respectively to two neighboring body members 30. Thus these four bottom horizontal edge units 20 are united into one rigid bottom frame unit. In the same way the four horizontal upper units 20 are joined into one rigid top frame unit.

The panels 21 rest with the peripheral portions of their inner faces against the outer faces of the strips 35 as indicated in dotted lines in Fig. 5, and are secured to the strips 35 in any suitable fashion, as by bolts 42 (Fig. 1), or if permanency be desired by spot welding. The offset at 36 of the strip 35 with respect to the strip 34 may well be merely such that the outer face of the panel will be flush with the outer face of the strip 34, or it may be greater as indicated in Fig. 6 where the end of a support 50 is shown as secured between the strip 35 and the panel 20. The support 50 is a flat bar offset at each end and secured in place as shown preferably by being spot welded, riveted or bolted to the strip 35 and to the panel 20 for use in supporting apparatus to be housed in the cabinet.

The ends of the strips 35 may preferably be bevelled as shown in Fig. 2 or may be matched as indicated at 43 in Fig. 3.

In practice, in the manufacture of many kinds of apparatus, especially of apparatus for telephone, radio, public address and analogous uses where complex and delicate systems of electrical elements of various kinds are to be securely and sometimes also transportably housed, it may be desired to provide cabinets therefor of uniform type of appearance, although of variable dimensions and proportions. To this end, and to provide means for rapidly and easily manufacturing such cabinets to order to fit individually differing contents, following the present invention, there may be manufactured at one time and held in stock a supply of intermediate units such as shown in Figs. 7 and 8, comprising each a block 31 with one or two, as the case may be, extension members 32 secured thereto, with a corresponding supply of assembly screws 33. There will then also be provided a supply of preformed pieces having the cross section of the body members 30 shown in Fig. 5, comprising the strips 34, 35 and 36, and formed in any convenient lengths. Panel material is also provided in flat sheets.

When it is then desired to construct a cabinet of specified dimensions, it is only necessary to cut body members 30 to the required lengths, and to shear the panel sheets to corresponding size. Units such as shown in Fig. 2 and in the lower

parts of Figs. 3 and 4 may then be easily and rapidly assembled. The whole cabinet may then be shipped in knockdown form to the point of use and assembled there without manufacturing operations by the use of screws 41, or may be permanently assembled complete with screws or by welding before being shipped.

Generally it is preferable in making up units such as shown in Fig. 2 or in the bottom parts of Figs. 2 and 3, to orient the tongues and grooves 37 and 38 at right angles to each other at consecutive corners of the cabinet, as this helps to increase the rigidity of the assembled cabinet and also the ease of assembly.

By using removable fastenings such as bolts or screws at the points 41 and 42, the parts of the cabinet may be compactly packed for shipment in knockdown condition, to be assembled at the point of use and there receive apparatus to be housed therein. On the other hand it is in some instances desirable to install apparatus in the cabinet for shipment therein and to be protected thereby. In such case the cabinet may be assembled and the parts permanently and rigidly secured together by rivets or, preferably, by spot welding at the points 41 and 42.

The embodiment of the invention herein disclosed is illustrative only and may be widely modified and departed from in many ways without departing from the spirit and scope of the invention as pointed out in and limited only by the appended claims.

What is claimed is:

1. In a cabinet, a compound edge member comprising an angle member body of sheet metal, an intermediate angle member fitted therein and secured thereto with the entire exterior surface of the intermediate angle member engaging both inner surfaces of the first mentioned angle member body, and a block connecting member fitted in and secured to the intermediate member.

2. In a cabinet, a compound edge member comprising an angle member body of sheet metal, an intermediate angle member fitted therein and secured thereto with the entire exterior surface of the intermediate angle member engaging both inner surfaces of the first mentioned angle member body, a block connecting member fitted in and secured to the intermediate member and having a surface conformation to interlock with the complementary surface conformation on another block, and means to secure the block to such other block.

3. In a cabinet, a compound edge member comprising an angle member body of sheet metal, an intermediate angle member fitted therein and secured thereto, a block connecting member fitted in and secured to the intermediate member, and means to secure the block to another such block comprising a tongue and groove member on the block and a screw mounted in the member.

4. In a cabinet, a compound edge member comprising an angle member body of sheet metal comprising two longitudinally offset flanges, an intermediate angle member fitting into the internal recesses thereof and secured thereto, and a block connecting member fitted in and secured to the intermediate member.

5. In a cabinet, a compound edge member comprising an externally recessed angle member body of sheet metal, an intermediate angle member fitted therein and secured thereto with the entire exterior surface of the intermediate angle member engaging both inner surfaces of the first

mentioned angle member body, a block connecting member fitted in and secured to the intermediate member, and a sheet metal panel secured to the angle member body in the external recess thereof.

5 6. In a cabinet, a compound edge member comprising an angle member body of sheet metal comprising two longitudinally recessed flanges, an intermediate angle member fitting into the internal recesses thereof and secured thereto, a block connecting member fitted in and secured to the intermediate member, and a sheet metal panel secured to the angle member body in an external recess thereof.

10 7. In a cabinet, a compound edge member comprising an angle member body of sheet metal comprising two longitudinally recessed flanges, an intermediate angle member fitting into the internal recesses thereof and secured thereto, a block connecting member fitted in and secured to the intermediate member, a sheet metal panel secured to the angle member body in an external recess thereof, and a support secured to the angle member body and to the panel between the same.

15 8. In a cabinet, a structural unit thereof having four compound edge members abutted end to end in a rectangle and each comprising an angle member body of sheet metal and two intermediate angle members each fitted into one end of the body and secured thereto, and a block connecting member fitted into each corner of the rectangle and secured to the adjacent intermediate members.

20 9. In a cabinet, a structural unit thereof having four compound edge members abutted end to end in a rectangle and each comprising an angle member body of sheet metal and two intermedi-

ate angle members each fitted into one end of the body and secured thereto, and a block connecting member fitted into each corner of the rectangle and secured to the adjacent intermediate members and provided with means to attach the block to another similar block located outside the plane of the rectangle.

5 10. In a cabinet, a structural unit thereof having four compound edge members abutted end to end in a rectangle and each comprising an angle member body of sheet metal and two intermediate angle members each fitted into one end of the body and welded thereto, and a block connecting member fitted into each corner of the rectangle and welded to the adjacent intermediate members.

10 11. In a cabinet, a structural unit thereof having four compound edge members abutted end to end in a rectangle and each comprising an angle member body of sheet metal and two intermediate angle members each fitted into one end of the body and welded thereto, and a block connecting member fitted into each corner of the rectangle and welded to the adjacent intermediate members and provided with means to attach the block to another similar block located outside the plane of the rectangle.

15 12. In a cabinet, a compound edge member comprising an angle member body of sheet metal, an intermediate angle member fitted therein and secured thereto, and a block connecting member fitted in and secured to the intermediate member at each end thereof, each block having tongue and groove means thereon for cooperation with similar means on another block, and the said means on the two said blocks extending in mutually perpendicular directions.

20 25 30 35  
ROBERT W. ROSENDALE.