

H. Dusch,

Hulling Mach.

No. 102622,

Patented Oct. 25. 1870.

Fig. 1

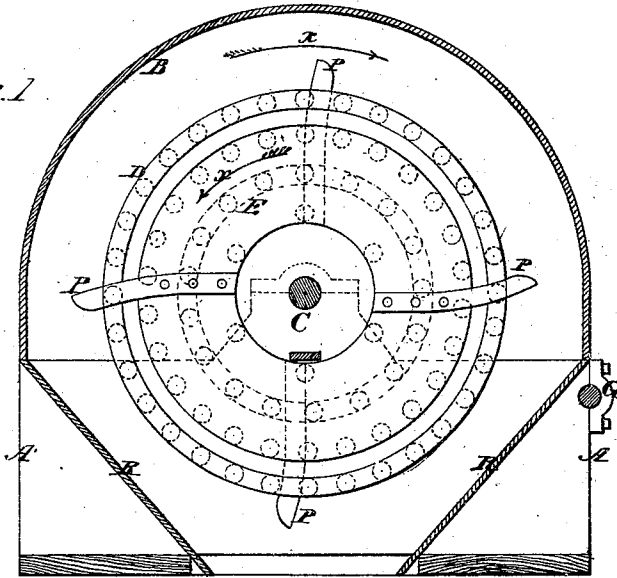

Fig. 2

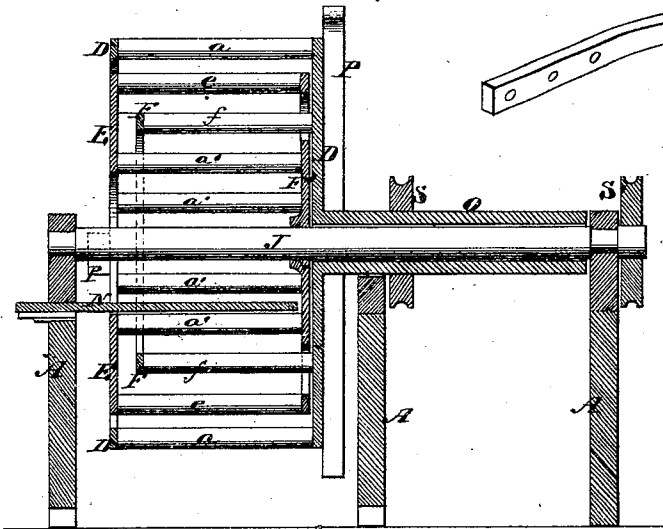

Fig. 3



Witnesses:  
R. Campbell  
J. C. Campbell

Inventor  
Henry Dusch  
by his atty  
Marion Hancock

# United States Patent Office.

HENRY DUCSH, OF BALTIMORE, MARYLAND.

Letters Patent No. 108,692, dated October 25, 1870.

## IMPROVEMENT IN ROTARY DISINTEGRATORS.

The Schedule referred to in these Letters Patent and making part of the same.

To all whom it may concern:

Be it known that I, HENRY DUCSH, of Baltimore, in the county of Baltimore and State of Maryland, have invented an Improvement in Rotary Disintegrators; and I do hereby declare that the following is a full, clear, and exact description thereof, reference being had to the accompanying drawing making part of this specification, in which—

Figure 1 is a sectional view of a rotary disintegrator having my improvement applied to it.

Figure 2 is a transverse section taken in a vertical plane through the disintegrator a little on one side of the center thereof.

Similar letters of reference indicate corresponding parts in the several figures.

This invention relates to an improvement on rotary disintegrators which are designed for pulverizing bones, phosphates, and other substances used for fertilizers and other purposes, and which consists of a number of concentric circles of bars, rotating in opposite directions to one another, and with great velocity.

The object of my invention is to improve machines of this kind by applying clearers to the sides of the rotary cylinders, in the spaces between the latter and the case which incloses them, thereby preventing the accumulation of the reduced material in said spaces, and the consequent clogging of the machine, as will be hereinafter explained.

To enable others skilled in the art to understand my invention I will describe its construction and operation.

In the accompanying drawing—

A represents a strong frame, which is adapted to support and partially contain a series of rotary disintegrators and the devices for driving the same.

The disintegrators consist of a number of bars, *a e f a'*, arranged in circles concentric to a shaft, J, and rotating in opposite directions.

The bars *a f* are applied to heads D D' F, which are connected to a sleeve, O, surrounding shaft J, and rotated in the direction indicated by the arrow *x* in fig. 1.

The bars *e* and *a'* are applied to heads E and F', which are connected to the shaft J, and rotated in the direction indicated by the arrow *x'* in fig. 1.

Within the concentric circle of bars *a'* is a knife or breaker, N, which is adjustably secured to the frame A in a rigid position, so that the material when first fed into the machine will be forcibly brought against said breaker and crushed.

On the sleeve O is a pulley, S, which, by means of a crossed belt passed around a pulley on shaft, gives to this sleeve a rotary motion in the direction of arrow *x*; another pulley on shaft G communicates rotary motion to the shaft J, in the direction indicated by arrow *x'*, by means of a belt which is passed around pulley S', and which is not crossed.

The semicircular case B incloses the disintegrators and prevents the material being reduced from flying off.

The inclined planes R R conduct the reduced material down to elevators, which convey it to screens that separate the fine grains from the coarser ones.

The machine which I have above described is liable to one objection, to wit: while reducing moist material it accumulates between the ends of the disintegrators and the case B and frame A, so as to become compacted and so solid that, finally, the machine will stop, and the attendants have to remove the case B and knock out the packed material.

This difficulty is experienced in working the machines more particularly in damp weather, while reducing some of the superphosphates, which deliquesce and become very moist and adherent.

To remedy this objection, I apply to the ends or sides of the disintegrators blades P P, which will operate as clearers, and prevent any accumulation in the spaces between the ends of the disintegrators and the frame A and case B, of the material which is being ground. These clearers P are secured fast to the heads E and D', and may extend out beyond the circumference of the heads D D'; they may be curved, as shown in figs. 1 and 3, and they are preferably made of steel on account of its superior durability.

I do not confine myself to the precise form of the clearers shown in the drawing, nor to any definite number; but I have found that two clearers at opposite ends of the disintegrators will prevent clogging and allow the mill to run smoothly and without loss of power.

Having described my invention,

What I claim as new, and desire to secure by Letters Patent, is—

In the disintegrating-mill, such as described, the arrangement of clearers P, between the casing B and cylinder-head or heads D D', substantially as and for the purpose described.

HENRY DUCSH.

Witnesses:

JAS. R. CLARIDGE.

A. L. GETTY.