



- (51) **International Patent Classification:**
E05C 9/00 (2006.01) *F16H 63/34* (2006.01)
- (21) **International Application Number:**
PCT/IB2020/053191
- (22) **International Filing Date:**
03 April 2020 (03.04.2020)
- (25) **Filing Language:** English
- (26) **Publication Language:** English
- (30) **Priority Data:**
201941013583 04 April 2019 (04.04.2019) IN
- (71) **Applicant: SUPRAJIT ENGINEERING LIMITED**
[IN/IN]; No. 100, Bommasandra industrial area, Bangalore 560099 (IN).
- (72) **Inventors: SCHAEFFER, Scott;** 2533, S West St, Wichita, Kansas, Wichita, Indiana 67217 (US). **ANAND, Pancham Koorana;** Suprajit Engineering Limited, No. 100, Bommasandra industrial area, Bangalore 560099 (IN).
- (74) **Agent: KALIA, Anita et al.;** #213, Sobha Aquamarine, Sarjapur Outer Ring Road, Bellandur, Bangalore - Karnataka 560103 (IN).

(81) **Designated States** (*unless otherwise indicated, for every kind of national protection available*): AE, AG, AL, AM, AO, AT, AU, AZ, BA, BB, BG, BH, BN, BR, BW, BY, BZ, CA, CH, CL, CN, CO, CR, CU, CZ, DE, DJ, DK, DM, DO, DZ, EC, EE, EG, ES, FI, GB, GD, GE, GH, GM, GT, HN, HR, HU, ID, IL, IN, IR, IS, JO, JP, KE, KG, KH, KN, KP, KR, KW, KZ, LA, LC, LK, LR, LS, LU, LY, MA, MD, ME, MG, MK, MN, MW, MX, MY, MZ, NA, NG, NI, NO, NZ, OM, PA, PE, PG, PH, PL, PT, QA, RO, RS, RU, RW, SA, SC, SD, SE, SG, SK, SL, ST, SV, SY, TH, TJ, TM, TN, TR, TT, TZ, UA, UG, US, UZ, VC, VN, WS, ZA, ZM, ZW.

(84) **Designated States** (*unless otherwise indicated, for every kind of regional protection available*): ARIPO (BW, GH, GM, KE, LR, LS, MW, MZ, NA, RW, SD, SL, ST, SZ, TZ, UG, ZM, ZW), Eurasian (AM, AZ, BY, KG, KZ, RU, TJ, TM), European (AL, AT, BE, BG, CH, CY, CZ, DE, DK, EE, ES, FI, FR, GB, GR, HR, HU, IE, IS, IT, LT, LU, LV, MC, MK, MT, NL, NO, PL, PT, RO, RS, SE, SI, SK, SM, TR), OAPI (BF, BJ, CF, CG, CI, CM, GA, GN, GQ, GW, KM, ML, MR, NE, SN, TD, TG).

(54) **Title:** AN ASSEMBLY FOR SECURING A FERRULE TO A GEAR-BOX USING A SPRING-LOADED LOCK PIN

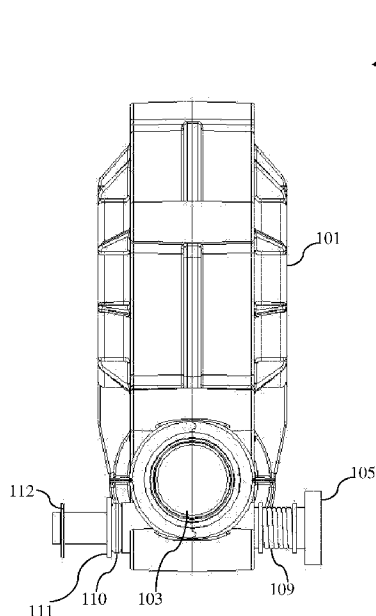

FIGURE 1

(57) **Abstract:** The present invention provides an assembly (100) for securing a gear-box (101) using a spring-loaded lock pin (105) wherein the gear-box (101) is locked with a ferrule (103) by means of a spring-loaded lock pin (105) which enables lock and unlock of the ferrule (103) through a 'press and release' mechanism. The spring-loaded lock pin (105) comprises an internal keyway (106) for facilitating anti-rotational movement of spring-loaded lock pin (105) and slot recess (107) for enabling hassle-free lock and unlock between the ferrule (103) and the gear-box (101). Further, external keyway (102) provided in the gear-box (101) mates with the internal keyway (106) etched in the spring-loaded lock pin (105) for facilitating anti-rotational movement of spring-loaded lock pin (105) under locked and unlocked condition of the ferrule (103).



Published:

- *with international search report (Art. 21(3))*
- *before the expiration of the time limit for amending the claims and to be republished in the event of receipt of amendments (Rule 48.2(h))*
- *in black and white; the international application as filed contained color or greyscale and is available for download from PATENTSCOPE*

TITLE OF THE INVENTION

An assembly for securing a ferrule to a gear-box using a spring-loaded lock pin

DESCRIPTION OF THE INVENTION

Technical field of the invention

- 5 [0001] The present invention generally relates to an assembly for securing a gear-box using a spring-loaded lock pin. Further, the present invention particularly relates to a gear-box that is removably secured with a ferrule employing a ‘press and release’ mechanism.

Background of the invention

- 10 [0002] Gear-box lock mechanisms have evolved drastically over the past few years. Currently, turn-locks are employed for securing the gear-box with a ferrule which acts as a mating part between the gear-box and the turn-lock. The lock mechanism adapted by the current system requires the turn-lock to be manually rotated till the ferrule is firmly secured with the gear-box.
- 15 [0003] Due to continuous movement, there exists a possibility for the turn-lock to rotate in an anticlockwise direction till the ferrule is disengaged with the gear-box thereby causing the gear-box to unlock prematurely. Further, the current system adapts a primitive approach by demanding a manual confirmation for checking if the ferrule is firmly secured with the gear-box.
- 20 [0004] The Patent Application No. **US6729250B2** titled “*Coupling for a flexible rotatable drive shaft*” discloses a flexible rotatable drive shaft with a first male coupling that is received in a second female coupling located on a gearbox. The

male coupling has two circumferential grooves that define a first fully engaged position and a second intermediate engaged position. In both engaged positions the male coupler is mounted to the gearbox, however only in the fully engaged position is the flexible rotatable drive shaft in a driving relationship with the gearbox. The female coupler is provided with a latch pin for selectively engaging the first and second circumferential grooves. The latch pin is provided with a circumferential surface for engaging the grooves and latching the flexible rotatable drive shaft to the gearbox and a recessed section for unlatching the flexible rotatable drive shaft from the gearbox.

10 [0005] The Patent Application No. **US6715433B1** titled “*Restraint for a flexible drive shaft gearbox*” discloses a flexible rotatable drive shaft to drive a seed meter of a seeding machine. The seeding machine is provided with a seed meter gearbox. The seed meter gearbox has a flexible rotatable drive shaft receiving portion and a gear receiving portion. The gearbox output is drivingly coupled to the seed meter for driving the seed meter. The flexible rotatable drive shaft receiving portion extends outwardly from the gear receiving portion for receiving the drive ferrule of the flexible rotatable drive shaft. The gearbox restrain extends outwardly from the seeding machine and engages the flexible rotatable drive shaft receiving portion. The gearbox restrain comprises two legs that are parallel to the gearbox drive axis. The flexible rotatable drive shaft receiving portion is sandwiched between the two legs to prevent rotation of the gearbox.

[0006] Hence, there is a need for a simple and hassle-free mechanism for firmly lock or unlock a gear box by employing minimum number of components.

Summary of the invention:

25 [0007] The present invention overcomes the drawbacks of the prior art by providing an assembly for securing a gear-box using a spring-loaded lock pin. The assembly comprises a gear-box for enabling variable vehicle speed and torque, wherein the gear-box comprises an external keyway for facilitating anti-rotational movement under locked and unlocked condition of the gear-box. A ferrule is inserted into the gear box, wherein the ferrule comprises a circular recess for

securing the position of ferrule within the gear-box. The gear-box and the ferrule are removably secured using a spring-loaded lock pin. The spring-loaded lock pin enables lock and unlock of the ferrule by means of a 'press and release' mechanism .

5 [0008] The spring-loaded lock pin comprises an internal keyway, a slot recess and a projection. The internal keyway is etched in the spring-loaded lock pin for facilitating anti-rotational movement of the spring-loaded lock pin under locked and unlocked condition of the gear-box. The spring-loaded lock pin is removably
10 slid into the gear-box such that the external keyway in the gear-box mates with the internal keyway etched in the spring-loaded lock pin for facilitating anti-rotational movement of the spring-loaded lock pin under locked and unlocked condition of the ferrule and the gear-box. The slot recess is etched on one side of the spring-loaded lock pin for enabling hassle-free lock and unlock between the ferrule and the gear-box. Upon being pressed, the spring-loaded lock pin releases
15 the ferrule from the gear-box into the slot recess to enable free movement of the ferrule under unlocked condition.

[0009] Further, the assembly comprises a bellow and an o-ring disposed on opposite sides of the spring-loaded lock pin. The bellow protects the spring-loaded lock pin from external dust on the side in which it is disposed, and the o-
20 ring disposed on the side opposite to the bellow, protects the spring-loaded lock pin from external dust on the side in which it is disposed. Further, the assembly comprises a washer to enable proportional load distribution of the spring-loaded lock pin. The washer prevents the occurrence of damages to the o-ring caused due to the constant force exerted by the spring-loaded lock pin. The washer and a
25 circlip are employed for maintaining the position of the spring-loaded lock pin under locked condition of the gear-box and ferrule.

[0010] The present invention provides an assembly for securing a gear-box using a spring-loaded lock pin. The internal keyway etched in the spring-loaded lock pin facilitates anti-rotational movement of the spring-loaded lock pin under locked
30 and unlocked condition of the gear-box. Further, the 'press and release'

mechanism adapted by the present invention ensures a simple and secure engagement between the ferrule and the gear box.

Brief description of the drawings:

5 [0011] The foregoing and other features of embodiments will become more apparent from the following detailed description of embodiments when read in conjunction with the accompanying drawings. In the drawings, like reference numerals refer to like elements.

[0012] FIG 1 illustrates a front view of a gear-box with spring-loaded lock pin under disengaged condition of the gear box.

10 [0013] FIG 2 illustrates a front view of a gear-box with spring-loaded lock pin under engaged condition of the gear box.

[0014] FIG 3 illustrates an exploded view of the spring-loaded lock pin with an internal groove and slot to facilitate anti-rotational movement of the spring-loaded lock pin.

15 [0015] FIG 4 illustrates a side-view of the gear box with an external projection to facilitate anti-rotational movement of the spring-loaded lock pin.

[0016] FIG 5 illustrates a perspective view of the ferrule with a circular groove for securing the position of the ferrule within the gear-box.

Detailed description of the invention:

20 [0017] Reference will now be made in detail to the description of the present subject matter, one or more examples of which are shown in figures. Each example is provided to explain the subject matter and not a limitation. Various changes and modifications obvious to one skilled in the art to which the invention pertains are deemed to be within the spirit, scope and contemplation of the
25 invention.

[0018] The present invention provides an assembly for securing a gear-box using a spring-loaded lock pin wherein the gear-box is secured with a ferrule by means of a spring-loaded lock pin which enables lock and unlock of the ferrule through a 'press and release' mechanism. The spring-loaded lock pin comprises an internal keyway for facilitating anti-rotational movement of the spring-loaded lock pin and a slot recess for enabling hassle-free lock and unlock between the ferrule and the gear-box. Further, an external keyway provided in the gear-box mates with the internal keyway etched in the spring-loaded lock pin for facilitating anti-rotational movement of the spring-loaded lock pin under locked and unlocked condition of the ferrule.

[0019] FIG 1 illustrates an assembly for securing a gear-box using a spring-loaded lock pin. The assembly (100) comprises a gear-box (101) for enabling variable vehicle speed and torque, wherein the gear-box (101) comprises an external keyway (102) for facilitating anti-rotational movement under locked and unlocked condition of the gear-box (101). A ferrule (103) is inserted into the gear box (101), wherein the ferrule (103) comprises a circular recess (104) for securing the position of ferrule (103) within the gear-box (101). The gear-box (101) and the ferrule (103) are removably secured using a spring-loaded lock pin (105). The spring-loaded lock pin (105) enables lock and unlock of the ferrule (103) by means of a 'press and release' mechanism.

[0020] The spring-loaded lock pin (105) comprises an internal keyway (106), a slot recess (107) and a projection (108). The internal keyway (106) is etched in the spring-loaded lock pin (105) for facilitating anti-rotational movement of the spring-loaded lock pin (105) under locked and unlocked condition of the gear-box (101). The spring-loaded lock pin (105) is removably slid into the gear-box (101) such that the external keyway (102) of the gear-box (101) mates with the internal keyway (106) etched in the spring-loaded lock pin (105) for facilitating anti-rotational movement of the spring-loaded lock pin (105) under locked and unlocked condition of the ferrule (103) and the gear-box (101). The slot recess (107) is etched on one side of the spring-loaded lock pin (105) for enabling hassle-free lock and unlock between the ferrule (103) and the gear-box (101).

Upon being pressed, the spring-loaded lock pin (105) releases the ferrule (103) from the gear-box (101) into the slot (107) to enable free movement of the ferrule (103) under unlocked condition.

[0021] Further, the assembly (100) comprises a bellow (109) and an o-ring (110) which are disposed on opposite sides of the spring-loaded lock pin (105). The bellow (109) protects the spring-loaded lock pin (105) from external dust on the side in which it is disposed and the o-ring (110) disposed on the side opposite to the bellow (109), protects the spring-loaded lock pin (105) from external dust on the side in which it is disposed. Further, the assembly (100) comprises a washer (111) to enable proportional load distribution of the spring-loaded lock pin (105). The washer (111) prevents the occurrence of damages to the o-ring (110) caused due to the constant force exerted by the spring-loaded lock pin (105). The washer (111) and a circlip (112) are employed for maintaining the position of the spring-loaded lock pin (105) under locked condition of the gear-box (101) and ferrule (103).

[0022] FIG 2 illustrates a gear-box with spring-loaded lock pin under locked condition of the gear box. The slot recess (107) provided on the spring-loaded lock pin (105) enables hassle-free lock and unlock between the ferrule (103) and the gear-box (101). The projection (108) of the spring-loaded lock pin (105) indicates locked condition between the ferrule (103) and gear-box (101).

[0023] FIG 3 illustrates an exploded view of the spring-loaded lock pin with an internal keyway and slot recess to facilitate anti-rotational movement of the spring-loaded lock pin. The internal keyway (106) facilitates anti-rotational movement of the spring-loaded lock pin (105) under locked and unlocked condition of the gear-box (101). The slot recess (107) provided on the spring-loaded lock pin (105) enables hassle-free lock and unlock between the ferrule (103) and the gear-box (101).

[0024] FIG 4 illustrates a side-view of the gear box with an external keyway to facilitate anti-rotational movement of the spring-loaded lock pin. The gear-box (101) comprises an external keyway (102) for facilitating anti-rotational

movement under locked and unlocked condition of the gear-box (101). The external keyway (102) of the gear-box (101) mates with the internal keyway (106) etched in the spring-loaded lock pin (105) for facilitating anti-rotational movement of the spring-loaded lock pin (105) under locked and unlocked condition of the ferrule (103) and the gear-box (101).

[0025] FIG 5 illustrates a perspective view of the ferrule with a circular recess for securing the position of the ferrule within the gear-box. The circular recess (104) secures the position of ferrule (103) within the gear-box (101). Further, the assembly (100) enables a simple 'press and release' mechanism, wherein upon being pressed, the spring-loaded lock pin (105) releases the ferrule (103) from the gear-box (101) into the slot recess (107) to enable free movement of the ferrule (103) under unlocked condition. Therefore, the present invention provides a hassle-free mechanism for locking or unlocking a gear box by employing a minimum number of components.

[0026] The present invention provides an assembly for securing a gear-box (101) using a spring-loaded lock pin (105). The internal keyway (106) etched in the spring-loaded lock pin (105) facilitates anti-rotational movement of the spring-loaded lock pin (105) under locked and unlocked condition of the gear-box (101). Further, the 'press and release' mechanism adapted by the present invention ensures a simple and secure engagement between the ferrule (103) and gear box (101).

[0027] While at least one exemplary embodiment has been presented in the foregoing detailed description, it should be appreciated that a vast number of variations exist.

Reference numbers:

Components	Reference Numbers
Assembly	100
Gear-box	101
External keyway	102
Ferrule	103
Circular recess	104
Spring-loaded lock pin	105
Internal keyway	106
Slot recess	107
Projection	108
Bellow	109
O-ring	110
Washer	111
Circlip	112

5

10

Claims

We claim:

1. An assembly for securing a gear-box using a spring-loaded lock pin, the assembly (100) comprising:
 - 5 a. a gear-box (101) for enabling variable vehicle speed and torque, wherein the gear-box comprises an external keyway (102) for facilitating anti-rotational movement under locked and unlocked condition of the gear-box (101);
 - 10 b. a ferrule (103) inserted into the gear box (101), wherein the ferrule (103) comprises a circular recess (104) for securing the position of ferrule (103) within the gear-box (101);
 - c. a spring-loaded lock pin (105) for interfacing and securing the gear box (101) with the ferrule (103), wherein the spring-loaded lock pin (105) comprises:
 - 15 an internal keyway (106) etched in the spring-loaded lock pin (105) for facilitating anti-rotational movement of the spring-loaded lock pin (105) under locked and unlocked condition of the gear-box (101); and
 - 20 a slot recess (107) etched on one side of the spring-loaded lock pin (105) for enabling hassle-free lock and unlock between the ferrule (103) and the gear-box (101);
 - 25 a projection (108) of the spring-loaded lock pin (105) for indicating locked condition between the ferrule (103) and gear-box (101);
 - d. a bellows (109) disposed on one side of the spring-loaded lock pin (105), wherein the bellows (109) protects the spring-loaded lock pin (105) from external dust on the side in which it is disposed;
 - 30

- 5
- e. an o-ring (110) disposed on the side opposite to the bellow (109), wherein the o-ring (110) protects the spring-loaded lock pin (105) from external dust on the side in which it is disposed;
 - f. a washer (111) to enable proportional load distribution, wherein the washer (111) prevents the occurrence of damages to the o-ring (110) caused by the spring-loaded lock pin (105);
 - g. a circlip (112) for maintaining the position of the spring-loaded lock pin (105) under locked condition of the gear-box (101) and ferrule (103).
- 10
2. The assembly (100) as claimed in claim 1, wherein the spring-loaded lock pin (105) enables lock and unlock of the ferrule (103) by means of a 'press and release' mechanism.
- 15
3. The assembly (100) as claimed in claim 1, wherein the spring-loaded lock pin (105):
- a. secures the ferrule (103) with the gear-box (101) under locked condition;
- 20
- b. releases the ferrule (103) from the gear-box (101) into the slot recess (107) to enable free movement of the ferrule (103) under unlocked condition.
- 25
4. The assembly (100) as claimed in claim 1, wherein the spring-loaded lock pin (105) is removably slided into the gear-box (101) such that the external keyway (102) of the gear-box (101) mates with the internal keyway (106) etched in the spring-loaded lock pin (105) for facilitating anti-rotational movement of the spring-loaded lock pin (105) under locked and unlocked
- 30
- condition of the ferrule (103).

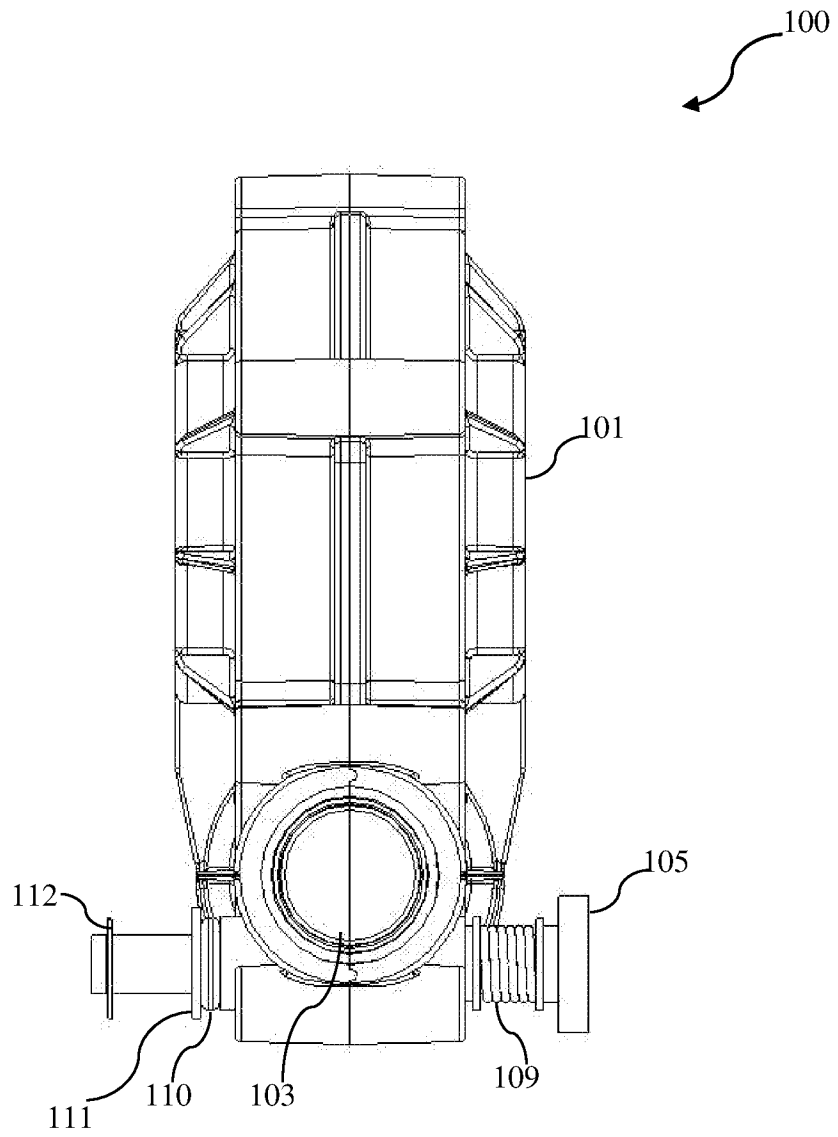

FIGURE 1

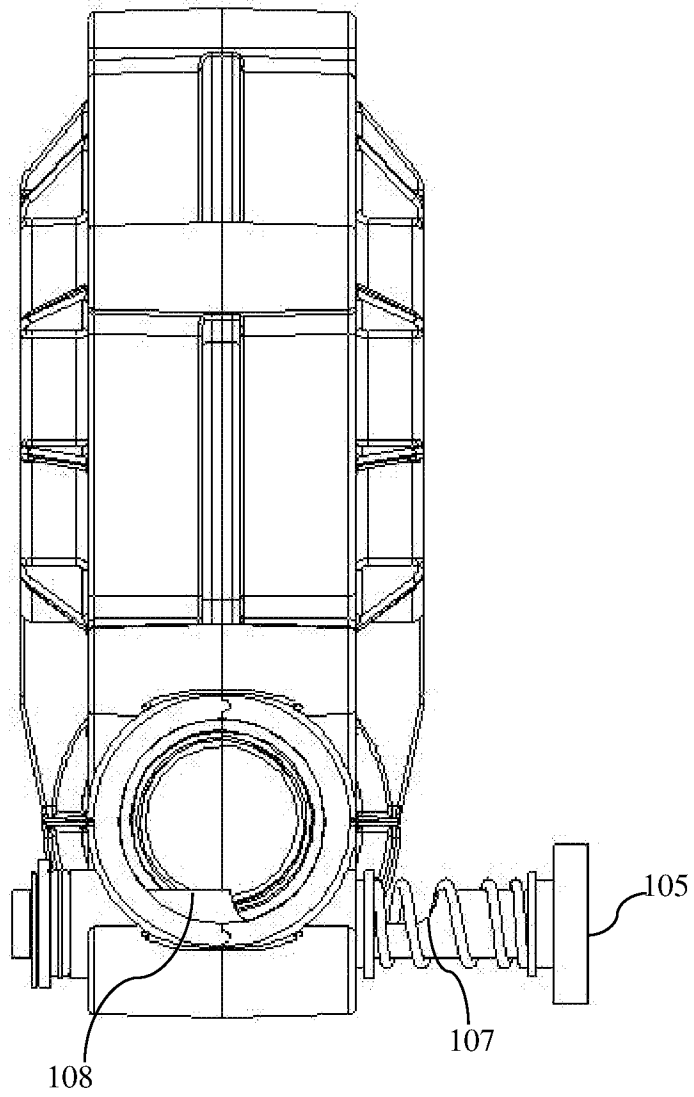

FIGURE 2

3/4

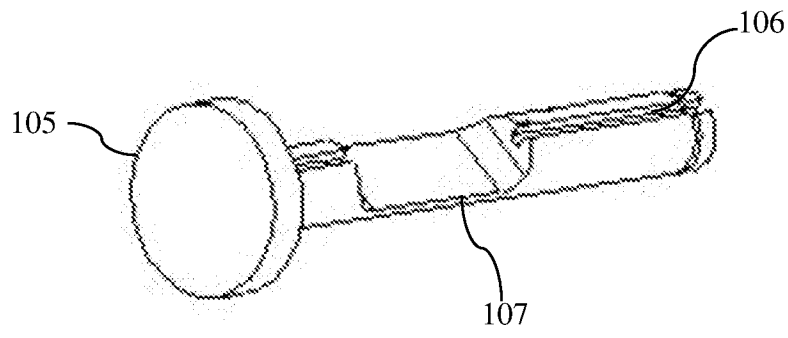

FIGURE 3

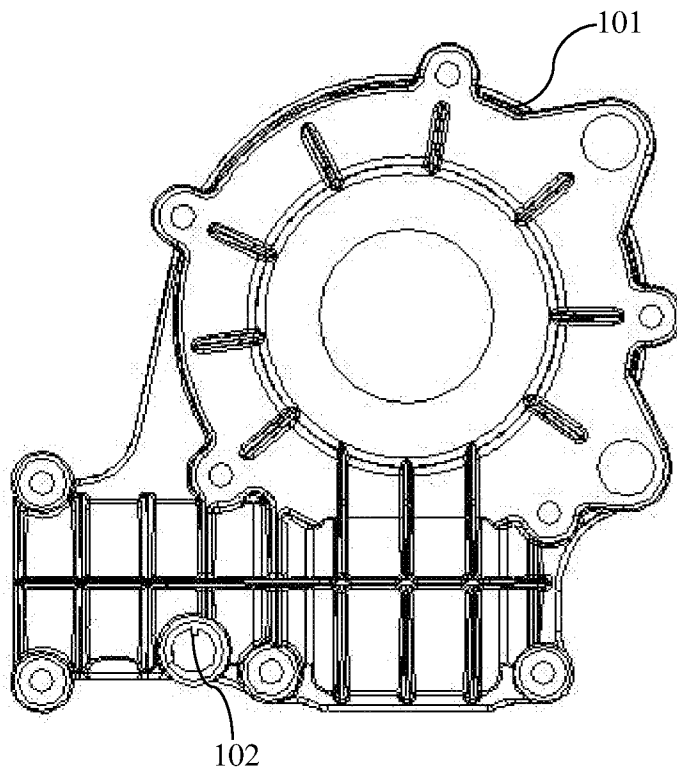

FIGURE 4

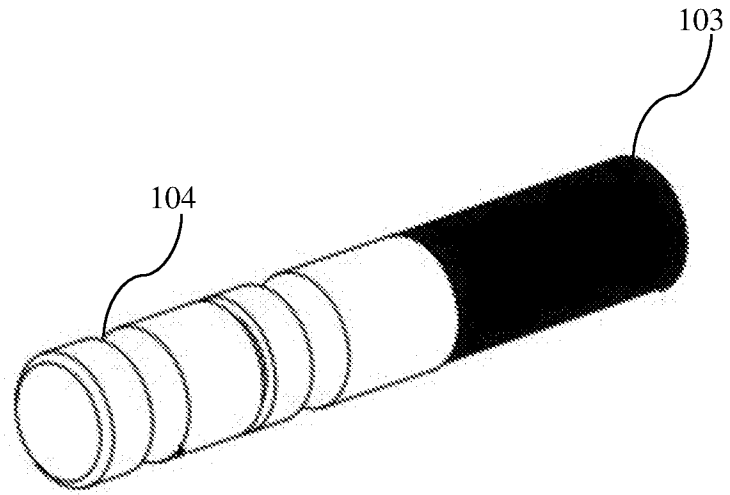

FIGURE 5

INTERNATIONAL SEARCH REPORT

International application No.
PCT/IB2020/053191

A. CLASSIFICATION OF SUBJECT MATTER E05C9/00,F16H63/34 Version=2020.01		
According to International Patent Classification (IPC) or to both national classification and IPC		
B. FIELDS SEARCHED		
Minimum documentation searched (classification system followed by classification symbols) E05C, F16H		
Documentation searched other than minimum documentation to the extent that such documents are included in the fields searched		
Electronic data base consulted during the international search (name of data base and, where practicable, search terms used) TotalPatent One, IPO Internal Database		
C. DOCUMENTS CONSIDERED TO BE RELEVANT		
Category*	Citation of document, with indication, where appropriate, of the relevant passages	Relevant to claim No.
Y	EP0940606B1 (Volkswagen AG; 07 May 2003) the entire document (as per English translation on Google Patents)	1-4
Y	US6729250B2 (Deere and Co et. al.; 04 May 2004) Abstract; column 2, line 10 - column 3, line 58; figures	1-4
<input type="checkbox"/> Further documents are listed in the continuation of Box C. <input checked="" type="checkbox"/> See patent family annex.		
* Special categories of cited documents: "A" document defining the general state of the art which is not considered to be of particular relevance "D" document cited by the applicant in the international application "E" earlier application or patent but published on or after the international filing date "L" document which may throw doubts on priority claim(s) or which is cited to establish the publication date of another citation or other special reason (as specified) "O" document referring to an oral disclosure, use, exhibition or other means "P" document published prior to the international filing date but later than the priority date claimed "T" later document published after the international filing date or priority date and not in conflict with the application but cited to understand the principle or theory underlying the invention "X" document of particular relevance; the claimed invention cannot be considered novel or cannot be considered to involve an inventive step when the document is taken alone "Y" document of particular relevance; the claimed invention cannot be considered to involve an inventive step when the document is combined with one or more other such documents, such combination being obvious to a person skilled in the art "&" document member of the same patent family		
Date of the actual completion of the international search 03-09-2020		Date of mailing of the international search report 03-09-2020
Name and mailing address of the ISA/ Indian Patent Office Plot No.32, Sector 14, Dwarka, New Delhi-110075 Facsimile No.		Authorized officer Krishan Kumar Telephone No. +91-1125300200

INTERNATIONAL SEARCH REPORT
Information on patent family members

International application No.
PCT/IB2020/053191

Citation	Pub.Date	Family	Pub.Date
EP 0940606 B1	07-05-2003	DE 19809424 A1	09-09-1991
		ES 2198795 T3	01-02-2004
US 6729250 B2	04-05-2004	EP 1388678 A1	11-02-2004
		ES 2265090 T3	01-02-2007
		CA 2435816 A1	08-02-2004
		BR 0302749 A	24-08-2004
		AR 040827 A1	20-04-2005