



(86) **Date de dépôt PCT/PCT Filing Date:** 2014/12/30
 (87) **Date publication PCT/PCT Publication Date:** 2015/07/09
 (85) **Entrée phase nationale/National Entry:** 2016/06/22
 (86) **N° demande PCT/PCT Application No.:** US 2014/072683
 (87) **N° publication PCT/PCT Publication No.:** 2015/103213
 (30) **Priorité/Priority:** 2013/12/30 (US61/921,847)

(51) **Cl.Int./Int.Cl. E21B 7/02** (2006.01),
E21B 10/42 (2006.01), **E21B 10/60** (2006.01)
 (71) **Demandeur/Applicant:**
 LONGYEAR TM, INC., US
 (72) **Inventeurs/Inventors:**
 PEARCE, CODY A., US;
 RUPP, MICHAEL D., US
 (74) **Agent:** BENNETT JONES LLP

(54) **Titre : TREPANS SANS GOUTTIERE OU A GOUTTIERE UNIQUE ET LEURS SYSTEMES ET PROCEDES D'UTILISATION**
 (54) **Title: NO-WATERWAY OR SINGLE WATERWAY DRILL BITS AND SYSTEMS AND METHODS FOR USING SAME**

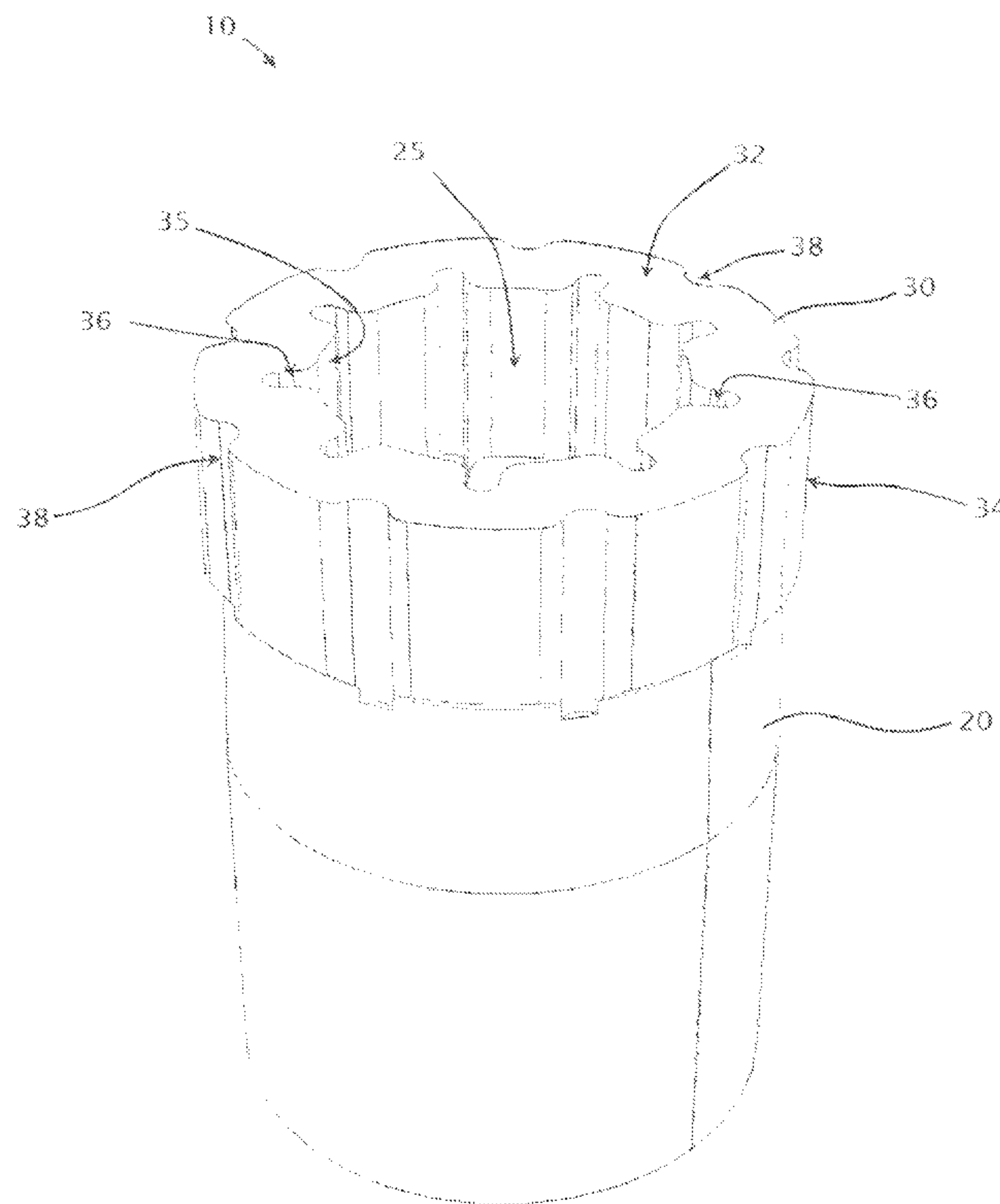

FIGURE 1A

(57) **Abrégé/Abstract:**

A drill bit for forming a hole in a formation. The drill bit has a shank and an annular crown that cooperate to define an interior space that receives water or other drilling fluid. The annular crown defines inner channels spaced circumferentially about an inner surface

(57) **Abrégé(suite)/Abstract(continued):**

of the crown and outer channels spaced circumferentially about an outer surface of the crown. The annular crown can completely circumferentially enclose the interior space of the drill bit, or the annular crown can be provided with a single waterway extending between the inner and outer surfaces of the crown.

(12) INTERNATIONAL APPLICATION PUBLISHED UNDER THE PATENT COOPERATION TREATY (PCT)

(19) World Intellectual Property
Organization
International Bureau(43) International Publication Date
9 July 2015 (09.07.2015)(10) International Publication Number
WO 2015/103213 A1

- (51) **International Patent Classification:**
E21B 7/02 (2006.01) E21B 10/60 (2006.01)
E21B 10/42 (2006.01)
- (21) **International Application Number:**
PCT/US2014/072683
- (22) **International Filing Date:**
30 December 2014 (30.12.2014)
- (25) **Filing Language:** English
- (26) **Publication Language:** English
- (30) **Priority Data:**
61/921,847 30 December 2013 (30.12.2013) US
- (71) **Applicant:** LONGYEAR TM, INC [US/US]; 10808 South River Front Parkway, Suite 400, South Jordan, UT 84095 (US).
- (72) **Inventors:** PEARCE, Cody, A.; 472 Waterford Way, Midvale, UT 84047 (US). RUPP, Michael, D.; 692 Justin Drive, Murray, UT 84123 (US).
- (74) **Agents:** DECARLO, Kean J. et al.; Ballard Spahr LLP, 999 Peachtree Street, Suite 1000, Atlanta, GA 30309 (US).
- (81) **Designated States** (*unless otherwise indicated, for every kind of national protection available*): AE, AG, AL, AM, AO, AT, AU, AZ, BA, BB, BG, BH, BN, BR, BW, BY, BZ, CA, CH, CL, CN, CO, CR, CU, CZ, DE, DK, DM, DO, DZ, EC, EE, EG, ES, FI, GB, GD, GE, GH, GM, GT, HN, HR, HU, ID, IL, IN, IR, IS, JP, KE, KG, KN, KP, KR, KZ, LA, LC, LK, LR, LS, LU, LY, MA, MD, ME, MG, MK, MN, MW, MX, MY, MZ, NA, NG, NI, NO, NZ, OM, PA, PE, PG, PH, PL, PT, QA, RO, RS, RU, RW, SA, SC, SD, SE, SG, SK, SL, SM, ST, SV, SY, TH, TJ, TM, TN, TR, TT, TZ, UA, UG, US, UZ, VC, VN, ZA, ZM, ZW.
- (84) **Designated States** (*unless otherwise indicated, for every kind of regional protection available*): ARIPO (BW, GH, GM, KE, LR, LS, MW, MZ, NA, RW, SD, SL, ST, SZ, TZ, UG, ZM, ZW), Eurasian (AM, AZ, BY, KG, KZ, RU, TJ, TM), European (AL, AT, BE, BG, CH, CY, CZ, DE, DK, EE, ES, FI, FR, GB, GR, HR, HU, IE, IS, IT, LT, LU, LV, MC, MK, MT, NL, NO, PL, PT, RO, RS, SE, SI, SK,

[Continued on next page]

(54) **Title:** NO-WATERWAY OR SINGLE WATERWAY DRILL BITS AND SYSTEMS AND METHODS FOR USING SAME

FIGURE 1A

(57) **Abstract:** A drill bit for forming a hole in a formation. The drill bit has a shank and an annular crown that cooperate to define an interior space that receives water or other drilling fluid. The annular crown defines inner channels spaced circumferentially about an inner surface of the crown and outer channels spaced circumferentially about an outer surface of the crown. The annular crown can completely circumferentially enclose the interior space of the drill bit, or the annular crown can be provided with a single waterway extending between the inner and outer surfaces of the crown.

WO 2015/103213 A1 

SM, TR), OAPI (BF, BJ, CF, CG, CI, CM, GA, GN, GQ, GW, KM, ML, MR, NE, SN, TD, TG). **Published:**

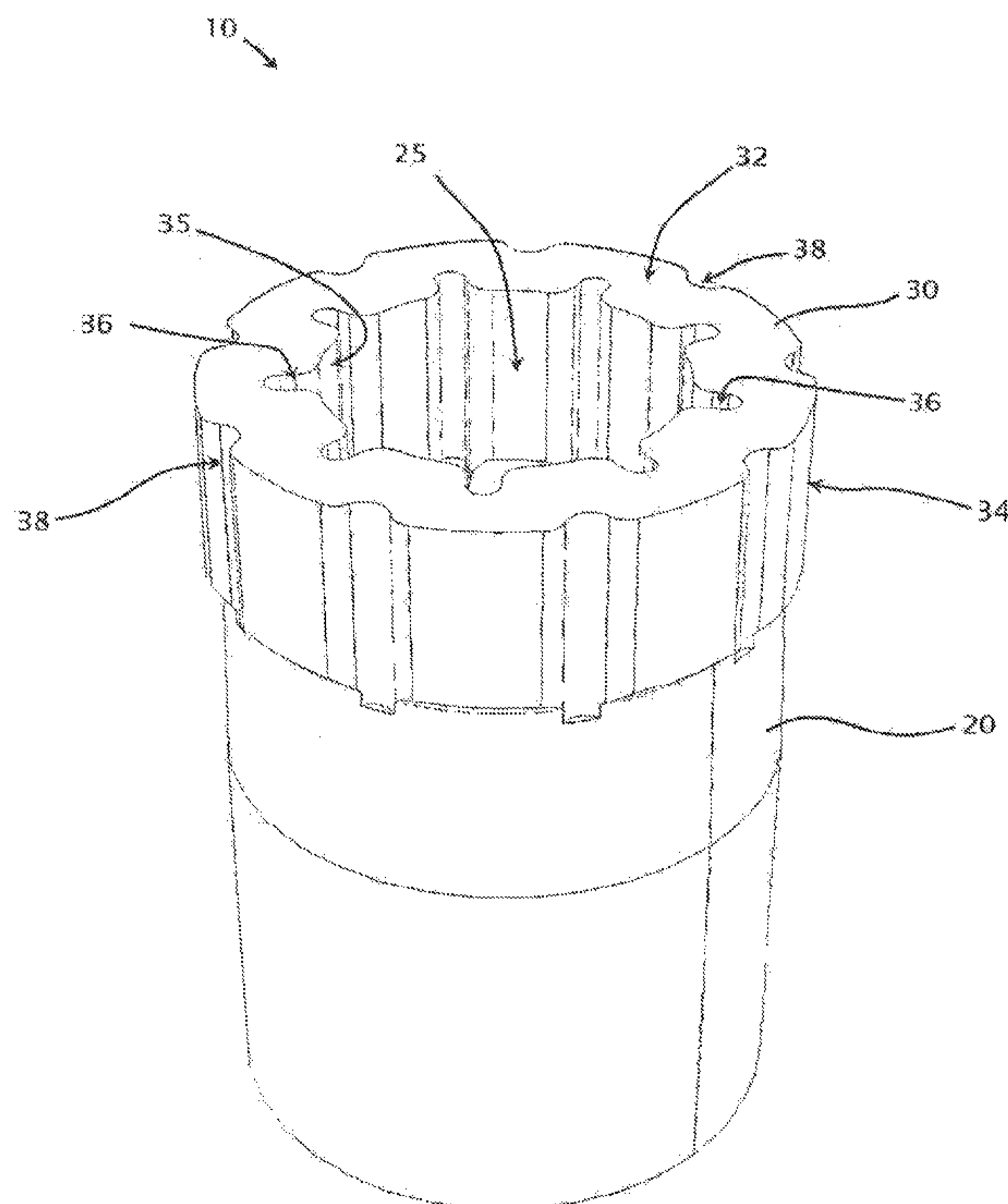
— *with international search report (Art. 21(3))*

Declarations under Rule 4.17:

— *as to applicant's entitlement to apply for and be granted a patent (Rule 4.17(ii))*

**NO-WATERWAY OR SINGLE WATERWAY DRILL BITS AND
SYSTEMS AND METHODS FOR USING SAME**

CROSS-REFERENCE TO RELATED PATENT APPLICATION

[0001] This application claims priority to U.S. Provisional Patent Application No. 61/921,847, filed December 30, 2013, which is incorporated by reference herein in its entirety.

FIELD

[0002] This invention relates to drill bits for forming a hole in a formation, and, more particularly, to annular drill bits for forming a hole in a formation.

BACKGROUND

[0003] Existing drill bits typically have a central waterway and a series of channels or slots that provide fluid communication between a side surface of the bit and the central waterway. These channels and/or slots decrease the efficiency of cooling and flushing at the bit face. The channels and/or slots also limit the height of the crown of the bit - if a crown with the channels and/or slots is made too tall, the crown will fail during drilling. Thus, the presence of the channels and/or slots effectively decreases the lifespan of existing drill bits, thereby increasing the cost of drill bit production.

[0004] Many drilling areas, such as South America and Australia, have limited water supplies. In these areas, it can be challenging to perform drilling operations using conventional drill bits, which require large amounts of water. Even in areas with larger water supplies, water trucks are required to haul water to the drill site, thereby increasing the cost of drilling operations.

[0005] Thus, there is a need in the pertinent art for stronger drill bits that improve flushing and cooling, as compared to existing drill bits. There is a further need in the pertinent art for drill bits that require less water (or other drilling fluid) than conventional drill bits, thereby decreasing the cost of drilling operations.

SUMMARY

[0006] Described herein is a drill bit for forming a hole in a formation. The drill bit has a longitudinal axis, a shank, and an annular crown. The annular crown has a cutting face, an inner

surface, and an outer surface. The annular crown and the shank cooperate to define an interior space about the longitudinal axis. The interior space can be configured to receive water or other drilling fluid during use of the drill bit.

[0007] In one aspect, the annular crown can define a plurality of inner channels spaced circumferentially about the inner surface of the annular crown and extending radially outwardly away from the longitudinal axis. The annular crown can also define a plurality of outer channels spaced circumferentially about the outer surface of the annular crown and extend radially inwardly toward the longitudinal axis. The annular crown can completely circumferentially enclose the interior space. In exemplary aspects, the annular crown does not have waterways extending radially between the outer surface of the annular crown and the interior space. Systems for forming a hole in a formation using the drill bit are also described.

[0008] Additional advantages of the invention will be set forth in part in the description which follows, and in part will be obvious from the description, or may be learned by practice of the invention. The advantages of the invention will be realized and attained by means of the elements and combinations particularly pointed out in the appended claims. It is to be understood that both the foregoing general description and the following detailed description are exemplary and explanatory only and are not restrictive of the invention, as claimed.

DETAILED DESCRIPTION OF THE FIGURES

[0009] These and other features of the preferred embodiments of the invention will become more apparent in the detailed description in which reference is made to the appended drawings wherein:

[0010] Figure 1A is a perspective view of an exemplary drill bit having no waterways or notches, as disclosed herein. Figure 1B is a top view of the drill bit of Figure 1A.

[0011] Figure 2A is a perspective view of an exemplary drill bit having a single waterway as disclosed herein. Figure 2B is a top view of the drill bit of Figure 2A.

[0012] Figure 3 is a perspective view of an exemplary drill bit having a single waterway as disclosed herein.

[0013] Figure 4 is a perspective view of an exemplary drill bit having a single waterway as disclosed herein, showing a raised central portion of the crown of the drill bit with respective

inner and outer portions that respectively adjoin the inner and outer surfaces being lowered relative to the raised central portion .

[0014] Figure 5 is a perspective view of an exemplary drill bit having a single waterway as disclosed herein, showing a lowered central portion of the crown of the drill bit with respective inner and outer portions that respectively adjoin the inner and outer surfaces being raised relative to the lowered central portion.

[0015] Figure 6 depicts an exemplary drill bit having no waterways or notches, as disclosed herein, before and after use of the drill bit in drilling operations.

[0016] Figure 7 is a perspective view of any exemplary drill bit having a single outer channel, a single inner channel, and a single waterway as disclosed herein.

[0017] Figure 8 is a perspective view of the drill bit of Figure 7.

[0018] Figure 9 depicts an exemplary drilling system comprising a drill bit as disclosed herein.

DETAILED DESCRIPTION

[0019] The present invention can be understood more readily by reference to the following detailed description, examples, drawings, and claims, and their previous and following description. However, before the present devices, systems, and/or methods are disclosed and described, it is to be understood that this invention is not limited to the specific devices, systems, and/or methods disclosed unless otherwise specified, as such can, of course, vary. It is also to be understood that the terminology used herein is for the purpose of describing particular aspects only and is not intended to be limiting.

[0020] The following description of the invention is provided as an enabling teaching of the invention in its best, currently known embodiment. To this end, those skilled in the relevant art will recognize and appreciate that many changes can be made to the various aspects of the invention described herein, while still obtaining the beneficial results of the present invention. It will also be apparent that some of the desired benefits of the present invention can be obtained by selecting some of the features of the present invention without utilizing other features. Accordingly, those who work in the art will recognize that many modifications and adaptations to the present invention are possible and can even be desirable in certain circumstances and are a

part of the present invention. Thus, the following description is provided as illustrative of the principles of the present invention and not in limitation thereof.

[0021] As used throughout, the singular forms “a,” “an” and “the” include plural referents unless the context clearly dictates otherwise. Thus, for example, reference to “a channel” can include two or more such channels unless the context indicates otherwise.

[0022] Ranges can be expressed herein as from “about” one particular value, and/or to “about” another particular value. When such a range is expressed, another aspect includes from the one particular value and/or to the other particular value. Similarly, when values are expressed as approximations, by use of the antecedent “about,” it will be understood that the particular value forms another aspect. It will be further understood that the endpoints of each of the ranges are significant both in relation to the other endpoint, and independently of the other endpoint.

[0023] As used herein, the terms “optional” or “optionally” mean that the subsequently described event or circumstance may or may not occur, and that the description includes instances where said event or circumstance occurs and instances where it does not.

[0024] The word “or” as used herein means any one member of a particular list and also includes any combination of members of that list.

[0025] Described herein with reference to Figures 1A-3 is a drill bit 10 for forming a hole in a formation. The drill bit 10 has a longitudinal axis LA. In exemplary aspects, the drill bit 10 can comprise a shank 20 and an annular crown 30. It is contemplated that the drill bits disclosed herein can increase the strength of the drill bit compared to conventional drill bits. It is further contemplated that the increased strength of the drill bits can permit manufacturing of taller drill bits than are conventionally manufactured, thereby increasing the lifespan of the drill bits. This, in turn, can greatly decrease the costs associated with the production of drill bits (compared to conventional drill bit production). It is still further contemplated that the drill bits disclosed herein can provide improved flushing and cooling relative to conventional drill bits, which comprise slots or windows extending between an outer surface of the drill bit and a central waterway (interior space) of the drill bit. Thus, it is contemplated that the drill bits disclosed herein can operate more efficiently than conventional drill bits.

[0026] More particularly, it is contemplated that, during operation of the drill bits disclosed herein, substantially all of the water (or other drilling fluid) can contact the face of the drill bit. It is further contemplated that the wearing of diamonds in conventional drill bits is due to the high friction and heat caused by the rock of a formation. It is further contemplated that the faster the rock cuttings are flushed from the face of the drill bit to the outer diameter of the drill bit, the less regrinding and/or re-cutting of the formation will be encountered, thereby increasing the production and cutting life of the drill bit. It is still further contemplated that this improvement in flushing and cooling can reduce the abrading of matrix which can increase the diamond exposure by increasing the matrix tail that supports diamonds on the bit face. It is still further contemplated that this can create a larger displacement of formation by the exposed diamond and the creation of more secondary fracturing of the formation being drilled, thereby leading to increased drilling performance.

[0027] It is further contemplated that the drill bits disclosed herein can be easier to manufacture than conventional drill bits. It is contemplated that the methods of manufacturing the drill bits disclosed herein can employ reduced amounts of cold pressing cycles, placing of face waterways and/or windows, and/or hand-setting face waterways and/or windows.

[0028] It is still further contemplated that the efficiency of flushing and cooling provided by the drill bits disclosed herein can reduce the amount of water required for drilling operations. In exemplary aspects, it is contemplated that the drill bits disclosed herein can be ideally suited for usage in areas with limited water supplies, such as South America and Australia.

[0029] In one aspect, the annular crown 30 can have a cutting face 32 that adjoins an outer circumferential surface 34 and an inner circumferential surface 35. It is contemplated that the annular crown 30 and the shank 20 can cooperate to define an interior space 25 about the longitudinal axis LA. It is further contemplated that the interior space 25 can be configured to receive water or other drilling fluid during use of the drill bit 10. In one aspect, the water or other drilling fluid can be supplied to the interior space 25 at a desired pressure.

[0030] In still another aspect, the annular crown 30 can completely circumferentially enclose the interior space 25. Optionally, in exemplary aspects, as shown in Figures 1 and 3, the annular crown 30 does not comprise a waterway extending radially between the outer surface 34 of the annular crown and the inner surface 35 (and the interior space 25).

[0031] However, in other optional aspects (discussed further below), it is contemplated that the annular crown 30 can comprise a single waterway extending from an inner surface of the annular crown to the outer surface of the annular crown, thereby providing communication between the exterior of the drill bit and the interior space 25. In these aspects, it is contemplated that the single waterway can optionally be a notch extending from the cutting face of the annular crown toward the shank along at least a portion of the axial length of the annular crown. Optionally, it is contemplated that the notch can extend along the entire axial length of the annular crown until it reaches the shank. When the annular crown 30 comprises a single waterway, it is contemplated that the single waterway can buffer the pressure spike experienced at the cutting face and decrease the maximum pressure required at the cutting face. It is further contemplated that the single waterway can be selectively sized depending upon the pressure and/or velocity required for a particular drilling application. In use, it is contemplated that drill bits having a single waterway (*e.g.*, a single notch) as disclosed herein can be easier to control in operation than conventional drill bits having a plurality of waterways. It is further contemplated that the use of a single waterway (*e.g.*, a single notch) can ensure that the drill bit is stronger than conventional bits, which have a plurality of waterways. In particular, it is contemplated that by using only a single waterway, the possibility of lever action, which typically occurs at the location of a waterway, is significantly reduced. Whereas conventional drill bits use a plurality of waterways that are balanced relative to a center point of the drill bit, it is further contemplated that the use of a single waterway yields unexpected beneficial results as disclosed herein. It is still further contemplated that the single waterway disclosed herein can function as a pressure release mechanism and can have little or no impact on the cooling of the drill bit or the fluid flow proximate the drill bit. This is contrary to conventional drill bits, which use a plurality of waterways to cool the drill bit and promote more efficient fluid flow proximate the drill bit.

[0032] In an additional aspect, the inner surface of the annular crown 30 can define at least one inner channel 36 extending radially outwardly away from the longitudinal axis LA. In exemplary aspects, it is contemplated that the at least one inner channel 36 can comprise a plurality of inner channels 36 spaced circumferentially about the inner surface of the annular crown and extending radially outwardly away from the longitudinal axis LA. Optionally, in some exemplary aspects, the plurality of inner channels 36 can be substantially equally circumferentially spaced about the inner surface of the annular crown 30. In one aspect, it is

contemplated that the plurality of inner channels 36 can optionally be substantially equally sized. In other aspects, it is contemplated that at least one of the inner channels can have a different size than at least one other inner channel. As used herein, the “size” of an inner channel 36 generally refers to the two-dimensional area of the channel, as measured within a plane that is substantially perpendicular to the longitudinal axis of the drill bit 10.

[0033] In another aspect, it is contemplated that, in cross-section to the longitudinal axis LA, the area of the surface of the plurality of the inner channels 36 to the percentage of the area of the inner circumferential surface 35 can range between about 10% to about 80%. Optionally, the area of the surface of the plurality of the inner channels 36 to the percentage of the area of the inner circumferential surface 35 can range between about 25% to about 65%, between about 45% to about 60%, or about 55%..

[0034] In a further aspect, the outer surface of the annular crown 30 can define at least one outer channel 38 extending radially inwardly toward the longitudinal axis LA. In exemplary aspects, it is contemplated that the at least one outer channel 38 can comprise a plurality of outer channels 38 spaced circumferentially about the outer surface of the annular crown and extending radially inwardly toward the longitudinal axis LA. In other exemplary aspects, it is contemplated that the annular crown 30 can have an outer diameter that is greater than an outer diameter of the shank 20 such that the annular crown projects radially outwardly relative to the shank. Optionally, in some exemplary aspects, the plurality of outer channels 38 can be substantially equally circumferentially spaced about the outer surface 34 of the annular crown 30. In one aspect, it is contemplated that the plurality of outer channels 38 can optionally be substantially equally sized. In other aspects, it is contemplated that at least one of the outer channels can have a different size than at least one other outer channel. As used herein, the “size” of an outer channel 38 generally refers to the two-dimensional area of the channel, as measured within a plane that is substantially perpendicular to the longitudinal axis of the drill bit 10.

[0035] In one aspect, the annular crown can have a radial thickness between the inner surface and the outer surface that corresponds to difference between the outer diameter and the inner diameter of the annular crown. In this aspect, it is contemplated that each inner channel of the plurality of inner channels can have a radial dimension (substantially corresponding to a radial depth relative to the inner surface) that is less than the radial thickness of the annular

crown. It is further contemplated that each outer channel of the plurality of outer channels can have a radial dimension (substantially corresponding to a radial depth relative to the outer surface) that is less than the radial thickness of the annular crown. In exemplary aspects, it is contemplated that the ratio between the radial thickness of the annular crown and the radial dimension of the plurality of inner channels can range from about 1.25:1 to about 15:1 and, more preferably, can range from about 1.5:1 to about 3.5:1. In exemplary aspects, it is contemplated that the ratio between the radial thickness of the annular crown and the radial dimension of the plurality of outer channels can range from about 1:25:1 to about 15:1 and, more preferably, can range from about 1.5:1 to about 3.5:1. In additional exemplary aspects, it is contemplated that the radial dimension of the plurality of inner channels can be greater than the radial dimension of the plurality of outer channels. In various exemplary, non-limiting aspects, it is contemplated that the radial dimension of inner and outer channels can range from about 0.050 inches to about 0.30 inches and, more preferably, from about 0.090 inches to about 0.250 inches.

[0036] In one aspect, the number of inner channels can be the same as the number of outer channels. In another aspect, it is contemplated that the number of inner channels can be greater than the number of outer channels. In a further aspect, it is contemplated that the number of inner channels can be less than the number of outer channels.

[0037] In exemplary aspects, it is contemplated that an inner diameter of the annular crown, which generally corresponds to the distance of a line extending from a first point on the inner surface of the crown to an opposed second point on the inner surface of the crown, with the line passing through a center point of the crown that coincides with the longitudinal axis LA, can range from about 0.9 inches to about 8 inches. For crowns having a substantially circular cross-section, this inner diameter can correspond to an inner circumference ranging from about 2.8 inches to about 25.1 inches. In these aspects, it is contemplated that an inner channel can be provided for every 1 to 2.5 inches along the inner circumference. However, it is contemplated that annular crowns having larger or smaller inner diameters and inner circumferences can be used. In some exemplary aspects, it is contemplated that the number of inner channels can range from 3 to 16 inner channels. However, it is contemplated that some exemplary annular crowns can have up to about 40 inner channels. In some exemplary aspects, it is contemplated that the inner diameter of the annular crown can vary about the inner surface. In additional exemplary aspects, it is contemplated that the annular crown can have a non-circular profile, such as, for

example and without limitation, an elliptical profile. In these aspects, it is contemplated that the inner circumference of the annular crown can correspond to the total arcuate dimension defined by the inner surface of the annular crown as it extends completely around the longitudinal axis LA of the crown.

[0038] Optionally, as shown in Figures 1A-3, it is contemplated that each outer channel of the plurality of outer channels can be positioned circumferentially between sequential inner channels of the plurality of inner channels. It is further contemplated that the annular crown can optionally have a substantially serpentine radial profile. In exemplary optional aspects, it is contemplated that each outer channel can be substantially aligned with a respective inner channel along a line extending through the longitudinal axis LA across the diameter of the annular crown (perpendicular to the longitudinal axis LA). In these aspects, it is further contemplated that each inner channel can be substantially aligned with a respective outer channel along a line extending through the longitudinal axis LA across the diameter of the annular crown (perpendicular to the longitudinal axis LA).

[0039] In one optional exemplary aspect, as shown in Figure 4, it is contemplated that at least one outer channel can substantially overlap with at least one inner channel such that a line extending radially from the longitudinal axis LA passes through both an inner channel and an outer channel. In this aspect, it is contemplated that the at least one outer channel of the crown can optionally comprise a single outer channel. It is further contemplated that the at least one inner channel of the crown can optionally comprise a single inner channel.

[0040] In additional aspects, each channel 36, 38 of the plurality of inner channels and the plurality of outer channels can have a width. Optionally, in these aspects, it is contemplated that each channel 36, 38 of the plurality of inner channels and the plurality of outer channels can have a variable width. For example, the width of each outer channel 38 can optionally decrease from the outer surface of the full face crown moving radially inwardly toward the longitudinal axis. Thus, it is contemplated that each channel 38 of the plurality of channels can be inwardly tapered moving toward the longitudinal axis LA. In another exemplary aspect, it is contemplated that the inner and outer channels can be substantially U-shaped channels.

[0041] In exemplary aspects, it is contemplated that the annular crown 30 can have a plurality of circumferentially spaced outer portions 40 that define the outer surface (and outer

diameter) of the annular crown. In these aspects, it is contemplated that a respective outer channel 38 can be positioned between adjacent outer portions 40 of the plurality of outer portions. In other exemplary aspects, it is contemplated that the annular crown 30 can have a plurality of circumferentially spaced inner portions 42 that define the inner surface (and inner diameter) of the annular crown. In these aspects, it is contemplated that a respective inner channel 36 can be positioned between adjacent inner portions 42 of the plurality of inner portions.

[0042] Optionally, in some exemplary aspects, it is contemplated that an outer surface of the shank 20 can define at least one flute (or groove) extending substantially parallel to the longitudinal axis LA of the bit 10. In these aspects, each flute of the at least one flute of the outer surface of the shank can optionally correspond to a rounded groove extending radially from the outer surface of the shank 20 toward an inner surface of the shank. As shown in Figure 3, it is contemplated that each flute of the at least one flute of the outer surface of the shank 20 can optionally be positioned in fluid communication with a respective outer channel 38 of the annular crown 30.

[0043] Optionally, in further exemplary aspects, it is contemplated that the inner surface of the shank 20 can define at least one flute (or groove) extending substantially parallel to the longitudinal axis LA of the bit 10. In these aspects, each flute of the at least one flute of the inner surface of the shank can optionally correspond to a rounded groove extending radially from the inner surface of the shank 20 toward an outer surface of the shank. It is contemplated that each flute of the at least one flute of the inner surface of the shank 20 can optionally be positioned in fluid communication with a respective inner channel 36 of the annular crown 30.

[0044] As further described above, in some optional aspects, and as shown in Figures 2A-2B and 4, it is contemplated that the annular crown 30 can comprise a single waterway extending from an inner surface of the annular crown to the outer surface of the annular crown. In these aspects, it is contemplated that the single waterway can be configured to increase the velocity of drilling fluid at the waterway entrance, and thereby, provide improved flushing of cuttings.

[0045] In exemplary aspects, it is contemplated that the single waterway can be an axially-tapered waterway (tapered relative to the longitudinal axis of the drill bit). In these aspects, it is contemplated that the axially-tapered waterway can ensure that the opening of the waterway in

the inner surface of the drill bit can be smaller than the opening of the waterway in the outer surface of the drill bit. Thus, the waterway can act like a nozzle by increasing the velocity of the drilling fluid at the waterway entrance in the inner surface of the drill bit. The capability of the axially-tapered waterway to increase the velocity of the drilling fluid at the waterway entrance can provide increased flushing of cuttings, and can help prevent clogging of the waterway. Furthermore, it is contemplated that the axially-tapered waterway can provide improved flow of drilling fluid without significantly sacrificing bit body volume at the inside diameter or reducing the cutting surface of the bit face. Thus, it is contemplated that the axially-tapered waterway can provide for increased drilling performance and increased drilling life.

[0046] In some aspects, it is contemplated that the single waterway can be an axially- and radially-tapered waterway, or in other words, a double-tapered waterway. It is contemplated that such a double-tapered waterway can help ensure that the waterway increases in dimension in each axis as it extends from the inner surface of the drill bit to the outer surface of the drill bit. It is contemplated that the increasing size of the double-tapered waterway can reduce the likelihood of debris lodging within the waterway, and thus, increase the drilling performance of the drill bit. It is further contemplated that the double-tapered waterway can allow for a smaller waterway opening at the inside diameter, while still allowing for a large waterway opening at the outside diameter of the drill bit. It is contemplated that this configuration can allow for an increase in the amount of matrix material at the inside diameter, and thus, help increase the life of the drill bit while also providing effective flushing. It is further contemplated that the increased life of such a drill bit can reduce drilling costs by reducing the need to trip a drill string from the bore hole to replace a prematurely worn drill bit.

[0047] As shown in Figures 2A-2B, the single waterway can be a notch 112 defined by at least three surfaces 112a, 112b, 112c. In particular, the notch 112 can be defined by a first side surface 112a, an opposing side surface 112b, and a top surface 112c. Optionally, it is contemplated that each of the sides surfaces 112a, 112b can extend from the inner surface of the crown to the outer surface of the crown in a direction generally normal to the inner surface of the crown. Thus, it is contemplated that the width of the notch 112 at the outer surface of the crown can be approximately equal to the width of the notch 112 at the inner surface of the crown. In other words, the circumferential distance between the first side surface 112a and the second side surface 112b of the notch 112 at the outer surface can be approximately equal to the

circumferential distance between the first side surface 112a and the second side surface 112b of the notch 112 at the inner surface. Alternatively, in other optional aspects, and as explained in greater detail below, it is contemplated that one or more of the side surfaces 112a, 112b can have a radial and/or a circumferential taper.

[0048] It is contemplated that the notch 112 can have any shape that allows it to operate as intended. In particular, it is contemplated that the shape and configuration of the notch 112 can be altered depending upon the characteristics desired for the drill bit and/or the characteristics of the formation to be drilled. For example, it is contemplated that the notch can optionally have a rectangular shape when viewed from cutting face. Alternatively, in other optional aspects, it is contemplated that the notch can have a square, triangular, circular, trapezoidal, polygonal, or elliptical shape or any combination thereof.

[0049] It is further contemplated that the notch 112 can have any width or length that allows it to operate as intended. In exemplary aspects, it is contemplated that the notch 112 can have a length (i.e., distance from the inner surface to the outer surface) that is greater than its width (i.e., distance between opposing side surfaces 112a and 112b). In alternative implementations of the present invention, however, the notch 112 can have a width greater than its length, or a width that is approximately equal to its length.

[0050] As mentioned previously, the waterway (i.e., notch 112) can be axially tapered. In exemplary aspects, the top surface 112c of the notch 112 can taper from the inner surface to the outer surface in a direction generally from the cutting face toward the shank. In other words, it is contemplated that the height or longitudinal dimension of the notch 112 can increase as the notch 112 extends from the inner surface to the outer surface of the crown. Thus, in some exemplary aspects, the longitudinal dimension of the notch 112 at the outer surface can be greater than the longitudinal dimension of the notch 112 at the inner surface. In other words, the notch 112 can extend into the cutting face a first distance at the inner surface and extend into the cutting face a second distance at the outer surface, where the second distance is greater than the first distance.

[0051] It is contemplated that the axial-taper of the notch 112 can help ensure that the opening of the notch 112 at the inner surface is smaller than the opening of the notch 112 at the outer surface of the crown. It is further contemplated that this difference in opening sizes can increase the velocity of drilling fluid at the inner surface as it passes to the outer surface of the

crown. Thus, as explained above, the axial-taper of the notch 112 can provide for more efficient flushing of cuttings and cooling of the cutting face. Furthermore, it is contemplated that the increasing size of the notch can also help ensure that debris does not jam or clog in the notch 112 as drilling fluid forces it from the inner surface to the outer surface.

[0052] Additionally, it is contemplated that the axial-taper of the notch 112 can provide the notch 112 with increasing size without reducing the size of the cutting face. It is further contemplated that an increased surface area of the cutting face can provide for more efficient drilling. Furthermore, it is contemplated that the axial-taper of the notch can provide for increased flushing and cooling, while also not decreasing the volume of crown material at the inner surface. It is still further contemplated that the increased volume of crown material at the inner surface can help increase the drilling life of the drill bit.

[0053] Optionally, in exemplary aspects, it is contemplated that the crown can define at least one inner flute positioned in fluid communication with the notch 112. In these aspects, it is contemplated that the at least one inner flute can extend from the shank axially along the inner surface of the crown to the notch 112. It is further contemplated that the at least one inner flute can help direct drilling fluid to the notch 112. In another optional aspect, it is contemplated that the at least one inner flute can extend from the shank to the cutting face, or even along the shank.

[0054] Optionally, in other exemplary aspects, it is contemplated that the drill bit can comprise at least one outer flute. In these aspects, it is contemplated that the at least one outer flute can extend radially from the outer surface toward the inner surface of the crown. It is contemplated that the at least one outer flute can help direct drilling fluid along the outer surface of the drill bit from the notch toward the shank. Optionally, it is contemplated that the at least one outer flute can extend from the notch 112 axially along the outer surface to the shank. In another optional aspect, it is contemplated that the at least one outer flute can extend from the cutting face to the shank, or even along the shank.

[0055] As mentioned previously, in exemplary aspects, the single waterway 112 can be a double-tapered waterway. In these aspects, the notch 112 can have a radial taper in addition to an axial taper. In some aspects, the second side surface 112b of the notch 112 can taper from the inner surface to the outer surface in a direction generally clockwise around the circumference of the cutting face. As used herein, the terms "clockwise" and "counterclockwise" refer to

directions relative to the longitudinal axis of a drill bit when viewing the cutting face of the drill bit. Thus, the width of the notch 112 can increase as the notch 112 extends from the inner surface to the outer surface of the crown. Thus, in some aspects, the width of the notch 112 at the outer surface can be greater than the width of the notch 112 at the inner surface. In other words, the circumferential distance between the first side surface 112a and the second side surface 112b of the notch 112 at the outer surface can be greater than the circumferential distance between the first side surface 112a and the second side surface 112b of the notch 112 at the inner surface.

[0056] In operation, it is contemplated that the radial taper of the notch 112 can ensure that the opening of the notch 112 at the inner surface is smaller than the opening of the notch 112 at the outer surface of the crown. It is further contemplated that this difference in opening sizes can increase the velocity of drilling fluid at the inner surface as it passes to the outside surface of the crown. Thus, as explained above, it is contemplated that the radial taper of the notch 112 can provide for more efficient flushing of cuttings and cooling of the cutting face. Furthermore, it is contemplated that the increasing width of the notch 112 can also help ensure that debris does not jam or clog in the notch 112 as drilling fluid forces it from the inner surface to the outer surface.

[0057] Optionally, in some aspects, the radial taper of the notch 112 can be formed by a tapered second side surface 112b. Alternatively, in other aspects, it is contemplated that the first side surface 112a can be tapered. For example, it is contemplated that the first side surface 112a can taper from the inner surface to the outer surface in a direction generally counter-clockwise around the circumference of the cutting face. Optionally, in some aspects, the first side surface 112a and the second side surface 112b can both comprise a taper extending from the inner surface to the outer surface in a direction generally clockwise around the circumference of the cutting face. In these aspects, it is contemplated that the radial taper of the second side surface 112b can have a larger taper than the first side surface 112a in a manner that the width of the notch 112 increases as the notch 112 extends from the inner surface to the outer surface.

[0058] Optionally, in exemplary aspects, the top surface 112c of the notch 112 can taper from the inner surface to the outer surface in a direction generally from the cutting face toward the shank. In other words, it is contemplated that the longitudinal dimension of the notch 112 can increase as the notch 112 extends from the inner surface to the outer surface of the crown. Thus, in some aspects, it is contemplated that the longitudinal dimension of the notch 112 at the outer

surface can be greater than the longitudinal dimension of the notch 112 at the inner surface. In other words, it is contemplated that the notch 112 can extend into the cutting face a first distance at the inner surface and extend into the cutting face a second distance at the outer surface, where the second distance is greater than the first distance.

[0059] In use, it is contemplated that the axial taper of the notch 112 can help ensure that the opening of the notch 112 at the inner surface is smaller than the opening of the notch at the outer surface of the crown. It is contemplated that this difference in opening sizes can increase the velocity of drilling fluid at the inside surface as it passes to the outer surface of the crown. Thus, as explained above, it is contemplated that the axial-taper of the notch 112 can provide for more efficient flushing of cuttings and cooling of the cutting face. Furthermore, it is contemplated that the increasing size of the notch 112 can also help ensure that debris does not jam or clog in the notch 112 as drilling fluid forces it from the inner surface to the outer surface.

[0060] In exemplary aspects, it is contemplated that the double-tapered notch 112 can ensure that the notch 112 increases in dimension in each axis (i.e., both radially and axially) as it extends from the inner surface of the drill bit to the outer surface. The increasing size of the double-tapered notch 112 can reduce the likelihood of debris lodging within the notch 112, and thus, increase the drilling performance of the drill bit. Furthermore, as previously discussed, it is contemplated that the increasing size of the double-tapered notch 112 can help maximize the volume of matrix material at the inner surface, and thereby can increase the life of the drill bit by reducing premature drill bit wear at the inner surface.

[0061] In exemplary aspects, the drill bits 10 disclosed herein can be diamond-impregnated bits, with the diamonds impregnated within a matrix. In these aspects, it is contemplated that each drill bit 10 can comprise a plurality of selected materials, with each material being provided as a selected weight percentage of the drill bit. It is contemplated that each drill bit 10 can comprise carbon (not including diamond) in any desired amount, such as, for example and without limitation, an amount ranging from about 0.00% to about 7.00% by weight of the drill bit. In exemplary aspects, the carbon of the drill bits 10 can be provided as at least one of carbon powder and carbon fibers. It is further contemplated that each drill bit 10 can comprise chromium in any desired amount, such as, for example and without limitation, an amount ranging from about 0.00% to about 1.00% by weight of the drill bit. It is further contemplated

that each drill bit 10 can comprise cobalt in any desired amount, such as, for example and without limitation, an amount ranging from about 0.00% to about 1.00% by weight of the drill bit. Optionally, it is further contemplated that each drill bit 10 can comprise copper in any desired amount, such as, for example and without limitation, an amount ranging from about 0.00% to about 30.00% by weight of the drill bit. It is further contemplated that each drill bit 10 can comprise iron in any desired amount, such as, for example and without limitation, an amount ranging from about 50.00% to about 90.00% by weight of the drill bit. It is further contemplated that each drill bit 10 can comprise manganese in any desired amount, such as, for example and without limitation, an amount ranging from about 0.00% to about 8.00% by weight of the drill bit. It is further contemplated that each drill bit 10 can comprise molybdenum in any desired amount, such as, for example and without limitation, an amount ranging from about 0.00% to about 0.20% by weight of the drill bit. It is further contemplated that each drill bit 10 can comprise nickel in any desired amount, such as, for example and without limitation, an amount ranging from about 0.00% to about 6.00% by weight of the drill bit. It is further contemplated that each drill bit 10 can comprise silicon in any desired amount, such as, for example and without limitation, an amount ranging from about 0.00% to about 0.50% by weight of the drill bit. It is further contemplated that each drill bit 10 can comprise silicon carbide in any desired amount, such as, for example and without limitation, an amount ranging from about 0.00% to about 2.00% by weight of the drill bit. It is further contemplated that each drill bit 10 can comprise silver in any desired amount, such as, for example and without limitation, an amount ranging from about 0.00% to about 12.00% by weight of the drill bit. It is further contemplated that each drill bit 10 can comprise tin in any desired amount, such as, for example and without limitation, an amount ranging from about 0.00% to about 6.00% by weight of the drill bit. It is further contemplated that each drill bit 10 can comprise tungsten in any desired amount, such as, for example and without limitation, an amount ranging from about 0.00% to about 41.00% by weight of the drill bit. It is further contemplated that each drill bit 10 can comprise tungsten carbide in any desired amount, such as, for example and without limitation, an amount ranging from about 0.00% to about 35.00% by weight of the drill bit. It is further contemplated that each drill bit 10 can comprise zinc in any desired amount, such as, for example and without limitation, an amount ranging from about 0.00% to about 24.00% by weight of the drill bit. It is further contemplated that the matrix of the full face drill bits disclosed herein can be configured to form

supporting structures behind the diamonds within the drill bits, thereby preventing the polishing of the impregnated diamonds during operation.

[0062] It is further contemplated to radially vary the composition of the matrix to provide a more consistent wear across the operative drilling face of the crown of the drill. In one aspect, it is contemplated that the crown can be divided between at least three integrally adjoining sections that extend from the inner surface of the crown to the outer surface of the crown in a direction generally normal to the inner surface of the crown. The first section is generally cylindrical in shape and extends outwardly from the formed inner surface of the crown to a first surface spaced radially a desired distance from the inner surface. The third, outer, section is generally cylindrical in shape and extends inwardly from the formed outer surface of the crown to a third surface spaced radially a desired distance from the outer surface. Finally, in this example, at least one second section is provided that is generally cylindrical and extends radially between and is integrally formed thereto the first and second sections. In one aspect, the at least one second section can comprise a single second section or a plurality of radially layered second sections. In this example, at least one of the plurality of radially layered second sections would have a matrix composition that wears at a rate that differs from at another of the radially layered second sections. In an exemplary aspect, as a conventional bit wears more proximate the inner and outer surfaces of the crown in operation due to the decreased support of the diamonds or other cutting elements that are impregnated within the matrix near the respective inner and outer diameters, it is contemplated that the respective first and third sections could be formed from a matrix composition that has a higher wear rate than the at least one second section. Forming the second section of a matrix material that has a decreased wear is beneficial as the bit will require less energy and create a more uniform wear pattern across the crown in operation.

[0063] In exemplary aspects, and with reference to Figure 5, the drill bits disclosed herein can be provided as part of a drilling system 500. In these aspects, it is contemplated that the drilling system 500 can comprise a drill head 510, a mast 520, a drill rig 530, and a drill string 550 configured to be secured to and rotated by the drill rig, as are conventionally known in the art. It is further contemplated that a drill bit 560 can be operatively coupled to an end of the drill string 550. For example, it is contemplated that a drill bit 10 as disclosed herein can be coupled to the drill string 550. In operation, as the drill string 550 is rotated and pushed by the drill rig

530, it is contemplated that the drill bit 560 (corresponding to a drill bit 10 as disclosed herein) can grind away materials in a formation 570.

[0064] In use, it is contemplated that the absence (or minimization) of waterway slots or windows in the disclosed drill bits can increase the strength of the drill bits (as compared to conventional drill bits having such slots or windows). It is further contemplated that the drill bits disclosed herein can permit improved efficiency of flushing and improved cooling of the drill bit by increasing the velocity of the cooling fluid proximate the bit face and directing the fluid across the bit face without losing fluid to the waterway slots, channels, or windows.

[0065] Due to the increased strength and improved flushing efficiency of the annular drill bits disclosed herein, it is contemplated that the disclosed annular drill bits can show less wear and have an increased functional product life compared to known drill bits. It is further contemplated that the increased strength and flushing of the disclosed full face drill bits can permit the manufacture of taller annular crowns, thereby further extending the functional product life of the drill bits.

Experimental Examples

[0066] In one experimental example, during normal operation, an annular drill bit as disclosed herein was shown to require about 25% less water than conventional drill bits.

[0067] In another experimental example, during normal operation, an annular drill bit as disclosed herein was shown to experience a fluid velocity at its face that is over three times higher than the velocity experienced at the face of conventional drill bit designs.

[0068] In still another experimental example, it was shown that a drill bit having no waterway, as disclosed herein, had a substantially constant velocity at any impregnation depth.

Exemplary Aspects

[0069] In exemplary aspects, a drill bit for forming a hole in a formation is provided, the drill bit having a longitudinal axis and comprising: a shank; an annular crown having a cutting face, an inner surface, and an outer surface, the full face crown and the shank cooperating to define an interior space about the longitudinal axis, wherein the annular crown defines a plurality of inner channels spaced circumferentially about the inner surface of the annular crown, wherein the annular crown defines a plurality of outer channels spaced circumferentially about

the outer surface of the annular crown, and wherein the annular crown completely circumferentially encloses the interior space.

[0070] In another exemplary aspect, the annular crown does not comprise a waterway extending radially from the inner surface of the annular crown to the outer surface of the annular crown. In an alternative exemplary aspect, the annular crown comprises a single waterway extending radially from the inner surface of the annular crown to the outer surface of the annular crown.

[0071] In another exemplary aspect, the annular crown can have a radial thickness between the inner surface and the outer surface, wherein each inner channel of the plurality of inner channels has a radial dimension less than the radial thickness of the annular crown, and wherein each outer channel of the plurality of outer channels has a radial dimension less than the radial thickness of the annular crown.

[0072] In another exemplary aspect, the ratio between the radial thickness of the annular crown and the radial dimension of the plurality of inner channels can range from about 1.5:1 to about 3.5:1.

[0073] In another exemplary aspect, the ratio between the radial thickness of the annular crown and the radial dimension of the plurality of outer channels can range from about 1.5:1 to about 3.5:1.

[0074] In another exemplary aspect, the radial dimension of the plurality of inner channels can be greater than the radial dimension of the plurality of outer channels.

[0075] In another exemplary aspect, the number of inner channels can be the same as the number of outer channels.

[0076] In another exemplary aspect, the number of inner channels can be greater than the number of outer channels.

[0077] In another exemplary aspect, the number of inner channels can be less than the number of outer channels.

[0078] In another exemplary aspect, each outer channel of the plurality of outer channels can be positioned circumferentially between sequential inner channels of the plurality of inner channels.

[0079] In additional exemplary aspects, a drilling system can be provided, the drilling system comprising: a drill rig; a drill string configured to be secured to and rotated by the drill rig; and a drill bit for forming a hole in a formation, the drill bit having a longitudinal axis and comprising: a shank; an annular crown having a cutting face, an inner surface, and an outer surface, the full face crown and the shank cooperating to define an interior space about the longitudinal axis, wherein the annular crown defines a plurality of inner channels spaced circumferentially about the inner surface of the annular crown, wherein the annular crown defines a plurality of outer channels spaced circumferentially about the outer surface of the annular crown, and wherein the annular crown completely circumferentially encloses the interior space.

[0080] In another exemplary aspect, the annular crown of the drill bit does not comprise a waterway extending radially from the inner surface of the annular crown to the outer surface of the annular crown. In an alternative exemplary aspect, the annular crown comprises a single waterway extending radially from the inner surface of the annular crown to the outer surface of the annular crown.

[0081] In another exemplary aspect, the annular crown of the drill bit can have a radial thickness between the inner surface and the outer surface, wherein each inner channel of the plurality of inner channels has a radial dimension less than the radial thickness of the annular crown, and wherein each outer channel of the plurality of outer channels has a radial dimension less than the radial thickness of the annular crown.

[0082] In another exemplary aspect, the ratio between the radial thickness of the annular crown of the drill bit and the radial dimension of the plurality of inner channels of the annular crown can range from about 1.5:1 to about 3.5:1.

[0083] In another exemplary aspect, the ratio between the radial thickness of the annular crown of the drill bit and the radial dimension of the plurality of outer channels of the drill bit can range from about 1.5:1 to about 3.5:1.

[0084] In another exemplary aspect, the radial dimension of the plurality of inner channels of the drill bit can be greater than the radial dimension of the plurality of outer channels of the drill bit.

[0085] In another exemplary aspect, the number of inner channels of the drill bit can be the same as the number of outer channels of the drill bit.

[0086] In another exemplary aspect, the number of inner channels of the drill bit can be greater than the number of outer channels of the drill bit.

[0087] In another exemplary aspect, the number of inner channels of the drill bit can be less than the number of outer channels of the drill bit.

[0088] In another exemplary aspect, each outer channel of the plurality of outer channels of the drill bit can be positioned circumferentially between sequential inner channels of the plurality of inner channels of the drill bit.

[0089] Although several embodiments of the invention have been disclosed in the foregoing specification, it is understood by those skilled in the art that many modifications and other embodiments of the invention will come to mind to which the invention pertains, having the benefit of the teaching presented in the foregoing description and associated drawings. It is thus understood that the invention is not limited to the specific embodiments disclosed hereinabove, and that many modifications and other embodiments are intended to be included within the scope of the appended claims. Moreover, although specific terms are employed herein, as well as in the claims which follow, they are used only in a generic and descriptive sense, and not for the purposes of limiting the described invention, nor the claims which follow.

CLAIMS

What is claimed is:

1. A drill bit for forming a hole in a formation, the drill bit having a longitudinal axis and comprising:
 - a shank;
 - an annular crown having a cutting face, an inner surface, and an outer surface, the full face crown and the shank cooperating to define an interior space about the longitudinal axis, wherein the annular crown defines a plurality of inner channels spaced circumferentially about the inner surface of the annular crown,
 - wherein the annular crown defines a plurality of outer channels spaced circumferentially about the outer surface of the annular crown, and
 - wherein the annular crown completely circumferentially encloses the interior space.
2. The drill bit of claim 1, wherein the annular crown does not comprise a waterway extending radially from the inner surface of the annular crown to the outer surface of the annular crown.
3. The drill bit of claim 1, wherein the annular crown has a radial thickness between the inner surface and the outer surface, wherein each inner channel of the plurality of inner channels has a radial dimension less than the radial thickness of the annular crown, and wherein each outer channel of the plurality of outer channels has a radial dimension less than the radial thickness of the annular crown.
4. The drill bit of claim 3, wherein the ratio between the radial thickness of the annular crown and the radial dimension of the plurality of inner channels ranges from about 1.5:1 to about 3.5:1.
5. The drill bit of claim 4, wherein the ratio between the radial thickness of the annular crown and the radial dimension of the plurality of outer channels ranges from about 1.5:1 to about 3.5:1.
6. The drill bit of claim 3, wherein the radial dimension of the plurality of inner channels is greater than the radial dimension of the plurality of outer channels.

7. The drill bit of claim 1, wherein the number of inner channels is the same as the number of outer channels.
8. The drill bit of claim 1, wherein the number of inner channels is greater than the number of outer channels.
9. The drill bit of claim 1, wherein the number of inner channels is less than the number of outer channels.
10. The drill bit of claim 1, wherein each outer channel of the plurality of outer channels is positioned circumferentially between sequential inner channels of the plurality of inner channels.
11. The drill bit of claim 1, wherein the annular crown comprises a single waterway extending radially from the inner surface of the annular crown to the outer surface of the annular crown.
12. A drilling system comprising:
 - a drill rig;
 - a drill string configured to be secured to and rotated by the drill rig; and
 - a drill bit for forming a hole in a formation, the drill bit having a longitudinal axis and comprising:
 - a shank;
 - an annular crown having a cutting face, an inner surface, and an outer surface, the full face crown and the shank cooperating to define an interior space about the longitudinal axis,
 - wherein the annular crown defines a plurality of inner channels spaced circumferentially about the inner surface of the annular crown,
 - wherein the annular crown defines a plurality of outer channels spaced circumferentially about the outer surface of the annular crown, and
 - wherein the annular crown completely circumferentially encloses the interior space.

13. The drilling system of claim 12, wherein the annular crown of the drill bit does not comprise a waterway extending radially from the inner surface of the annular crown to the outer surface of the annular crown.

14. The drilling system of claim 12, wherein the annular crown of the drill bit has a radial thickness between the inner surface and the outer surface, wherein each inner channel of the plurality of inner channels has a radial dimension less than the radial thickness of the annular crown, and wherein each outer channel of the plurality of outer channels has a radial dimension less than the radial thickness of the annular crown.

15. The drilling system of claim 14, wherein the ratio between the radial thickness of the annular crown of the drill bit and the radial dimension of the plurality of inner channels of the annular crown ranges from about 1.5:1 to about 3.5:1.

16. The drilling system of claim 15, wherein the ratio between the radial thickness of the annular crown of the drill bit and the radial dimension of the plurality of outer channels of the drill bit ranges from about 1.5:1 to about 3.5:1.

17. The drilling system of claim 14, wherein the radial dimension of the plurality of inner channels of the drill bit is greater than the radial dimension of the plurality of outer channels of the drill bit.

18. The drilling system of claim 12, wherein the number of inner channels of the drill bit is the same as the number of outer channels of the drill bit.

19. The drilling system of claim 12, wherein the number of inner channels of the drill bit is greater than the number of outer channels of the drill bit.

20. The drilling system of claim 12, wherein the number of inner channels of the drill bit is less than the number of outer channels of the drill bit.

21. The drilling system of claim 12, wherein each outer channel of the plurality of outer channels of the drill bit is positioned circumferentially between sequential inner channels of the plurality of inner channels of the drill bit.

22. The drilling system of claim 12, wherein the annular crown comprises a single waterway extending radially from the inner surface of the annular crown to the outer surface of the annular crown.

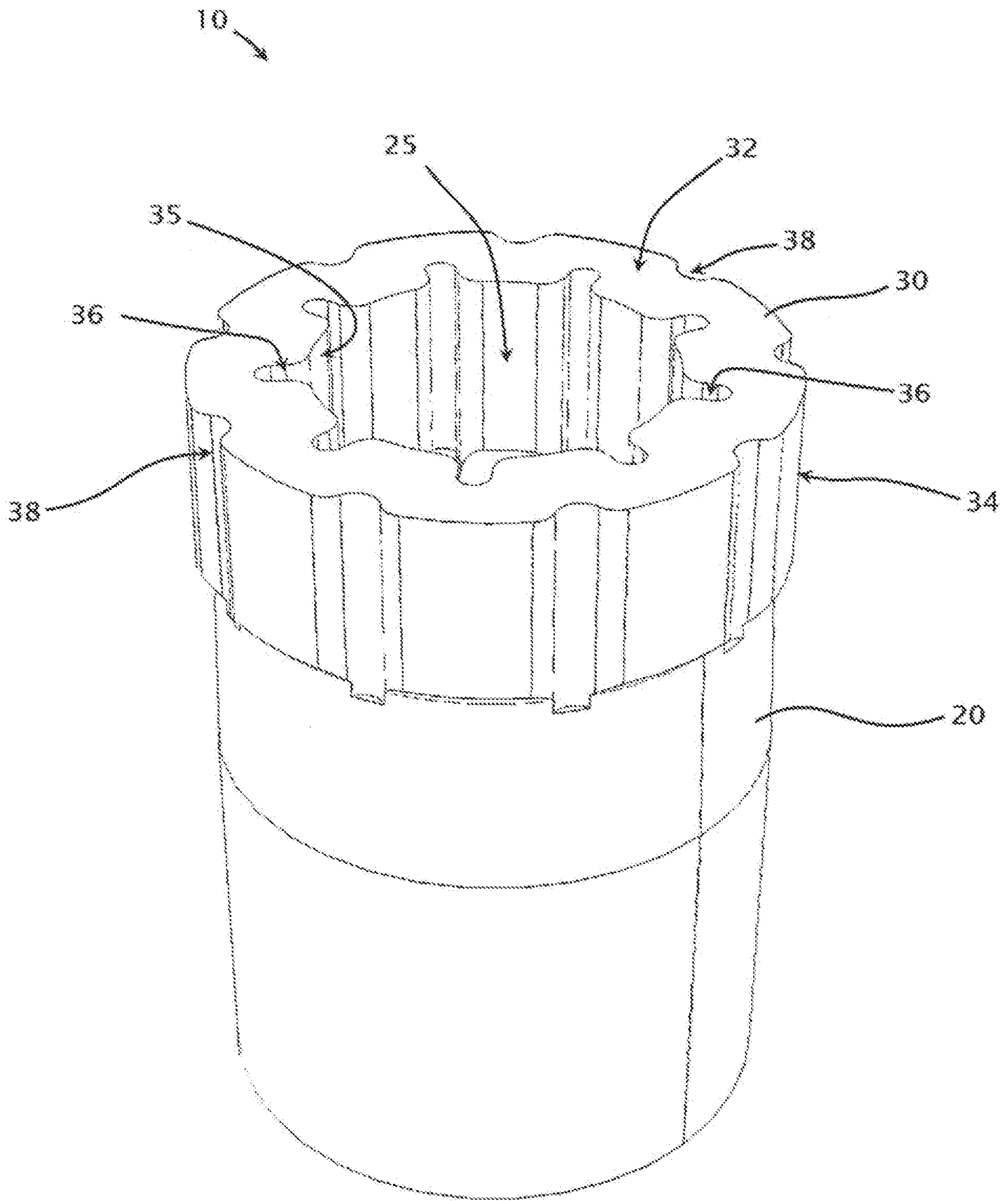

FIGURE 1A

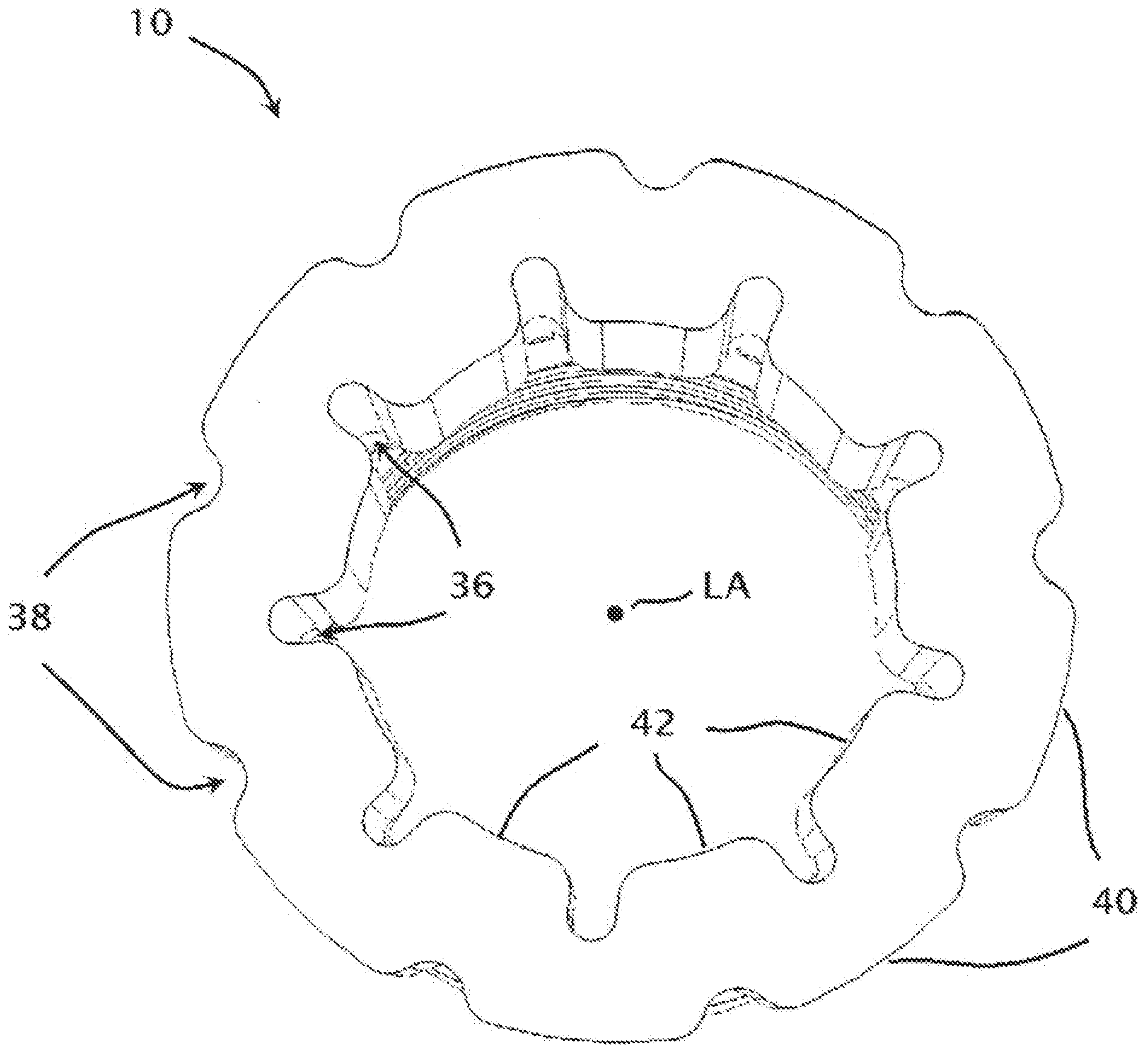

FIGURE 1B

3/11

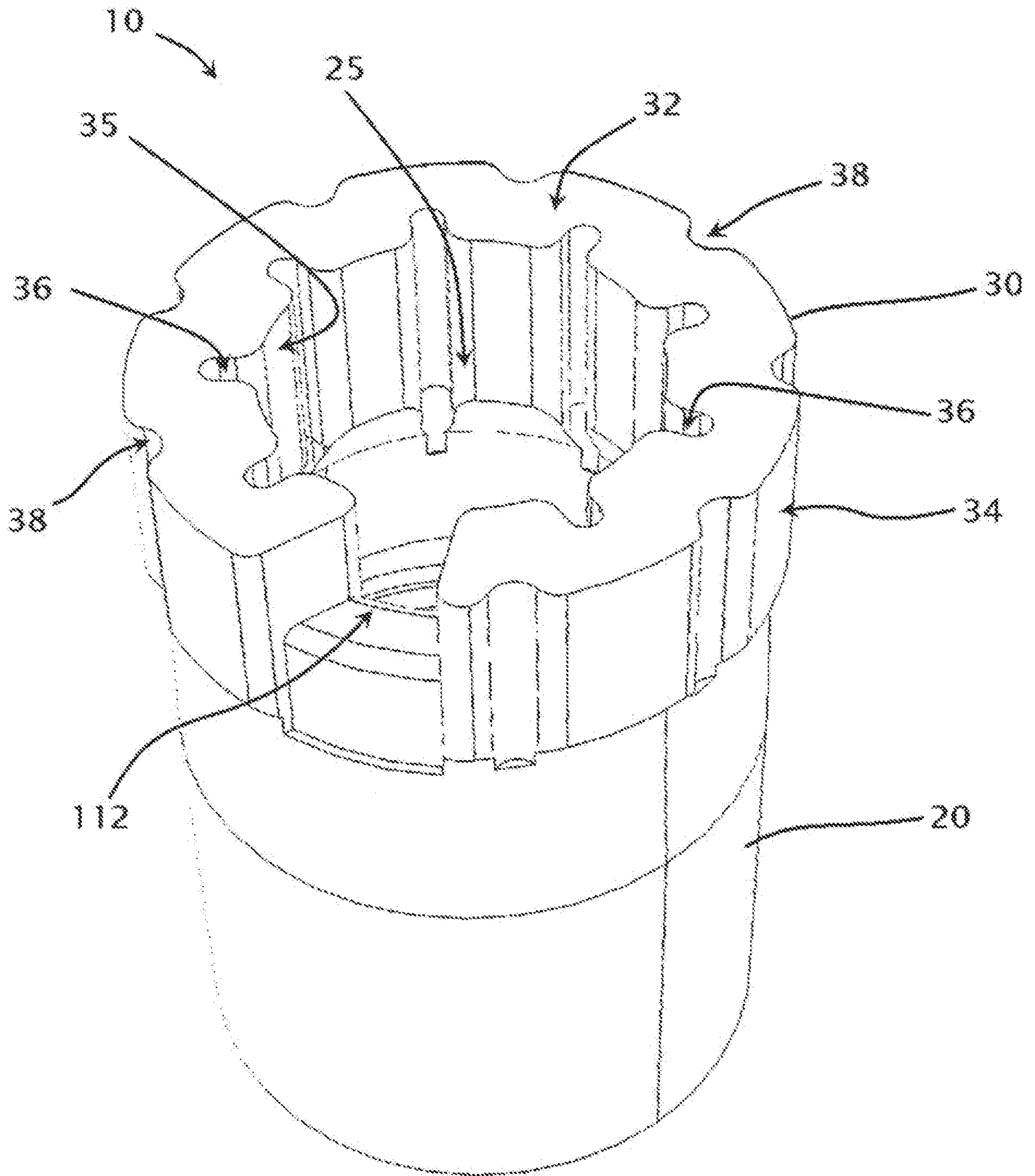

FIGURE 2A

4/11

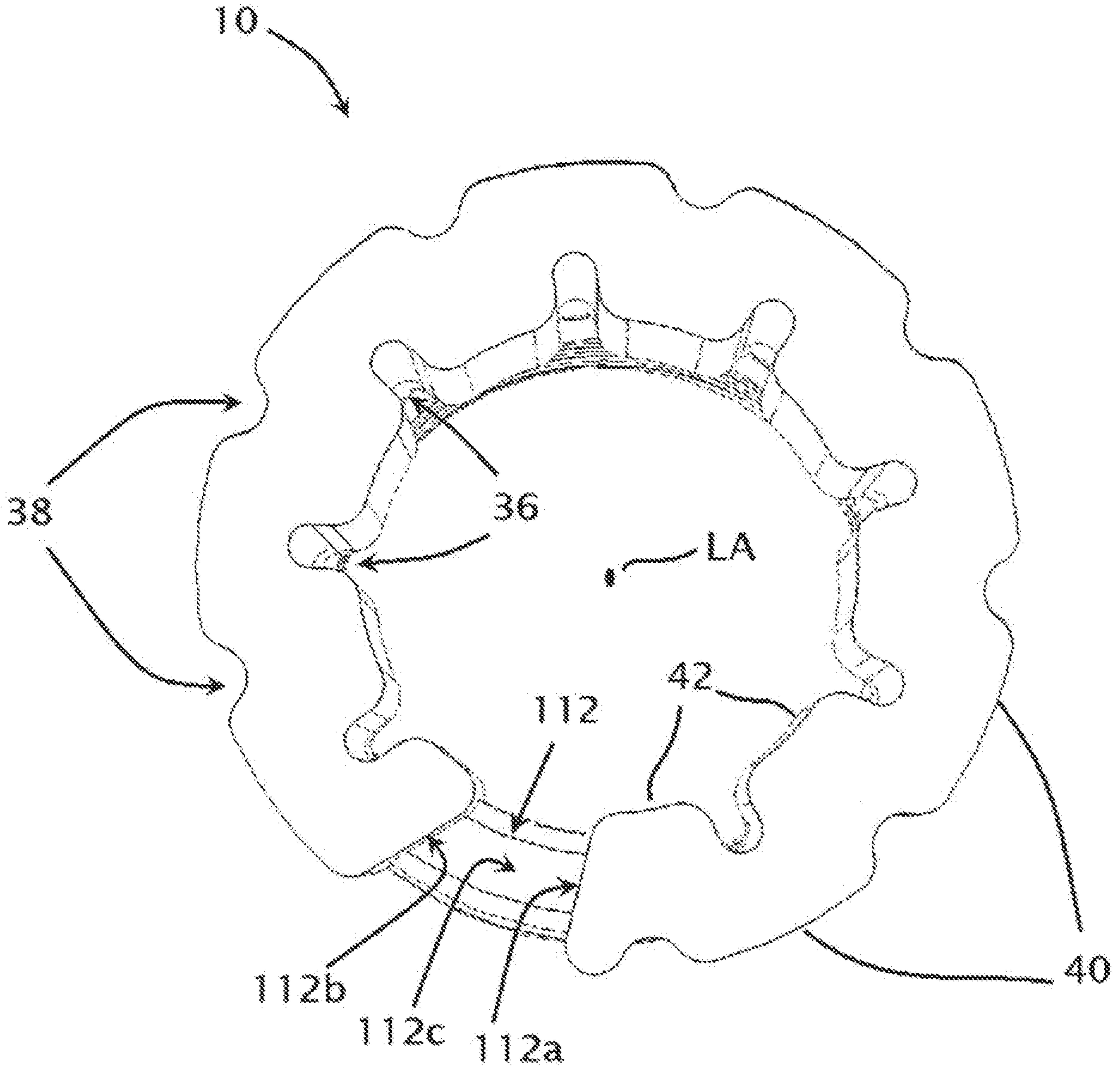

FIGURE 2B

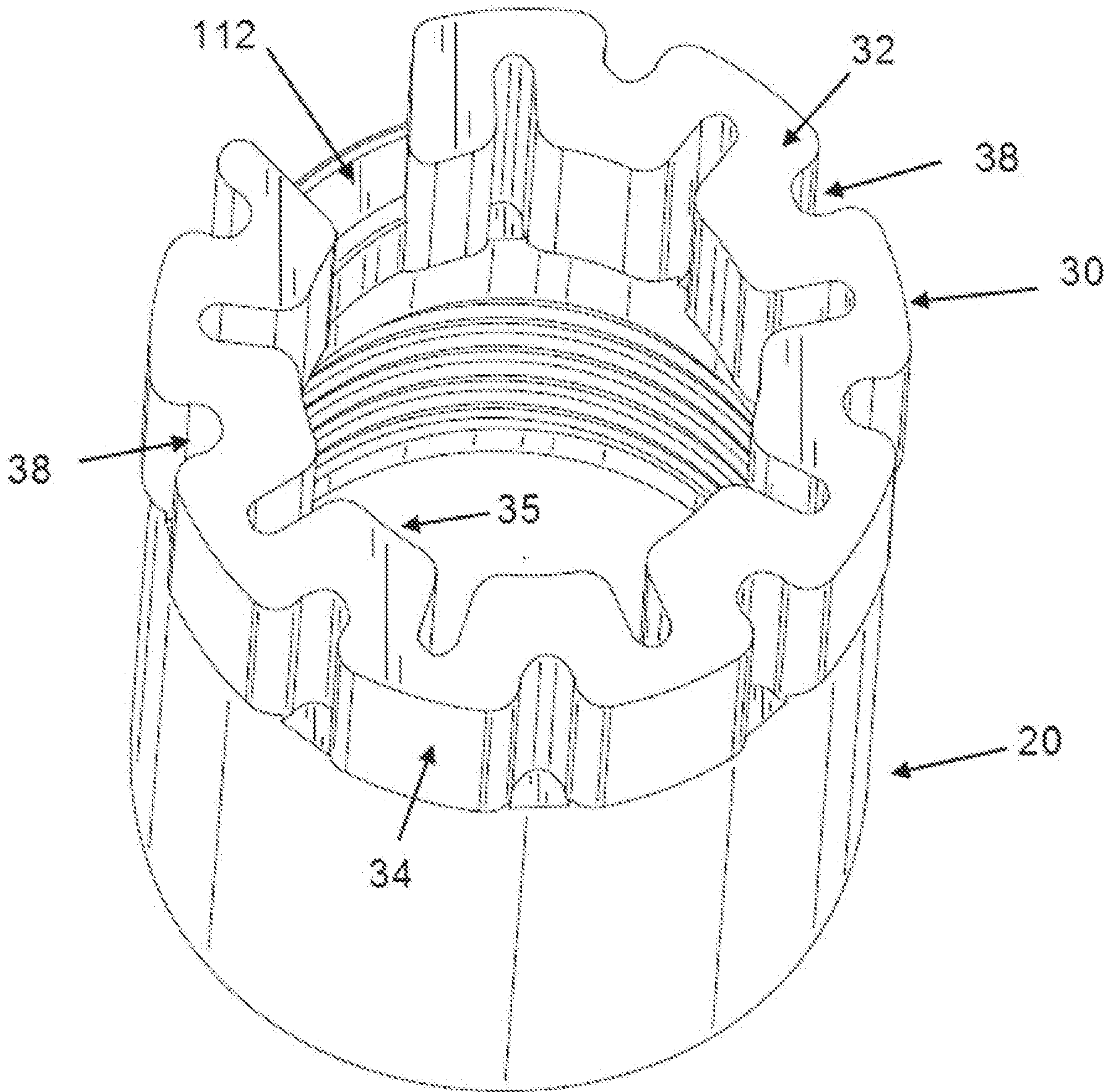

Fig. 3

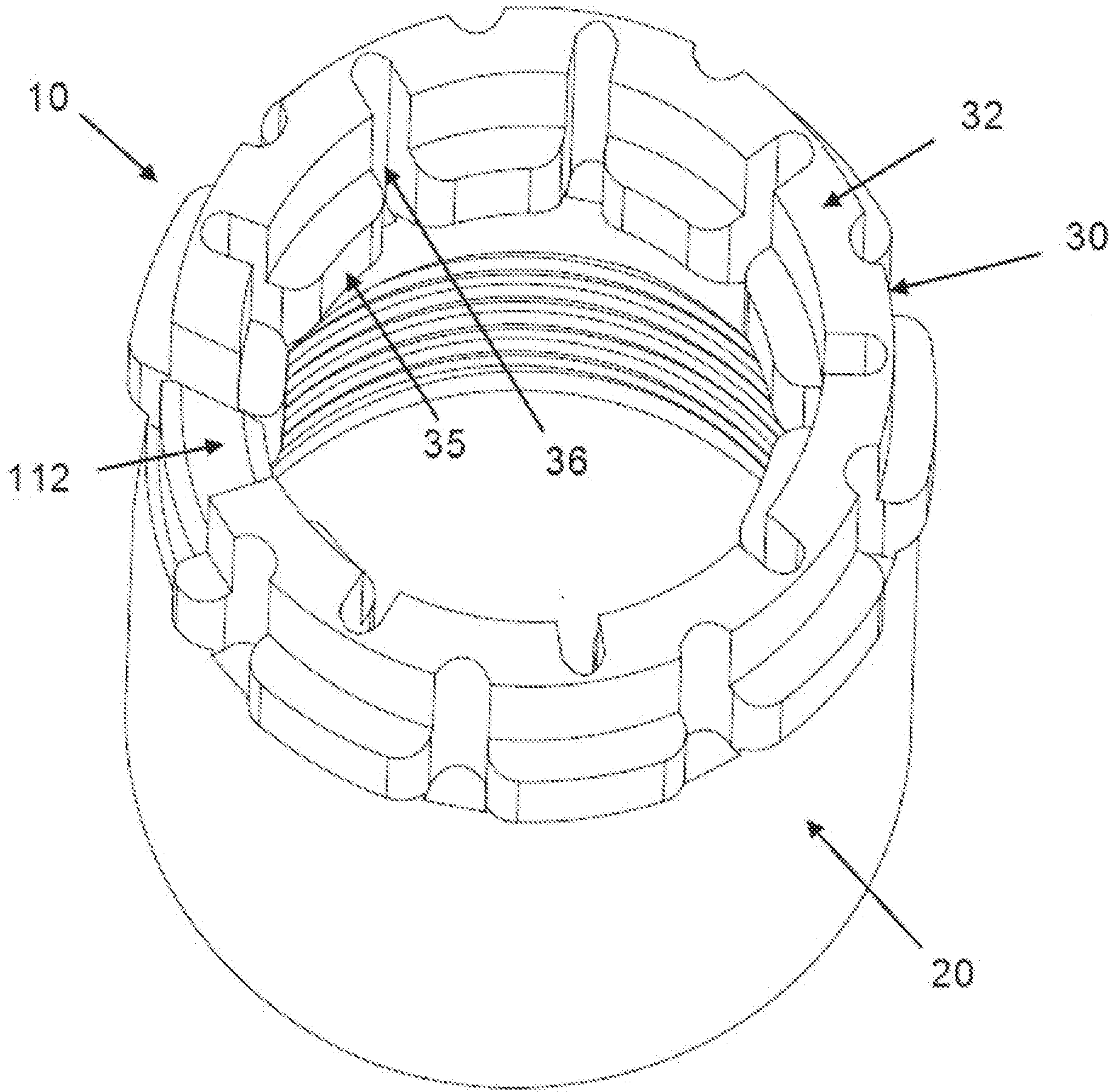

Fig. 4

7/11

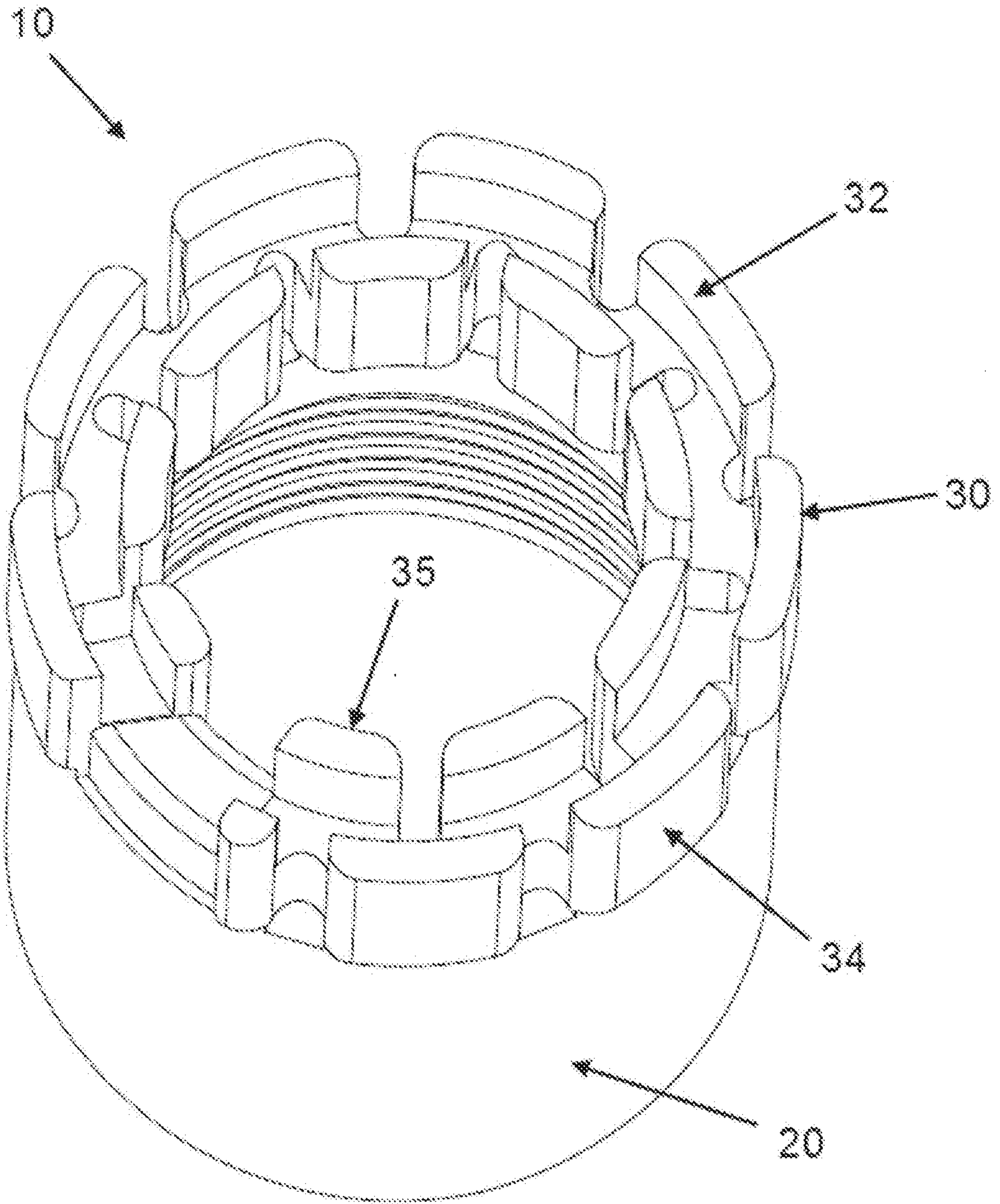

Fig. 5

8/11

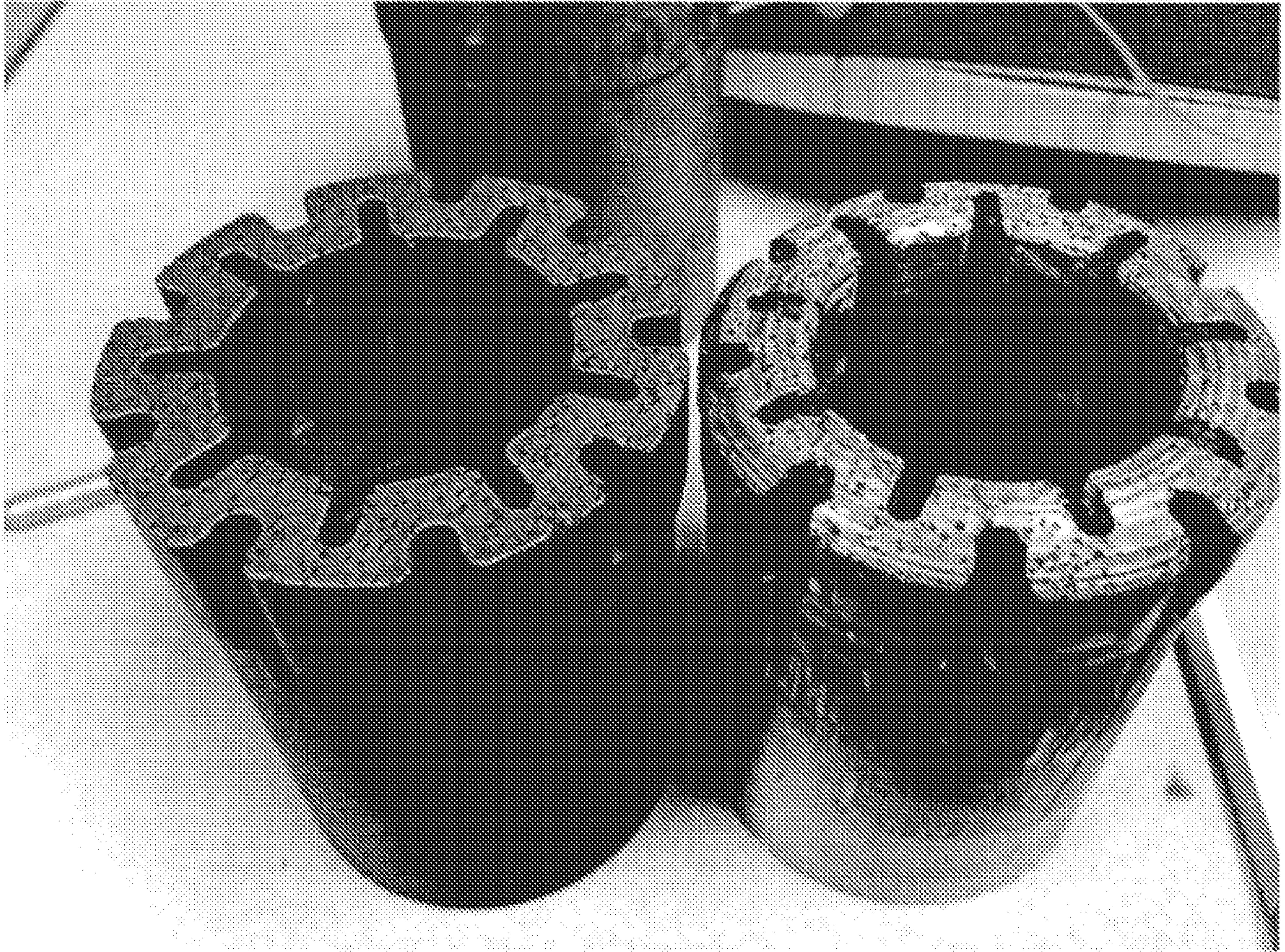

FIGURE 6

9/11

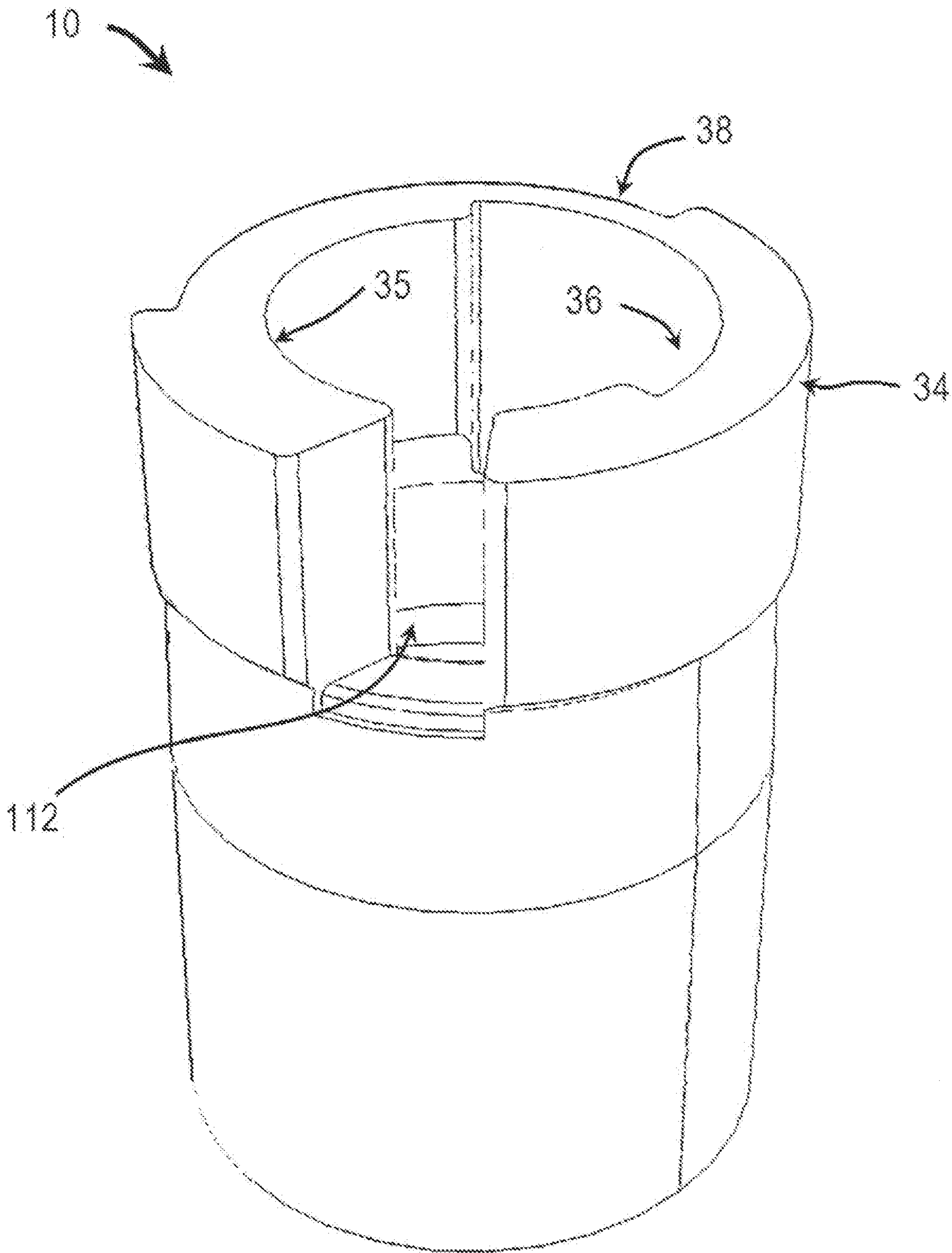

FIGURE 7

10/11

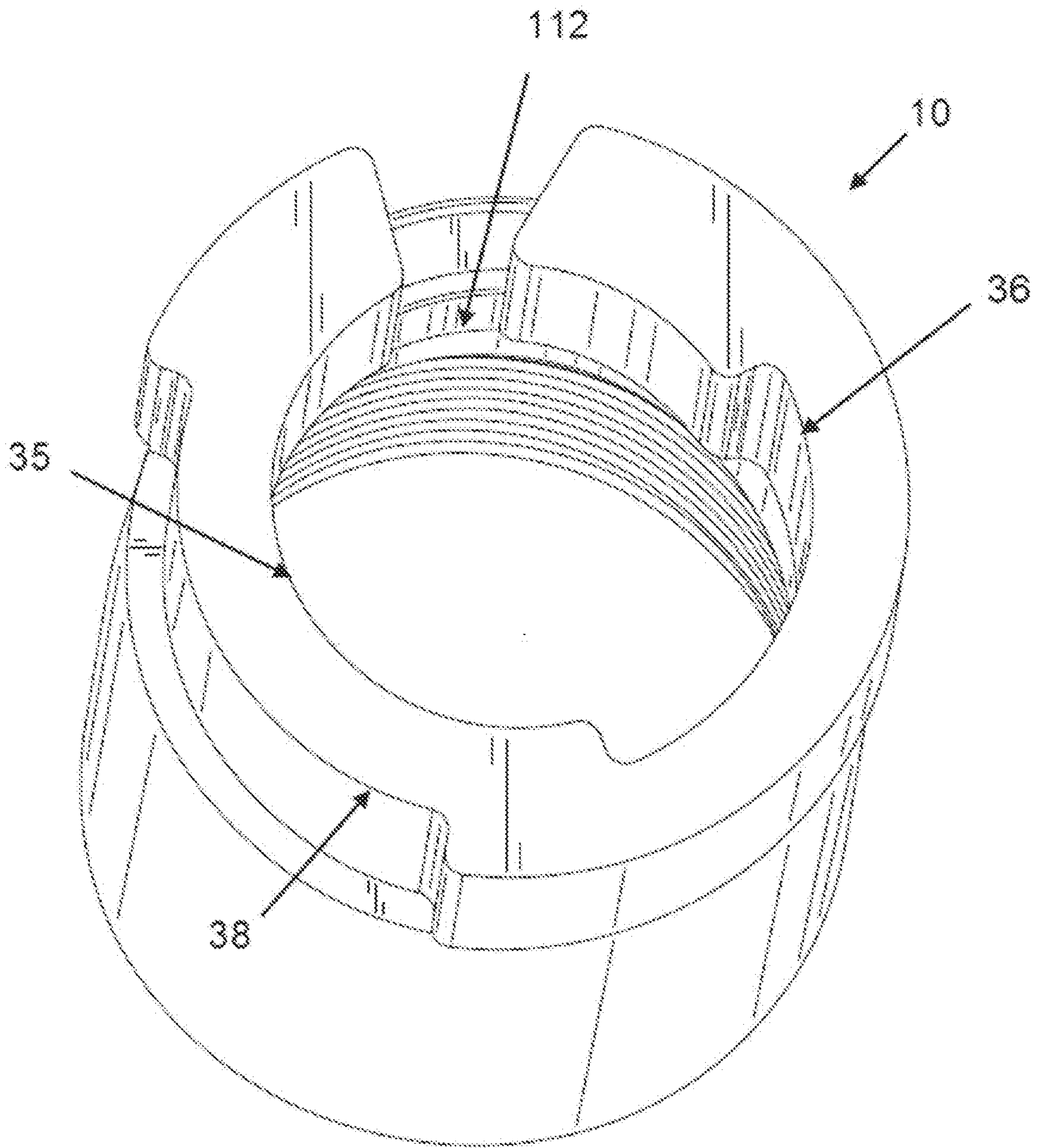

Fig. 8

11/11

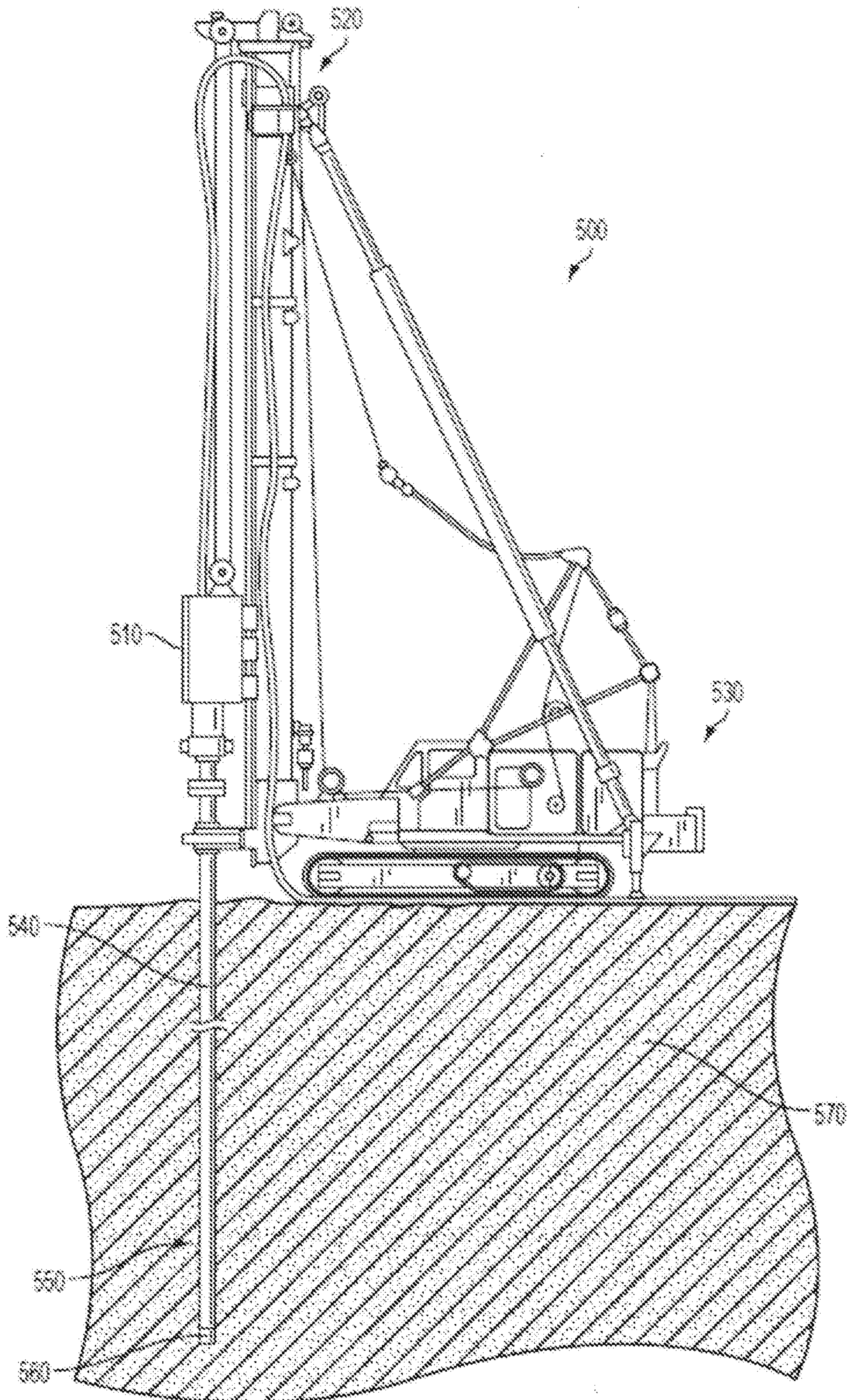

FIGURE 9

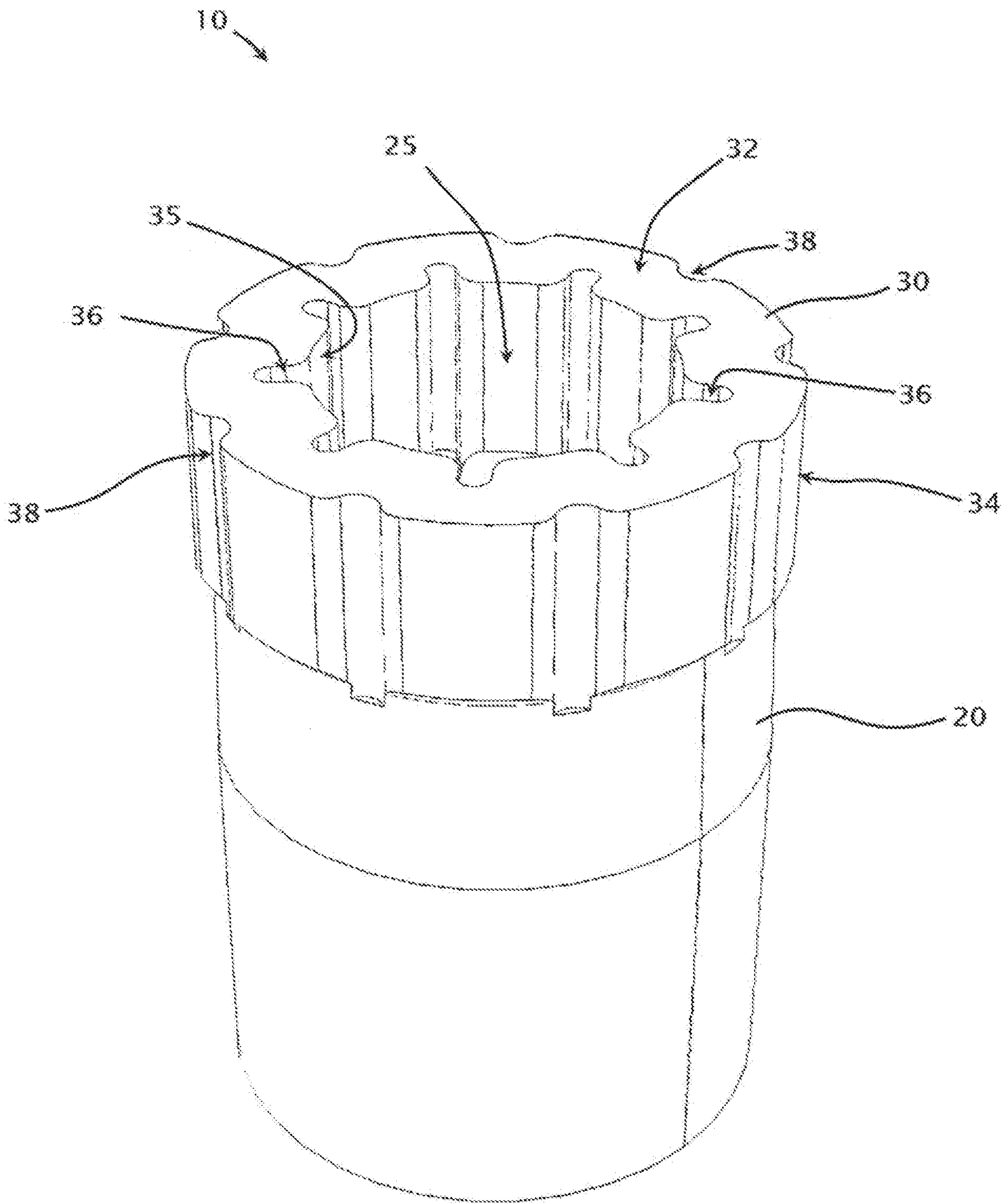

FIGURE 1A