

(12) INTERNATIONAL APPLICATION PUBLISHED UNDER THE PATENT COOPERATION TREATY (PCT)

(19) World Intellectual Property
Organization
International Bureau(10) International Publication Number
WO 2017/014991 A1(43) International Publication Date
26 January 2017 (26.01.2017)

- (51) **International Patent Classification:**
B60C 23/04 (2006.01)
- (21) **International Application Number:**
PCT/US2016/041861
- (22) **International Filing Date:**
12 July 2016 (12.07.2016)
- (25) **Filing Language:** English
- (26) **Publication Language:** English
- (30) **Priority Data:**
14/803,641 20 July 2015 (20.07.2015) US
- (71) **Applicant:** BENDIX COMMERCIAL VEHICLE SYSTEMS LLC [US/US]; 901 Cleveland Street, Elyria, OH 44035 (US).
- (72) **Inventors:** PATTERSON, Robert, G.; Bendix Commercial Vehicle Systems LLC, 901 Cleveland Street, Elyria, OH (US). LAMMERS, Shawn, D.; Bendix Commercial Vehicle Systems LLC, 901 Cleveland Street, Elyria, OH (US).
- (74) **Agents:** GREENLY, Cheryl, L. et al.; Bendix Commercial Vehicle Systems LLC, 901 Cleveland Street, Elyria, OH 44035 (US).
- (81) **Designated States** (*unless otherwise indicated, for every kind of national protection available*): AE, AG, AL, AM, AO, AT, AU, AZ, BA, BB, BG, BH, BN, BR, BW, BY,

BZ, CA, CH, CL, CN, CO, CR, CU, CZ, DE, DK, DM, DO, DZ, EC, EE, EG, ES, FI, GB, GD, GE, GH, GM, GT, HN, HR, HU, ID, IL, IN, IR, IS, JP, KE, KG, KN, KP, KR, KZ, LA, LC, LK, LR, LS, LU, LY, MA, MD, ME, MG, MK, MN, MW, MX, MY, MZ, NA, NG, NI, NO, NZ, OM, PA, PE, PG, PH, PL, PT, QA, RO, RS, RU, RW, SA, SC, SD, SE, SG, SK, SL, SM, ST, SV, SY, TH, TJ, TM, TN, TR, TT, TZ, UA, UG, US, UZ, VC, VN, ZA, ZM, ZW.

- (84) **Designated States** (*unless otherwise indicated, for every kind of regional protection available*): ARIPO (BW, GH, GM, KE, LR, LS, MW, MZ, NA, RW, SD, SL, ST, SZ, TZ, UG, ZM, ZW), Eurasian (AM, AZ, BY, KG, KZ, RU, TJ, TM), European (AL, AT, BE, BG, CH, CY, CZ, DE, DK, EE, ES, FI, FR, GB, GR, HR, HU, IE, IS, IT, LT, LU, LV, MC, MK, MT, NL, NO, PL, PT, RO, RS, SE, SI, SK, SM, TR), OAPI (BF, BJ, CF, CG, CI, CM, GA, GN, GQ, GW, KM, ML, MR, NE, SN, TD, TG).

Declarations under Rule 4.17:

- *as to applicant's entitlement to apply for and be granted a patent (Rule 4.17(ii))*
- *as to the applicant's entitlement to claim the priority of the earlier application (Rule 4.17(iii))*
- *of inventorship (Rule 4.17(iv))*

Published:

- *with international search report (Art. 21(3))*

(54) **Title:** TRANSMITTING DEVICE WITH ANTENNA

Figure 2

(57) **Abstract:** Various examples of a transmitting device with an antenna are disclosed. In one example, a transmitting device comprises a planar circuit board; a sensor mounted on the planar circuit board; a transmitter mounted on the planar circuit board and in communication with the sensor, the transmitter configured to periodically transmit signals containing a plurality of packets; and an antenna mounted on the planar circuit board and in electrical communication with the transmitter for transmitting the signals containing the plurality of packets. The antenna comprises a first end connected to the planar circuit board and a first support section; a meander line section connected to the first support section and a second support section and lying in a plane parallel with the circuit board; a second end connected to the second support section and an electrical ground.

WO 2017/014991 A1

TRANSMITTING DEVICE WITH ANTENNA

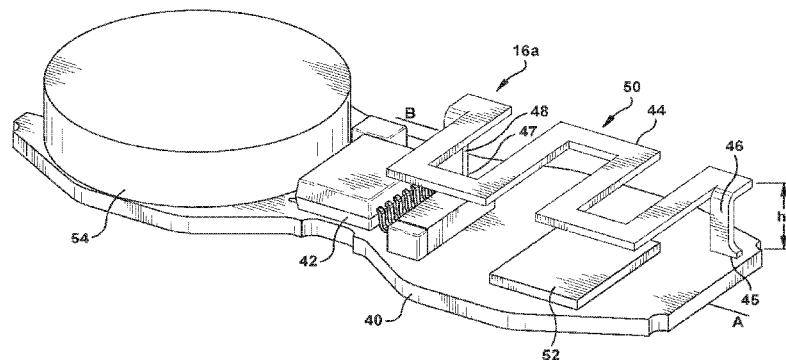
Background

[0001] The present invention relates to embodiments of a transmitting device with an antenna, such as used in tire pressure sensing and other wireless vehicle sensing systems. Conventional tire pressure sensors are installed within tires of the vehicle or on a valve stem and include radio frequency (RF) transmitters. The sensors transmit periodic signals indicating tire conditions (e.g., pressure, temperature, etc.) of the respective tires of the vehicle. Receiving antennas placed at multiple locations throughout the vehicle receive the tire condition signals from the various transmitters.

[0002] A tire pressure monitoring system, such as used on a commercial vehicle, may include multiple receiving antennas since the tire pressure sensors may be separated by large distances from each other. Signals from tire pressure sensors located within the pressurized tire may suffer from attenuation as the signal passes through the tire sidewalls. The antenna may also be detuned based on its proximity to the edge of a rim inside a steel belted tire. In addition, the attenuation of the signal affects the number of receiving antennas required on the vehicle. There is a need for an improved transmitting device to address these issues.

Summary

[0003] An example of a transmitting device comprises a planar circuit board; a sensor mounted on the planar circuit board; a transmitter mounted on the planar circuit board and in communication with the sensor, the transmitter configured to periodically transmit signals containing a plurality of packets; and an antenna mounted on the planar circuit board and in electrical communication with the transmitter for transmitting the signals containing the plurality of packets. The antenna comprises a first end connected to the planar circuit board

and a first support section; a meander line section connected to the first support section and a second support section and lying in a plane parallel with the circuit board; a second end connected to the second support section and an electrical ground.

[0004] In accordance with another aspect, a system for monitoring a condition on a vehicle comprises a plurality of transmitting devices, each of the plurality of transmitting devices comprising: a planar circuit board; a sensor mounted on the planar circuit board; a transmitter mounted on the planar circuit board and in communication with the sensor, the transmitter configured to periodically wirelessly transmit signals containing the plurality of packets; and an antenna mounted on the planar circuit board and in communication with the transmitter for transmitting the signals. The antenna comprises a first end connected to the planar circuit board and a first support section; a meander line section connected to the first support section and a second support section; a second end connected to the second support section and a ground. The system comprises a single receiver for receiving the plurality of packets from the plurality of transmitting devices.

[0004a] In accordance with another aspect, a transmitting device comprising: a planar circuit board; a sensor mounted on the planar circuit board configured to sense a vehicle condition and form a plurality of data packets, the data packets including the vehicle condition; a transmitter mounted on the planar circuit board and in electrical communication with the sensor, the transmitter configured to periodically wirelessly transmit signals containing the plurality of data packets; and an antenna mounted on the planar circuit board and in electrical communication with the transmitter for transmitting signals containing the plurality of data packets, the antenna comprising: a first end connected to the planar circuit board and a first support section; a meander line section connected to the first support section and a second support section and lying in a plane substantially parallel with and vertically above the circuit board; a second end connected to the second support section and an electrical ground.

[0004b] In accordance with another aspect, a transmitting device comprising: a planar circuit board; a sensor mounted on the planar circuit board configured to sense a vehicle condition and form a plurality of data packets, the data packets including the vehicle condition; a transmitter mounted on the planar circuit board and in electrical communication with the sensor, the transmitter configured to periodically wirelessly transmit signals containing the plurality of data packets; an antenna mounted on the planar circuit board and in electrical communication with the transmitter for transmitting signals containing the plurality of data packets, the antenna comprising: a first end connected to the planar circuit board and a first support section; a meander line section connected to the first support section and a second support section and lying in a plane substantially parallel with the circuit board; a second end

connected to the second support section and an electrical ground; and a control circuit in communication with the transmitter and the sensor, wherein the sensor is configured for detecting an ambient temperature and the control circuit is capable of lowering a transmission power level in response to a temperature less than a temperature threshold.

[0004c] In accordance with another aspect, a system for monitoring a condition on a vehicle comprising: a plurality of transmitting devices; wherein each of the plurality of transmitting devices comprises: a planar circuit board; a sensor mounted on the planar circuit board configured to sense a vehicle condition and form a plurality of data packets, the data packets including the vehicle condition; a transmitter mounted on the planar circuit board and in communication with the sensor, the transmitter configured to periodically wirelessly transmit signals containing the plurality of data packets; and an antenna mounted on the planar circuit board and in communication with the transmitter for transmitting the signals containing the plurality of data packets, the antenna comprising: a first end connected to the planar circuit board and a first support section; a meander line section connected to the first support section and a second support section and lying in a plane substantially parallel with and vertically above the circuit board; a second end connected to the second support section and a ground; and a single receiver for receiving the plurality of packets from the plurality of transmitting devices; wherein the receiver receives packets from the plurality of transmitting devices.

[0004d] In accordance with yet another aspect, a tire pressure monitoring device comprising: a sensor mounted inside a tire, the sensor configured for monitoring a tire condition and forming data packets containing the tire condition; and means for transmitting a signal containing the data packets; wherein the means for transmitting a data packet comprises: an antenna mounted on a planar circuit board and in communication with a transmitter for transmitting the plurality of packets, the antenna comprising: a first end connected to the planar circuit board and a first support section; a meander line section connected to the first support section and a second support section and lying in a plane parallel with and vertically above the circuit board; a second end connected to the second support section and an electrical ground wherein an attenuation of the signal through the tire is less than about 5 db.

Brief Description of the Drawings

[0005] In the accompanying drawings which are incorporated in and constitute a part of the specification, embodiments of the invention are illustrated, which, together with a general description of the invention given above, and the detailed description given below, serve to exemplify the embodiments of this invention.

[0006] **FIGURE 1** illustrates a schematic representation of a system, such as a tire pressure monitoring system, including the transmitting devices according to an example of the present invention.

[0007] **FIGURE 2** illustrates a transmitting device with an antenna according to an example of the present invention.

[0008] **FIGURE 3** illustrates a radiation plot comparing a prior art tire pressure sensor and a transmitting device according to the invention.

Detailed Description

[0009] With reference to **FIGURE 1**, a vehicle sensor system **10**, such as a tire pressure monitoring system, is illustrated on a vehicle **14**. The vehicle **14**, a tractor or a truck, generally has at least six wheel locations and at least six tires. The wheel locations include right front, right mid, right rear, left front, left mid and left rear. The right mid, right rear, left mid and left rear wheel locations may include an inner and an outer wheel location, if dual tires are placed at these locations. A sample tire placement is illustrated in Figure 1 with tire **12a** at the left front, tire **12b** at the right front, tire **12c** at the outer left mid, tire **12d** at the inner left mid, tire **12e** at the inner right mid, tire **12f** at the outer right mid, tire **12g** at the outer left rear, tire **12h** at the inner left rear, tire **12i** at the inner right rear, and tire **12j** at the outer right rear. The tires **12a, 12b, 12c, 12d, 12e, 12f, 12g, 12h, 12i, 12j** may be steel belted tires. Additional or fewer tires are contemplated. Alternatively, the vehicle **14** can be a trailer with at least four wheel locations.

[0010] Each tire in the vehicle sensor system **10** includes a transmitting device, illustrated by transmitting devices **16a, 16b, 16c, 16d, 16e, 16f, 16g, 16h, 16i, 16j**. The transmitting devices **16a, 16b, 16c, 16d, 16e, 16f, 16g, 16h, 16i, 16j** can be tire pressure sensors. The transmitting devices **16a, 16b, 16c, 16d, 16e, 16f, 16g, 16h, 16i, 16j** can be mounted on the rim inside the respective tires **12a, 12b, 12c, 12d, 12e, 12f, 12g, 12h, 12i, 12j**. The transmitting devices **16a, 16b, 16c, 16d, 16e, 16f, 16g, 16h, 16i, 16j** monitor tire characteristic information, such as the tire pressure, tire temperature, vehicle load and tire vibration.

[0011] Each transmitting device **16a, 16b, 16c, 16d, 16e, 16f, 16g, 16h, 16i, 16j** comprises a wireless transmitter that periodically transmit signals containing packets of data with the sensor information and a unique sensor identification code (ID) in a selected data transmission format. The format of the signals can be a standard or a proprietary radio frequency (RF) protocol. The transmitting device **16a, 16b, 16c, 16d, 16e, 16f, 16g, 16h,**

16i, 16j can also be configured to transmit signals upon rotation of the tire or when there is a tire pressure alert event.

[0012] The vehicle sensor system **10** includes a wireless receiver **24**. The wireless receiver **24** includes an antenna **26**, a processing unit **30** and a communication port **31**. The wireless receiver **24** wirelessly receives the signals containing the data packets in the selected data format from the transmitting devices **16a, 16b, 16c, 16d, 16e, 16f, 16g, 16h, 16i, 16j**. The wireless receiver **24** decodes the tire characteristic information from the selected data transmission format to a tire characteristic message capable of being communicated on a serial communication bus **20**. The format of the tire characteristic message may be a standard protocol, such as SAE J1939, or a proprietary protocol. The wireless receiver **24** is capable of communicating at least one tire characteristic message over the serial communication bus **20** via the communication port **31**. The tire characteristic message can include, but is not limited to, information such as the instantaneous tire pressure, the comparison of the tire pressure against a tire pressure limit, motion value, temperature and the unique sensor ID, for example.

[0013] For this particular vehicle sensor system **10** with transmitting devices **16a, 16b, 16c, 16d, 16e, 16f, 16g, 16h, 16i, 16j**, only one receiving antenna **26** is necessary as the transmitting devices **16a, 16b, 16c, 16d, 16e, 16f, 16g, 16h, 16i, 16j** suffer from less attenuation, as will be described. In one example, the attenuation of a signal containing the data packets from a transmitting device through a steel belted tire, for example, is less than 5dB.

[0014] The vehicle sensor system **10** includes a controller **22**. The controller **22** can be a stand-alone controller or include functionality for controlling the antilock braking system in addition to tire pressure monitoring. The controller **22** includes a communication port **28** for communicating with the serial communication bus **20** on the vehicle **10**. Controller **22** may communicate with other controllers on the vehicle **10** using the serial communication bus **20**. Alternatively, controller **22** may communicate wirelessly with other

controllers on the vehicle **10** or with an off-board communication device. The messages received and transmitted on the bus **20** can be in a standardized serial communication bus format, such as SAE J1939, or in a proprietary format. In an alternative embodiment, the wireless receiver **24** is integrated with the controller **22**.

[0015] In accordance with one example, a system for monitoring a condition on a vehicle comprises a plurality of transmitting devices, each of the plurality of transmitting devices configured to periodically transmit a plurality of signals containing data packets. The system includes a single receiving antenna for receiving the plurality of signals from the plurality of transmitting devices.

[0016] In **FIGURE 2**, an example of a transmitting device, such as transmitting device **16a**, according to the invention is shown. The transmitting device **16a** includes a planar circuit board **40**. The planar circuit board **40** is located in a plane **A**. The planar circuit board **40** includes an electrical ground.

[0017] A sensor **42** is mounted on the planar circuit board **40**. In one example, the sensor **42** is capable of detecting the pressure inside the tire **12a** of the vehicle **14**. In another example, the sensor **42** is capable of detecting the pressure and the temperature inside the tire **12a**. In another example, the sensor **42** may be a vibration sensor or an optical sensor. The sensor **42** includes a processor to form the captured tire information into data packets.

[0018] A transmitter **52** is mounted on the planar circuit board **40**. The transmitter **52** is in electrical communication with the sensor **42**. In one example, the transmitter **52** is integrated with the sensor **42**. The transmitter **52** is configured to convert the plurality of data packets from the sensor **42** into a carrier frequency and modulate the signal according to on-off keying (OOK) or frequency shift keying (FSK). The transmitter **52** periodically transmits the signal containing the plurality of data packets. The transmitter **52** is capable of transmitting signals periodically at a frequency of between about 300MHz and about 500MHz. In one example, the transmitter **52** is capable of transmitting at about 433MHz. Due to the design of this transmitting device **16a**, the transmitter **52** will transmit about five

data packets each period, wherein each period is about 500ms. The design of the present transmitting device **16a** reduces redundancy in data packet transmission that was required in the prior art sensors. This transmission data rate conserves power of the transmitting device **16a**. The transmitter **52** may use on-off keying (OOK) at a higher baud rate when transmitting to further conserve power of the transmitting device **16a**.

[0019] In addition, the sensor **42** may monitor the ambient temperature. When the measured ambient temperature is less than a temperature threshold, the sensor **42** switches the transmitter **52** to a lower transmission power, thereby lowering the current draw. In one example, the temperature threshold is about -20°C.

[0020] A power source **54** is mounted on the planar circuit board **40**. The power source **54** may be a battery. The power source **54** powers the sensor **42** and the transmitter **52**. In another example, the power source **54** can be mounted separately from the planar circuit board **40** while still being electrically connected to the sensor **42** and the transmitter **52**.

[0021] An antenna **50** is mounted on the planar circuit board **40** and spaced apart from the power source **54**. The antenna **50** is in electrical communication with the transmitter **52** for wirelessly transmitting the plurality of data packets. The antenna **50** comprises a first end **45** connected to transmitter **52** via the planar circuit board **40**. The first end **45** is connected to a first support section **46**. The first support section **46** is connected to a meander line section **44**. The meander line section **44** lies in a plane **B**, which is substantially parallel to plane **A** of the planar circuit board **40**. In one example, the meander line section **44** comprises three U-shaped sections. In another example, the meander line section **44** comprises two U-shaped sections. Additional or fewer U-shaped sections are contemplated. The length of the meander line section **44** is maximized while remaining within an outline profile of the planar circuit board **40**. The meander line section **44** is connected to a second support section **48**. The second support section **48** is connected to a second end **47**. In one example, the second end **47** is connected to the electrical ground on

the planar circuit board **40**. Grounding the antenna **50** at the second end **47** creates a loop antenna with horizontal polarization.

[0022] In one example, the first support section **46** and the second support section **48** raise the meander line section **44** a height **h1** above the surface of the planar circuit board **40**. In one example, the height **h1** is between about three (3) and five (5) centimeters. This height is less than the height of prior art tire pressure sensors that include a helical antenna. The height **h1** is approximately the same height as the power source **54**. The planar circuit board **40**, with all of the components mounted to the planar circuit board **40**, is fitted inside of a housing (not shown). Due to the configuration of the antenna **50**, the overall height of housing for the transmitting device **16a** can be minimized. The improved smaller housing makes the installation of the transmitting device **16a** into the tire **12a** easier and the transmitting device **16a** will be less prone to damage after installation. The raised meander line section **44** provides a desired radiation pattern along with a longer overall length of the antenna **50**.

[0023] In one example, the antenna **50** is constructed of a metallic material. The metal material may be steel, copper or phosphor bronze. The metallic material may be plated.

[0024] The circuit board **40** may be coated with a thermoplastic elastomer coating for protection against environmental elements. Alternatively, the circuit board **40** may be installed in the housing and the housing filled with an epoxy compound for protection. Any change to a coating material or to the depth of epoxy compound in the housing affects the tuning of the antenna in the prior art tire pressure sensors. The prior art transmitting device may require several steps during manufacturing to tune the antenna. However, the design of the present antenna **50** as a loop antenna with a raised meandering portion **44** makes the transmitting device **16a** less susceptible to detuning as impedance changes caused by the coating or compound materials are mitigated.

[0025] Due to the configuration of the antenna **50** as a loop antenna with one end ground, the antenna **50** is horizontally polarized. The raised meander line section **44** facilitates a focused radiation pattern and longer antenna length. Any radiation in the vertical direction is substantially decreased, thereby increasing the power in the horizontal direction. In one example, the transmitting device **16a** is oriented inside the tire **12a** in such a manner than the antenna **50** is substantially perpendicular to the sidewall of the tire **12a**. In this manner, the antenna **50** can be in an orientation other than substantially parallel to the circuit board **40** while still being effectively horizontally polarized.

[0026] Transmitting devices **16b, 16c, 16d, 16e, 16f, 16g, 16h, 16i, 16j** are configured similar to transmitting device **16a** as shown in Figure 2.

[0027] Therefore, one example of a transmitting device comprises a planar circuit board; a sensor mounted on the planar circuit board configured to sense a vehicle condition and form a plurality of data packets, the data packets including the vehicle condition; a transmitter mounted on the planar circuit board and in electrical communication with the sensor, the transmitter configured to periodically wirelessly transmit signals containing the plurality of packets; and an antenna mounted on the planar circuit board and in communication with the transmitter for transmitting the signals. The antenna comprises a first end connected to the planar circuit board and a first support section; a meander line section connected to the first support section and a second support section and lying in a plane substantially parallel with the circuit board; a second end connected to the second support section and an electrical ground.

[0028] In **FIGURE 3**, an example of a radiation plot **70** as measured from the outer right mid axle tire **12f** on the vehicle **14** is shown. The radiation plot **70** displays the received power levels of a prior art tire pressure sensor with a helical antenna and a transmitting device with an antenna according to this invention, such as transmitting device **16f**. The received power levels are measured at a receiving antenna, such as receiving antenna **26**. The receiving antenna **26** may have a sensitivity limit of -115dBm, as shown at

the center of the plot **70**, for example. For comparison purposes, the prior art tire pressure sensor and the transmitting device **16f** are mounted inside the tire and transmitting at a frequency of about 433 MHz. Both the prior art tire pressure sensor and the transmitting device **16f** are transmitting at the same power levels of 0 dBm. The outermost line **71** of the plot **70** shows the degrees of rotation of the tire at the point at which the received power level was measured. The prior art tire pressure sensor is shown as line **72** inside the plot and an example of the inventive transmitting device **16f** as line **76**. Line **74** shows an average limit required to be considered acceptable signal strength at the receiving antenna **26**. In this instance, 20dB gain over the -115dBm antenna limit in all directions is considered an acceptable range such that the data packets would be reliably received by the receiving antenna **26**.

[0029] Line **72** shows the received power level of a prior art tire pressure sensor. For the prior art tire pressure sensor, the transmission of the data packets does not reach the average limit line **74** in some orientations of the tire. There can be as much as 25dB loss of the signal containing the data packets due to the orientation and type of antenna of the prior art sensor and the resulting attenuation of the signal through the steel belted tire **12a**. Therefore, the data packets may not be reliably received at the receiving antenna **26** when the tire **12f** is at an orientation of 180°, for example. Because of this attenuation, more than one receiving antenna will need to be located at various locations on the vehicle so that the data packets can be reliably received.

[0030] Line **76** shows the received power levels of a transmitting device **16f**. As can be seen in the plot **70**, the received power levels of the transmitting device **16f** have a margin of about 20 dB over the average limit line **74** in most tire orientations. Even at the 180° orientation, the received power level illustrated by line **76** of the transmitting device **16f** meets the average limit line **74**. In this manner, the data packets from the transmitting device **16f** can be reliably received by the receiving antenna **26** no matter the orientation of the tire **12f** with respect to the receiving antenna **26**.

[0031] With the present inventive transmitting devices **16a, 16b, 16c, 16d, 16e, 16f, 16g, 16h, 16i, 16j**, data packets can be reliably received at the single antenna **26** no matter the orientation of the tires **12a, 12b, 12c, 12d, 12e, 12f, 12g, 12h, 12i, 12j** or the distance of the tires **12a, 12b, 12c, 12d, 12e, 12f, 12g, 12h, 12i, 12j** from the antenna **26**. No increase in power transmission requirements at the transmitting devices **16a, 16b, 16c, 16d, 16e, 16f, 16g, 16h, 16i, 16j** is required to achieve reliable reception of the data packets, thereby increasing the life of the transmitting device **16a, 16b, 16c, 16d, 16e, 16f, 16g, 16h, 16i, 16j**. In addition, the number of data packets transmitted can be reduced because of the increase reliability of the data packets reaching the antenna **26**.

[0032] In a prior art sensor, when a vehicle is stationary, the tire may be at a rotation angle where the signal is significantly attenuated, for example line **72** of Figure 3 at the 180° tire orientation. The signal may not be received by the receiving antenna. The configuration of present antenna **50** allows for immediate readings of vehicle sensor information upon power up of the vehicle sensor system **10** because the angle of orientation of the tire does not affect the received power level of the signals received from the transmitting devices. No matter the orientation angle of the tire, the signal is great enough to be received at the receiving antenna, thereby making stationary vehicle monitoring much more reliable.

[0033] While the present invention has been illustrated by the description of embodiments thereof, and while the embodiments have been described in considerable detail, it is not the intention of the applicants to restrict or in any way limit the scope of the appended claims to such detail. Additional advantages and modifications will readily appear to those skilled in the art. Therefore, the invention, in its broader aspects, is not limited to the specific details, the representative apparatus, and illustrative examples shown and described. Accordingly, departures may be made from such details without departing from the spirit or scope of the applicant's general inventive concept.

We claim:

1. A transmitting device comprising:
 - a planar circuit board;
 - a sensor mounted on the planar circuit board configured to sense a vehicle condition and form a plurality of data packets, the data packets including the vehicle condition;
 - a transmitter mounted on the planar circuit board and in electrical communication with the sensor, the transmitter configured to periodically wirelessly transmit signals containing the plurality of data packets; and
 - an antenna mounted on the planar circuit board and in electrical communication with the transmitter for transmitting signals containing the plurality of data packets, the antenna comprising:
 - a first end connected to the planar circuit board and a first support section;
 - a meander line section connected to the first support section and a second support section and lying in a plane substantially parallel with and vertically above the circuit board;
 - a second end connected to the second support section and an electrical ground.
2. The transmitting device as in claim 1, wherein the meander line section further comprises three U-shaped sections.
3. The transmitting device as in claim 1, wherein the first and second support sections raise the meander line section of a single band antenna between about three centimeters and five centimeters from a surface of the planar circuit board.
4. The transmitting device as in claim 1, wherein the antenna comprises a plated metal.
5. The transmitting device as in claim 1, wherein the antenna is horizontally polarized.
6. The transmitting device as in claim 1, wherein the planar circuit board is coated with a material and impedance of the antenna remains substantially equal to the impedance of the antenna without coating of the antenna.
7. The transmitting device as in claim 1, wherein the transmitter is capable of transmitting about five data packets each period, wherein each period is about five hundred milliseconds.
8. The transmitting device as in claim 1, wherein the sensor is configured for detecting a pressure of a pneumatic tire of a vehicle.
9. The transmitting device as in claim 1, wherein the transmitting devices transmits a signal at a frequency of between about 300 MHz and 500 MHz.
10. A transmitting device comprising:
 - a planar circuit board;

a sensor mounted on the planar circuit board configured to sense a vehicle condition and form a plurality of data packets, the data packets including the vehicle condition;

a transmitter mounted on the planar circuit board and in electrical communication with the sensor, the transmitter configured to periodically wirelessly transmit signals containing the plurality of data packets;

an antenna mounted on the planar circuit board and in electrical communication with the transmitter for transmitting signals containing the plurality of data packets, the antenna comprising:

a first end connected to the planar circuit board and a first support section;

a meander line section connected to the first support section and a second support section and lying in a plane substantially parallel with the circuit board;

a second end connected to the second support section and an electrical ground; and

a control circuit in communication with the transmitter and the sensor, wherein the sensor is configured for detecting an ambient temperature and the control circuit is capable of lowering a transmission power level in response to a temperature less than a temperature threshold.

11. The transmitting device as in claim 10, wherein the temperature threshold is about -20 C.

12. A system for monitoring a condition on a vehicle comprising:

a plurality of transmitting devices; wherein each of the plurality of transmitting devices comprises:

a planar circuit board;

a sensor mounted on the planar circuit board configured to sense a vehicle condition and form a plurality of data packets, the data packets including the vehicle condition;

a transmitter mounted on the planar circuit board and in communication with the sensor, the transmitter configured to periodically wirelessly transmit signals containing the plurality of data packets; and

an antenna mounted on the planar circuit board and in communication with the transmitter for transmitting the signals containing the plurality of data packets, the antenna comprising:

a first end connected to the planar circuit board and a first support section;

a meander line section connected to the first support section and a second support section and lying in a plane substantially parallel with and vertically above the circuit board;

a second end connected to the second support section and a ground; and

a single receiver for receiving the plurality of packets from the plurality of transmitting devices; wherein the receiver receives packets from the plurality of transmitting devices.

13. The system as in claim 12, wherein the transmitting devices are located inside a pressurized portion of a plurality of tires of the vehicle.

14. The system as in claim 13, wherein the transmitting devices are mounted such that the antennas are substantially perpendicular to sidewalls of the tires.

15. A tire pressure monitoring device comprising:

a sensor mounted inside a tire, the sensor configured for monitoring a tire condition and forming data packets containing the tire condition; and

means for transmitting a signal containing the data packets; wherein the means for transmitting a data packet comprises:

an antenna mounted on a planar circuit board and in communication with a transmitter for transmitting the plurality of packets, the antenna comprising:

a first end connected to the planar circuit board and a first support section;

a meander line section connected to the first support section and a second support section and lying in a plane parallel with and vertically above the circuit board;

a second end connected to the second support section and an electrical ground wherein an attenuation of the signal through the tire is less than about 5 db.

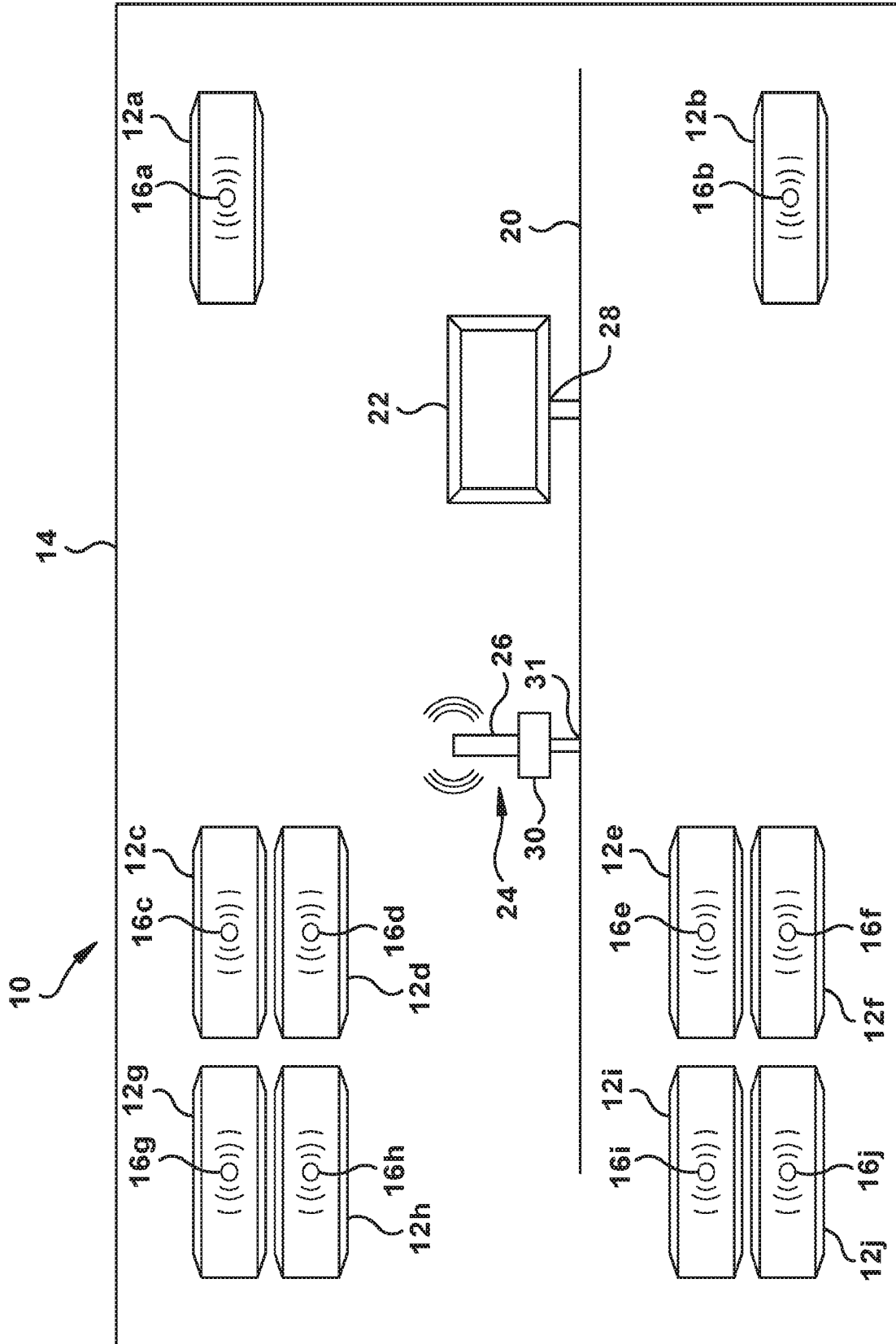

Figure 1

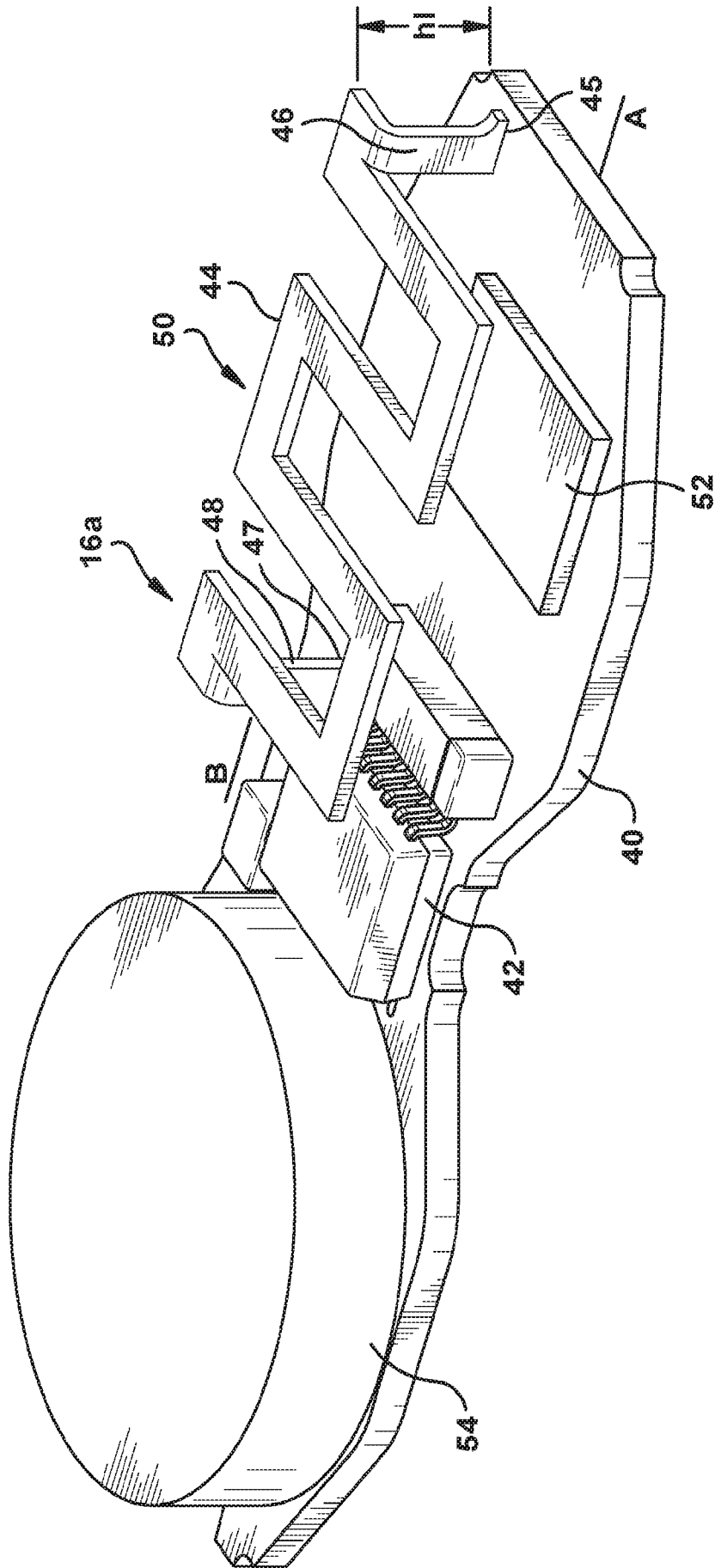

Figure 2

