



(86) Date de dépôt PCT/PCT Filing Date: 2008/04/30
 (87) Date publication PCT/PCT Publication Date: 2008/11/13
 (85) Entrée phase nationale/National Entry: 2009/11/05
 (86) N° demande PCT/PCT Application No.: EP 2008/055389
 (87) N° publication PCT/PCT Publication No.: 2008/135518
 (30) Priorité/Priority: 2007/05/05 (DE20 2007 006 451.9)

(51) Cl.Int./Int.Cl. *B62M 9/12* (2006.01),
B62K 25/02 (2006.01)
 (71) Demandeur/Applicant:
KLIBER, JOCHEN, DE
 (72) Inventeur/Inventor:
GRAETZ, MICHAEL, DE
 (74) Agent: MOFFAT & CO.

(54) Titre : PATTE DE DERAILLEUR AVEC AIDE A L'INSTALLATION
 (54) Title: DERAILLEUR HANGER WITH INSERTION AID

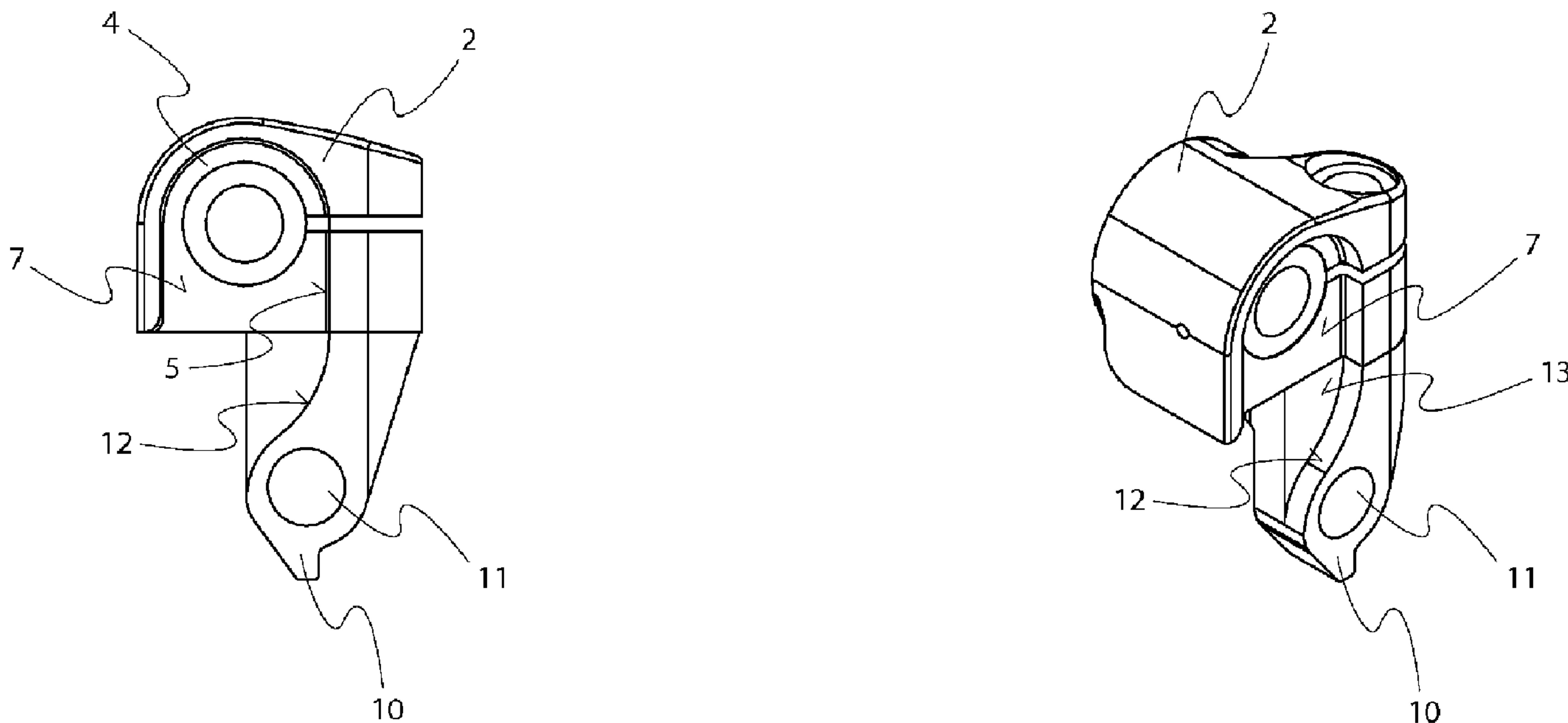

Fig. 2

(57) Abrégé/Abstract:

The invention relates to a derailleur hanger for a bicycle comprising an insertion aid for inserting the wheel hub between the dropout ends of a bracket or a frame. A derailleur hanger (10) according to the invention for a bicycle, comprising first and/or second recesses (4) on a first dropout end (1) and/or on a second dropout end (2) for accommodating the corresponding ends of a wheel hub is characterized in that the derailleur hanger (10) is designed such that the course of one lateral surface (5) of the recess (4) is substantially consistently sustained by a first guide surface (12) of the derailleur hanger (10).

Abstract

The invention relates to a derailleur hanger for a bicycle having an insertion aid for inserting the wheel hub between the dropouts of a fork or frame. A derailleur hanger (10) for a bicycle according to the invention having, on a first dropout (1) and/or on a second dropout (2), first and second recesses (3, 4), respectively, for receiving the corresponding ends (31, 32) of a wheel hub (30) is characterized in that the derailleur hanger (10) is configured such that the shape of a lateral surface (5) of the recess (4) is substantially steadily continued by a first guide surface (12) of the derailleur hanger (10).

Official ref.:
Our ref.: P11510CAPC

- 1 -

Derailleur hanger with insertion aid

The present invention relates to a derailleur hanger for a bicycle. In particular, the present invention relates to a bicycle derailleur hanger having an insertion aid for inserting the wheel hub between the dropouts of a fork or frame.

When through-axle systems are used for mounting wheels, in the assembled state, both sides of the wheel hub with the through-axle extending through it are received in downwardly open, U-shaped recesses provided at the dropouts. In this way the wheel hub is easily placed in the position required for assembly. To ensure that the wheel hub fits with as little play as possible, the distance between the dropouts is adapted to match the length of the wheel hub, with only a slightly greater distance provided between the dropouts to ensure that the wheel hub fits with as little play as possible.

When inserting the wheel into the fork or frame, this often results in the problem that the wheel hub may be tilted between the dropouts, which makes mounting the wheel more difficult. Moreover, under usual circumstances, the rear wheel of a bicycle is inserted against the pull of the chain tensioning device on the derailleur, because the chain has to be put over the cogset before both ends of the wheel hub are pushed into the recesses of the dropouts intended for this purpose. This sometimes makes mounting a wheel substantially more difficult, especially if the wheel is mounted using a through-axle system.

Therefore, it is an object of the present invention to provide a device which overcomes the disadvantages of the

Official ref.:
Our ref.: P11510CAPC

-2-

prior art and which in particular permits, by simple means, placing a wheel into the position intended for mounting it - against the pull of the chain tensioning device, if necessary - and preferably to provide a solution that is easy to manufacture and has reduced weight.

This and other objects are achieved by a derailleur hanger for a bicycle according to independent Claim 1. Preferred embodiments are the subject of the dependent claims.

Accordingly, a derailleur hanger for a bicycle having first and second recesses, respectively, on a first dropout and/or a second dropout, for receiving the corresponding ends of a wheel hub, includes a first guide surface which is a substantially steady continuation of the side surface, i.e. the lateral limiting surface of the corresponding recess.

In this way, when mounting the wheel, the derailleur hanger of the present invention permits moving the respective end of the wheel hub along the first guide surface of the derailleur hanger so that the wheel hub automatically advances to its mounting position within the recesses of the two dropouts. By arranging a suitably designed first guide surface on the derailleur hanger, a solution is provided that is easy to manufacture and, in particular, has reduced weight.

In a particularly preferred embodiment of the present invention, the first and/or second recess additionally includes a lateral support surface against which, in the assembled state, the corresponding end of the wheel hub is supported because the two dropouts are braced against each other. In this case, the derailleur hanger is preferably configured such that the shape of the support surface of the recess of the dropout is substantially steadily continued

Official ref.:
Our ref.: P11510CAPC

- 3 -

along a second guide surface of the derailleur hanger.

In this way, when the wheel hub is positioned against the first and second guide surfaces of the derailleur hanger, the hub is guided so as to successfully avoid wedging of the hub and/or shifting due to the tensional forces from the chain tensioning device, for example, that act on one side of the hub. In that context, the first and second guide surfaces limit the path of the hub in two spatial directions so that even in difficult conditions it can be safely and quickly positioned in the recesses of the dropouts intended for this purpose.

Preferably the derailleur hanger of the present invention has a first hole for receiving a first fastening bolt for a derailleur, the first hole extending substantially in parallel with the central axis of the wheel hub.

In a particularly preferred embodiment of the present invention, the derailleur hanger is configured as a part separate from the dropout, which part is fixed to the dropout by at least a second fastening bolt in the assembled state. By releasing the fastening bolt, the derailleur hanger can be replaced with a similar derailleur hanger, e.g. if it has been damaged.

Particularly preferably, the second fastening bolt extends substantially perpendicular to the central axis of the hub, in which case the second fastening bolt may also be used for fastening or bracing other parts to the dropout if necessary. Preferably the derailleur hanger has a threaded hole which the second fastening bolt can directly be screwed into, whereby the derailleur hanger can be securely attached to the corresponding dropout.

Official ref.:
Our ref.: P11510CAPC

- 4 -

To further improve attachment of the derailleur hanger to the dropout, and particularly preferred to avoid rotation of the derailleur hanger about the axis of the second fastening bolt, both during mounting and while the bicycle is in use, there is provided on the derailleur hanger an anti-rotation element in the form of a pin which engages with a corresponding hole located on the dropout.

Other features of the present invention are apparent from the following detailed description in combination with the claims and the figures, in which

Fig. 1 shows a wheel hub mounted between two dropouts;

Fig. 2 shows a derailleur hanger of the present invention with an insertion aid according to one embodiment of the invention in the mounted state;

Fig. 3 shows a derailleur hanger of the present invention with an insertion aid according to one embodiment of the invention in the unmounted state.

In the following description of the figures, the same reference numerals refer to the same elements, or elements that have similar functions, in different figures.

Fig. 1 shows a wheel hub mounted using a through-axle system for attachment of the wheel, as is also known from the prior art. The first end 31 of the wheel hub 30 is received in a first recess 3 of the first dropout 1, and its second end 32 opposite the first end is received in a second recess 4 of the second dropout 2.

By screwing in and tightening the through axle as shown in Fig. 1, the dropouts 1, 2 are slightly pulled together, so that the wheel hub 30 positioned between the dropouts is

Official ref.:
Our ref.: P11510CAPC

- 5 -

braced between the support surfaces 6 and 7.

To facilitate the insertion of the wheel hub into the recesses 3, 4, a derailleur hanger 10 of the present invention, as shown in Figure 2, has a guide surface 12 the shape of which substantially steadily continues into a lateral surface 5 of the recess 4 of the second dropout 2. The guide surface 12 limits the freedom of movement of the wheel hub in the plane of the area of the wheel to the effect that moving the end 32 of the hub 30 along the guide surface 12 automatically results in the end sliding into the recess 4.

The same is true for the second guide surface 13 provided on the derailleur hanger 10, which guide surface is a substantially steady continuation of the support surface 7 of the dropout 2. The second guide surface 13, however, limits the freedom of movement of the wheel hub along the wheel's axis, so that the wheel hub can be inserted into the recesses of the dropouts intended for this purpose, even against the sometimes substantial pull of the chain tensioning device of the derailleur.

Figures 2 and 3 show the design of a derailleur hanger 10 of the present invention which is configured separate from the dropout 2, with the second fastening bolt 20 positioned substantially perpendicular to the central axis of the wheel hub.

In the embodiment of Fig. 3, there is a pin 16 provided on the derailleur hanger 10, which pin engages with a corresponding hole on the dropout 2 and results in improved stability of the mechanical connection between the derailleur hanger 10 and the dropout 2 after insertion and tightening of

Official ref.:
Our ref.: P11510CAPC

-6-

the fastening bolt 20. In particular, the pin 16 serves to secure the derailleur hanger 10 against twisting relative to the dropout 2 when tightening the fastening bolt 20, ensuring in all cases that the first and second guide surfaces of the derailleur hanger continue substantially steadily into the lateral surface 5 and the support surface 7 of the recess 4.

Claims

1. A derailleur hanger (10) for a bicycle having first and second recesses (3, 4), respectively, on a first dropout (1) and/or on a second dropout (2), for receiving the corresponding ends (31, 32) of a wheel hub (30),

characterized in that

the derailleur hanger (10) is configured such that the shape of a lateral surface (5) of the recess (4) is substantially steadily continued by a first guide surface (12) of the derailleur hanger (10).

2. The derailleur hanger (10) for a bicycle according to claim 1,

characterized in that

the first and/or second recess (3, 4) has a support surface (6, 4) against which the corresponding end (31, 32) of the wheel hub (30) is supported in the assembled state, and

the derailleur hanger (10) is configured such that the shape of the support surface (7) of the recess (4) is substantially steadily continued by a second guide surface (13) of the derailleur hanger (10).

3. The derailleur hanger (10) for a bicycle according to claim 1 or 2,

Official ref.:
Our ref.: P11510CAPC

- 8 -

characterized in that

provided on the derailleur hanger (10) is at least a first hole (11) for receiving a first fastening bolt for a derailleur.

4. The derailleur hanger (10) for a bicycle according to any of claims 1 to 3,

characterized in that

the derailleur hanger (10) is configured as a part separate from the dropout and is releasably attached to the dropout by at least a second fastening bolt (20) in the assembled state.

5. The derailleur hanger (10) for a bicycle according to claim 4,

characterized in that

attachment by means of the second fastening bolt (20) is in a direction substantially perpendicular to the wheel axle (8).

6. The derailleur hanger (10) for a bicycle according to claim 4 or 5,

characterized in that

the derailleur hanger (10) has a threaded hole (15) into which the second fastening bolt (20) is screwed.

Official ref.:
Our ref.: P11510CAPC

- 9 -

7. The derailleur hanger (10) for a bicycle according to any of claims 4 to 6,

characterized in that

provided on the derailleur hanger (10) is a pin (16) which in the assembled state engages with a corresponding hole.

8. The derailleur hanger (10) for a bicycle according to any of claims 4 to 7,

characterized in that

provided on the derailleur hanger (10) is an anti-rotation element which in the assembled state prevents twisting of the derailleur hanger (10) relative to the dropout.

9. The derailleur hanger (10) for a bicycle according to any of claims 1 to 8,

characterized in that

the derailleur hanger is made of a material selected from a group comprising metals and metal alloys, particularly light metals, preferably aluminum and aluminum titanium alloys, and carbon fiber materials, plastics and particularly fiber-reinforced plastics, and composites of these materials and combinations thereof.

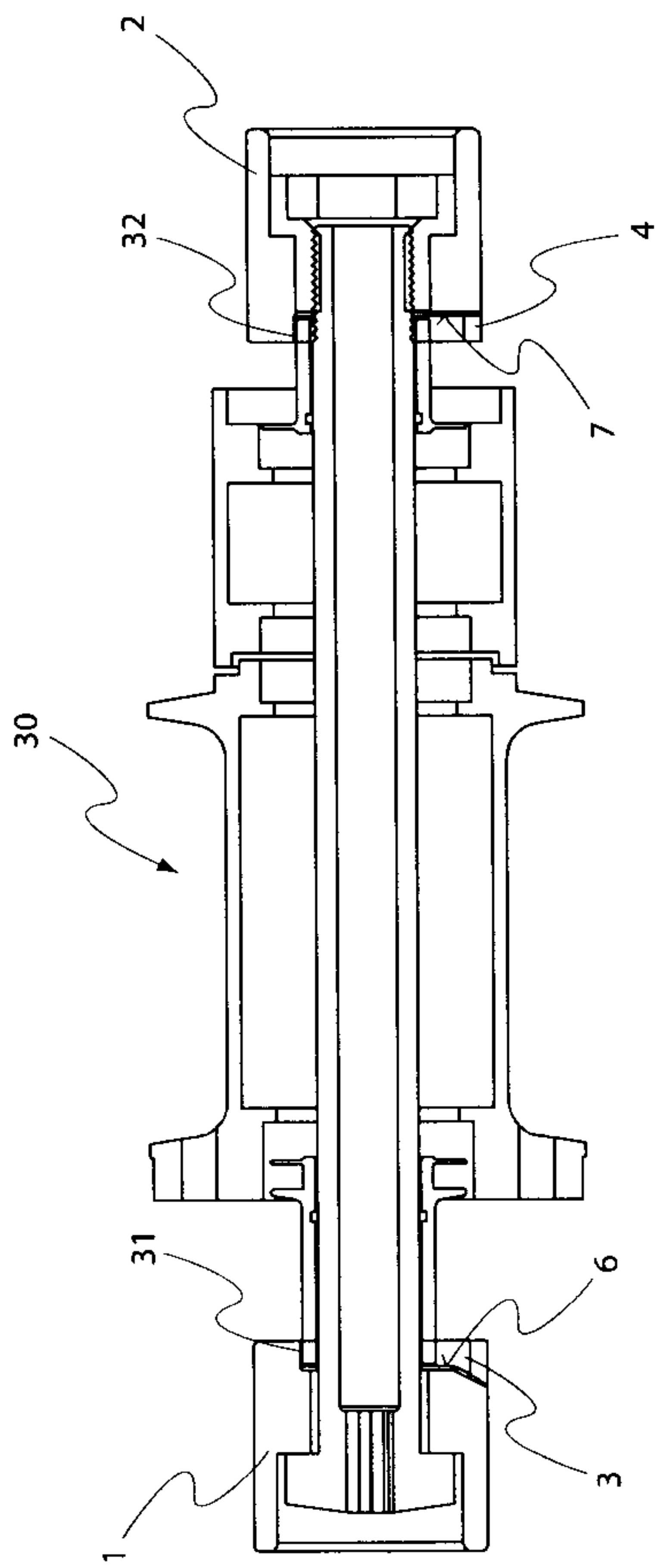

Fig. 1

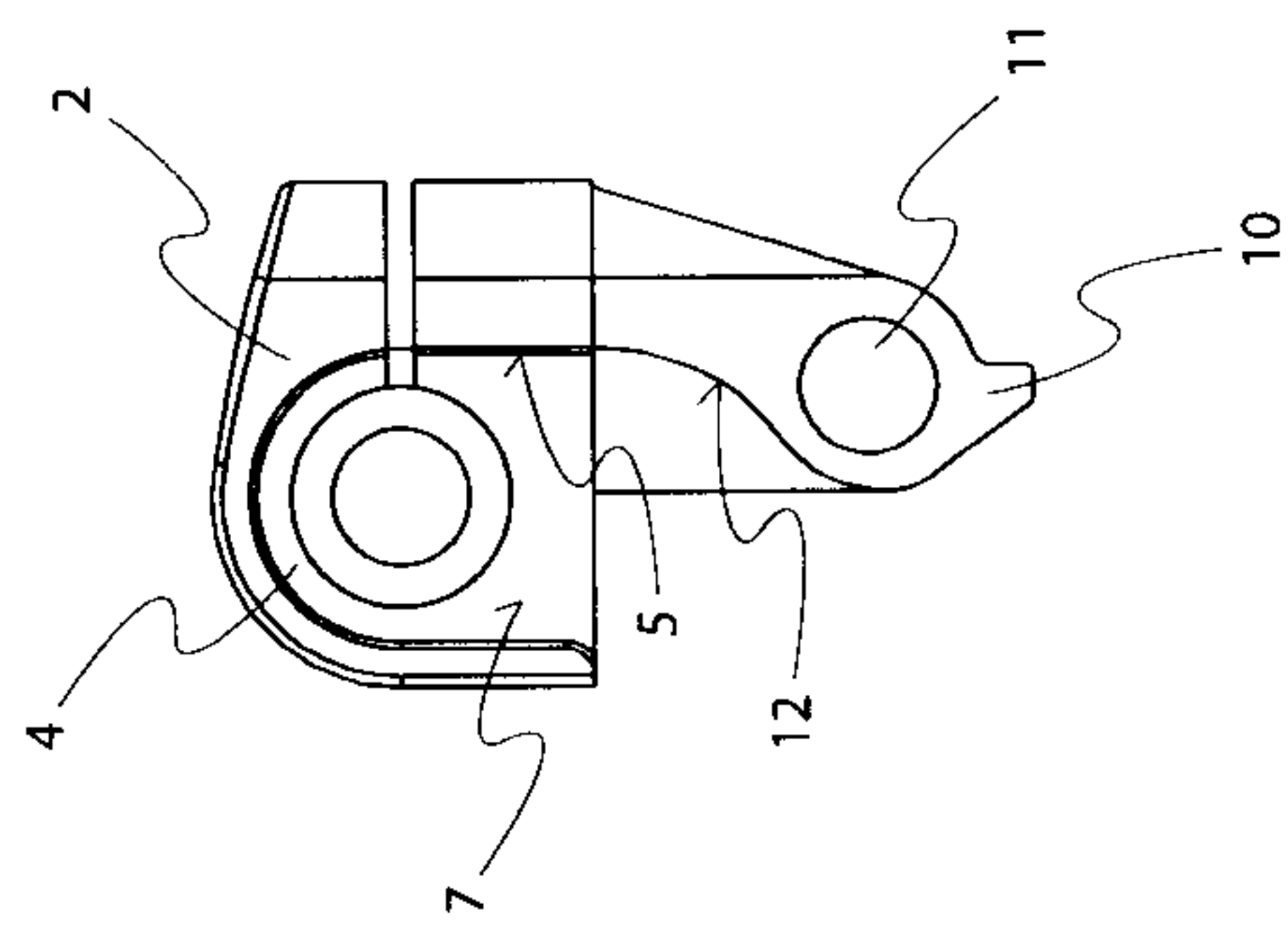
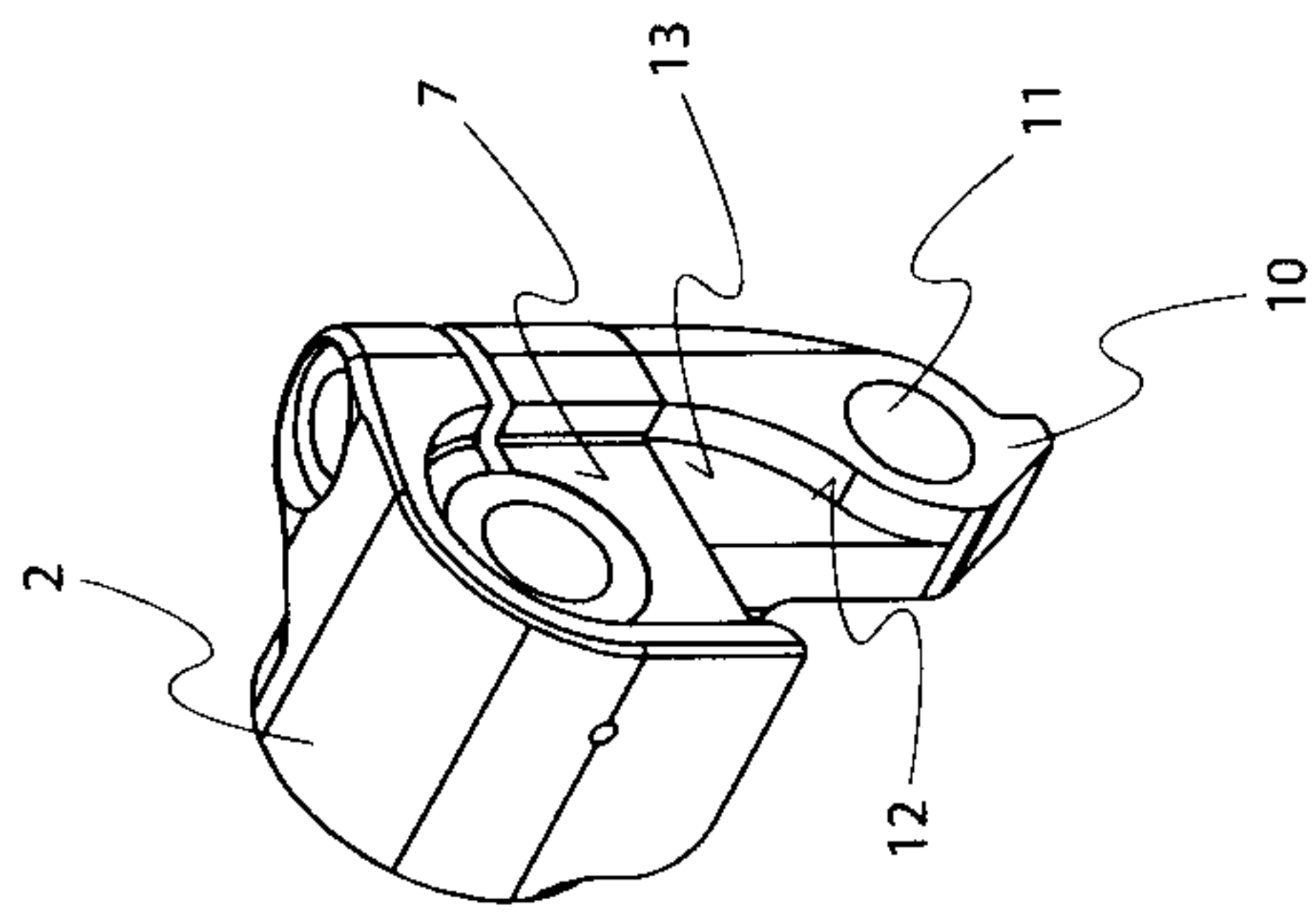

Fig. 2

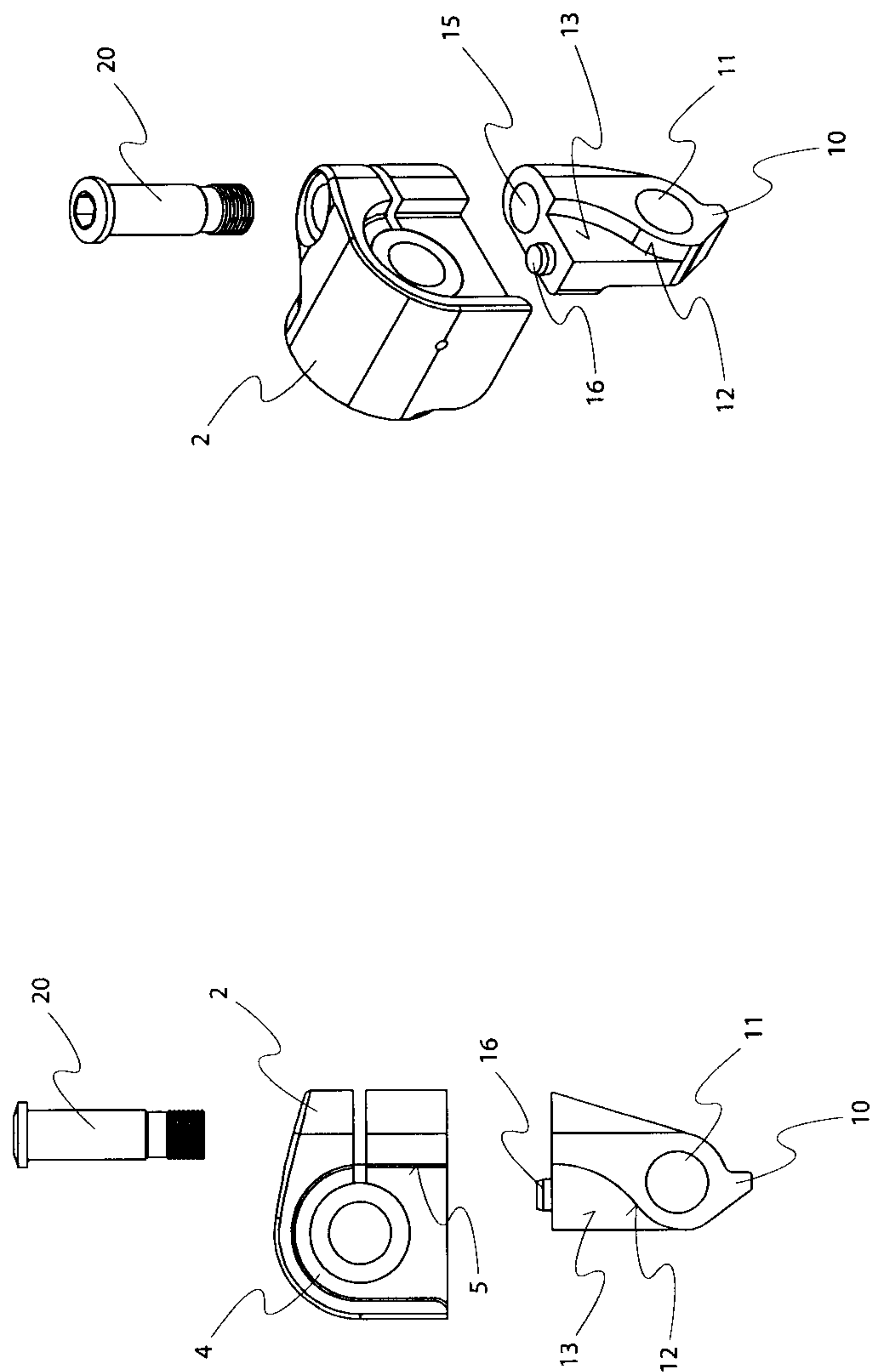

Fig. 3

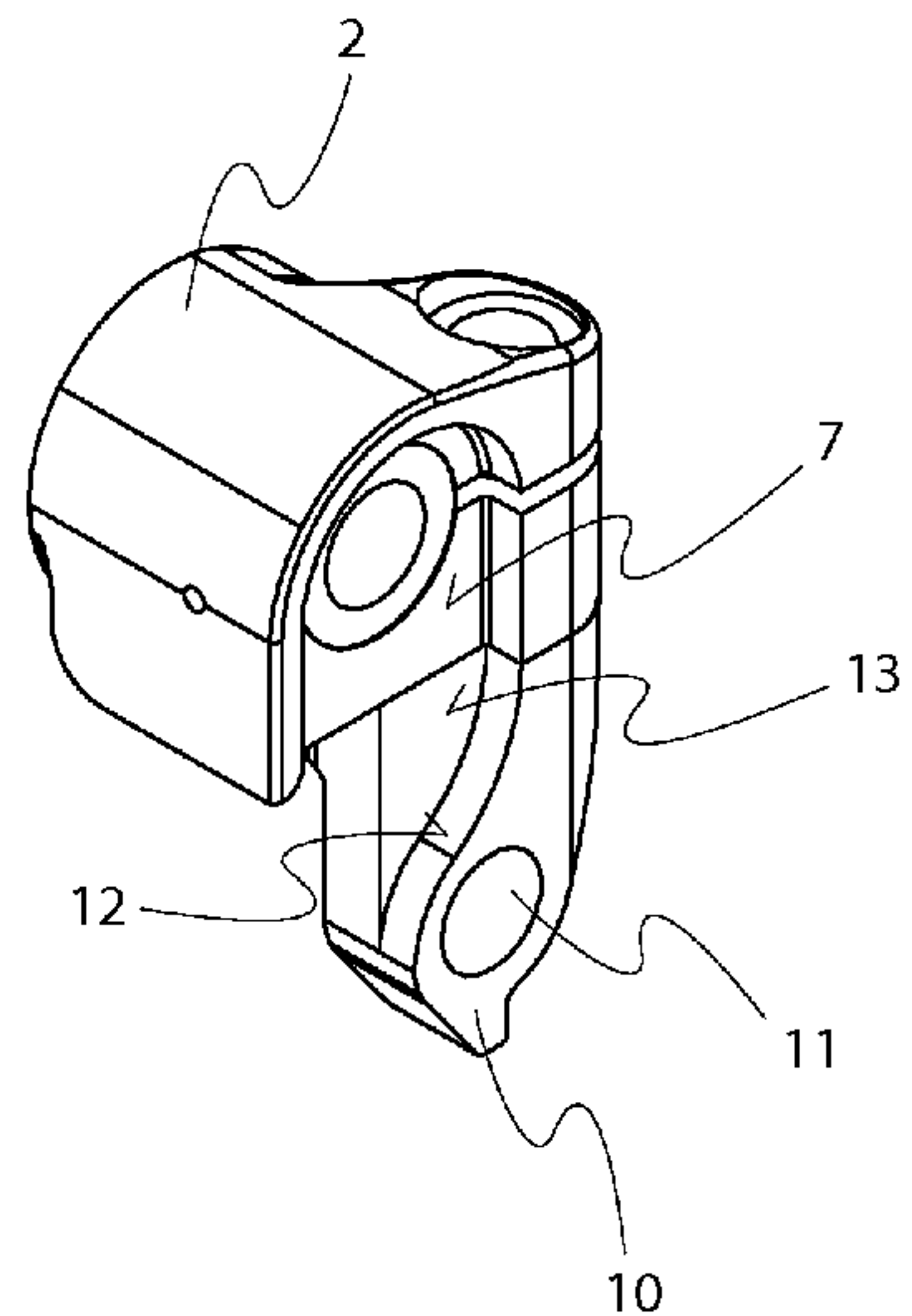
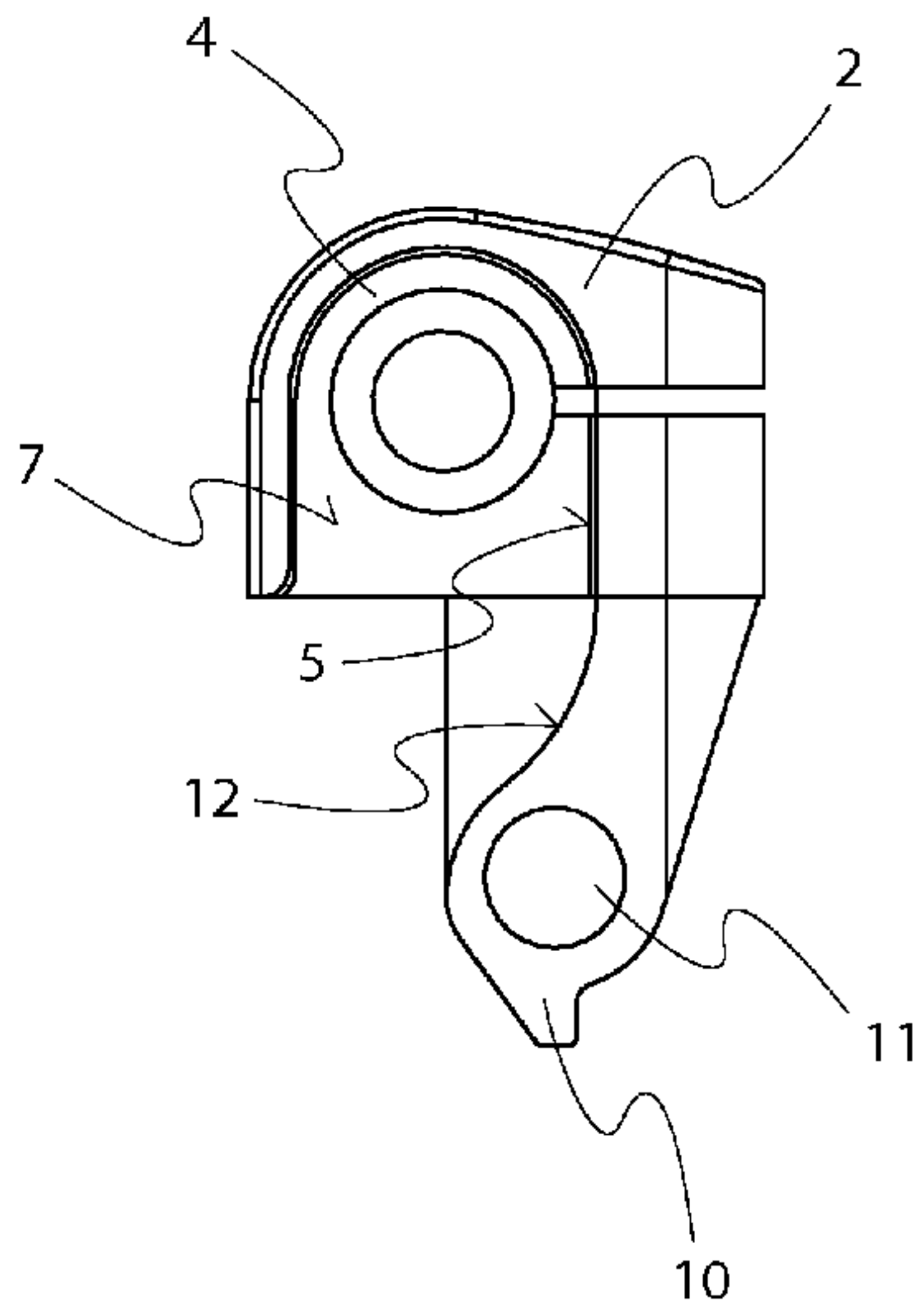

Fig. 2