

(19) World Intellectual Property Organization  
International Bureau



(43) International Publication Date  
4 April 2002 (04.04.2002)

PCT

(10) International Publication Number  
**WO 02/27862 A1**

(51) International Patent Classification<sup>7</sup>: **H01Q 1/24**, 7/00

Lane, Morgan Hill, CA 95037 (US). **JOHNSON, Greg**;  
1931 Seascape Boulevard, Aptos, CA 95003 (US).

(21) International Application Number: PCT/US01/30234

(22) International Filing Date:

26 September 2001 (26.09.2001)

(74) Agent: **KLOS, John, F.**; Larkin, Hoffman, Daly & Lindgren, Ltd., 7900 Xerxes Avenue South #1500, Bloomington, MN 55431 (US).

(25) Filing Language:

English

(81) Designated States (*national*): CN, JP, KR.

(26) Publication Language:

English

(84) Designated States (*regional*): European patent (AT, BE, CH, CY, DE, DK, ES, FI, FR, GB, GR, IE, IT, LU, MC, NL, PT, SE, TR).

(30) Priority Data:

09/675,774 27 September 2000 (27.09.2000) US  
09/844,312 27 April 2001 (27.04.2001) US

Published:

— with international search report

(71) Applicant: **RANGESTAR WIRELESS, INC.** [US/US];  
Suite 100, 9565 Soquel Drive, Aptos, CA 95003 (US).

For two-letter codes and other abbreviations, refer to the "Guidance Notes on Codes and Abbreviations" appearing at the beginning of each regular issue of the PCT Gazette.

(72) Inventors: **HILL, Robert**; 8711 Lilac Court, Salinas, CA 93907 (US). **COMMENS, Matthew, H.**; 551 Creekside

(54) Title: OMNI DIRECTIONAL ANTENNA WITH MULTIPLE POLARIZATIONS

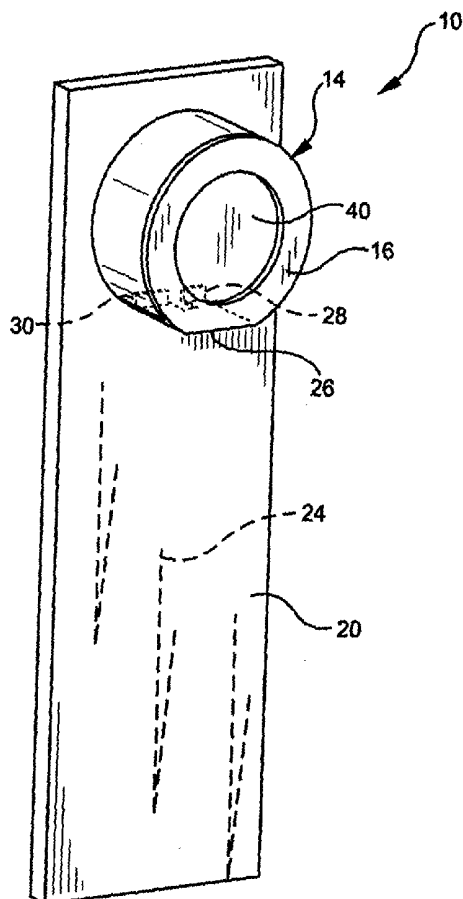

(57) Abstract: An omni-directional antenna assembly is provided for wireless communications device (10) requiring multiple polarization characteristics. An antenna assembly for a communication device operation at a predetermined wavelength and having a transceiver circuit including a signal output and a ground plane, the antenna assembly including a conductive planar element (14) disposed away from the ground plane (20) and a conductive leg member (26) coupled to the planar element proximate a perimeter, the planar element being disposed a distance away from the ground plane of the communication device to define a region capable of receiving one or more components (82) associated with the wireless communication device.



WO 02/27862 A1

## Omni Directional Antenna with Multiple Polarizations

5

### Field of the Invention

This invention relates generally to antenna structures for wireless communications devices, and more particularly to compact, high efficiency, electrically small loop antennas for use in conjunction with portable wireless communication devices.

10

### Background of the Invention

The physical size of modern compact communication devices often is dictated by the size of the antenna needed to make them function effectively. To avoid devices that are too large, pagers and other devices have made use of electrically small rectangular loop (1/10 wavelength). However, these small antennae tend to be inefficient as a result of their very low radiation resistance and comparatively high resistive loss. Likewise, as a result of their high Q they tend to be sensitive to their physical environment.

15

Yet another consideration and challenge of designing modern wireless communications devices is the efficiency of packaging the necessary components within an increasing smaller physical package. As the overall size of wireless devices has continued to decrease, a particularly difficult challenge to those skilled in the relevant arts has been the efficient placement of components, such as batteries, antenna structures, RF signal reception and transmission circuits, and other digital and/or analog devices or module, within the overall device package. Especially important has been the placement of antenna structures and assemblies relative to the RF signal generating components or modules. Those skilled in

20

25

the relevant arts recognize the difficulties in preventing electromagnetic coupling between these components.

To overcome the disadvantages of electrically small loop antennas, there is a continuing need for antennas small in physical dimension; having relatively high efficiency; 5 capable of being placed in close proximity to associated electronic circuits without adversely effecting performance; easy to manufacture using standard, low-cost components; and capable of having radiation patterns altered to support different applications.

For some wireless communications devices, an antenna assembly may be located remotely from the electronic device or devices it is serving. Remote location of the antenna 10 assembly relative the associated wireless device may minimize coupling of RF energy into digital or other circuitry from the strong fields around the antenna or for the antenna to have access to signals. GPS receivers, and BLUETOOTH® or other types of UHF and microwave digital transceivers, particularly those having the antenna integrated on or within the device, often benefit by having the antenna assembly remotely disposed relative to the RF signal 15 generating/ receiving components.

One limitation associated with a remote antenna is that power is lost through the transmission line connecting the antenna assembly to the electronics. Obviously, this is undesirable as it degrades the performance of the system by increasing the noise and reducing the transmit power. A decrease in important antenna parameters, such as gain, results from 20 power loss in the transmission line. Signal reception is also negatively impacted by transmission line losses.

Also known are circular polarization antenna structures or systems for reception of left hand and right hand polarized signals. Circular polarization is typical of satellite systems, such as the Global Positioning System (GPS). This field is in rapid expansion due to the vast 25 range of possible applications and the relative low cost of implementing these systems.

The fixed and mobile land devices associated with such systems have required more specialized antennas designed to perform specific functions effectively. Two types of antennas have to date been used in circular polarization communication and navigation systems on mobile devices: the first is the “helix” or helicoidal antenna, while the second is  
5 known as the “patch” antenna.

In helicoidal antennas, circular polarization is obtained by exciting a progressive wave on a helicoidal wire; the direction of the circular polarization (left or right) is determined by the sense of helicoidal wire winding.

The helicoidal antennas have the advantage of being very simple to design and  
10 produce and have a considerable band width which ensures high sensitivity; this characteristic of the helicoidal antenna makes the tolerance range wider, making it possible to use inexpensive materials which are easy to obtain on the market. This type of antenna has the added advantage of having a good gain value in an axial direction with an equally good axial ratio that, as the experts in the field know, is the most important reference parameter for  
15 the quality of circular polarization.

The disadvantage of helicoidal antennas is their by no means negligible height which makes them inconvenient for certain applications, such as installation on vehicles or hand-held devices where low profile antennas are required, obviously because they must be streamlined.

20 The low profile is the main characteristic of the second type of antenna mentioned above, known as the patch antenna, where circular polarization is obtained by exciting a resonant current distribution on a planar conducting surface. The direction of circular polarization is determined by a precise calculation of the position of the “point of excitation” of the surface.

This type of antenna, however, requires the use of relatively expensive materials, and, above all great precision during setting up and production due to the small tolerances to respect.

Considering the above state-of-the-art, another type of circular polarization two-way  
5 antenna was designed with the aim of offering all the advantages of both of the above antennas, without the disadvantages or application limitations of either.

### **Summary of the Invention**

An omni-directional antenna which includes a conductive loop element supported  
10 above a conductive ground plane of a wireless communication device by a conductive leg member. The conductive leg member further defines a feedpoint at which the antenna is operatively coupled to the device's signal generating circuitry. A dielectric element may optionally be disposed between the loop and ground plane.

The improved antenna displays gain in both the vertical and horizontal orientations.  
15 The horizontal gain is due to currents in the loop. The vertical gain (perpendicular to the loop and the ground plane) is due to displacement current fields within the conductive leg member disposed between the loop and the ground plane.

Circular polarization is obtained by exciting a wave along a loop wire. The loop defines a closed path, which need not necessarily be a circular path. An antenna including a  
20 rectangularly defined loop is also disclosed herein. Different approaches may be utilized to effect wave polarization (left-hand or right-hand); the first consists in exciting the loop wire at two separate points staggered at an angle of 90 degrees with respect to the center of the loop wire and providing a source in phase quadrature. Alternatively, the loop wire may be excited at only one point by discriminating one of the two polarizations by means of a passive  
25 probe, a directional probe or other suitable means.

The operational frequency band of the antenna is largely determined by the outside circumference dimension of the conductive loop. The outer circumference dimension is substantially equivalent to 1/2 of the wavelength of the frequency of response. Thus the system performs similarly to a 1/2 wave slot antenna. Tuning of the antenna can be  
5 accomplished by adjusting the feed network. Adjusting the width and location of the conductive leg member will transition the frequency and impedance.

Another aspect of the present invention addresses the problem of power loss in the transmission line connecting the antenna to the RF electronics. In embodiments of the present invention, this concern is addressed by providing a low noise amplifier (LNA)  
10 proximate the antenna structure. In one preferred embodiment, the LNA may be disposed within the antenna structure, such as within a cavity defined in a portion of the antenna.

Another aspect of the present invention is the provision of an antenna wherein various components of the transceiver and/or handset, such as a LNA, are placed within or under the antenna, importantly without negatively impacting antenna performance. A LNA with or  
15 without pre/post filter may be disposed within a cavity of a portion of the antenna assembly. In one preferred embodiment, the electronic or other components, may be disposed within a cavity defined within a disk-shaped dielectric element.

Yet another aspect of the present invention is the provision of an antenna structure having a conductive loop resonator element disposed in operative relationship to a conductive  
20 ground plane element. In one embodiment, the conductive ground plane may be the ground plane of a wireless communications device. In another embodiment, the conductive ground plane may be a separate conductive panel or element which is coupled to the ground plane of the wireless device. For example, the antenna may be remotely disposed relative to the wireless device and coupled thereto by a transmission line, such as a coax signal line, etc.

25 Yet another feature of embodiments of the present invention is a notch element in the conductive leg member. Changes in the notch height can be used to adjust the antenna

match. Further tuning can be accomplished by adjusting the width of the ring. As the ring is made wider, the operational frequency range becomes higher.

One advantage of the invention is that the antenna performance is largely independent of the dimensions of the ground plane. Thus the antenna can be readily adapted to different devices having various ground plane dimensions.

The above and other objects and advantageous features of the present invention will be made apparent from the following description with reference to the accompanying drawings, in which like reference characters designate the same or similar parts throughout the drawings.

10

### **DESCRIPTION OF THE DRAWINGS**

Fig. 1 shows a perspective view of a wireless communications device utilizing an antenna according to the present invention;

FIG. 2 is a perspective view of a portion of the wireless communications device of FIG. 1, illustrating the ground plane element and the loop element of the antenna assembly;

FIG. 3 is another perspective view of a portion of the wireless communications device of FIG. 1, illustrating the ground plane element and the loop element of the antenna assembly;

FIG. 4 is a perspective view of the loop element of the antenna assembly of FIG. 3;

FIG. 5 is another perspective view of the loop element of the antenna assembly of FIG. 3;

FIG. 6 is a top plan view of one preferred embodiment of the loop antenna assembly according to the present invention;

FIG. 7 is a side elevational view of the preferred embodiment of FIG. 6;

FIG. 8 is a polar chart of gain characteristics of an antenna assembly of FIG. 6;

FIG. 9 is a VWSR vs. frequency plot of the antenna of FIG. 6;

FIG. 10 is another embodiment of the loop element of the antenna assembly according to the present invention;

FIG. 11 is a top plan view of the antenna assembly of FIG. 10;

FIG. 12 is a side elevational view of the antenna assembly of FIG. 10;

5 FIG. 13 is another embodiment of the loop element of the antenna assembly according to the present invention;

FIG. 14 is a top plan view of the embodiment of FIG. 13;

FIGS. 15-18 are side elevational views of the embodiment of FIG. 13;

FIG. 19 is a perspective view of another embodiment of an antenna assembly  
10 according to the present invention;

FIG. 20 is a perspective view of another embodiment of an antenna assembly according to the present invention;

FIG. 21 is a perspective view of the antenna assembly of FIG. 20;

FIG. 22 is a perspective view of another embodiment of an antenna assembly  
15 according to the present invention illustrating an alternative feed approach; and

FIG. 23 is a perspective view of another embodiment of an antenna assembly according to the present invention illustrating an alternative feed approach.

### **Detailed Description of Preferred Embodiments**

20 FIG. 1 illustrates an antenna assembly 10 disposed within a wireless communications device 12, such as a cellular telephone or PDA device. The antenna assembly 10 includes a circular loop resonator element 14 defining a loop surface 16 disposed away from a ground plane element 20. The ground plane element 20 may be ground plane of a printed wiring board of the device 12 or may be a separate conductive element which is coupled to the  
25 ground plane of the device 12.

In preferred embodiments, the antenna assembly 12 can be implemented to transmit and receive on desired frequencies, including analog or digital U.S. or European cell phone bands, PCS cell phone bands, 2.4 GHz BLUETOOTH® bands, or other frequency bands as would be obvious to one skilled in the art.

5           The antenna assembly 10 is disposed near the upper portion of the device 12 (away from the user's hand during operation), and is received and incorporated within the housing 22 of the device 12. Although the antenna assembly 10 can be installed in locations within or external to the housing 22, it is presently preferred that it be disposed within the housing 22. Wireless communication device 12 contains an electronic device, such as a receiver and/or  
10 transmitter herein referred for convenience together as a transceiver component 24.

Referring now to FIGS. 2-7, the loop surface 16 of the circular loop resonator element 14 is disposed in substantially parallel relationship to the ground plane element 20. Ground plane 20 is illustrated herein as a substantially rectangular form. It should be recognized that ground plane 20 may assume alternative shapes or forms, provided that at least one major  
15 dimension is approximately  $\frac{1}{4}$  wavelength long at the lowest frequency of operation. A conductive leg element 26 is contiguous with and extends from an edge of the loop surface 16 toward the ground plane element and defines a feed tab 28 for the antenna assembly 12. The feed tab 28 is operatively coupled to the transceiver signal input/output component 24, such as via a coax line 25 of FIG. 5. The conductive leg element 26 further defines a ground tab  
20 30 for coupling the leg element 26 to a circuit ground. Loop resonator 14 is thus electrically connected to the ground plane 20 via the ground tab 30. A slot-like removed portion 32 is defined between the feed tab 28 and the ground tab 30 of the conductive leg element 26. In one preferred embodiment, the slot-like removed portion 32 is illustrated as a slot having generally parallel edges. Alternative embodiments of the slot-like removed portion 32 may  
25 be practicable, including but not limited to notch structures, or other removed portions. The dimensions of the loop resonator element 14 may be varied to conform to a portion of the

housing 22. Those skilled in the arts will appreciate that the design and selection of the loop resonator element 14 with reference to a particular wireless communication device may result in such complex shapes.

In the embodiment of FIGS. 2-7, a disk-shaped dielectric element 40 is disposed  
5 between the conductive loop resonator element 14 and the ground plane 20. The dielectric element 40 may include a glass filled polymer such as ULTEM 1000 (available from Boedeker Plastics, Inc. of Shiner, TX) for the dielectric disk. This material is a glass filled polymer which has a dielectric constant of approximately 3.15. This dielectric material is suitable for the antenna 10 to be surface mounted through a thermal reflow solder process.  
10 Other dielectric materials can be used as well. Those skilled in the relevant art will appreciate that selection of a dielectric material having a higher dielectric constant can result in a smaller, more compact, antenna 10. Dielectric constant values are preferably in the range from 1 to 35. The selection of dielectric materials should include considerations including high temperature resistance, and low loss factor for antenna performance. Other dielectric  
15 materials which may be suitable include ceramic materials, and aerogels. Ceramic filled plastics can also be used, such as TMM material manufactured by Rogers Corporation, of Chandler, Arizona, which is available in dielectric constant values from 3 to 10, and which is resistant to solder reflow temperatures. TMM material consists of a hydrocarbon thermoset plastic (ceramic-filled) that provides a tight control of dielectric constant, low loss, and  
20 excellent temperature stability. The dielectric element 40 may include a cavity into which one or more components of the WCD 12 may be disposed. FIGS. 20 – 21 illustrate such an embodiment as further described herein.

The conductive loop resonator element 14 and leg element 26 can be integrally manufactured from a single conductive metal or other suitable conductive material. In one  
25 embodiment, as illustrated in FIGS. 6 and 7, the conductive metal would be 0.25 mm thick brass for operation about the 2.4-2.5 GHz frequency range. The conductive members 14, 26

can be shaped by stamping, milling, plating or other suitable method as would be obvious to one skilled in the relevant arts. The conductive members 14, 26 may also be overmolded with a polymeric dielectric 40, or mechanically secured onto the dielectric member 40. In another embodiment (not shown), the conductive members 14, 26 may be selectively plated  
5 onto the dielectric member 40 using electrolytic or electroless or other suitable methods. One particular method would employ the MID technology of two shot molding followed by electroless plating. In another embodiment the manufacturing method may employ insert molding over the existing conductive portion.

The loop resonator element 14 can be soldered onto the wiring board of the  
10 communication device 12 for electrical and mechanical coupling of the feed tab 28 to the signal transceiver component 24, and the ground tab 30 to the ground portion of the transceiver component 24. Alternatively, a microstrip feedline (not shown) from the communication device 12 to the antenna 10 can also be employed.

A primary advantage of this invention is that multiple polarizations can be obtained  
15 from a very compact design. As illustrated in FIG. 8, the unit produces right hand and left hand circular polarizations as well as vertical and horizontal responses. With reference to FIG. 3, the right hand side of the antenna 10 transmits and receives right hand circular polarized radiation, while the left side of the antenna 10 transmits and receives left hand circular polarized radiation. The antenna 10 also transmits and receives vertical polarization  
20 in the azimuthal direction which is nearly perfectly omni-directional, and horizontal polarization at zenith.

As a result, the antenna 10 is particularly well suited for GPS usage at 1.575 GHz due to the right hand circular polarization response. The antenna 10 can also be built scaled in size to perform in the BLUETOOTH® frequency band, at 2.4 GHz. This antenna 10 is also  
25 well suited for BLUETOOTH® and ISM applications since the multiple dimensions of polarization performance allow the unit to be oriented in many angles of configuration and

still have good response. Thus the antenna 10 can be used in a handheld device 12 which can be carried in any orientation and still provide acceptable signal transmission and reception quality.

Referring again to FIG. 8, it has been determined that the antenna has both a right hand and left hand CP component at  $\Theta=90^\circ$  and  $-90^\circ$  respectively. The antenna 10 can be considered as a 1/2 wave loop antenna with an electrical distance around the ring of 1/2 wavelength at 2.45 GHz. Describing the antenna 10 in this manner leads to the definition of points about the ring corresponding to distances along the wavelength. In Figure 3 the 0, 1/4 and 1/2 wavepoints are indicated by A, B and C respectively.

At resonance, a current standing wave (CSW) is set up around the ring 16. In addition, a voltage standing wave (VSW), phase shifted  $90^\circ$ , is established between the ring 16 and the groundplane 20. The conduction current of the CSW produces a horizontally polarized E-field and the displacement current from the VSW produces a vertically polarized E-field. Circular polarization requires a  $90^\circ$  phase shift between polarizations, which is inherent in this design. As a second requirement for circular polarization, the E-fields from the two polarizations must be equal in magnitude. This second requirement does not occur at any of the locations on the ring having either a current or a voltage null (0, 1/4 and 1/2 wave points). However, between these locations, including possibly the 1/8 or 3/8 wave points, it may occur that the magnitude of the E-field components are approximately equal. In addition, the antenna assembly 10 may display right- and left-hand circular polarization responses at  $\Theta=90^\circ$  and  $-90^\circ$  respectively, near the 1/8 and 3/8 wavelength points. FIG. 9 illustrates the voltage standing wave ratio (VWSR) vs. frequency plot for the antenna of FIGS. 6-7. The radiation pattern of this particular antenna is nearly omnidirectional for vertical polarization, in the plane which is parallel to the ground plane. In comparison, this radiation pattern is substantially different from a typical PIFA antenna pattern.

Minor tuning adjustments may be necessary upon integration of the antenna assembly 19 into the wireless device 12. Two dimensions on the antenna 10 can be adjusted to tune the antenna 10 into the desired operational band. To tune the antenna 10 to a lower frequency, material can be removed from the left side of the conductive leg element 26 and ground tab 30 as shown in FIG. 4 as phantom lines 60. Changes should be of the order of 0.25 mm to change the resonance frequency by 25 MHz. These numbers are not exact but do give an order of magnitude. This removal of the material makes the slot longer and thereby lowers the frequency. To adjust the match to a higher impedance the slot between the leg element 26 and ground tab 30 and the feed tab 26 should be lengthened (as indicated by phantom line 70 in FIG. 4). Relatively minor changes of the order of 0.25 mm should be necessary.

FIGS. 10-12 illustrate another embodiment of an antenna assembly 10 for a wireless communications device 10. In this embodiment, a conductive leg member 50 includes a feed point 52 defined a distance away from both the ground plane 20 of the device 12 and the ground tab 54 of the conductive leg member 50. Coupling to the device transceiver component 24 may be via a coax or other signal line.

FIGS. 13-18 illustrate yet another embodiment of an antenna assembly 10 for a wireless communications device 10. The loop resonator 14 and dielectric substrate element 40 of this embodiment are preferably rectangular in form, and yet more preferably substantially square in shape. FIGS. 14 – 18 are additional views of the antenna of FIG. 13. The antenna of FIGS. 13-18 include a plurality of side conductor panels 70, 72, 74 electrically coupled to the loop resonator element 14 proximate its perimeter. In this embodiment, a conductive leg member 60 includes a feed point 62 defined a distance away from both the ground plane 20 of the device 12 and the ground tab 64 of the conductive leg member 60. As a result, a 50 ohm unbalanced electrical feed point is provided between feed point 62 and ground tab 64. Coupling to the device transceiver component 24 may be via a coax or other signal line.

Referring now to FIG. 19, another embodiment of an antenna assembly 10 according to the present invention is illustrated. In this embodiment, the antenna 10 may be disposed away from the associated wireless communications device 12. The loop surface 16 of the circular loop resonator element 14 is disposed in substantially parallel relationship to the ground plane element 20 which may be a conductive element separate from the ground plane of the wireless device 12. It should be recognized that ground plane 20 may assume alternative shapes or forms, provided that at least one major dimension is approximately  $\frac{1}{4}$  wavelength long at the lowest frequency of operation. A conductive leg element 26 is contiguous with and extends from an edge of the loop surface 16 toward the ground plane element and defines a feed tab 28 for the antenna assembly 12. The feed tab 28 is operatively coupled via a conductor 78 to the output 80 of a low noise amplifier 82 which is coupled to a transmission line, such as coax line 25. The shield conductor 84 of the coax line 25 is coupled to the ground plane 20 of the antenna assembly. In this embodiment of the present invention, a component, such as a low noise amplifier 82, is disposed between in a region 81 between the conductive loop resonator element 14 and the ground plane 20. One or more components, such as circuits or other electronic devices or systems, may be disposed in such relationship, i.e., between the conductive loop resonator element 14 and the ground plane 20. It has been determined that for preferred operability of the antenna assembly 10 the height of the component(s) or circuit(s) disposed between the loop resonator element 14 and the ground plane 20 should be less than approximately 50% of the distance between the loop resonator 14 and the ground plane 20.

Similar to the embodiment of FIGS. 3-7, the conductive leg element 26 further defines a ground tab 30 for coupling the leg element 26 to the ground plane 20. Loop resonator 14 is thus electrically connected to the ground plane 20 via the ground tab 30. A slot 32 is defined between the feed tab 28 and the ground tab 30 of the conductive leg element 26. The dimensions of the loop resonator element 14 may be varied to conform to a

portion of the housing 22. Those skilled in the arts will appreciate that the design and selection of the loop resonator element 14 with reference to a particular wireless communication device 12 may result in such complex shapes.

In the embodiment of FIGS. 20 and 21, a disk-shaped dielectric element 40 is  
5 disposed in the region 81 between the conductive loop resonator element 14 and the ground plane 20. The dielectric element 40 may include a glass filled polymer such as ULTEM 1000 (available from Boedeker Plastics, Inc. of Shiner, TX) for the dielectric disk. This material is a glass filled polymer which has a dielectric constant of approximately 3.15. This dielectric material is suitable for the antenna 10 to be surface mounted through a thermal reflow solder  
10 process. Other dielectric materials can be used as well. Those skilled in the relevant art will appreciate that selection of a dielectric material having a higher dielectric constant can result in a smaller, more compact, antenna 10. Dielectric constant values are preferably in the range from 1 to 35. The selection of dielectric materials should include considerations including high temperature resistance, and low loss factor for antenna performance. Other dielectric  
15 materials which may be suitable include ceramic materials, and aerogels. Ceramic filled plastics can also be used, such as TMM material manufactured by Rogers Corporation, of Chandler, Arizona, which is available in dielectric constant values from 3 to 10, and which is resistant to solder reflow temperatures. TMM material consists of a hydrocarbon thermoset plastic (ceramic-filled) that provides a tight control of dielectric constant, low loss, and  
20 excellent temperature stability. As particularly illustrated in FIG. 21, the dielectric element 40 may include a cavity 86 into which one or more components of the WCD 12, such as the low noise amplifier 82, may be disposed. One or more components of the wireless device 12 may be placed within the cavity or cavities 86 of a dielectric element 40.

Referring now to FIGS. 22 and 23, alternative feed approaches are illustrated for use  
25 with a loop resonator element 14. The feed structure 90 of FIG. 22 includes a pair of conductive wires 92, 94 coupled to the center conductor 83 and shield conductor 84 of coax

line 25, respectively. Shield conductor 84 and conductive wire 94 are connected to the ground plane 20. The conductive wires 92, 94 may have circular cross sections with a diameter,  $D_2$ . The conductive wires 92, 94 are disposed away from each other a distance,  $D_1$ . Tuning of the feed structure 90 may be accomplished by varying the distances  $D_1$  and  $D_2$ .

5           The feed structure 98 of FIG. 23 is a high impedance (voltage feed) structure which includes an inductor 100 and capacitor 102 coupled in parallel. The inductor 100 and capacitor 102 may be separate, discrete components, or may be incorporated within a LC tuning network. The center conductor 83 of a coax feed line 25 is coupled proximate to the inductor 100, and the shield conductor 84 is coupled to the ground plane 20. The feed  
10 structures 90, 98 of FIGS. 22 and 23 are illustrated to include a coax signal line 25. Alternative signal lines may also be practicable in alternative embodiments of the antenna, e.g., a micro-strip transmission line.

          Although the invention has been described in connection with particular embodiments thereof other embodiments, applications, and modifications thereof which will be obvious to  
15 those skilled in the relevant arts are included within the spirit and scope of the invention.

1. An antenna assembly for a wireless communications device operating at a predetermined operational wavelength and having a transceiver circuit including a signal port and a ground plane, said antenna assembly comprising:

a generally planar conductive loop element having an electrical length of approximately one half of the predetermined wavelength, said conductive loop element being disposed a predetermined distance away from the ground plane and in general parallel alignment with the ground plane to define a region between the loop element and the ground plane, said region sized to receive a component associated with the wireless communications device; and

a conductive feed structure coupled to the conductive loop element and extending toward the ground plane, said conductive feed structure having a feed point connection and a ground connection.

2. An antenna assembly according to claim 1, wherein the feed structure includes a leg member having an upper end and a lower end, said upper end being coupled to the loop element, said lower end being coupled to the ground plane at a ground connection location and the signal output at a feed point location, said leg member having a slot-like removed portion defined between the feed point location and the ground connection location.

3. An antenna assembly according to claim 1, wherein the feed structure includes a pair of conductive wires, a first wire defining the feed point connection and the other wire defining the ground connection.

4. An antenna assembly according to claim 1, wherein the feed structure includes an inductor and a capacitor coupled in parallel.

5. An antenna assembly according to claim 1, wherein the predetermined distance between the conductive loop element and the ground plane is between approximately 0.02 to 0.06 of the operational wavelength.

6. An antenna assembly according to claim 1, wherein the loop element has a generally rectangular cross section.

7. An antenna assembly according to claim 2, wherein the conductive leg member is generally planar and includes a feed tab at the feed point location and a grounding tab at the ground connection location.

8. An antenna assembly according to claim 2, wherein the conductive loop element and the conductive leg member are integrally formed from a single metal part.

9. An antenna assembly according to claim 1, further comprising:  
a dielectric element disposed in the region between the loop element and the ground plane.

10. An antenna assembly according to claim 9, wherein the dielectric element is in contact with the loop element.

11. An antenna assembly according to claim 10, wherein the dielectric element includes an interior cavity capable of receiving the component associated with the wireless communications device.

12. An antenna assembly of claim 11, wherein the electronic component has a height dimension of approximately 50% of an interior cavity height dimension.

13. An antenna assembly of claim 12, wherein the electronic component includes a low noise amplifier having an output which is coupled to loop element proximate the feed point location.

14. An antenna assembly for a wireless communications device including a printed wiring board having a signal output connection and a ground plane, said antenna assembly comprising:

a conductive loop element having an electrical length of approximately one half of a predetermined operational wavelength, said loop element being disposed in general parallel alignment with the ground plane, wherein a region is defined between the loop element and the ground plane, said region sized to receive a component associated with the wireless communications device; and

a conductive feed structure coupled to the conductive loop element and extending toward the ground plane, said conductive feed structure having a feed point connection and a ground connection.

15. An antenna assembly according to claim 14, wherein the feed structure includes a leg member having an upper end and a lower end, said upper end being coupled to the loop element, said lower end being coupled to the ground plane at a ground connection location and the signal output at a feed point location, said leg member having a slot-like removed portion defined between the feed point location and the ground connection location.

16. An antenna assembly according to claim 14, wherein the feed structure includes a pair of conductive wires, a first wire defining the feed point connection and the other wire defining the ground connection.

17. An antenna assembly according to claim 14, wherein the feed structure includes an inductor and a capacitor coupled in parallel.

18. An antenna assembly according to claim 15, wherein the predetermined distance between the loop element and the ground plane is between approximately 0.02 to 0.06 of the operational wavelength.

19. An antenna assembly according to claim 15, wherein the leg member is disposed in substantially perpendicular relationship to the loop element.

20. An antenna assembly according to claim 14, wherein the loop element has a generally rectangular cross section.

21. An antenna assembly of claim 14, wherein the loop element is generally circular.

22. An antenna assembly according to claim 15, wherein the conductive leg member is generally planar and includes a feed tab at the feed point location and a grounding tab at the ground connection location.

23. An antenna assembly according to claim 15, wherein the conductive loop element and the conductive leg member are integrally formed from a single metal part.

24. An antenna assembly according to claim 14, further comprising:  
a dielectric element disposed in the region between the loop element and the ground plane.

25. An antenna assembly according to claim 24, wherein the dielectric element is in contact with the loop element.

26. An antenna assembly according to claim 24, wherein the dielectric element includes an interior cavity capable of receiving the component associated with the wireless communications device.

27. An antenna assembly of claim 26, wherein the component has a height dimension of approximately 50% of an interior cavity height dimension.

28. An antenna assembly of claim 27, wherein the electronic component includes a low noise amplifier having an output which is coupled to loop element proximate the feed point location.

29. An antenna assembly of claim 14, wherein the loop element is disposed on a side of the printed wiring board which faces away from a user during intended operation of the wireless communications device.

30. An antenna assembly for a wireless communications device including a printed wiring board having a signal output connection and a ground plane, said antenna assembly comprising:

a substantially planar conductive element having an electrical length of approximately one half of a predetermined operational wavelength and being operatively coupled to the signal output connection, said element being disposed in general parallel alignment with the ground plane, wherein a region is defined between the conductive element and the ground plane, said region sized to receive a component associated with the wireless communications device; and

a conductive leg member having an upper end and a lower end, said upper end being coupled to the conductive element, said lower end being coupled to the ground plane at a ground connection location.

31. An antenna assembly according to claim 30, wherein the conductive leg member is coupled to the signal output connection at a feed point location, said leg member having a slot-like removed portion defined between the feed point location and the ground connection location.

32. An antenna assembly according to claim 30, wherein the predetermined distance between the conductive element and the ground plane is between approximately 0.02 to 0.06 of the operational wavelength.

33. An antenna assembly according to claim 30, wherein the leg member is disposed in substantially perpendicular relationship to the conductive element.

34. An antenna assembly according to claim 30, wherein the conductive element is a generally circular loop.

35. An antenna assembly according to claim 30, wherein the conductive leg member is generally planar and includes a feed tab at the feed point location and a grounding tab at the ground connection location.

36. An antenna assembly according to claim 30, further comprising:  
a dielectric element disposed in the region between the conductive element and the ground plane.

37. An antenna assembly according to claim 36, wherein the dielectric element is in contact with the conductive element.

38. An antenna assembly according to claim 36, wherein the dielectric element includes an interior cavity capable of receiving the component associated with the wireless communications device.

39. An antenna assembly according to claim 38, wherein the component has a height dimension of approximately 50% of an interior cavity height dimension.

40. An antenna assembly according to claim 39, wherein the electronic component includes a low noise amplifier having an output which is coupled to conductive element proximate a feed point location.

41. An antenna assembly according to claim 30, wherein the conductive element is disposed on a side of the printed wiring board which faces away from a user during intended operation of the wireless communications device.

FIG. 1

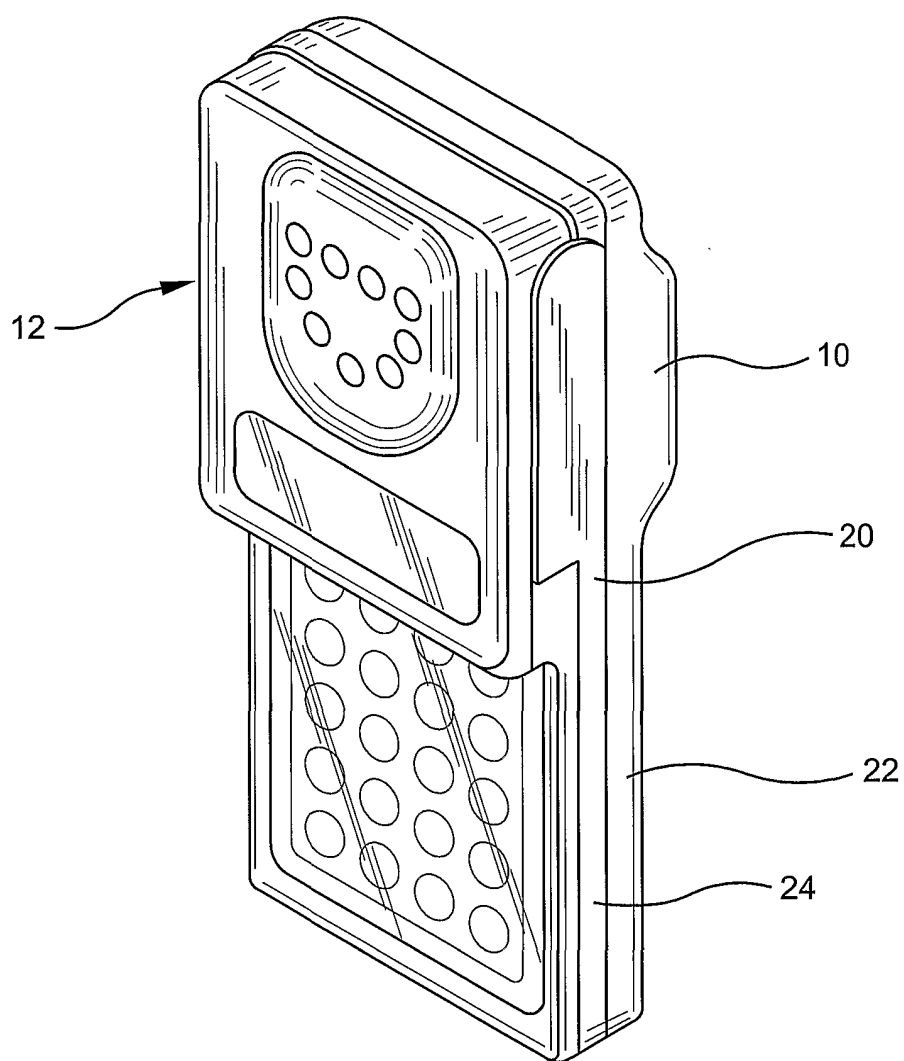

FIG. 2

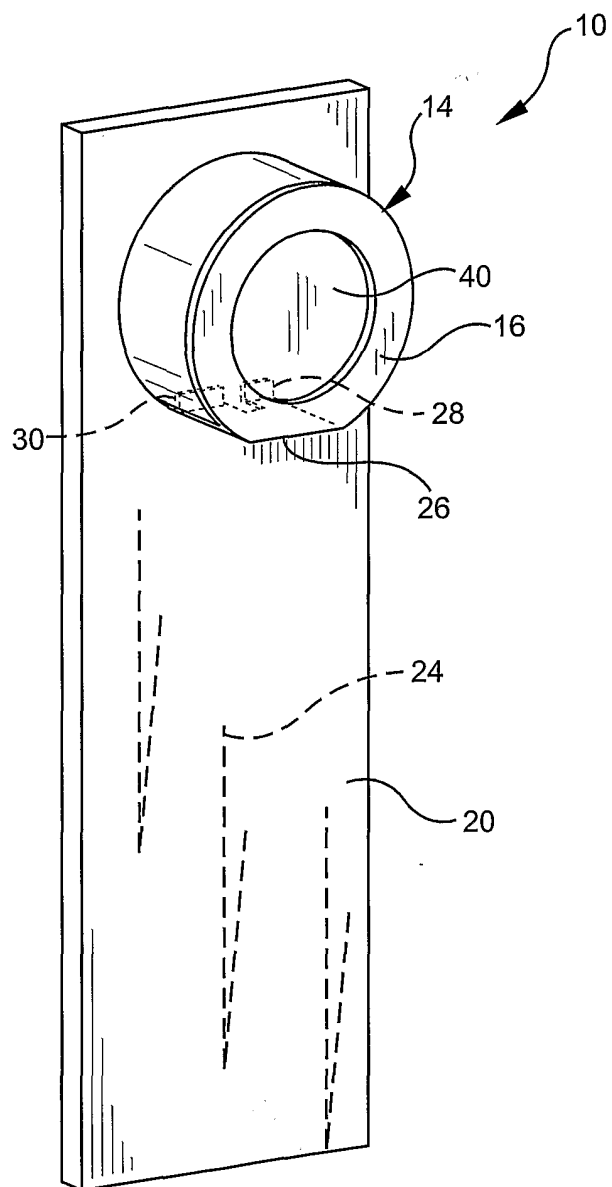

FIG. 3

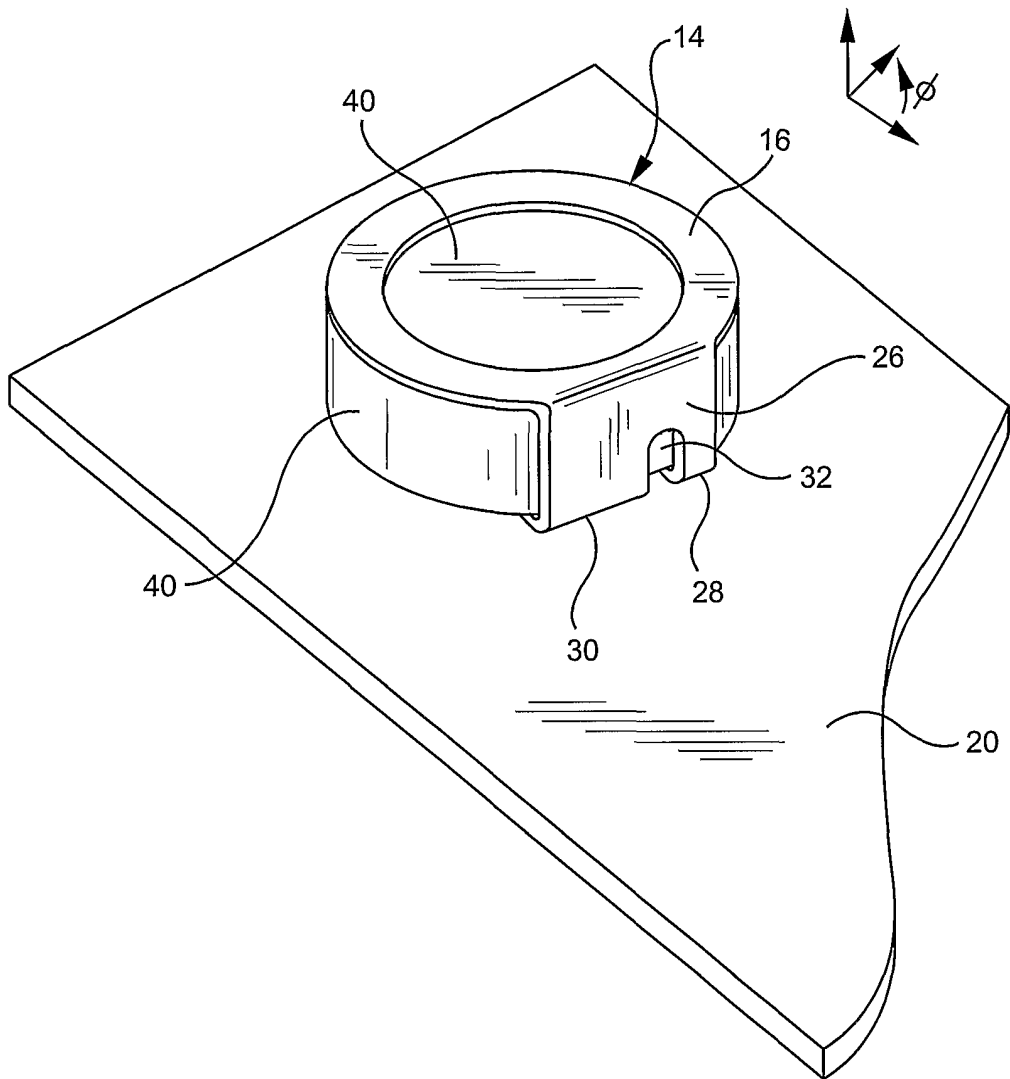

FIG. 4

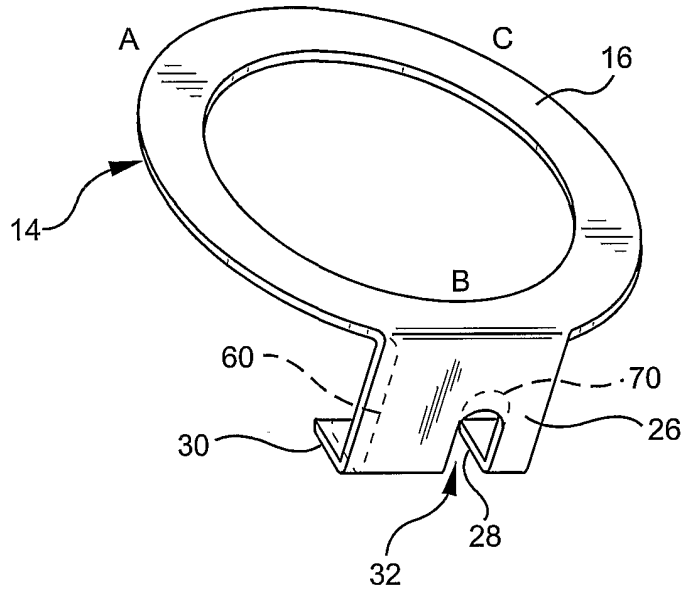

FIG. 5

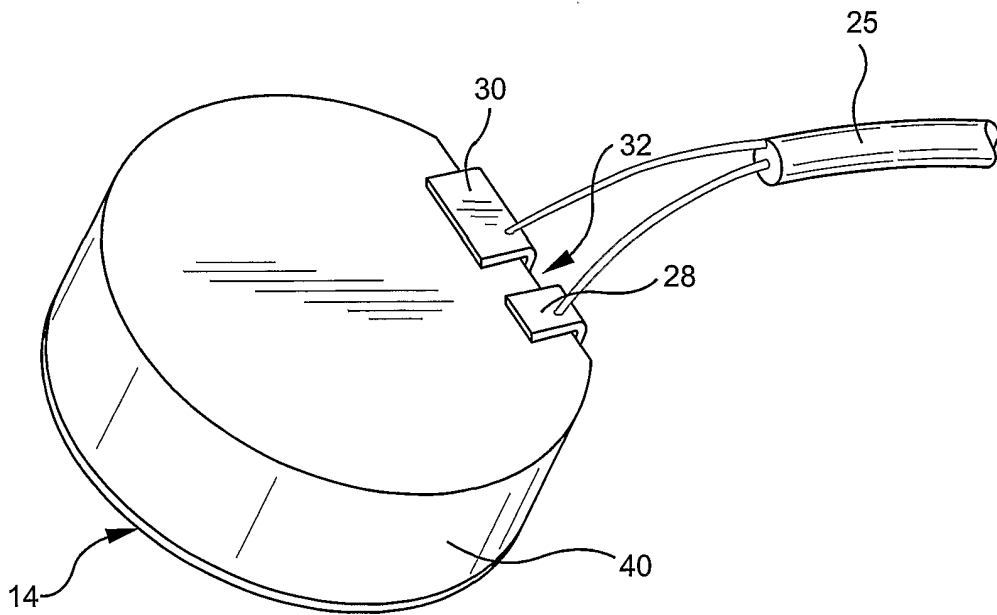
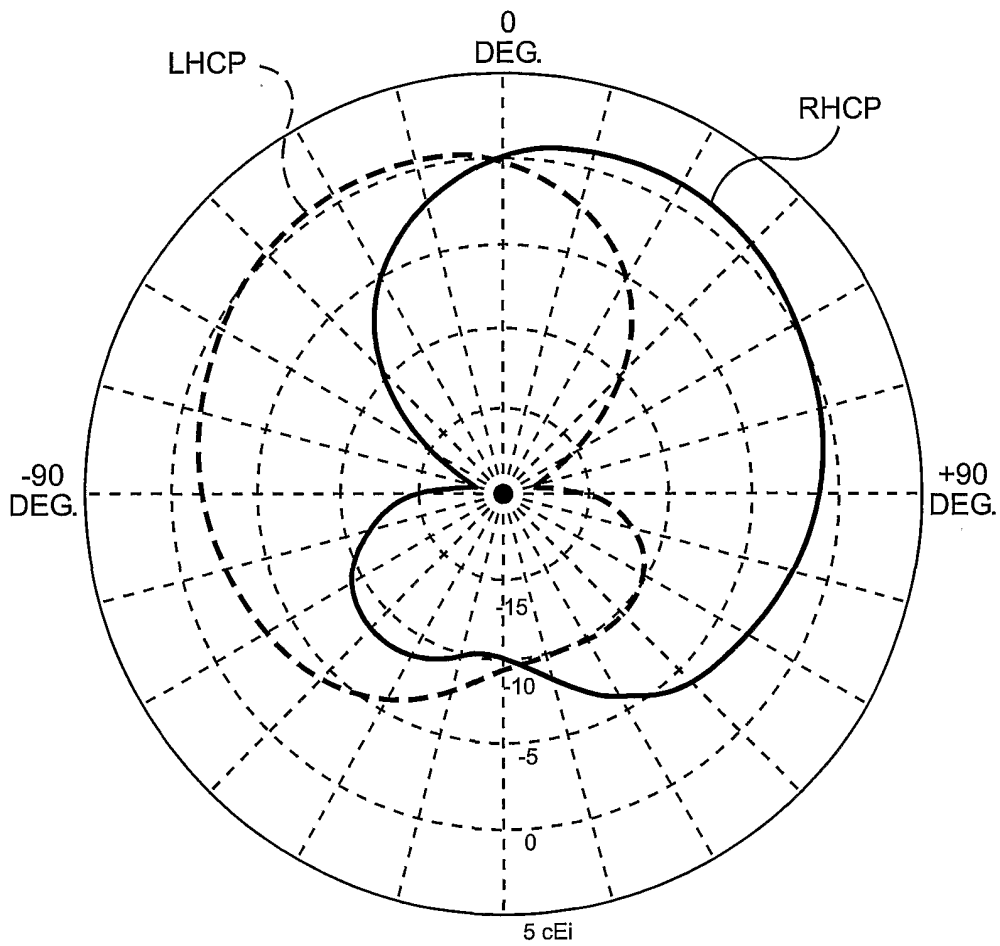



FIG. 8



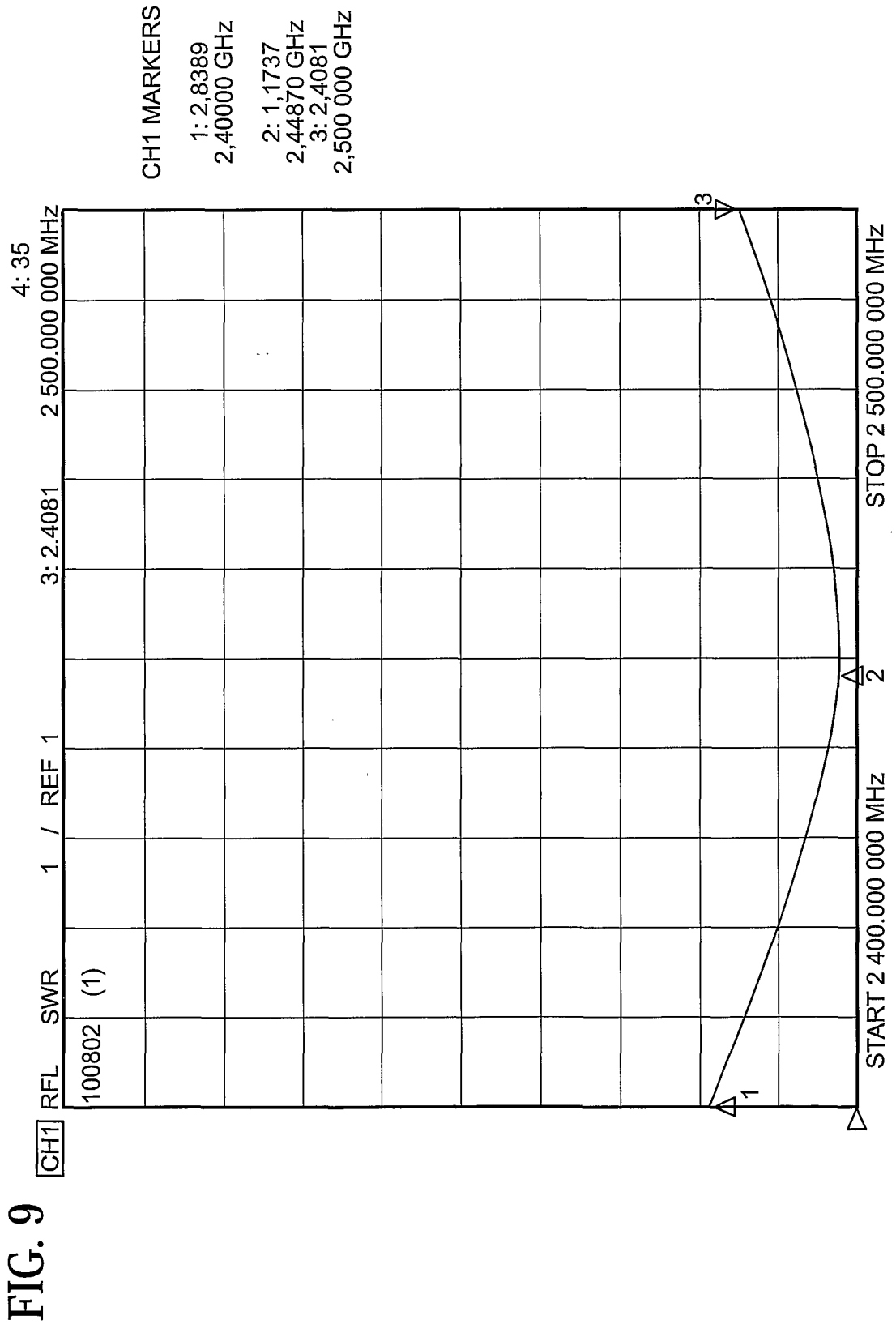
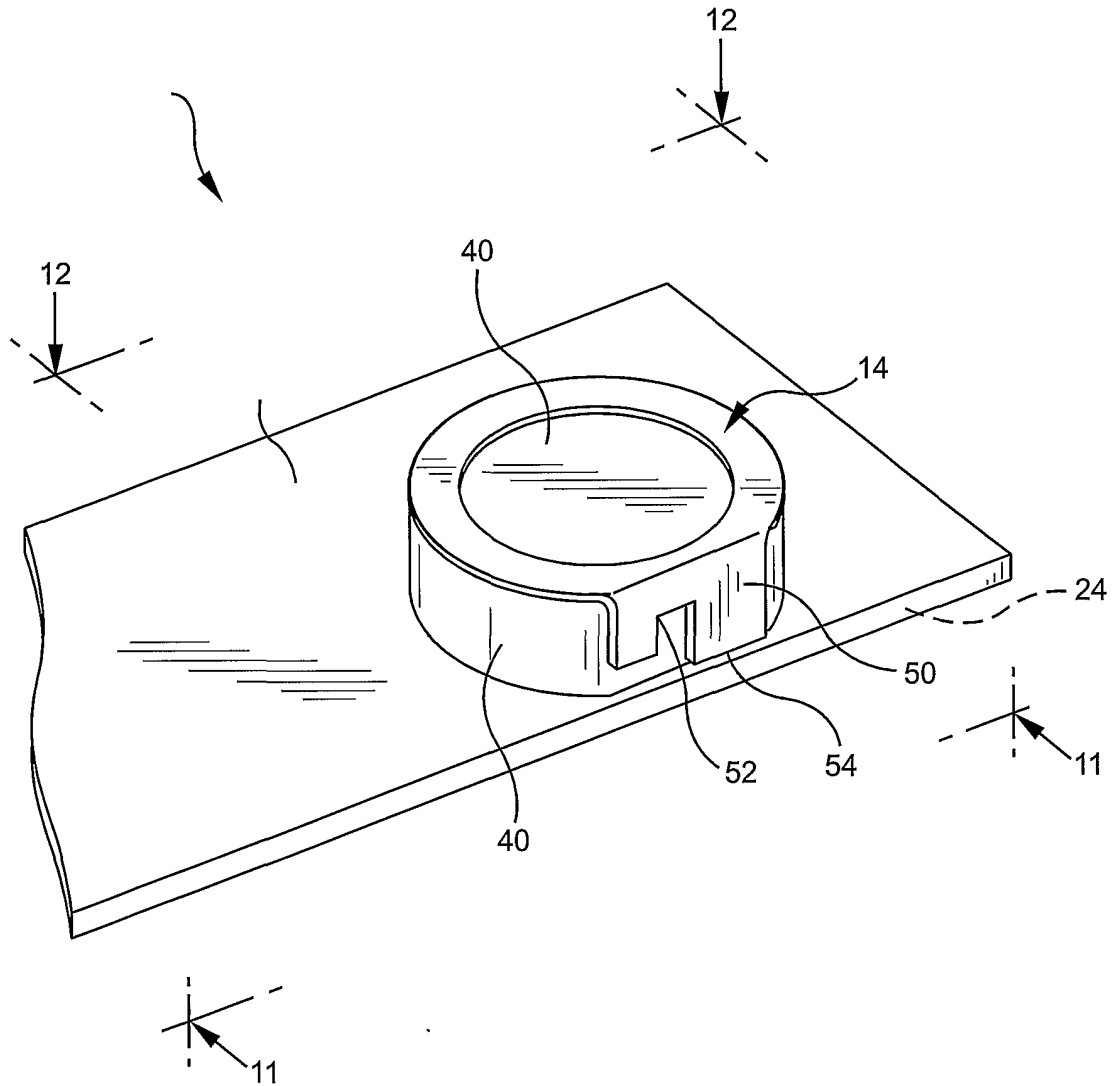

FIG. 10



9/17

FIG. 11

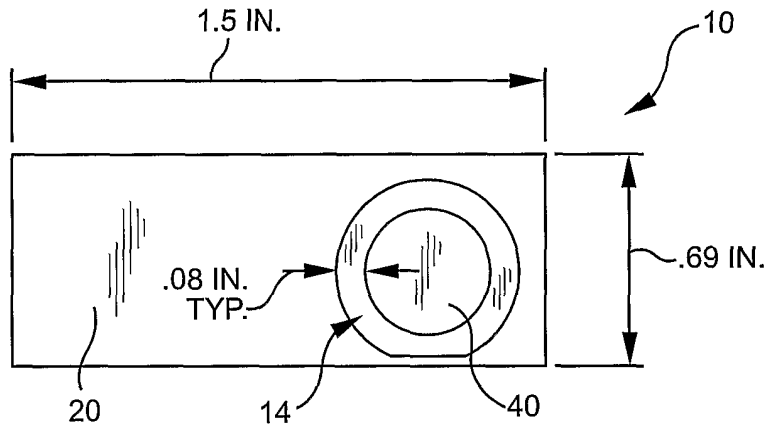

FIG. 12

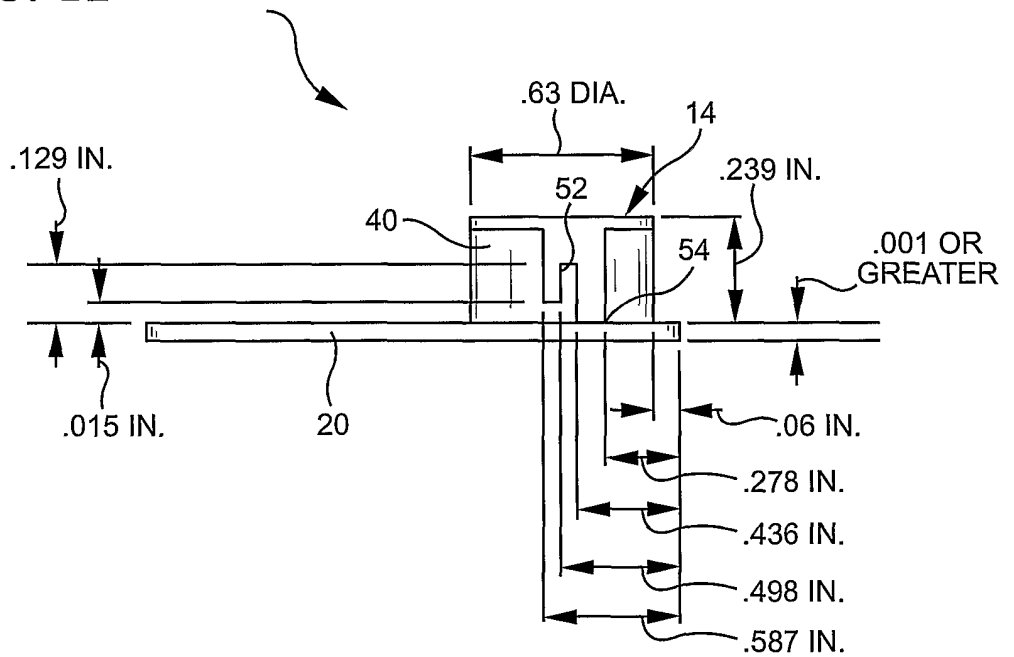

FIG. 13

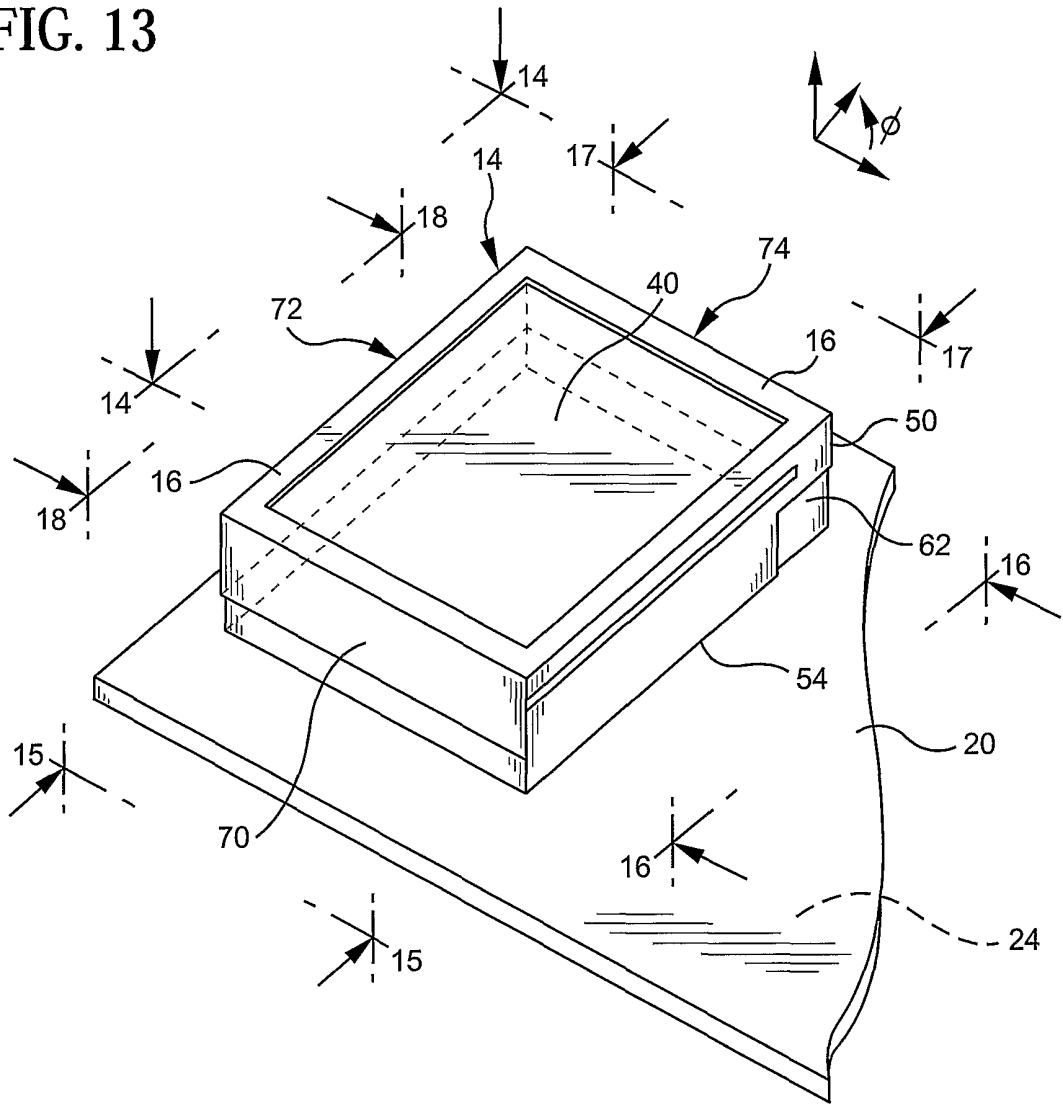

FIG. 14

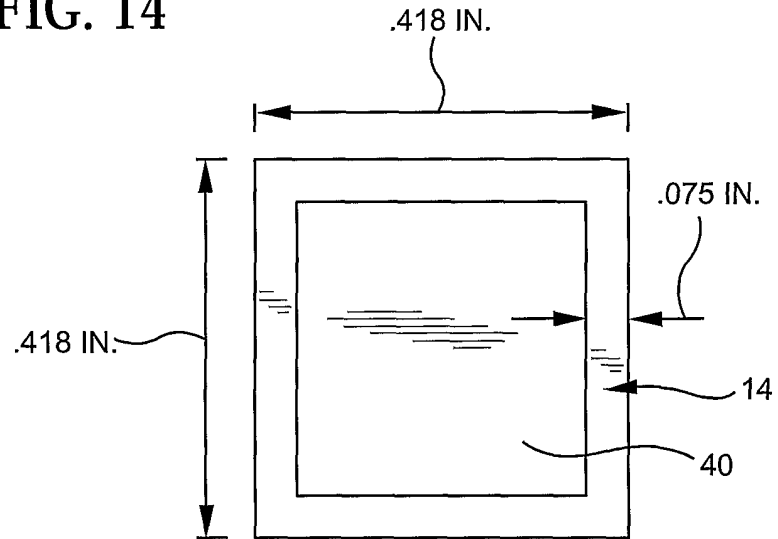
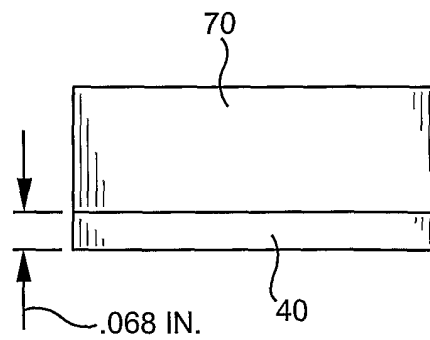

FIG. 15



12/17

FIG. 16

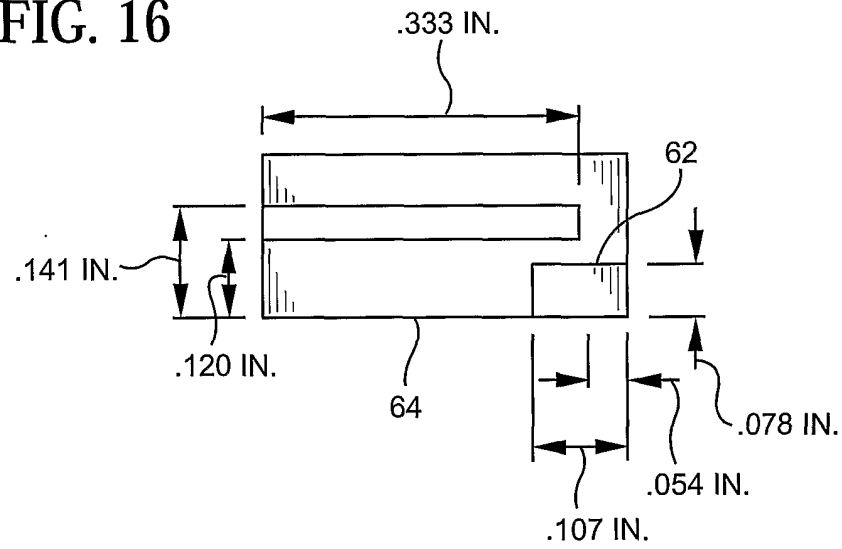

FIG. 17

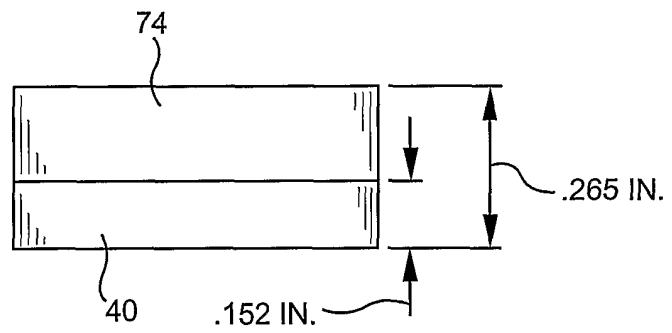

FIG. 18

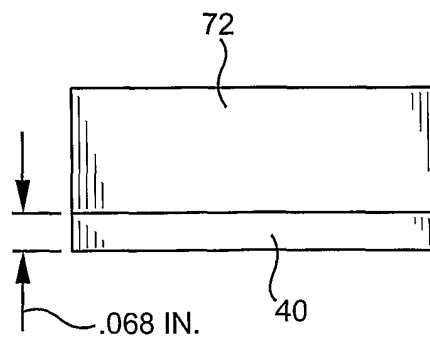

FIG. 19

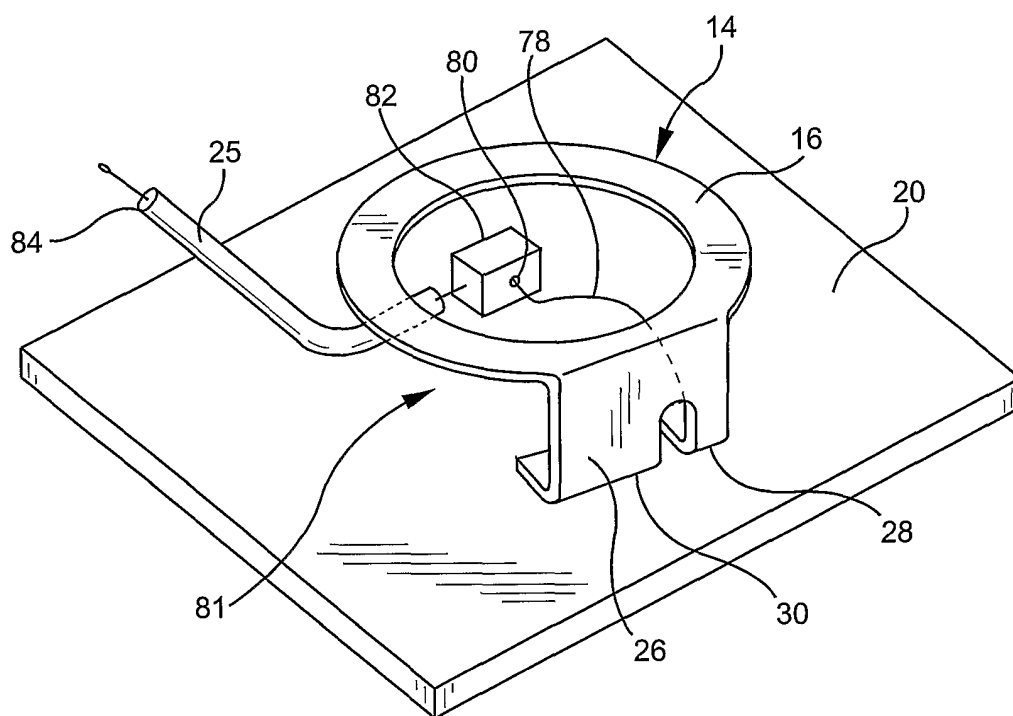



FIG. 21

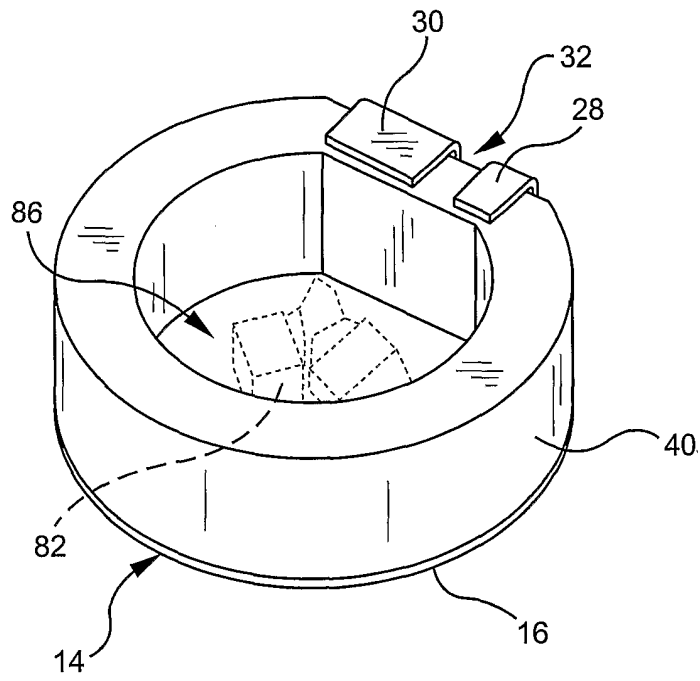

FIG. 22

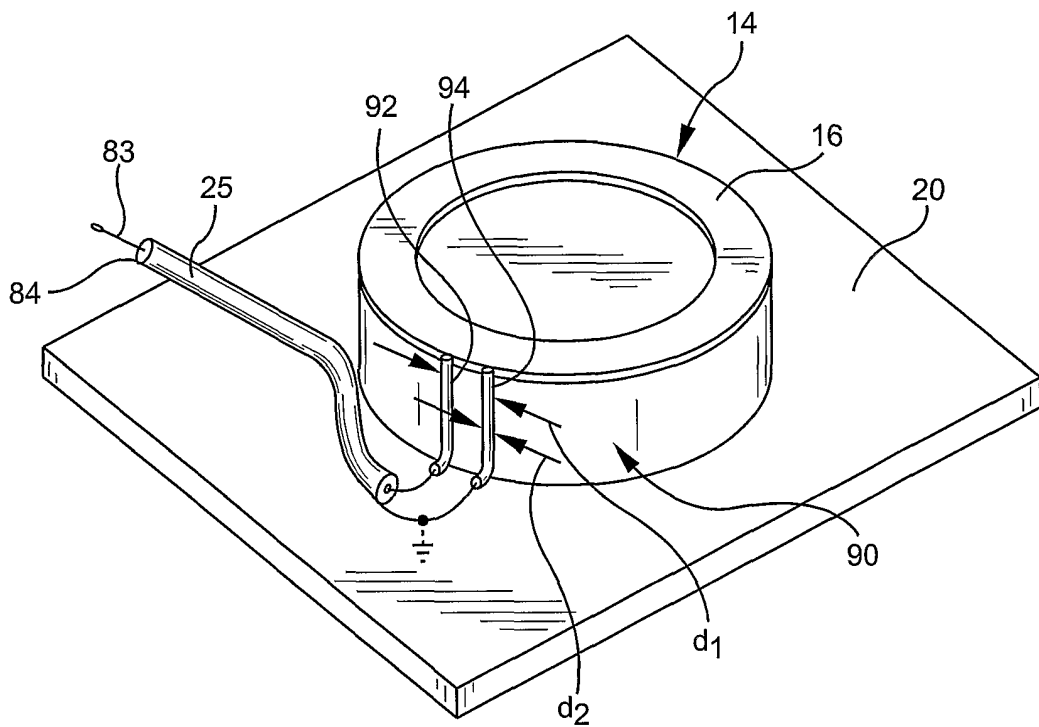
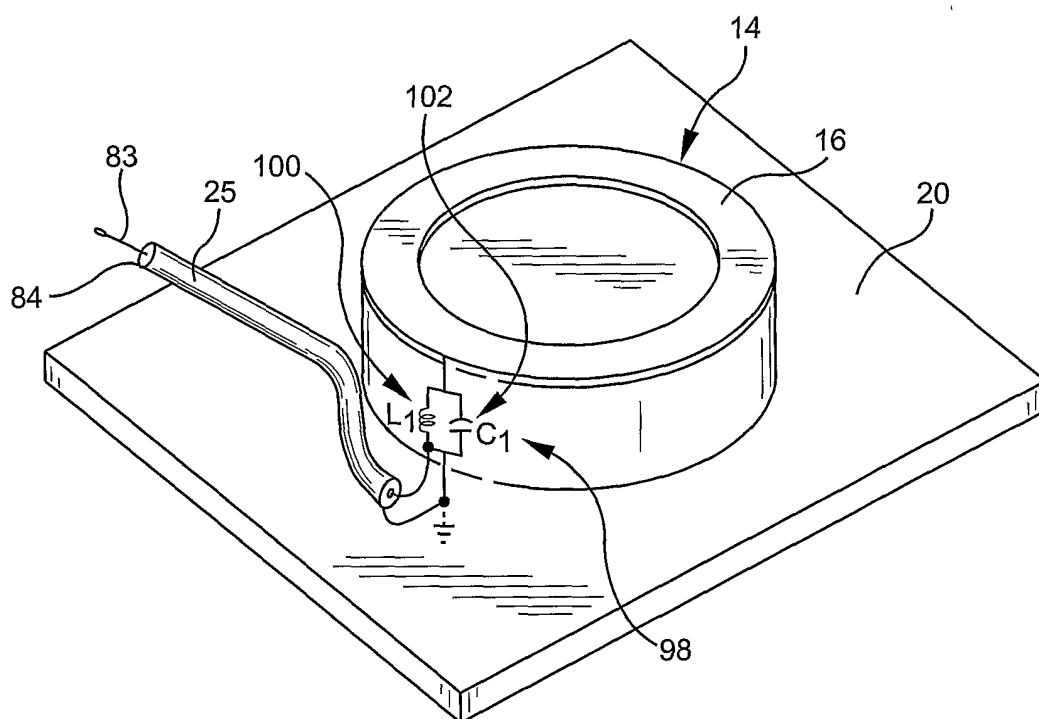

FIG. 23



INTERNATIONAL SEARCH REPORT

International application No.  
PCT/US01/30234

**A. CLASSIFICATION OF SUBJECT MATTER**

IPC(7) :H01Q 1/24; 7/00  
US CL :343/702, 726, 728, 732, 741, 742, 748, 764, 866.

According to International Patent Classification (IPC) or to both national classification and IPC

**B. FIELDS SEARCHED**

Minimum documentation searched (classification system followed by classification symbols)

U.S. : 343/702, 726, 728, 732, 741, 742, 748, 764, 866.

Documentation searched other than minimum documentation to the extent that such documents are included in the fields searched

Electronic data base consulted during the international search (name of data base and, where practicable, search terms used)

**C. DOCUMENTS CONSIDERED TO BE RELEVANT**

Category*	Citation of document, with indication, where appropriate, of the relevant passages	Relevant to claim No.
X	US 5,943,020 A (Liebendoerfer et al) 24 August 1999 (24/08/1999), Fig. 1, col. 3, line 43+, col. 4.	1-2,6-8,14-15,19-20,22-23, 29-31,33,35, 41
A		----- 3-5,9-13, 16-18,21, 24-28,32,34, 36-40

Further documents are listed in the continuation of Box C.  See patent family annex.

* Special categories of cited documents:	"T" later document published after the international filing date or priority date and not in conflict with the application but cited to understand the principle or theory underlying the invention
"A" document defining the general state of the art which is not considered to be of particular relevance	"X" document of particular relevance; the claimed invention cannot be considered novel or cannot be considered to involve an inventive step when the document is taken alone
"E" earlier document published on or after the international filing date	"Y" document of particular relevance; the claimed invention cannot be considered to involve an inventive step when the document is combined with one or more other such documents, such combination being obvious to a person skilled in the art
"L" document which may throw doubts on priority claim(s) or which is cited to establish the publication date of another citation or other special reason (as specified)	"&" document member of the same patent family
"O" document referring to an oral disclosure, use, exhibition or other means	
"P" document published prior to the international filing date but later than the priority date claimed	

Date of the actual completion of the international search 08 NOVEMBER 2001	Date of mailing of the international search report 28 DEC 2001
---	---

Name and mailing address of the ISA/US  
Commissioner of Patents and Trademarks  
Box PCT  
Washington, D.C. 20231

Facsimile No. (703) 305-3230

Authorized officer

TRINH VO DINH

Telephone No. (703) 305-4575

Deborah Perry-Leeper  
Paralegal Specialist

Technology Center 2800

## INTERNATIONAL SEARCH REPORT

International application No.  
PCT/US01/30234

## C (Continuation). DOCUMENTS CONSIDERED TO BE RELEVANT

Category*	Citation of document, with indication, where appropriate, of the relevant passages	Relevant to claim No.
X,P	US 6,236,368 B1 (Johson) 22 May 2001 (22/05/2001), Figs. 1, 4; cols. 2, lines 39-67, col. 4.	1,3,9-10,14, 16,24-25,30- 32,36-37,41
-----		-----
A,P		2,4-8,11-13, 15,26-28,31, 33-35,38-40
Y	US 6,034,636 A (Saitoh) 07 March 2000 (07/03/2000), Figs.1A, 3, cols. 2, 4.	1-2,7-10, 14-15,19, 22-25,29-31, 33,35-37,41
-----		-----
A		3-6,11-13,16- 18,20-21,26-2 8,32,34,38-40
Y,P	US 6,255,994 B1 (Saito) 03 July 2001 (03/07/2001), Figs. 4, 12, 17-18, col.s 6-7.	1-2,7-10, 14-15,19, 22-25,29-31, 33,35-37,41.
-----		-----
A		3-6,11-13,16- 18,20-21,26- 28,32,34,38-40
X,P	US 6,188,371 B1 (Li et al) 13 February 2001 (013/02/2001), Figs 1-3, cols. 2-3.	1-2,7-8,14-15 19,22-23, 29-31,33,35, 41.
-----		-----
A		3-6,9-13,16-1 8,20-21,24- 28,32,34,36-40
A,P	US 6,239,753 B1 (Kado et al) 29 May 2001 (29/05/2001), Figs 1,4,8, cols. 6-7.	1-41
A	US 5,847,683 A (Wolfe et al) 08 December 1998 (08/12/1998), Figs. 1-2, cols. 1-3.	1-41
A,P	US 6,243,045 B1(Ishibashi) 05 June 2001 (05/06/2001), Fig. 9.	1-41

## INTERNATIONAL SEARCH REPORT

International application No.  
PCT/US01/30234

C (Continuation). DOCUMENTS CONSIDERED TO BE RELEVANT		
Category*	Citation of document, with indication, where appropriate, of the relevant passages	Relevant to claim No.
A,P	US 6,292,152 B1 (Cosenza et al) 18 September 2001 (18/09/2001), Figs. 1,10-11, col. 4.	1-41
A	US 5,969,681 A (O'Neill, Jr.) 19 October 1999 (19/10/1999), Fig. 4.	1-41