

July 11, 1961

T. E. ARMSTRONG

2,991,826

GYPSUM WALLBOARD

Filed Sept. 11, 1957

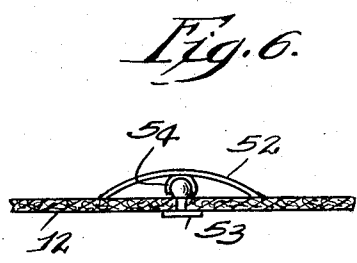
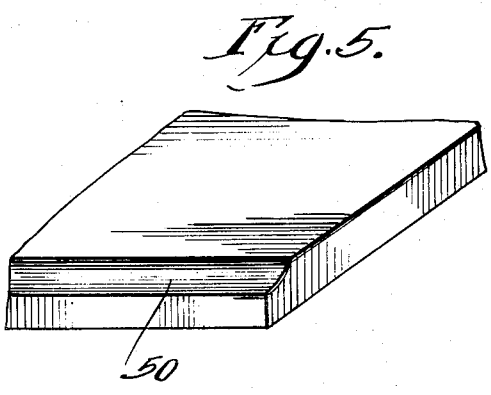
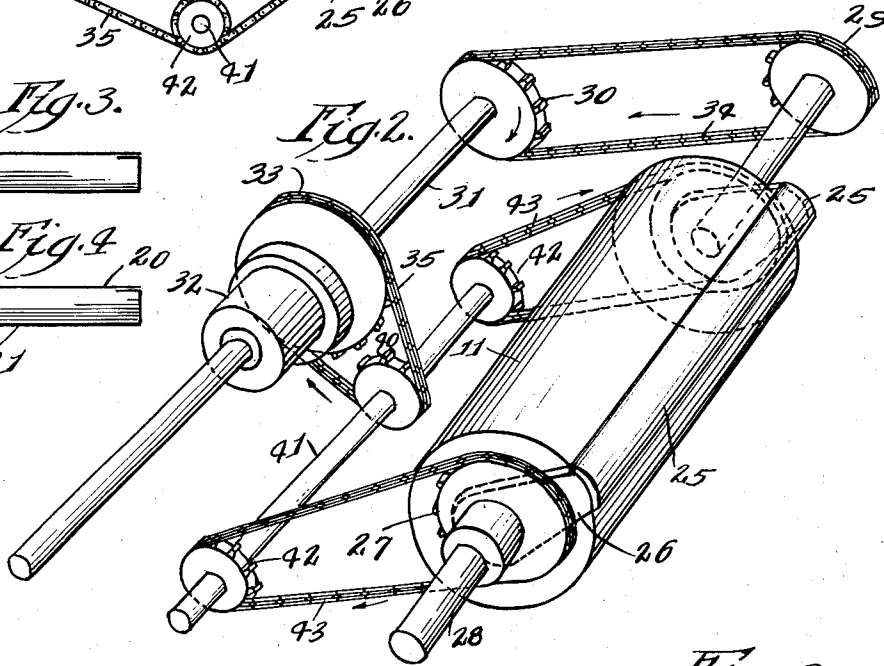
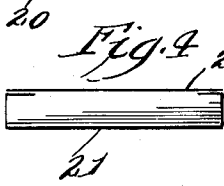
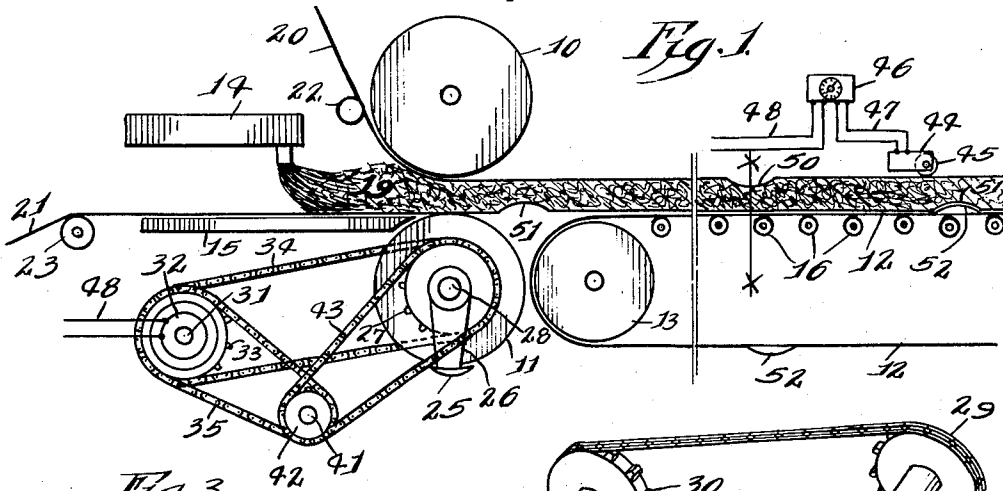

Inventor.
Ted E. Armstrong.
By. *Edw. A. Hampson*
Attorney.

1

2,991,826

GYPSUM WALLBOARD

Ted E. Armstrong, Park Ridge, Ill., assignor to The Celotex Corporation, Chicago, Ill., a corporation of Delaware

Filed Sept. 11, 1957, Ser. No. 683,418
9 Claims. (Cl. 154-1.25)

The inventions hereof are with reference to the production of gypsum wallboard having face recesses at its end edges. Boards of such construction are desirable so that where such gypsum wallboards abut end to end, the joint between the boards may be covered by taping to provide a smooth, continuous exposed wall surface. This joint taping is conventional, involving adhesively securing a strip of joint tape over the joint between adjacent boards with the subsequent application of a suitable joint cement to cover the tape and bring the surface over the joint to the plane of the major face areas of the boards.

The inventions hereof comprehend both the apparatus for producing gypsum wallboard having face recesses provided at the board ends and the method of producing such recessed wallboard.

Basically the gypsum wallboard hereof is produced in a conventional manner as comprising a gypsum core encased in a paper casing comprising the board faces. The board is produced on machines normally of four feet in width and as a continuous sheet which, after the gypsum core sets, is cut to length and dried to comprise the finished product.

The particular object of the inventions hereof is the provision of constructions in associated with a conventional apparatus for the production of gypsum wallboard to provide face recesses at the end edges of the finished wallboards. A further object of the inventions hereof is the provision of a method for producing gypsum wallboard having face recesses at the respective ends thereof. Other and additional objects of the inventions hereof will be apparent upon reading the following description of the apparatus and method as disclosed, particularly when read in conjunction with the accompanying drawings.

The apparatus and procedure or methods of the inventions hereof are susceptible of utilization in various arrangements and combinations, and whereas a preferred apparatus and method of production will be particularly disclosed and described, it is to be understood that variations thereof will be readily apparent to those skilled in the art to which the inventions appertain. Various of such alternatives will be briefly referred to in the following specification, but it is to be understood that the specific disclosure hereof and reference to such variants are to be considered as by way of explanation only and not in limitation of the utilization of the inventions hereof.

In the accompanying drawings, which are schematic or diagrammatic for the purpose of clearness of illustration,

FIGURE 1 is a side elevation of a gypsum wallboard apparatus;

FIGURE 2 is a detail of the drive actuating the mold strip mechanism;

FIGURES 3 and 4 show arrangements of the paper facings of the wallboard;

FIGURE 5 is a fragmentary perspective of a corner of a wallboard; and

FIGURE 6 is a detail of attachment of a mold strip to the setting belt.

The basic apparatus for the production of gypsum wallboard is well known to all those skilled in the art. It is to be understood that in connection with the diagrammatic showing of the apparatus for producing gypsum wallboard that the conventional drives, base supports and the like, are omitted for the sake of clearness of illustration.

The basic apparatus for producing gypsum wallboard

2

comprises spaced master rolls 10 and 11 between which the board is formed. The axes of these master rolls are, of course, mounted so as to provide proper spacing between the rolls for the formation of the desired gypsum wallboard, and they are mounted vertically or substantially vertically one above the other with their axes parallel. Board formed between the master rolls issues therefrom onto a setting conveyer 12 which is shown as passing around the belt roll 13. The formed board while on the conveyer belt sets and thereupon the continuously formed sheet is cut by a suitably mounted cutter to divide the continuously formed sheet into wallboard of appropriate lengths. The upper run of the setting conveyer is suitably supported by rolls 16.

Ahead of the master rolls, or on the other side thereof from that side on which the setting conveyer is positioned, there is provided plate 15 which will be referred to as a "forming" plate. Above forming plate 15 there is positioned a suitable mixer in which the gypsum slurry for the core of the board is mixed and from which it is discharged onto a paper facing 21, hereinafter referred to in more detail. The gypsum slurry from mixer 14 discharges onto paper cover sheet 21 which may be trained over roll 23, and a second cover sheet 20 feeds down over directing roll 22 to comprise the other face of the formed board. These cover sheets 20 and 21 together with the gypsum slurry deposited therebetween pass between master rolls 10 and 11 where the gypsum board of the desired thickness and width is formed as a continuous operation and constituting a continuous so formed board. It is, of course, understood by those skilled in the art that bottom cover sheet 21 is suitably scored adjacent its side edges, and that as this sheet feeds through the master rolls the edges are folded or directed vertically upwardly with the extreme edges retroverted, and that the edges of cover sheet 20 are adhesively secured to the retroverted extreme edge portions of the cover sheet 21.

The foregoing is merely given as a brief, general description of the, so far as is known, universally employed machine for producing gypsum wallboard as used by all commercial manufacturers. Also, so far as is known, all gypsum wallboard manufactured, at least in the United States, is formed with the bottom cover sheet 21 constituting the exposed face of the finished board with cover sheet 20 constituting the back face of the board. For the purposes hereof, in certain forms of the utilization of the inventions hereof, it is preferred that the board be formed with a face constituted by cover sheet 20 and its back constituted by cover sheet 21. This alternative relationship of the cover sheets is diagrammatically illustrated in FIGURES 3 and 4, wherein the face sheet 20 is that, the edges of which are turned upwardly and retroverted with the back face applied thereto, and FIGURE 4 shows the opposite, that is, the back sheet is the one of the edges which are so deformed and to the retroverted edges of which face sheet 20 is applied. These illustrations, FIGURES 3 and 4, are positioned so that the cover sheets are in accordance with their positioning in the procedure of manufacturing the board according to the alternative procedures referred to. When the board is manufactured according to the procedures of the apparatus, as illustrated in FIGURE 1 the face sheet of the finished board may be either the top sheet 20, as shown being fed into the apparatus in the drawing, or alternatively the relationship of the sheets 20 and 21 may be reversed and the face sheet 20 may be fed to the machine as the bottom sheet with the back sheet 21 feeding into the machine as the top sheet. The alternative manufacturing procedures involved will now be described.

We will first assume that the composite wallboard is to be manufactured with the face sheet 20 being fed to the machine as illustrated so that the board is made with

3

the face sheet up, as in FIGURE 4. For this manufacturing procedure the mold strips 52, to be subsequently more particularly referred to, are removed from setting belt 12. It is, of course, understood that cover sheets 20 and 21 are fed to the machine as illustrated, that the edge portions of sheet 21 are folded, as has been described, the gypsum slurry is deposited thereon as at 19, and the face sheet 20 is adhered to the retroverted edges of sheet 21. Suitable apparatus is provided for driving mold strip 25 mounted on arm 26 at the same speed as the speed of rotations of master roll 11. The apparatus for so driving mold strip 25 will be subsequently described in detail. However, assuming the drive mechanism for mold strip 25 to have been properly activated, it will in effect rotate with master roll 11 so as to mold in the bottom face of the composite board, as it is being formed between master rolls 10 and 11, a conforming recess which is the obverse of the configuration of mold strip 25. At this time, and for a subsequent period, the formed board is extremely soft and plastic, particularly as the face sheets 20 and 21 are more or less moistened by moisture from the slurry core. It will be understood, of course, with the continued rotation of mold strip 25, that upon completion of substantially a 360° travel thereof it will be deactivated and will remain in its deactivated position until it is again activated to mold a succeeding recess in the bottom face of the composite sheet as determined by the length of the wallboards being produced.

The composite sheet being extremely soft and plastic, after it issues from between master rolls 10 and 11, will, as soon as it passes from between the master rolls, begin to sag or settle through that portion wherein it has been thinned by the recess-forming action just above referred to. By the time the recessed portion passes on to the setting conveyer, or very shortly thereafter, that portion where the recess was molded in the bottom face of the composite sheet will have settled or sunk downwardly to the extent that it is supported on the setting belt in the plane of the contiguous portions of the bottom face of the composite board. Due to the fact that the core at such position is thinner than the contiguous portions of the core, due to the recess molding operation as described, it will follow that settlement or sinking of this portion will cause a commensurate settling or sinking at the top surface of the still plastic composite to form a recess in the top surface of the board, which recess is the obverse of the recess originally molded in the bottom face of the board between the master rolls. This action provides in the top face of the composite sheet a recess 50 extending across the width of the board and which, as has been referred to according to the particular procedure of manufacture, is the face sheet 20 of the finished wallboard in accordance with FIGURE 4.

If it is desired to manufacture the board with the face sheet down, in accordance with the diagram of FIGURE 3, then cover sheets 20 and 21 as fed to the machine are reversed in position, with sheet 20 then being the bottom sheet as it is being fed to the machine and sheet 21 the top sheet. For this condition mold strips 52 are mounted to the setting conveyer 12, it being understood, of course, that they are spaced thereon in accordance with the length of finished wallboard to be produced. Of course, the basic steps of manufacture do not change. The edges of sheet 20 are folded up, as described, the slurry is deposited thereon, and sheet 21 is adhered to the retroverted edges of sheet 20. Mold strip 25 is caused to rotate with the rotation of master roll 11 and a recess is molded in the bottom face of the composite sheet as it is being formed in the master rolls. As the formed composite sheet proceeds from the master rolls the recessed portion will, of course, settle or sink somewhat, as just previously described, but before this action is completed the thin molded portion of the board will be moving onto the setting conveyer. Molding strips 52 thereon, being properly positioned, will come into posi-

4

tion under the molded portion of the composite board and will support the board over the molded area to prevent further sinking or settling of this portion of the board. It is very likely that the soft, plastic board at the molded portion will have settled somewhat by the time that molding strip 52 is positioned thereunder and, of course, in such case, the effect of this positioning of molding strip 52 thereunder will be to reform the molded recess back to its original molded shape, the effect of which, of course, will be that the top cover sheet opposite the molded recess will be retained in the plane of the top surface of the board as it is being produced. Of course, as the board proceeds on setting conveyer 12 with the recessed portion supported by mold strip 52, it will be set so that by the time the board reaches the end of the setting conveyer it is self supporting and will have suitably spaced recesses in the bottom face thereof, which is the face sheet of the finished board.

From the foregoing it should be obvious to those skilled in the art that the molding strip 25 and associated activating and operating apparatus may be mounted to master roll 10 rather than to master roll 11, if such is deemed desirable or advantageous. The operation, of course, will be just the same as above described except that initially the composite, as it is being formed between master rolls 10 and 11, will be provided with the molded recess in its top surface where it may be retained or, if desired, may be caused to transfer to form an obverse recess in the bottom face of the composite board, which recess will be suitably remolded and supported by mold strips 52 on setting conveyer 12.

The activation of and drive for mold strip 25 is diagrammatically illustrated in FIGURE 2. It will be seen that mold strip 25 extends across the width of master roll 11 and that at its ends it is mounted to arms 26 which are suitably and freely mounted or journaled on shaft 28 of the master roll. Sprockets 27, also freely revolving on shaft 28, are mounted to arms 26 of the mold strip assembly and such constitute the final drive for revolving molding strip 25 on the axis of master roll 11, shaft 28, and at the same speed of rotation as will be apparent from the following description.

For driving molding strip 25 intermittently in properly timed relation, as above referred to, there is provided a clutch shaft 31 which is driven by sprocket 30 mounted thereon in turn driven by chain 34 at the same speed as that of shaft 28 by means of a sprocket 29 mounted on shaft 28.

Also mounted on clutch shaft 31 there is provided a clutch mechanism 32 which is secured to shaft 31. Adjacent to clutch 32 and revolving freely on shaft 31 there is provided a sprocket 33 which is intermittently clutched to clutch 32 to be driven at the speed of rotation of shaft 31 which, as referred to, rotates at the same speed as shaft 28.

Clutch 32 is a conventional "Hilliard single revolution clutch" and it will, of course, be understood that any equivalent clutch may be substituted. The particular clutch is available from the Frank W. Yarlino and Company of Chicago, Illinois. This particular clutch is solenoid-activated and is so constructed that in this particular use sprocket 33 is clutched to shaft 31 to make one revolution therewith, whereupon the clutch automatically disengages and is inactivated until again activated by action of the activating solenoid. This type of clutch being an article of commerce, it is deemed that a specific description thereof may be omitted.

A jack shaft 41 is suitably mounted between clutch shaft 31 and master roll shaft 28. There is mounted on jack shaft 41 a sprocket 40 which will be termed the "driven" sprocket and sprocket 42 which will be termed the "driving" sprocket. Driven sprocket 40 is driven from sprocket 33 by chain 35 and sprockets 27, which cause rotation of the mold strip assembly 25 and 26, are driven from driving sprockets 42 by chains 43.

It has been stated that clutch shaft 31 is driven at the same speed as master roll shaft 28. Since it is desired that the rotation of mold strip 25 shall be at the same rate as that of master roll 11, with which it is associated, it follows that the teeth of sprockets 33 and 27 are of the same number and that the teeth of sprockets 40 and 42 are all of the same number, whereby rotation of sprocket 32 at the speed of shaft 28 will cause rotation of the mold strip assembly at the same speed.

From the foregoing it should be readily obvious that when clutch 32 is activated at the proper controlled instant, that through the various sprockets and chains referred to the mold strip 25 and its associated parts will be caused to rotate in unison with the rotation of master roll 11, and that upon the completion of one revolution, due to the automatic feature of clutch 32, the drive of the mold strip 25 will be deactivated and will remain so deactivated until at the proper succeeding interval clutch 32 is reactivated.

There will now be described the device for activating clutch 32 at suitable reoccurrent intervals to result in the rotation of mold strip 25 in unison with the rotation of master roll 11 at uniformly reoccurrent intervals to provide the desired molded recesses, uniformly spaced in the composite board as it is being formed. For such purpose a lineal measurement actuating switch is suitably mounted over the formed board on setting conveyer 12. It will, of course, be understood that this device is mounted at a suitable distance along setting conveyer 12, which will be well along the length thereof since as it is driven from the surface of the formed board it must be mounted a sufficient distance down the conveyer so that the board core 19 may have set sufficiently so that the contacting wheel of the device will not deform the board. This lineal measurement actuating switch is a commercially available device such as that available from Production Instrument Company of 710 West Jackson Boulevard, Chicago, Illinois, and identified as their "Lineal Measurement Actuating Switch ES-113." This device includes a friction wheel 45 which contacts the surface of the formed composite board and is driven thereby. This lineal measurement device is generally identified in the drawing by numeral 44. Each revolution of wheel 45 through connecting conductor 47 sends an electrical impulse to a device 46 which conventionally is a commercially available product of the Eagle Signal Corporation of Moline, Illinois, identified as their "Microflex Reset Counter."

The microflex reset counter is a device which can be set to count impulses received from the lineal measurement actuating switch 44 and having received a pre-set number of such impulses to in turn supply an actuating impulse through conductors 48 to the solenoid actuator of the clutch 32. Device 46, upon sending an impulse to clutch 32, automatically resets and repeats its operation.

It will be seen that the advance of the composite formed board on setting conveyer 12 will cause rotation of friction wheel 45 resting on the top surface thereof to supply electrical impulses to the reset counter 46. Assuming the circumference of wheel 45 to be four inches, an impulse will be supplied by device 44 for each four-inch travel of the board on the conveyer 12. If eight-foot wallboards are to be produced then the reset counter 46 will be set to supply an impulse on its receipt of the thirty-second impulse from lineal measurement switch 44 for activation of clutch 32. It will, of course, be understood that by suitable setting of reset counter 46 an actuating impulse may be impressed on clutch mechanism 32 for any desired travel of the composite formed board as it is being carried on setting conveyer 12. Assuming that the actuating devices have been set for supplying an impulse to clutch 32 for each eight-foot of travel of the formed board, then obviously for each eight feet of travel of the composite formed board, clutch 32 will be activated to cause mold strip 25 to rotate with master roll 11 to mold a recess in the bottom face of the composite board at eight-foot

intervals as the board is being formed between the master rolls 10 and 11.

After the composite wallboard has been formed and has set on setting conveyer 12, it is suitably severed into lengths by a suitably actuated knife operating to sever the continuously produced sheet medially of recess 50, as on line XX of FIGURE 1. After the composite board has been formed with recesses spaced eight feet apart it will, of course, follow that severance medially of such recesses will result in the production of wallboards which are eight feet in length. The individual wallboards so severed then follow the usual procedure of the manufacture of gypsum wallboard, passing into a drier with or without turning as dictated by circumstances, and when such issue from the drier they are finished gypsum wallboards of uniform length provided with face recesses at their opposite ends.

Summarizing the operation of the apparatus as above described, gypsum wallboards of uniform length may be produced which have face recesses at their opposite ends. In this procedure of manufacture the cover sheets with interposed gypsum slurry pass between suitably spaced master rolls which form the elements into the composite board in which, as the elements are so formed, suitable recesses are molded into a face thereof to provide, when the such sheet is severed medially of such recesses, the desired end recessed gypsum wallboards. This continuously formed composite board may, as described, have the recess formed in either face and retained therein, although if the recess is to be retained in the bottom face of the board as formed it would be necessary that such molded recess be reformed and supported by mold strips extending across the width of the setting conveyer. It has been described that the composite board may be formed with the face sheet either down, that is on the lower side as the composite board is formed, or with the face sheet up, or on the upper surface as the composite board is being formed. Additionally, it has been described that the devices for molding the recess in the board surface may be associated either with the bottom master roll 11 or, if circumstances so dictate or it is desired, such may be associated with the top master roll 10. Boards of different lengths may be produced by suitable setting of the control devices, the lineal measurement actuating switch 44 and the microflex reset counter 46, so that the recesses may be reoccurrently formed in the composite board as the board is being formed with such recesses uniformly spaced according to the predetermined spacing for which the control devices have been set, and consequently end recessed boards of different lengths as desired may be produced.

In case it may be desired to produce wallboards of different lengths, by way of example, say, of eight-foot lengths in one case and ten-foot lengths in another, then mold strips 52 should be removably mounted to setting conveyer 12. For such purpose snap connectors may be employed with one element thereof, such as 53, mounted to setting conveyer 12 and with the other element 54 thereof mounted to mold strips 52. By suitable mounting of the snap connector elements 53 suitably positioned on setting conveyer 12 it will be apparent that mold strips 52, if, for example, applied at eight-foot intervals, may be removed and reapplied at ten-foot intervals on setting conveyer 12, and thus such will conform to a ten-foot original molding of the recesses in the board as such is being formed.

The inventions hereof and the operation thereof having been described in detail, I claim:

1. In a gypsum wallboard producing apparatus comprising essentially, vertically spaced master rolls, shafts mounting the master rolls and a setting conveyer, the improvement for forming a recess in said gypsum wallboard comprising a molding strip extending transversely across the width of a master roll, a journaled arm, the arm journaled on the axis of the master roll shaft and

7

at its other end mounting the molding strip and drive means driving the journaled arm in a circular path.

2. In the apparatus of claim 1, a clutch member comprising an element of the journaled arm drive means and disengageable to disconnect the drive for the journaled arm.

3. In the apparatus of claim 2, the drive means comprising a clutch shaft, a clutch secured to the clutch shaft and a sprocket journaled on the clutch shaft and drivingly engageable with the clutch shaft through the intermediary of the clutch.

4. In the apparatus of claim 1, wherein a journaled arm and the drive means therefor are journaled on the master roll shaft adjacent each of the ends of the master roll and connected respectively to the ends of the molding strip.

5. In the apparatus of claim 1, wherein a journaled arm and the drive means therefor are journaled on the master roll shaft adjacent each of the ends of the master roll and connected respectively to the ends of the molding strip, driving means driving the drive means driving the journaled arms comprising a clutch shaft, a clutch secured to the clutch shaft and a sprocket journaled on the clutch shaft and drivingly engageable with the clutch shaft through the intermediary of the clutch, an associated jack shaft, sprockets thereon, a driving member driven by the sprocket journaled on the clutch shaft and driving the jack shaft, driving members driven by the jack shaft and driving the molding strip assembly of molding strip, arms therefor and driving means therefor and means driven by the master roll shaft and driving the clutch shaft.

6. In a machine for the manufacture of gypsum wallboard and including a master roll mounted on a shaft, a molding strip extending across the width thereof for forming a recess in said gypsum wallboard and means revolving the molding strip to prescribe the surface of a cylinder of revolution substantially in contact with the surface of the master roll.

8

7. In the apparatus of claim 6, means driven from the shaft of the master roll and driving the molding strip to prescribe a surface of revolution substantially in contact with the surface of the master roll, the master roll and molding strip rotating in unison.

8. In the apparatus of claim 6, means driven from the shaft of the master roll and driving the molding strip to prescribe a surface of revolution substantially in contact with the surface of the master roll, the master roll and molding strip rotating in unison, the means driving the molding strip comprising a clutch and means intermittently activating the clutch at uniform predetermined intervals.

9. In the apparatus of claim 6, means driven from the shaft of the master roll and driving the molding strip to prescribe a surface of revolution substantially in contact with the surface of the master roll, the master roll and molding strip rotating in unison, the means driving the molding strip comprising a clutch and means intermittently activating the clutch at uniform predetermined intervals, and lineal measurement means initiating activation of the clutch.

References Cited in the file of this patent

UNITED STATES PATENTS

2,044,234	Walper	June 16, 1936
2,090,084	Walper	Aug. 17, 1937
2,168,803	Page	Aug. 8, 1939
2,238,017	Duncan	Apr. 8, 1941
2,246,987	Roos	June 24, 1941
2,537,509	Camp	Jan. 9, 1951
2,679,215	Truesdell	May 25, 1954

FOREIGN PATENTS

440,064	Great Britain	Dec. 19, 1935
872,025	Germany	Mar. 30, 1953