



(11) **EP 2 042 642 A2**

(12) **EUROPEAN PATENT APPLICATION**

(43) Date of publication:  
**01.04.2009 Bulletin 2009/14**

(51) Int Cl.:  
**D06F 58/04 (2006.01)**

(21) Application number: **08105424.9**

(22) Date of filing: **24.09.2008**

(84) Designated Contracting States:  
**AT BE BG CH CY CZ DE DK EE ES FI FR GB GR HR HU IE IS IT LI LT LU LV MC MT NL NO PL PT RO SE SI SK TR**  
Designated Extension States:  
**AL BA MK RS**

(71) Applicant: **BSH Bosch und Siemens Hausgeräte GmbH**  
**81739 München (DE)**

(72) Inventor: **Wan, Xiu**  
**100046 Nanjing Jiangsu (CN)**

(30) Priority: **28.09.2007 CN 200710133303**

(54) **Drying support for laundry drying device**

(57) A drying support for a laundry drying device is disclosed, which drying support is a substantially quadrate foldable member with a certain thickness, and its longitudinal length  $S$  is less than or equal to the length in the axial direction of a drum of the laundry drying device; its minimum transverse length  $L_{min}$  after being folded is less than or equal to the inner diameter  $d$  of an entry opening on the laundry drying device, and its maximum

transverse length  $L_{max}$  after being unfolded is less than or equal to the inner diameter  $D$  of the drum; when in use, the drying support is put inside the drum which stays still. When a user operates it, he or she directly puts the drying support inside the drum via the entry opening, unfolds the drying support, then lays the laundry to be dried above the drying support, and starts a drying program of the drying device, therefore the operation is very convenient.

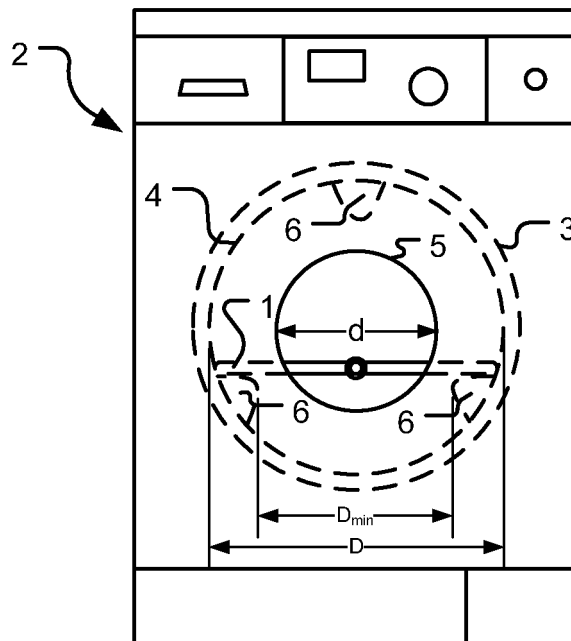

Fig.3

EP 2 042 642 A2

## Description

### Technical field

**[0001]** The present invention relates to a drying support for assisting a laundry drying device to dry the laundry.

### Background art

**[0002]** Commonly a laundry drying device can be a drum-type washer-dryer or a drum-type drying machine, and hereinbelow the drum-type washer-dryer is taken as an example. The drum-type washer-dryer comprises a water tub and a rotatable drum disposed inside the water tub; a heating assembly is disposed on the upper side of the water tub; the heating assembly comprises a heater and a heating channel, and an outlet of the heating channel is in communication with the interior of the water tub and the drum. The drying process thereof is as follows: Air is heated by the heater into dry hot air which is transferred to the interior of the drum via the heating channel; the drum rotates at high speed under the drive of a motor, thereby driving the laundry to tumble up and down and have full contact with the dry hot air; a heat exchange occurs between the dry hot air and the laundry inside the drum such that the moisture in the laundry is carried by the air which thereby becomes relatively humid; a condensing assembly is disposed at a suitable place on one side of the water tub, and the condensing assembly comprises a condensing pipeline and a condensing device; an inlet of the condensing pipeline is in communication with the water tub, and an outlet thereof is in communication with an inlet of the heating channel; and the heating channel, the water tub, the drum and the condensing pipeline form an air circulating loop. In order to promote the air circulation, an air-blasting device are generally disposed between the condensing device and the heater; the air-blasting device generally includes a fan and a motor for driving the fan to rotate. Under the effects of the fan, the humid air formed after the heat exchange enters into the condensing pipeline via the inlet of the condensing pipeline; by way of the condensing effect of the condensing device, the moisture in the humid air is condensed, and then it reenters into the heating channel of the heating assembly and is heated again by the heater and transferred to the drum; and following a plurality of cycles, the moisture in the laundry is dried gradually.

**[0003]** However, the above drying process has the following problems. First, during the drying process, since the drum's high speed rotation will drive the laundry to rotate with the drum, and when rotating at low speed, the laundry will be tumbling up and down inside the drum, therefore, the laundry is inevitably wrinkled or tangled, therefore, it is impossible for dry hot air to effectively enter the tangled laundry, thereby makes it difficult for the laundry in the centre to be dried, while if the laundry in the centre is dried to an ideal degree by increasing the drying

time or other mode, outside portion of the laundry will often be over dried. Obviously, both the wrinkles and over-drying would result in damages to the laundry. Furthermore, when the laundry is dried to a certain degree, there exists a possibility that the laundry may be ignited due to the high temperature inside the drum and the effect of heater, thereby causing greater damage. Especially in cases when some delicate fabrics made from silk or animal wool (such as sheep wool, cashmere) are dried, the above risk is increased. In addition, sometimes when some special articles are dried, such as sport shoes and so on, the rotation of the drum will actually reduce the drying effect. And in other conditions, the laundry needs to be dried just because it gets damped, while such laundry is usually folded, and a user does not wish to fold the laundry again after it has been dried.

### Contents of the invention

**[0004]** In view of the above problems, an object of the present invention is to provide a drying support for assisting a laundry drying device to dry the laundry. By using the drying support, damages to the laundry, especially to delicate fabrics, caused by a drying device during the drying process can be effectively reduced, and at the same time the drying effect of the laundry can be ensured effectively and, furthermore, the operation process for a user to dry laundry can be simplified.

**[0005]** In order to realize the above object of the present invention, the drying support for a laundry drying device is realized as follows: A drying support for a laundry drying device, the laundry drying device comprising a water tub, a rotatable drum disposed inside the water tub, and a laundry entry opening for a user to access the laundry disposed on the front end of the drum, and at least two lifting device disposed along the radial direction inside the drum; wherein the drying support is a substantially quadrate and foldable member with a certain thickness, longitudinal length  $S$  of which is less than or equal to an axial length of the drum; and minimum transverse length  $L_{\min}$  of which after being folded is less than or equal to the inner diameter  $d$  of the entry opening  $d$ , and maximum transverse length  $L_{\max}$  of which after being unfolded is less than or equal to the inner diameter  $D$  of the drum; and when in use, the drying support is positioned within the drum which stays still. During operation, the drying support is put into inside of the drum via the entry opening, unfolded, and substantially parallel positioned, then the laundry to be dried is laid on the drying support, and a drying program of the drying device is started. On one hand, because the drum is still without rotating, the laundry will not be tumbled or tangled, thereby abrasion of the laundry caused during the drying process is reduced, and at the same time, contacting area between the laundry and the dry hot air can be greatly increased by laying the laundry spread out, so as to ensure the drying effects of the laundry more effectively. On the other hand, since the drum is still, the noise gen-

erated by the drying device is significantly reduced.

**[0006]** As a preferred embodiment of the present invention, the transverse length  $L_{max}$  of the drying support after being unfolded is greater than or equal to the shortest distance  $D_{min}$  between the two adjacent lifting devices, and is less than or equal to the inner diameter  $D$  of the drum. Preferably, when in use, the drying support is disposed on the two adjacent lifting devices, and in this case, the two adjacent lifting device are positioned on a same horizontal plane. Supported by the lifting devices, the drying support is available for supporting more drying laundries, and deformation of the drum by excessive weight of the laundry is avoided.

**[0007]** Preferably, the drying support is air-permeable. Thus, the dry hot air may flows through the drying support after heat exchange, and also it increase drying effect of contacting area between the laundry and the drying support.

**[0008]** Preferably, the drying support is reticulated or a plate structure formed with a plurality of through-holes. Such a drying support is simpler, and at the same time is stronger, and it provides the possibility for a user to put in more laundry.

**[0009]** More preferably, the drying support comprises a first member and a second member, and the first and second members are connected by a hinge, and by way of a positioning device the first member is made to have a maximum rotation angle of  $180^\circ$  relative to the second member. By way of the connection by the hinge, the disadvantage that the drying support cannot enter the interior of the drum because of small diameter of the entry opening is overcome, and at the same time the user can adjust the rotation angle between the first member and second member by the positioning device as required, so as to adjust the overall length of the drying support in the transverse direction to adapt itself to drums with different inner diameters.

**[0010]** Furthermore, the drying support for a laundry drying device can also be realized as follows: a drying support for a laundry drying device, wherein the laundry drying device comprises a water tub and a rotatable drum disposed inside the water tub, a laundry entry opening for a user to access the laundry disposed on the front end of the drum, and at least two lifting device disposed along the radial direction inside the drum; wherein the drying support is extensible in the transverse direction, and longitudinal length  $S$  of which is less than or equal to the length of the drum in the axial direction; and minimum transverse length  $L_{min}$  of which after being retracted is less than or equal to the inner diameter  $d$  of the entry opening, and maximum transverse length  $L_{max}$  of which after being extended is less than or equal to the inner diameter  $D$  of the drum; when in use, the drying support is positioned within the drum which is still. With such an extensible structure, to put the drying support into the drum, the drying support can be retracted to pass through the entry opening; after being put into the drum, the drying support can be pulled out in the opposite di-

rection, so as to dispose the drying support inside the drum, and then the laundry to be dried is placed on the drying support and finally a drying program is started. It is not difficult to understand that, such an extensible drying support has substantially the same functions realized by the foldable drying support of the embodiment of the present invention, and therefore, it can similarly solve the technical problem which the present invention intends to solve.

**[0011]** As a preferable embodiment of the present invention, when in use, the drying support is disposed on the two adjacent lifting devices which are positioned on a same horizontal plane.

**[0012]** Preferably, the drying support is of a grid structure, which comprises a plurality of bars parallel to and spaced apart at a certain distance from one another, wherein each of the bars comprises two relative sliding or telescoping portions, and the transverse length of the bars is adjusted by a positioning device, thereby users may adjust the overall length of the drying support in the transverse direction according to different diameters of the drums or different needs by the users.

**[0013]** More preferably, in order to prevent deformation of the drum caused by excessive laundry loaded on the drying support, surfaces of two sides of the drying support that contacting the drum have a curvature is in conformity with a curvature of the drum at where the surfaces contact the drum.

Description of the drawings

**[0014]** The present invention will be further described hereinbelow in combination with the drawings and embodiments.

Fig. 1 is a schematic view of a foldable drying support for a laundry drying device;

Fig. 2 is a schematic view of an extendable drying support for a laundry drying device;

Fig. 3 is a schematic diagram of a laundry drying device using a foldable drying support.

Embodiments

**[0015]** Fig. 1 shows a foldable drying support 1 for a laundry drying device according to an embodiment of the present invention. As shown in the figure, the drying support 1 comprises a first member 7 and a second member 8, and the first member 7 and second member 8 are connected by a hinge 9 and can pivot about the hinge 9 in a plane perpendicular to the hinge 9, so that the first member 7 and second member 8 can be folded together or unfolded. A positioning device 10 is disposed at a position where the first member 7 and second member 8 are connected, the pivot angle of the first member 7 and second member 8 can be adjusted and they can be fixed at a certain angle, thereby overall length of the drying support 1 in the transverse direction is adjustable. Pref-

erably, the drying support 1 is air-permeable between its upper and lower sides, so as to ensure air above the drying support 1 to flow therethrough to the lower side of the drying support 1. More preferably, the drying support 1 is reticulated or a plate structure with a plurality of through-holes, and therefore ensure the required strength for supporting the laundry.

**[0016]** Fig. 2 shows an extendable drying support 11 for a laundry drying device according to another embodiment of the present invention. Relative to the foldable structure of the drying support 1 as shown in Fig. 1, the differences of the extendable drying support 11 are that: the overall length of the drying support 11 in the transverse direction can be adjusted by extension. Preferably, the extendable drying support 11 is of a grid, which comprises a plurality of bars 12 parallel to each other, and the bars 12 are spaced apart from one another at a certain distance; more preferably, the bars 12 are evenly distributed in the longitudinal direction, thereby to evenly bear the force. Each of the bars 12 comprises two relative sliding or telescoping portions, and the transverse length of the bars 12 is adjustable by way of the positioning device 13, so as to obtain different lengths.

**[0017]** The laundry drying device 2 using the above foldable drying support 1 will be described hereinbelow by reference to Fig. 3 and in combination with Fig. 1, and to make it clearer, a door assembly of the laundry drying device 2 is omitted in the figure.

**[0018]** As shown in the figure, the laundry drying device 2 comprises a water tub 3 and a rotatable drum 4 disposed inside the water tub 3; a laundry entry opening 5 for a user to access the laundry is disposed on the front end of the drum 4; at least two lifting devices 6 are disposed along the radial direction inside the drum 4, and normally three lifting devices 6 are distributed evenly along the circumferential direction of the drum 4. When the foldable drying support 1 as shown in Fig. 1 is used, in order to ensure that the drying support 1 can be placed inside the drum 4 through the laundry entry opening 5, longitudinal length  $S$  of the drying support 1 is less than axial length of the drum 4, and at the same time, when the drying support 1 is folded, its minimum transverse length  $L_{\min}$  is less than or equal to the inner diameter  $d$  of the entry opening 5; and after being unfolded, its maximum transverse length  $L_{\max}$  is less than or equal to the inner diameter  $D$  of the drum 4. In this way, when the drying support 1 is used for drying purposes, it is only needed to place the folded drying support 1 inside the drum 4 through the laundry entry opening 5, and then to unfold the first member 8 and the second member 9 of the drying support 1, so as to make two sides of the first member 8 and second member 9 against the drum 4. After the drying support 1 is substantially horizontally positioned, namely the first member 8 and second member 9 are substantially at a same horizontal plane, laundry is placed tidily on the drying support 1, and a drying program of the laundry drying device is started. Of course, a certain angle can also be formed between the first member

8 and the second member 9 by the positioning device 10, namely the first member 8 and the second member 9 are inclined to form two symmetrical inclined surfaces, so as to meet different requirements, such as drying a pair of sport shoes. Preferably, the maximum transverse length  $L_{\max}$  after the drying support 1 is unfolded is greater than or equal to the minimum distance  $D_{\min}$  between any two adjacent lifting devices 6, so that the drying support 1 can be placed directly on the two adjacent lifting devices 6 after it is unfolded, and by way of the extra supporting force provided by the lifting devices 6, it is possible to put more laundry onto the drying support 1. In addition, in order to prevent the laundry from sliding from the drying support 1 due to the rotation of the drum 4, and at the same time to prevent the laundry from tumbling and becoming tangled together due to the rotation of the drum 4, which causes incomplete drying, uneven drying, over-drying, or wrinkles, the drum 4 stays still in the drying program, i.e. the drum 4 does not rotate during the drying program. During the drying process, the heated hot air comes into contact with the laundry on the drying support 1 and heat exchange occurs, so the moisture in the laundry is carried by the hot air and humid air is formed, which is then discharged via the grids or through holes of the drying support 1 or holes on the wall of the drum 4, and then is condensed by a condensing device, so as to make the moisture contained in the humid air condensed; the air is inhaled under the effects of a fan into heating assembly to be heated again, and then enters the next cycle. After a number of such cycles, the drying process is finally accomplished.

**[0019]** Similar to the use of the foldable drying support 1, it is not difficult to understand that, when the extensible drying support 11 as shown in Fig. 2 is used, the drying support 11 is retracted, and then it is put inside the drum 4 via the entry opening 5 and extended in the opposite direction, so that the overall length of the drying support 11 in the transverse direction can be adjusted by the positioning device 13 according to different needs, and then the laundry is placed on the drying support 11, and the drying program of the laundry drying device 2 is started. In order to ensure that the drying support 11 can be readily placed inside the drum 4, the drying support 11 is designed in such a way that its minimum transverse length  $L_{\min}'$  in a contracted state is less than or equal to the inner diameter  $d$  of the entry opening, and its maximum transverse length  $L_{\max}'$  after being extended is less than or equal to the inner diameter  $D$  of the drum. Similarly, the functions and technical effects of such an extensible drying support 11 which can be realized in the embodiment of the present invention are substantially in conformity with aforementioned foldable drying support 1, and the difference is that, the dry hot air after heat exchanging is discharged via holes around the drum 4 and slots between the bars 12; apparently this is readily understood by those skilled in the art, and will not be further described herein.

**[0020]** Obviously, in the embodiments of the present

invention, either the foldable drying support 1 or the extensible drying support 11 is used, it is always convenient for a user to operate, and at the same time, when the user only wants to dry damp laundry (for example, in rainy weather or in an area with extreme humidity, the laundry will get damp after being stored for a long time), it is only need to place the laundry neatly on the drying support, and then start the drying program to dry it; after having been dried, the laundry is still stacked neatly, so there is no need for the user to re-fold the laundry.

**[0021]** In addition, in order to prevent deformation of the drum 4 caused by excessive laundry loaded on the drying support, surfaces of two sides of the drying support 1 or 11 that contacting the drum 4 have a curvature is in conformity with a curvature of the drum 4 at where the surfaces contact the drum.

**[0022]** It should be noted that, for the sake of clarity, the so-called "transverse direction" or "longitudinal direction" in the present invention are all relative terms, wherein "longitudinal direction" is a direction parallel to the rotation axis of the drum 4, while "transverse direction" is a horizontal direction perpendicular to the "longitudinal direction". The "transverse length" or "longitudinal length" of the drying support 1 or 11 is the length in use when the drying support 1 or 11 is placed inside the drum 4 relative to the above "transverse direction" or "longitudinal direction".

**[0023]** In summary, within the scope of the basic technical idea of the present invention, all forms of variations by those skilled in the art relevant to the technical field of the present invention as disclosed are within the protection scope of this patent application for the present invention.

## Claims

1. A drying support (1) for a laundry drying device (2), the laundry drying device (2) comprising a water tub (3), a rotatable drum (4) disposed inside the water tub (3); a laundry entry opening (5) for a user to access the laundry disposed on the front end of the drum (4), and at least two lifting devices (6) disposed along the radial direction inside the drum (4), **characterized in that** the drying support (1) is a substantially quadrate foldable member with a certain thickness, and has a longitudinal length S less than or equal to length of the drum (4) in the axial direction, has a minimum transverse length  $L_{min}$  after being folded less than or equal to an inner diameter d of the entry opening (5), and has a maximum transverse length  $L_{max}$  after being unfolded less than or equal to an inner diameter D of the drum (4); and when in use, the drying support (11) is put inside the drum (4) which stays still.
2. The drying support (1) as claimed in claim 1, **characterized in that** the transverse length  $L_{max}$  of the

drying support (1) after being unfolded is greater than or equal to the shortest distance  $D_{min}$  between two adjacent lifting devices (6) and is less than the inner diameter D of the drum (4).

3. The drying support (1) as claimed in claim 2, **characterized in that**, the drying support (1) is disposed on two adjacent lifting devices (6), the two adjacent lifting devices (6) are positioned on a same horizontal plane.
4. The drying support (1) as claimed in one of claims 1 to 3, **characterized in that** the drying support (1) is air-permeable.
5. The drying support (1) as claimed in claim 4, **characterized in that** the drying support (1) is reticulate or of a plate structure formed with a plurality of through-holes.
6. The drying support (1) as claimed in one of claims 1 to 5, **characterized in that** the drying support (1) comprises a first member (7) and a second member (8), and the first member (7) and second member (8) are connected by a hinge (9) and by way of positioning device (10) the first member (7) is made to have a maximum rotation angle of  $180^\circ$  relative to the second member (8).
7. A drying support (11) for a laundry drying device (2), the laundry drying device (2) comprising a water tub (3), a rotatable drum (4) disposed inside the water tub (3); a laundry entry opening (5) disposed on the front end of the drum (4) for a user to access the laundry, and at least two lifting devices (6) disposed along the radial direction inside the drum (4), **characterized in that** the drying support (11) is extensible in the transverse direction; has a longitudinal length S less than or equal to the length of the drum (4) in the axial direction; has a minimum transverse length  $L_{min}$  after retraction less than or equal to the inner diameter d of the entry opening (5), and has a maximum transverse length  $L_{max}$  after extension less than or equal to inner diameter D of the drum (4); and when in use, the drying support (11) is put inside the drum (4) which stays still.
8. The drying support (11) as claimed in claim 7, **characterized in that** the drying support (11) is disposed on two adjacent lifting devices (6), the two adjacent lifting devices (6) are positioned on a same horizontal plane.
9. The drying support (11) as claimed in claim 7 or 8, **characterized in that** the drying support (11) is of a grid structure, which comprises a plurality of bars (12) parallel to and spaced at a certain distance from one another, wherein each of the bars (12) compris-

es two sliding or telescoping portions, and the transverse length of the bars (12) is adjusted by a positioning device (13).

10. The drying support (1, 11) as claimed in one of claims 1 to 9, **characterized in that** surfaces of two sides of the drying support (1, 11) that contacts the drum have a curvature in conformity with a curvature of the drum (4) at where the surfaces contact the drum.

5

10

15

20

25

30

35

40

45

50

55

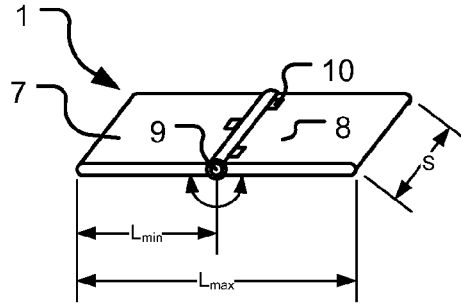

Fig.1

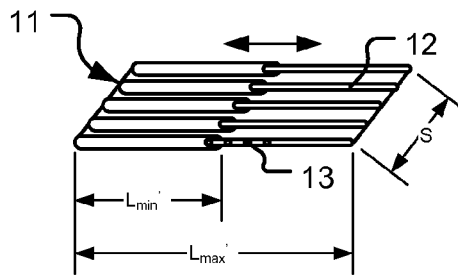

Fig.2

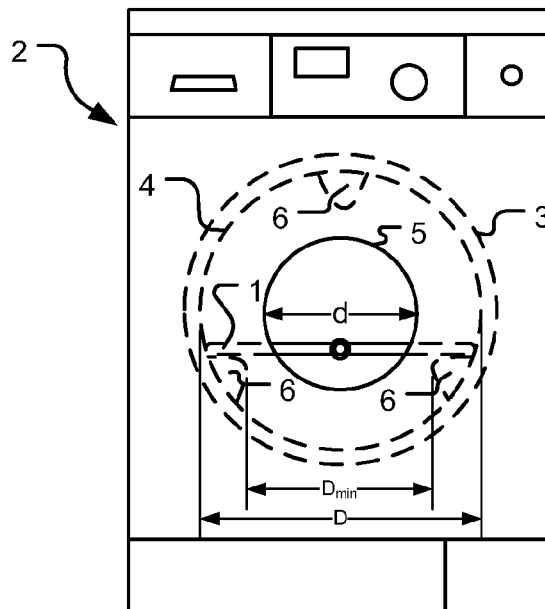

Fig.3