



US00D920402S

(12) **United States Design Patent**  
**Eitschberger**

(10) **Patent No.:** **US D920,402 S**

(45) **Date of Patent:** **\*\* May 25, 2021**

(54) **TANDEM SUB**

(71) Applicant: **DynaEnergetics Europe GmbH**,  
Troisdorf (DE)

(72) Inventor: **Christian Eitschberger**, Munich (DE)

(73) Assignee: **DynaEnergetics Europe GmbH**,  
Troisdorf (DE)

(\*\*) Term: **15 Years**

(21) Appl. No.: **29/762,191**

(22) Filed: **Dec. 15, 2020**

**Related U.S. Application Data**

(63) Continuation of application No. 29/733,325, filed on  
Apr. 30, 2020, now Pat. No. Des. 908,754.

(51) **LOC (13) Cl.** ..... **15-09**

(52) **U.S. Cl.**  
USPC ..... **D15/139**; D23/232

(58) **Field of Classification Search**  
USPC ..... D8/354, 358, 382; D12/197; D15/21,  
D15/126, 138, 139, 143; D2/100, 112;  
D23/259–260, 262, 264–266  
CPC ... E21B 43/117; E21B 43/119; E21B 43/1185  
See application file for complete search history.

(56) **References Cited**

**U.S. PATENT DOCUMENTS**

2,216,359 A 10/1940 Spencer  
2,358,466 A 9/1944 Miller  
2,418,486 A 4/1947 Smylie  
(Continued)

**FOREIGN PATENT DOCUMENTS**

CA 2821506 A1 1/2015  
CA 2824838 A1 2/2015  
(Continued)

**OTHER PUBLICATIONS**

State Intellectual Property Office, P.R. China; First Office Action for  
Chinese App No. 201580011132.7; dated Jun. 27, 2018; 5 pages  
(Eng. Translation 9 pages).

(Continued)

*Primary Examiner* — Patricia A Palasik

(74) *Attorney, Agent, or Firm* — Moyles IP, LLC

(57) **CLAIM**

I claim the ornamental design of a tandem sub, as shown and  
described.

**DESCRIPTION**

FIG. 1 is a front perspective view of a tandem sub showing  
an embodiment of our new design;

FIG. 2 is a rear perspective view of the tandem sub of FIG.  
1;

FIG. 3 is a top plan view of the tandem sub of FIG. 1;

FIG. 4 is a bottom plan view of the tandem sub of FIG. 1;

FIG. 5 is a left-side elevated view of the tandem sub of FIG.  
1;

FIG. 6 is a right-side elevated view of the tandem sub of  
FIG. 1;

FIG. 7 is a front elevated view of the tandem sub of FIG. 1;

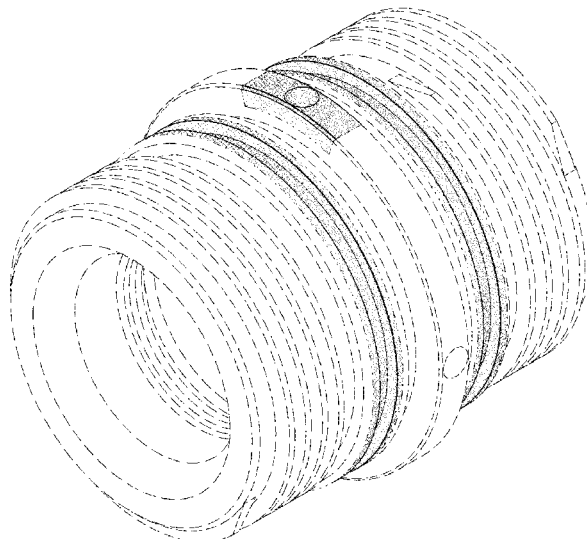
FIG. 8 is a rear elevated view of the tandem sub of FIG. 1;

FIG. 9 is a cross-section view of the tandem sub of FIG. 3  
along line 9-9; and,

FIG. 10 is a cross-section view of the tandem sub of FIG. 3  
along line 10-10.

The broken lines consisting of dashes show an environment  
that forms no part of the claimed design. The broken lines  
consisting of a double-dot/dash pattern show a boundary of  
the claimed design.

**1 Claim, 10 Drawing Sheets**



# US D920,402 S

(56)

## References Cited

### U.S. PATENT DOCUMENTS

2,889,775	A	6/1959	Owen	7,193,527	B2	3/2007	Hall	
3,158,680	A	11/1964	Lovitt et al.	7,278,491	B2	10/2007	Scott	
3,170,400	A	2/1965	Nelson	7,533,722	B2	5/2009	George et al.	
3,173,992	A	3/1965	Boop	7,568,429	B2	8/2009	Hummel et al.	
3,246,707	A	4/1966	Bell	7,591,212	B2	9/2009	Myers, Jr. et al.	
3,374,735	A	3/1968	Moore	7,661,474	B2	2/2010	Campbell et al.	
3,504,723	A	4/1970	Cushman et al.	7,762,172	B2	7/2010	Li et al.	
3,859,921	A	1/1975	Stephenson	7,762,351	B2	7/2010	Vidal	
4,007,790	A	2/1977	Henning	7,778,006	B2	8/2010	Stewart et al.	
4,007,796	A	2/1977	Boop	7,810,430	B2	10/2010	Chan et al.	
4,058,061	A	11/1977	Mansur, Jr. et al.	7,908,970	B1	3/2011	Jakaboski et al.	
4,100,978	A	7/1978	Boop	7,929,270	B2	4/2011	Hummel et al.	
4,182,216	A	1/1980	DeCaro	8,066,083	B2	11/2011	Hales et al.	
4,266,613	A	5/1981	Boop	8,069,789	B2	12/2011	Hummel et al.	
4,290,486	A	9/1981	Regalbuto	8,074,737	B2	12/2011	Hill et al.	
4,411,491	A	10/1983	Larkin et al.	8,079,296	B2	12/2011	Barton et al.	
4,491,185	A	1/1985	McClure	8,136,439	B2	3/2012	Bell	
4,496,008	A	1/1985	Pottier et al.	8,157,022	B2	4/2012	Bertoja et al.	
4,523,650	A	6/1985	Sehnert et al.	8,181,718	B2	5/2012	Burleson et al.	
4,574,892	A	3/1986	Grigar et al.	8,182,212	B2	5/2012	Parcell	
4,598,775	A	7/1986	Vann et al.	8,186,259	B2	5/2012	Burleson et al.	
4,619,333	A	10/1986	George	8,230,932	B2	7/2012	Ratcliffe et al.	
4,621,396	A	11/1986	Walker et al.	8,256,337	B2	9/2012	Hill	
4,650,009	A	3/1987	McClure et al.	8,336,437	B2	12/2012	Barlow et al.	
4,657,089	A	4/1987	Stout	8,395,878	B2	3/2013	Stewart et al.	
4,660,910	A	4/1987	Sharp et al.	8,451,137	B2	5/2013	Bonavides et al.	
4,744,424	A	5/1988	Lendermon et al.	8,469,087	B2	6/2013	Gray	
4,747,201	A	5/1988	Donovan et al.	8,661,978	B2	3/2014	Backhus et al.	
4,776,393	A	10/1988	Forehand et al.	8,695,506	B2	4/2014	Lanclos	
4,790,383	A	12/1988	Savage et al.	8,770,301	B2 *	7/2014	Bell	E21B 43/119
4,800,815	A	1/1989	Appledorn et al.					166/378
4,850,438	A	7/1989	Regalbuto	8,863,665	B2	10/2014	DeVries et al.	
4,889,183	A	12/1989	Sommers et al.	8,869,887	B2	10/2014	Deere et al.	
5,027,708	A	7/1991	Gonzalez et al.	8,875,787	B2	11/2014	Tassaroli	
5,042,594	A	8/1991	Gonzalez et al.	8,881,816	B2	11/2014	Glenn et al.	
5,052,489	A	10/1991	Carisella et al.	8,910,718	B2	12/2014	Watson et al.	
5,060,573	A	10/1991	Montgomery et al.	8,985,023	B2	3/2015	Mason	
5,088,413	A	2/1992	Huber	9,080,433	B2	7/2015	Lanclos et al.	
5,159,145	A	10/1992	Carisella et al.	9,145,763	B1	9/2015	Sites, Jr.	
5,159,146	A	10/1992	Carisella et al.	9,145,764	B2	9/2015	Burton et al.	
5,223,665	A	6/1993	Burleson et al.	9,157,718	B2	10/2015	Ross	
5,237,136	A	8/1993	Langston	9,175,553	B2	11/2015	Mccann et al.	
5,241,891	A	9/1993	Hayes et al.	9,181,790	B2	11/2015	Mace et al.	
5,322,019	A	6/1994	Hyland	9,194,219	B1	11/2015	Hardesty et al.	
5,347,929	A	9/1994	Lerche et al.	9,206,675	B2	12/2015	Hales et al.	
5,392,851	A	2/1995	Arend	9,441,465	B2 *	9/2016	Tassaroli	E21B 43/116
5,392,860	A	2/1995	Ross	9,476,289	B2	10/2016	Wells	
5,436,791	A	7/1995	Turano et al.	9,494,021	B2	11/2016	Parks et al.	
5,571,986	A	11/1996	Snider et al.	9,518,443	B2	12/2016	Tunget et al.	
5,703,319	A	12/1997	Fritz et al.	9,518,454	B2	12/2016	Current et al.	
5,775,426	A	7/1998	Snider et al.	9,574,416	B2	2/2017	Wright et al.	
5,816,343	A	10/1998	Markel et al.	9,581,422	B2	2/2017	Preiss et al.	
5,871,052	A	2/1999	Benson et al.	9,598,942	B2	3/2017	Wells et al.	
5,927,402	A	7/1999	Benson et al.	9,605,937	B2	3/2017	Eitschberger et al.	
D417,252	S	11/1999	Kay	9,677,363	B2	6/2017	Schacherer et al.	
6,006,833	A	12/1999	Burleson et al.	9,689,223	B2	6/2017	Schacherer et al.	
6,012,525	A	1/2000	Burleson et al.	9,689,240	B2	6/2017	LaGrange et al.	
6,085,659	A	7/2000	Beukes et al.	9,702,680	B2	7/2017	Parks et al.	
6,112,666	A	9/2000	Murray et al.	9,784,549	B2	10/2017	Eitschberger	
6,263,283	B1	7/2001	Snider et al.	9,810,035	B1	11/2017	Carr et al.	
6,305,287	B1	10/2001	Capers et al.	9,822,618	B2 *	11/2017	Eitschberger	E21B 43/1185
6,333,699	B1	12/2001	Zierolf	9,835,015	B2	12/2017	Hardesty	
6,354,374	B1	3/2002	Edwards et al.	9,874,083	B2	1/2018	Logan et al.	
6,412,388	B1	7/2002	Frazier	10,066,921	B2	9/2018	Eitschberger	
6,418,853	B1	7/2002	Duguet et al.	10,077,641	B2	9/2018	Rogman et al.	
6,439,121	B1	8/2002	Gillingham	10,151,152	B2	12/2018	Wight et al.	
6,497,285	B2	12/2002	Walker	10,151,181	B2	12/2018	Lopez et al.	
6,516,901	B1	2/2003	Falgout	10,174,595	B2	1/2019	Knight et al.	
6,651,747	B2	11/2003	Chen et al.	10,188,990	B2	1/2019	Burmeister et al.	
6,719,061	B2	4/2004	Muller et al.	10,190,398	B2	1/2019	Goodman et al.	
6,739,265	B1	5/2004	Badger et al.	10,273,788	B2	4/2019	Bradley et al.	
6,742,602	B2	6/2004	Protechaud	10,337,270	B2	7/2019	Carisella et al.	
6,752,083	B1	6/2004	Lerche et al.	10,352,136	B2	7/2019	Goyeneche	
7,013,977	B2	3/2006	Nordaas	10,422,195	B2	9/2019	LaGrange et al.	
7,107,908	B2	9/2006	Forman et al.	10,429,161	B2	10/2019	Parks et al.	
				10,458,213	B1	10/2019	Eitschberger et al.	
				10,472,938	B2	11/2019	Parks et al.	
				D873,373	S *	1/2020	Hartman	D22/112
				D892,278	S *	8/2020	Eitschberger	D23/262

(56)

## References Cited

## U.S. PATENT DOCUMENTS

D903,064 S \* 11/2020 Mulhern ..... D23/262  
 D904,475 S 12/2020 Preiss  
 D908,754 S \* 1/2021 Eitschberger ..... D15/139  
 2002/0020320 A1 2/2002 Lebaudy et al.  
 2002/0062991 A1 5/2002 Farrant et al.  
 2003/0000411 A1 1/2003 Cernocky et al.  
 2003/0001753 A1 1/2003 Cernocky et al.  
 2004/0216632 A1 11/2004 Finsterwald  
 2004/0239521 A1 12/2004 Zierolf  
 2005/0194146 A1 9/2005 Barker et al.  
 2005/0229805 A1 10/2005 Myers, Jr. et al.  
 2007/0084336 A1 4/2007 Neves  
 2007/0267195 A1 11/2007 Grigar et al.  
 2008/0047456 A1 2/2008 Li et al.  
 2008/0110632 A1 5/2008 Beall  
 2008/0134922 A1 6/2008 Grattan et al.  
 2008/0173204 A1 7/2008 Anderson et al.  
 2008/0264639 A1 10/2008 Parrott et al.  
 2009/0050322 A1 2/2009 Hill et al.  
 2009/0272529 A1 11/2009 Crawford  
 2009/0301723 A1 12/2009 Gray  
 2010/0000789 A1 1/2010 Barton et al.  
 2010/0024674 A1 2/2010 Peeters et al.  
 2010/0089643 A1 4/2010 Vidal  
 2011/0024116 A1 2/2011 McCann et al.  
 2012/0006217 A1 1/2012 Anderson  
 2012/0152542 A1 6/2012 Le  
 2012/0160483 A1 6/2012 Carisella  
 2012/0199031 A1 8/2012 Lanclos  
 2012/0199352 A1 8/2012 Lanclos et al.  
 2012/0241169 A1 9/2012 Hales et al.  
 2012/0242135 A1 9/2012 Thomson et al.  
 2012/0247769 A1 10/2012 Schacherer et al.  
 2012/0298361 A1 11/2012 Sampson  
 2013/0008639 A1 1/2013 Tassaroli et al.  
 2013/0043074 A1 2/2013 Tassaroli  
 2013/0118342 A1 5/2013 Tassaroli  
 2013/0199843 A1 8/2013 Ross  
 2014/0131035 A1 5/2014 Entchev et al.  
 2015/0136419 A1 5/2015 Mauldin  
 2015/0226044 A1 8/2015 Ursi et al.  
 2016/0040520 A1 2/2016 Tolman et al.  
 2016/0061572 A1 3/2016 Eitschberger et al.  
 2016/0084048 A1 3/2016 Harrigan et al.  
 2016/0108722 A1 4/2016 Whitsitt et al.  
 2016/0168961 A1 6/2016 Parks et al.  
 2016/0202033 A1 7/2016 Shahinpour et al.  
 2016/0273902 A1 9/2016 Eitschberger  
 2016/0290084 A1 10/2016 LaGrange et al.  
 2016/0298404 A1 10/2016 Beckett et al.  
 2016/0356132 A1 12/2016 Burmeister et al.  
 2017/0030693 A1 2/2017 Preiss et al.  
 2017/0052011 A1 2/2017 Parks et al.  
 2017/0138150 A1 5/2017 Yencho  
 2017/0175500 A1 6/2017 Robey et al.  
 2017/0241244 A1 8/2017 Barker  
 2017/0268860 A1 9/2017 Eitschberger  
 2017/0276465 A1 9/2017 Parks et al.  
 2017/0298716 A1 10/2017 McConnell et al.  
 2017/0314373 A9 11/2017 Bradley et al.  
 2018/0080298 A1 3/2018 Covalt et al.  
 2018/0119529 A1 5/2018 Goyeneche  
 2018/0202789 A1 7/2018 Parks et al.  
 2018/0202790 A1 7/2018 Parks et al.  
 2018/0318770 A1 11/2018 Eitschberger et al.  
 2019/0049225 A1 2/2019 Eitschberger  
 2019/0085685 A1 3/2019 McBride  
 2019/0162055 A1 5/2019 Collins et al.  
 2019/0162056 A1 5/2019 Sansing  
 2019/0195054 A1 6/2019 Bradley et al.  
 2019/0211655 A1 7/2019 Bradley et al.  
 2019/0234188 A1 8/2019 Goyeneche  
 2019/0257158 A1 8/2019 Langford et al.  
 2019/0257181 A1 8/2019 Langford et al.  
 2019/0330947 A1 10/2019 Mulhern et al.

2019/0338612 A1 11/2019 Holodnak et al.  
 2019/0368293 A1 12/2019 Covalt et al.  
 2020/0024934 A1 1/2020 Eitschberger et al.  
 2020/0024935 A1 1/2020 Eitschberger et al.  
 2020/0032626 A1 1/2020 Parks et al.  
 2020/0063537 A1 2/2020 Langford et al.  
 2020/0088011 A1 3/2020 Eitschberger et al.  
 2020/0182025 A1 6/2020 Brady  
 2020/0199983 A1 6/2020 Preiss et al.

## FOREIGN PATENT DOCUMENTS

CA 3021913 A1 2/2018  
 CN 85107897 A 9/1986  
 CN 1082601 C 4/2002  
 CN 201209435 3/2009  
 CN 101397890 A 4/2009  
 CN 201428439 3/2010  
 CN 101691837 B 4/2010  
 CN 201507296 U 6/2010  
 CN 201620848 U 11/2010  
 CN 202431259 U 9/2012  
 CN 103485750 A 1/2014  
 CN 103993861 A 8/2014  
 CN 207847603 U 9/2018  
 CN 208347755 U 1/2019  
 CN 208870580 U 5/2019  
 CN 209195374 U 8/2019  
 CN 110424930 A 11/2019  
 CN 209780779 U 12/2019  
 CN 209908471 U 1/2020  
 EP 0416915 A2 3/1991  
 EP 0482969 B1 8/1996  
 GB 2531450 B 2/2017  
 GB 2548101 A 9/2017  
 GB 2548203 A 9/2017  
 RU 100552 U1 12/2010  
 RU 2633904 C1 10/2017  
 WO 2009091422 A2 7/2009  
 WO 2015006869 A1 1/2015  
 WO 2017147329 A1 8/2017  
 WO 2018009223 A1 1/2018  
 WO 2019148009 A2 8/2019

## OTHER PUBLICATIONS

State Intellectual Property Office, P.R. China; First Office Action with full translation for CN App. No. 201480040456.9; dated Mar. 29, 2017; 12 pages (English translation 17 pages).  
 SWM International Inc.; "Thunder Disposable Gun System"; promotional brochure; Oct. 2018; 5 pgs.  
 Thilo Scharf; "DynaEnergetics exhibition and product briefing"; pp. 5-6; presented at 2014 Offshore Technology Conference; May 2014.  
 Thilo Scharf; "DynaStage & BTM Introduction"; pp. 4-5, 9; presented at 2014 Offshore Technology Conference; May 2014.  
 U.S. Patent Trial and Appeal Board, Institution of Inter Partes Review of U.S. Pat. No. 9,581,422, Case IPR2018-00600, Aug. 21, 2018, 9 pages.  
 United States Patent and Trademark Office, Case IPR2018-00600 for U.S. Pat. No. 9,581,422 B2, DynaEnergetics GmbH & Co. KG's Patent Owner Preliminary Response, dated May 22, 2018, 47 pgs.  
 United States Patent and Trademark Office, Case IPR2018-00600 for U.S. Pat. No. 9,581,422 B2, Patent Owner's Motion to Amend, dated Dec. 6, 2018, 53 pgs.  
 United States Patent and Trademark Office, Case IPR2018-00600 for U.S. Pat. No. 9,581,422 B2, Petitioner's Reply in Inter Partes Review of U.S. Pat. No. 9,581,422, dated Mar. 7, 2019, 44 pgs.  
 United States Patent and Trademark Office, Final Written Decision of Case IPR2018-00600 for U.S. Pat. No. 9,581,422 B2, Paper No. 42, dated Aug. 20, 2019, 31 pgs.  
 United States Patent and Trademark Office, Non-final Office Action of U.S. Appl. No. 16/455,816, dated Jul. 2, 2020, 15 pgs.  
 United States Patent and Trademark Office, Office Action of U.S. Appl. No. 16/585,790, dated Nov. 12, 2019, 9 pgs.

(56) **References Cited**

## OTHER PUBLICATIONS

- United States Patent and Trademark Office, Office Action of U.S. Appl. No. 16/858,041, dated Jun. 16, 2020, 11 pgs.
- United States Patent and Trademark Office, Office Action of U.S. Appl. No. 29/733,080, dated Jun. 26, 2020, 8 pgs.
- United States Patent and Trademark Office, Office Action of U.S. Appl. No. 29/733,325, dated Jun. 26, 2020, 9 pgs.
- United States Patent and Trademark Office, Restriction Requirement for U.S. Appl. No. 16/258,810, dated Aug. 20, 2020, 8 pgs.
- United States Patent and Trademark Office, U.S. Appl. No. 61/733,129, filed Dec. 4, 2012; 10 pages.
- United States Patent and Trademark Office, U.S. Appl. No. 61/819,196, filed May 3, 2013; 10 pages.
- United States Patent and Trademark Office; Notice of Allowance for U.S. Appl. No. 29/733,325; dated Oct. 23, 2020; 7 pages.
- Vigor USA; "Sniper Addressable System"; promotional brochure; Sep. 2019.
- Vigor, Perforating Gun Accessories, China Vigor Drilling Oil Tools And Equipment Co., Ltd., Sep. 14, 2018, 4 pgs., <http://www.vigordrilling.com/completion-tools/perforating-gun-accessories.html>.
- Yellow Jacket Oil Tools, Orienting Sub, 2019, 2 pgs., <https://www.yjoiltools.com/Wireline-Subs/Orienting-Sub>.
- Yellow Jacket Oil Tools; Tandem Sub; 2019; 3 pages.
- Amit Govil, Selective Perforation: A Game Changer in Perforating Technology—Case Study, presented at the 2012 European and West African Perforating Symposium, Schlumberger, Nov. 7-9, 2012, 14 pgs.
- Austin Powder Company; A—140 F & Block, Detonator & Block Assembly; Jan. 5, 2017; 2 pgs.; [https://www.austinpowder.com/wp-content/uploads/2019/01/OilStar\\_A140Fbk-2.pdf](https://www.austinpowder.com/wp-content/uploads/2019/01/OilStar_A140Fbk-2.pdf).
- Baker Hughes, Long Gun Deployment Systems IPS-12-28; 2012 International Perforating Symposium; Apr. 26-27, 2011; 11 pages.
- Core Lab, Zero180™ Gun System Assembly and Arming Procedures, 2015, 33 pgs., <https://www.corelab.com/owen/CMS/docs/Manuals/gunsys/zero180/MAN-Z180-000.pdf>.
- Dynaenergetics GmbH & Co. KG, Patent Owner's Response to Hunting Titan's Petition for Inter Parties Review—Case IPR2018-00600, filed Dec. 6, 2018, 73 pages.
- Dynaenergetics, DYNAselct Electronic Detonator 0015 SFDE RDX 1.4B, Product Information, Dec. 16, 2011, 1 pg.
- Dynaenergetics, DYNAselct Electronic Detonator 0015 SFDE RDX 1.4S, Product Information, Dec. 16, 2011, 1 pg.
- Dynaenergetics, DYNAselct System, information downloaded from website, Jul. 3, 2013, 2 pages, <http://www.dynaenergetics.com/>.
- Dynaenergetics, Gun Assembly, Product Summary Sheet, May 7, 2004, 1 page.
- Dynaenergetics, Selective Perforating Switch, information downloaded from website, Jul. 3, 2013, 2 pages, <http://www.dynaenergetics.com/>.
- Dynaenergetics, Selective Perforating Switch, Product Information Sheet, May 27, 2011, 1 pg.
- Dynaenergetics; DynaStage Solution—Factory Assembled Performance-Assured Perforating Systems; 6 pages.
- Eric H. Findlay, Jury Trial Demand in Civil Action No. 6:20-cv-00069-ADA, dated Apr. 22, 2020, 32 pages.
- GB Intellectual Property Office, Examination Report for GB App. No. GB1600085.3, dated Mar. 9, 2016, 1 pg.
- GB Intellectual Property Office, Search Report for App. No. GB1700625.5; dated Jul. 7, 2017; 5 pgs.
- GB Intellectual Property Office; Office Action for GB App. No. 1717516.7; dated Feb. 27, 2018; 6 pages.
- GE Oil & Gas, Pipe Recovery Technology & Wireline Accessories, 2013, 435 pages.
- GeoDynamics; "STRATX"; promotional brochure; Jan. 30, 2020.
- GeoDynamics; "VaporGun"; promotional brochure; Mar. 4, 2020.
- GeoDynamics; "Vap"; promotional brochure; Oct. 1, 2019.
- German Patent Office, Office Action for German Patent Application No. 10 2013 109 227.6, which is in the same family as PCT Application No. PCT/EP2014/065752, May 22, 2014, 8 pgs.
- Gilliat et al.; New Select-Fire System: Improved Reliability and Safety in Select Fire Operations; 2012; 16 pgs.
- Horizontal Wireline Services, Presentation of a completion method of shale demonstrated through an example of Marcellus Shale, Pennsylvania, USA, Presented at 2012 International Perforating Symposium (Apr. 26-28, 2012), 17 pages.
- Hunting Energy Service, ControlFire RF Safe ControlFire® RF—Safe Manual, 33 pgs., Jul. 2016, [http://www.hunting-intl.com/media/2667160/ControlFire%20RF\\_Assembly%20Gun%20Loading\\_Manual.pdf](http://www.hunting-intl.com/media/2667160/ControlFire%20RF_Assembly%20Gun%20Loading_Manual.pdf).
- Hunting Energy Services Pte Ltd., "H-1 Perforating Gun System"; promotional brochure; Jun. 21, 2019.
- Hunting Energy Services Pte Ltd., "H-2 Perforating System"; promotional brochure; Feb. 12, 2020.
- Hunting Titan Inc.; Petition for Post Grant Review of U.S. Pat. No. 10,429,161; dated Jun. 30, 2020; 109 pages.
- Hunting Titan Ltd.; Petition for Inter Parties Review of U.S. Pat. No. 9,581,422 Case No. IPR2018-00600; dated Feb. 16, 2018; 93 pages.
- Hunting Titan, H-1® Perforating Gun System, 2016, 2 pgs., <http://www.hunting-intl.com/titan>.
- Hunting Titan, Wireline Top Fire Detonator Systems, Nov. 24, 2014, 2 pgs, <http://www.hunting-intl.com/titan/perforating-guns-and-setting-tools/wireline-top-fire-detonator-systems>.
- Intellectual Property India, Office Action of IN Application No. 201647004496, dated Jun. 7, 2019, 6 pgs.
- International Searching Authority; International Search Report and Written Opinion for PCT App. No. PCT/CA2014/050673; dated Oct. 9, 2014; 7 pages.
- International Searching Authority; International Search Report and Written Opinion for PCT App. No. PCT/EP20191072064; dated Nov. 20, 2019; 15 pages.
- International Searching Authority; International Search Report and Written Opinion for PCT App. No. PCT/US2015/018906; dated Jul. 10, 2015; 12 pages.
- Jet Research Center Inc., JRC Catalog, 2008, 36 pgs., [https://www.jetresearch.com/content/dam/jrc/Documents/Books\\_Catalogs/06\\_Dets.pdf](https://www.jetresearch.com/content/dam/jrc/Documents/Books_Catalogs/06_Dets.pdf).
- Jet Research Center Inc., Red RF Safe Detonators Brochure, 2008, 2 pages, [www.jetresearch.com](http://www.jetresearch.com).
- Jet Research Center, Plugs and Setting Tools, Alvarado, Texas, 13 pgs., [https://www.jetresearch.com/content/dam/jrc/Documents/Books\\_Catalogs/02\\_Plugs\\_STNG\\_Tool.pdf](https://www.jetresearch.com/content/dam/jrc/Documents/Books_Catalogs/02_Plugs_STNG_Tool.pdf).
- Jet Research Center, Velocity™ Perforating System Plug and Play Guns For Pumpdown Operation, Ivarado, Texas, Jul. 2019, 8 pgs., <https://www.jetresearch.com/content/dam/jrc/Documents/Brochures/jrc-velocity-perforating-system.pdf>.
- Norwegian Industrial Property Office; Office Action and Search Report for NO App. 20160017; dated Jun. 15, 2017; 5 pages.
- Norwegian Industrial Property Office; Office Action and Search Report for NO App. No. 20171759; dated Jan 14, 2020; 6 pages.
- Oso Perforating; "OsoLite"; promotional brochure; Jan. 2019.
- Owen Oil Tools, E & B Select Fire Side Port, Tandem Sub, Apr. 2010, 2 pgs., [https://www.corelab.com/owen/cms/docs/Canada/10A\\_eandbssystem-01.0-c.pdf](https://www.corelab.com/owen/cms/docs/Canada/10A_eandbssystem-01.0-c.pdf).
- Owen Oil Tools, Expendable Perforating Guns, Jul. 2008, 7 pgs., [https://www.corelab.com/owen/cms/docs/Canada/10A\\_erhsc-01.0-c.pdf](https://www.corelab.com/owen/cms/docs/Canada/10A_erhsc-01.0-c.pdf).
- Owen Oil Tools, Recommended Practice for Oilfield Explosive Safety, Presented at 2011 MENAPS Middle East and North Africa Perforating Symposium, Nov. 28-30, 2011, 6 pages.
- Owens Oil Tools, E & B Select Fire Side Port Tandem Sub Assembly, 2009, 9 pgs., <https://www.corelab.com/owen/CMS/docs/Manuals/gunsys/MAN-30-XXX-0002-96-R00.pdf>.
- Robert Parrott, Case IPR2018-00600 for U.S. Pat. No. 9,581,422 B2, Declaration regarding Patent Invalidity, dated Jun. 29, 2020, 146 pages.
- Schlumberger & Said Abubakr, Combining and Customizing Technologies for Perforating Horizontal Wells in Algeria, Presented at 2011 MENAPS, Nov. 28-30, 2011, 20 pages.
- Schlumberger, Perforating Services Catalog, 2008, 521 pages.
- SIPO, Search Report dated Mar. 29, 2017, in Chinese: See Search Report for CN App. No. 201480040456.9, 12 pgs. (English Translation 3 pgs.).

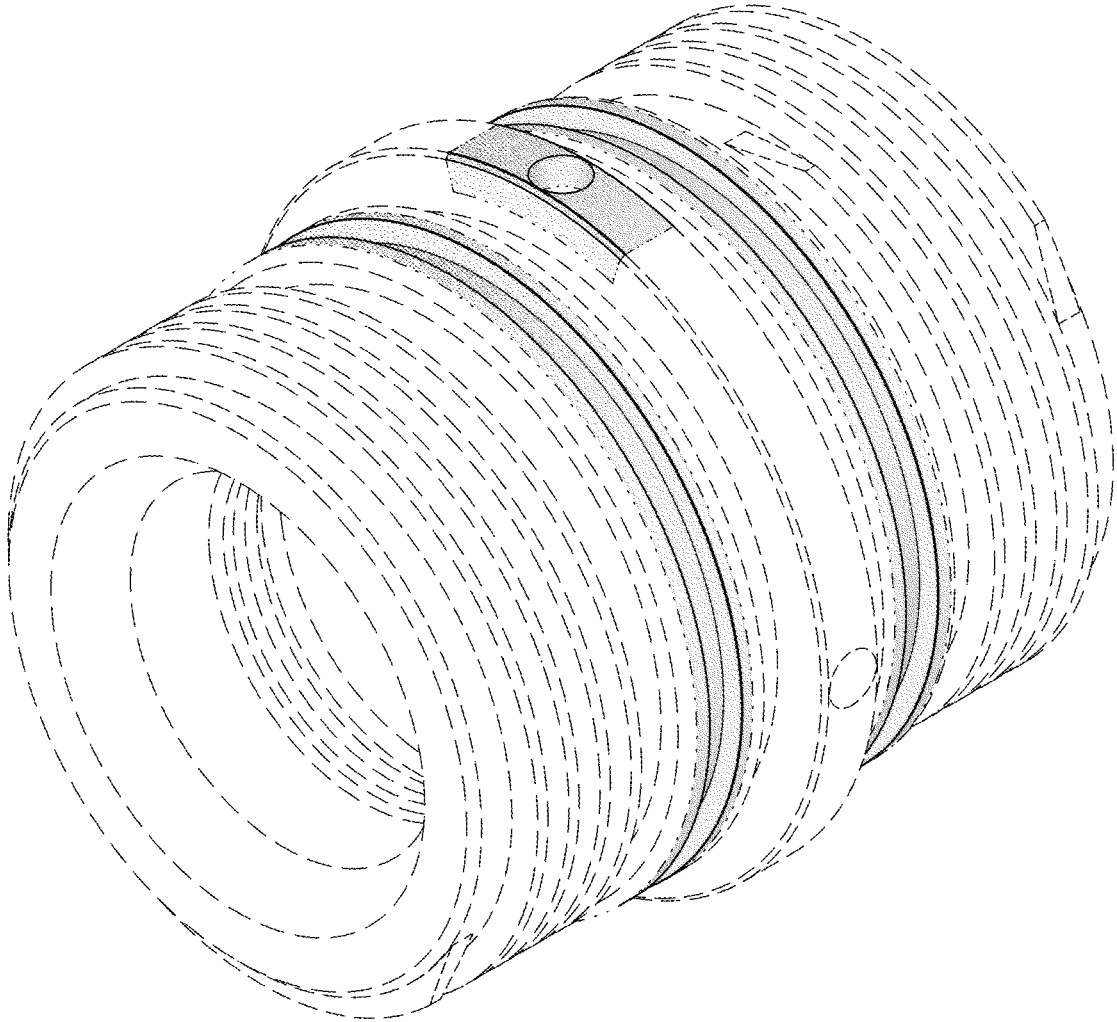
(56)

**References Cited**

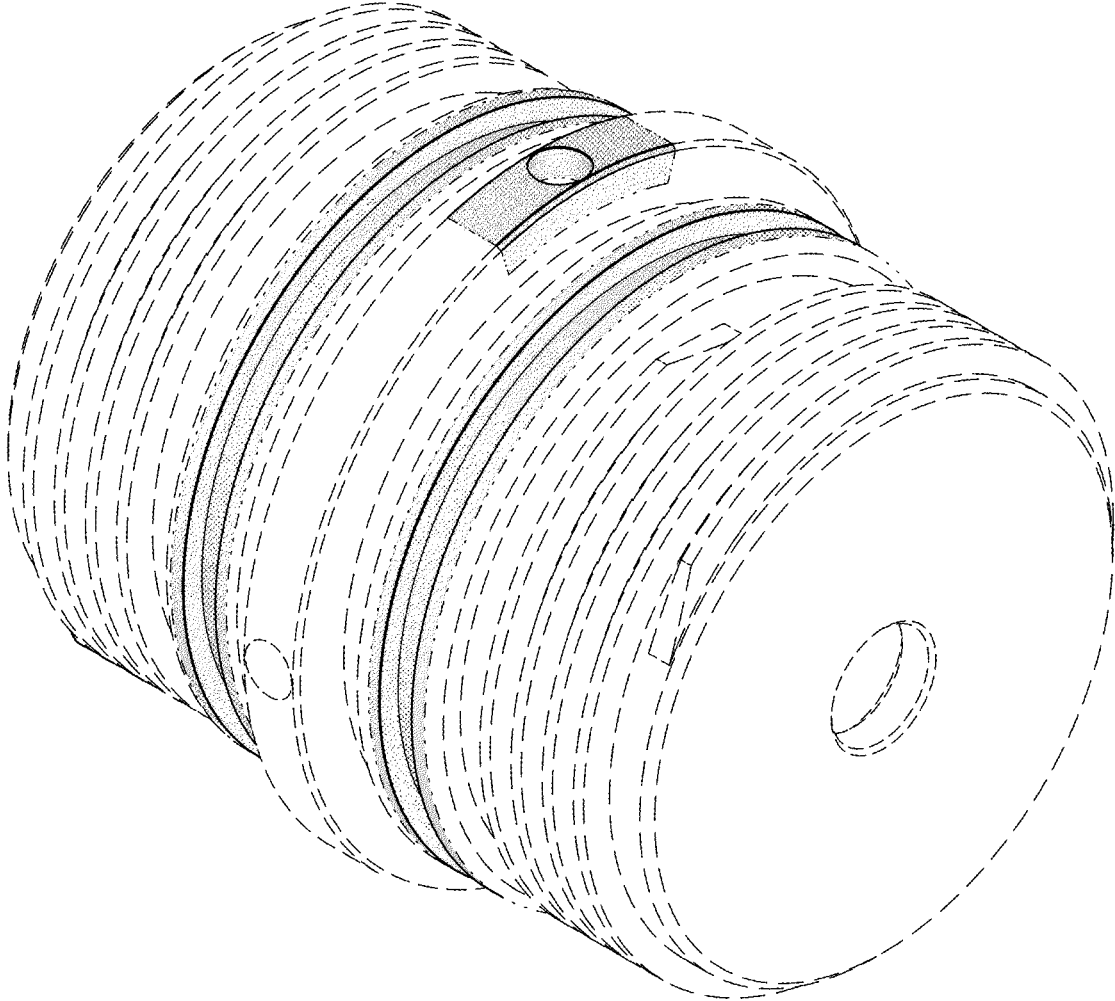
OTHER PUBLICATIONS

Smylie, Tom, New Safe and Secure Detonators for the Industry's consideration, presented at Explosives Safety & Security Conference, Marathon Oil Co, Houston; Feb. 23-24, 2005, 20 pages.

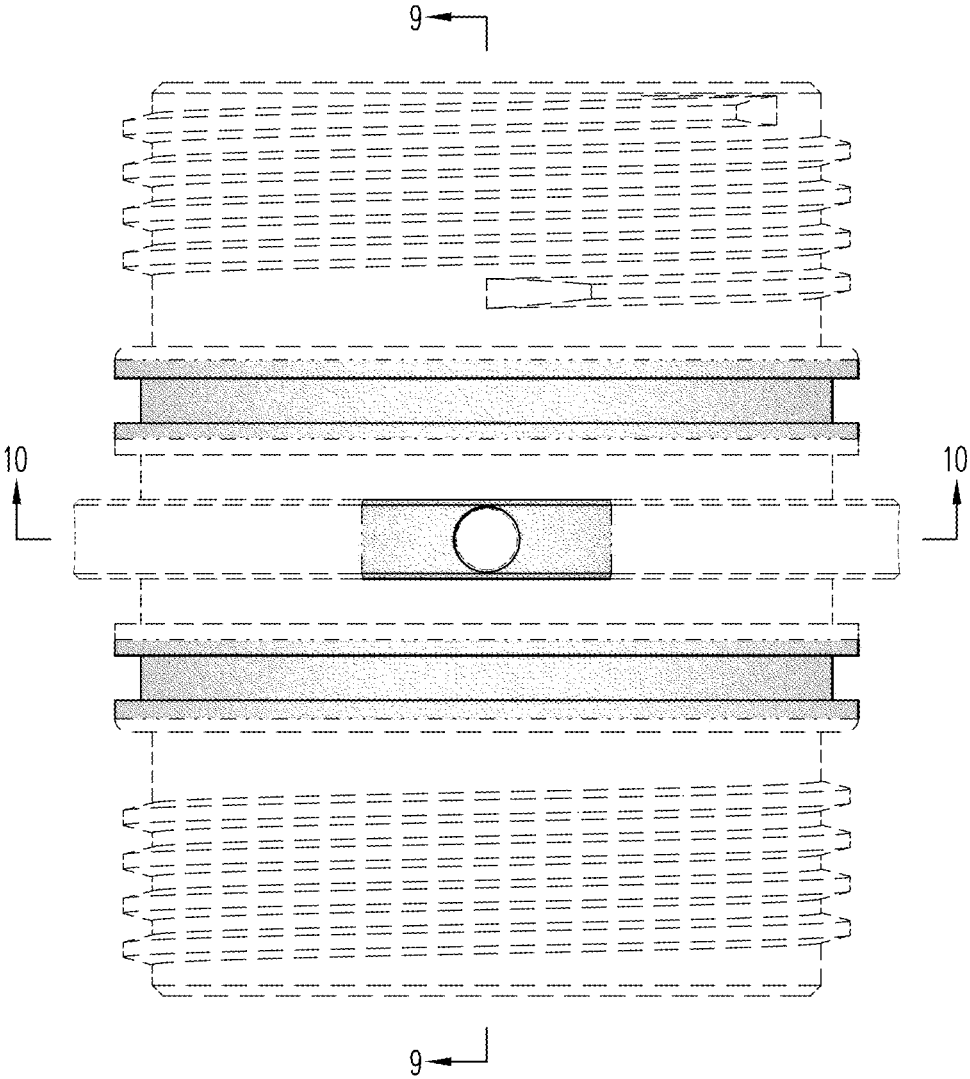
\* cited by examiner



**FIG. 1**

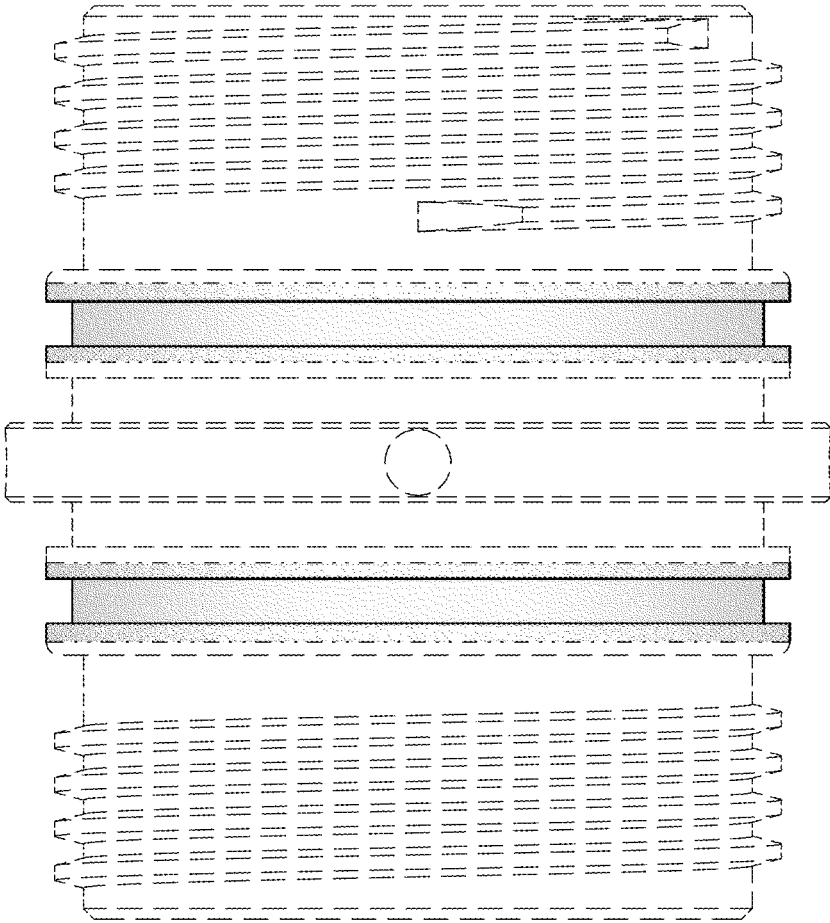


**FIG. 2**

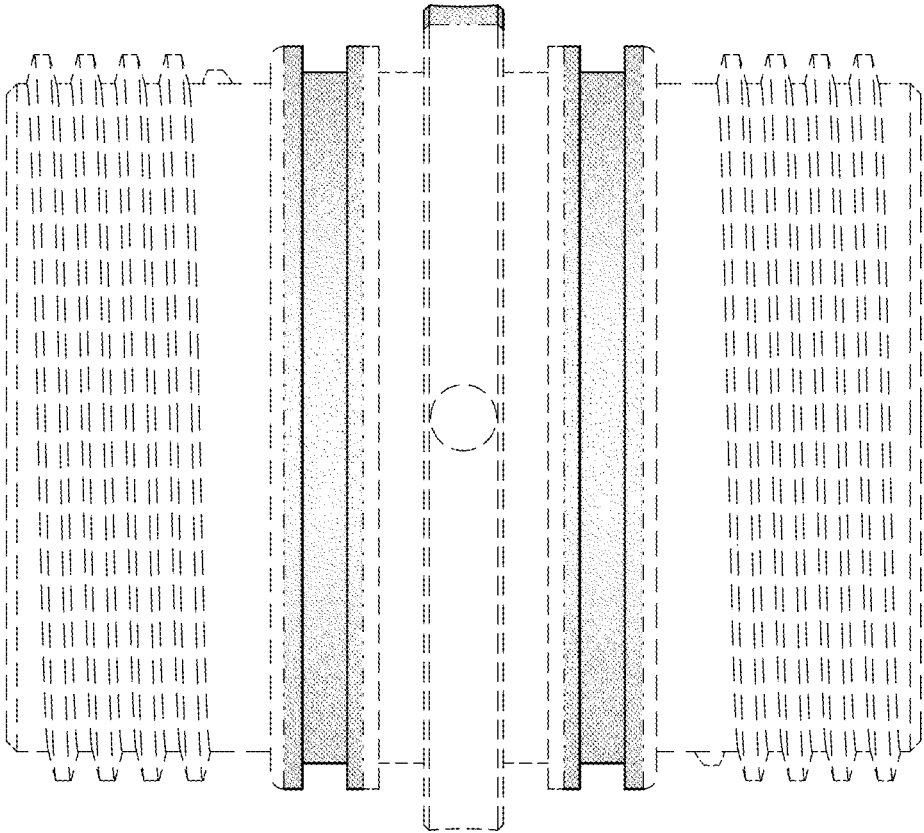


**FIG. 3**

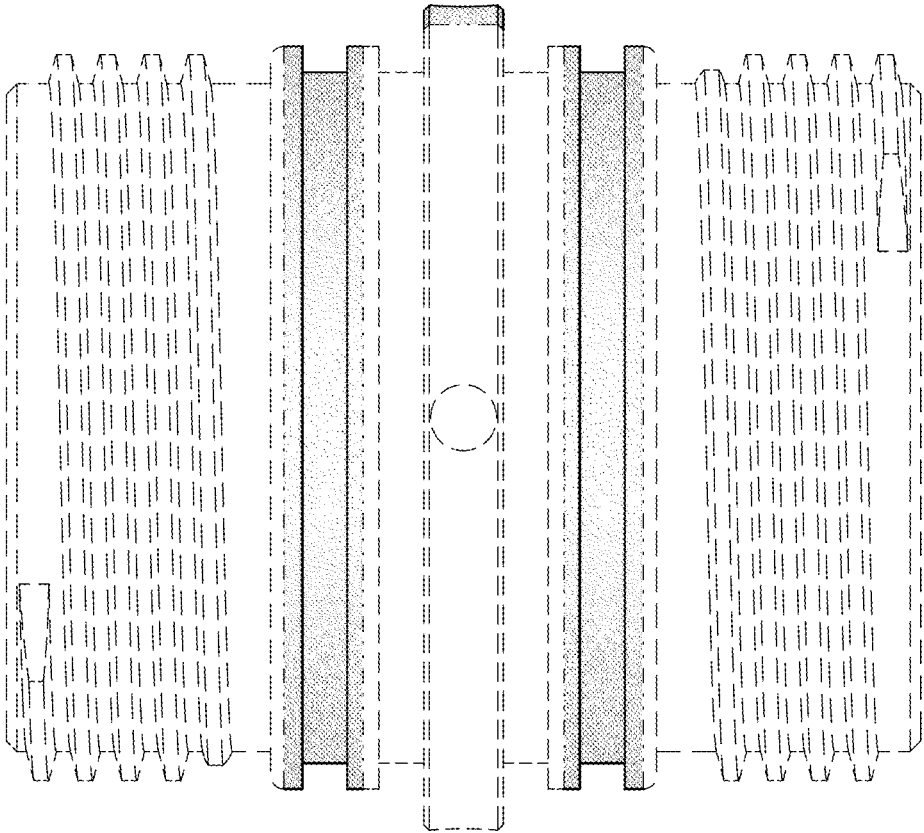




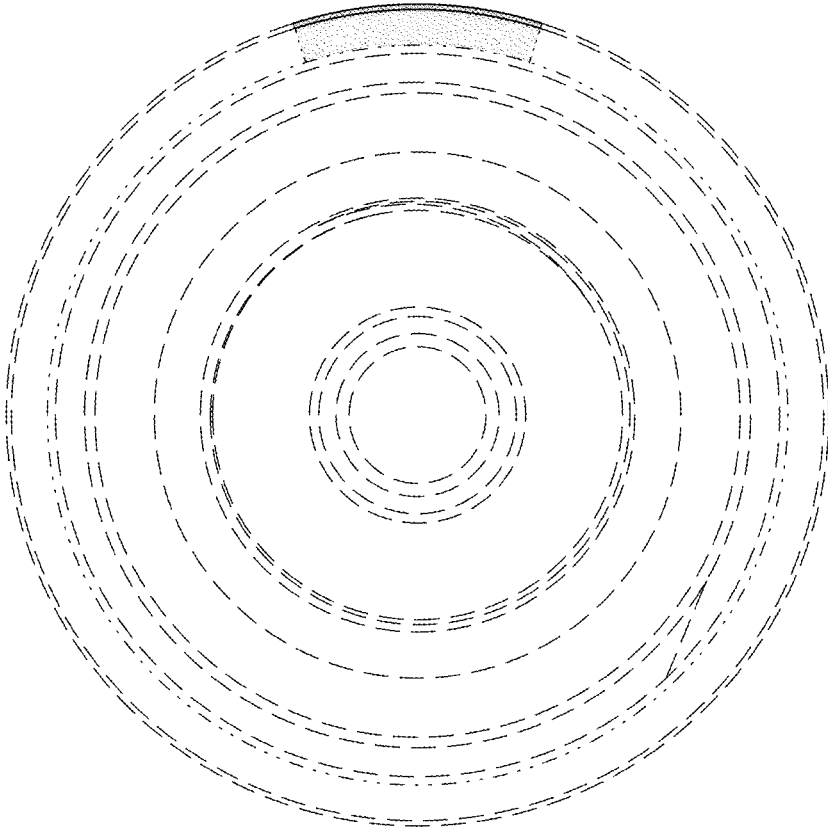
**FIG. 4**



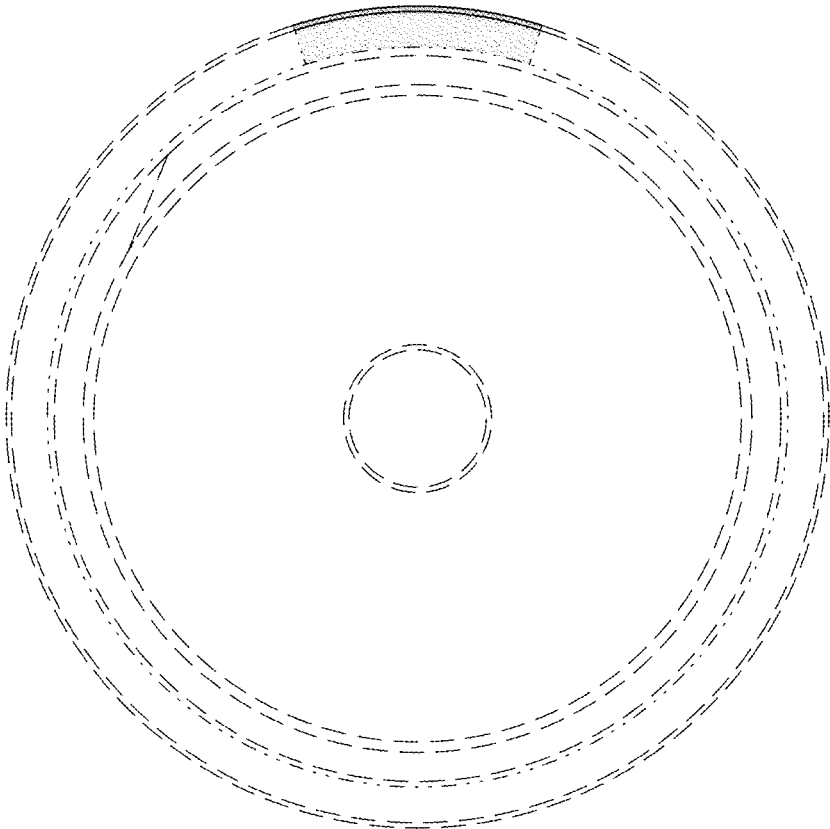
**FIG. 5**



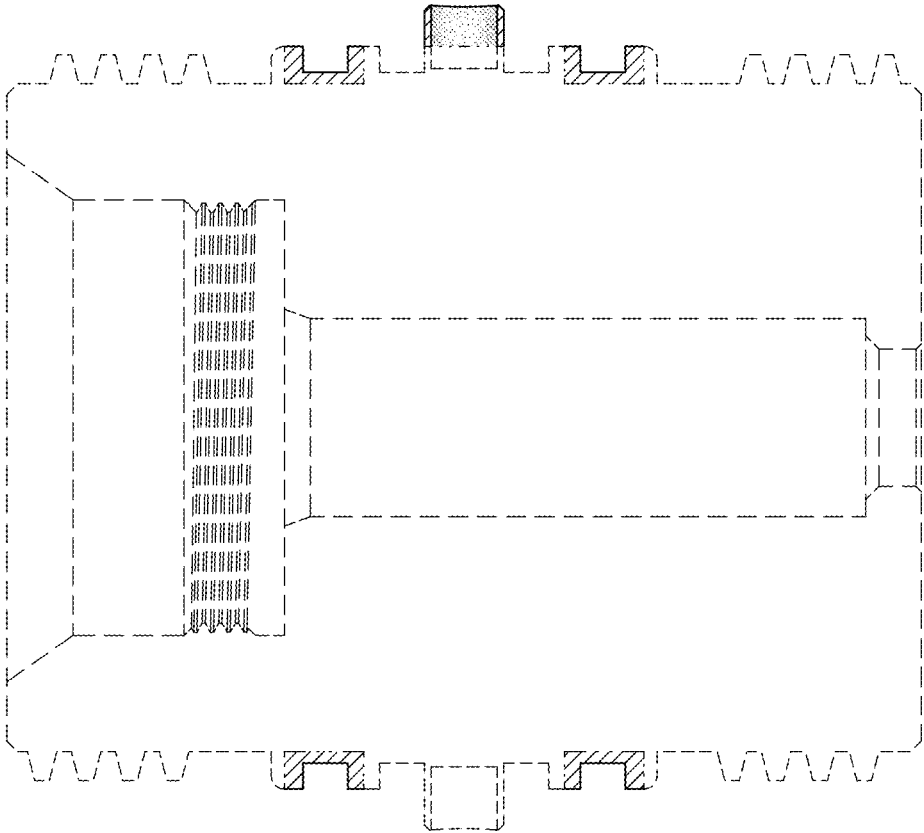
**FIG. 6**



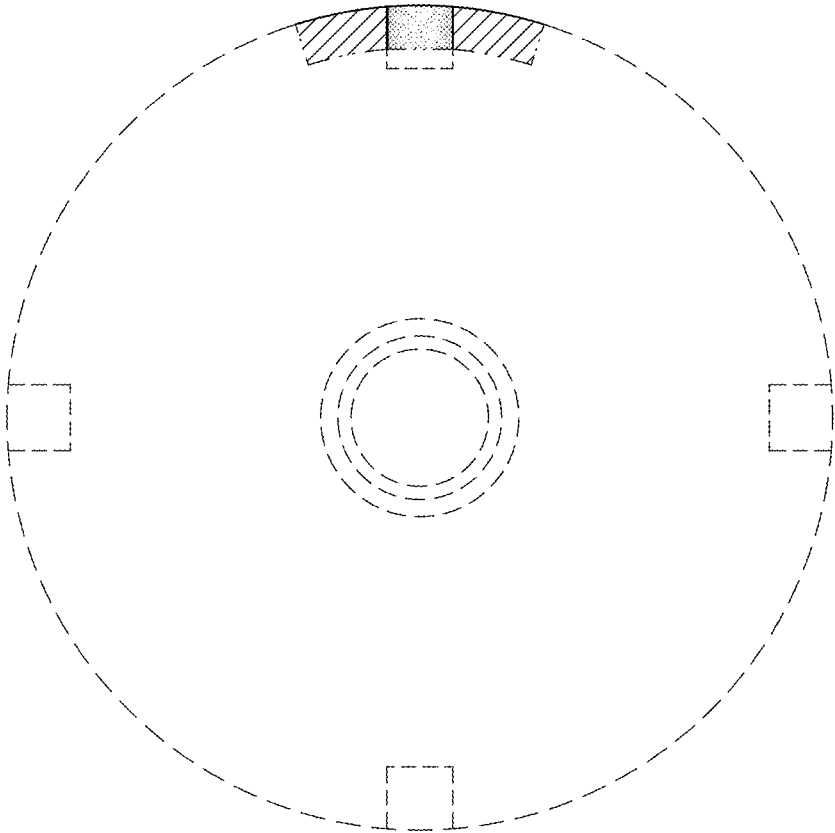
**FIG. 7**



**FIG. 8**



**FIG. 9**



**FIG. 10**